

EM converterLED ONC 250V 3h

BASIC series

Product description

- Self contained emergency lighting LED driver for manual testing
- For LED modules with a forward voltage of 50 – 250 V
- Low profile casing (21 x 30 mm cross-section)
- For luminaire installation
- Nominal lifetime up to 50,000 h
- 4 years guarantee (Conditions at www.tridonic.com)

Properties

- Non maintained operation
- 3 h rated duration
- 3-pole technology: 2-pole LED module changeover and delayed power switching for the LED driver
- Automatic shutdown of output if LED load is out of range
- Constant power output
- Maximum light output for all LED modules
- Electronic charge system
- Deep discharge protection
- Short-circuit-proof battery connection
- Polarity reversal protection for battery provided by 3-pole connector

Batteries

- High-temperature cells
- LiFePO₄ batteries
- 26650 cell
- 4 – 8 years design life for LiFePO₄ batteries
- 4 years guarantee for LiFePO₄ batteries



Standards, page 5

Wiring diagrams and installation examples, page 6



EM converterLED ONC 250V 3h BASIC series

Technical data

Rated supply voltage	220 – 240 V
AC voltage range	198 – 264 V
Mains frequency	50 / 60 Hz
LED module forward voltage range	50 – 250 V
Output current	see chapter 5.3
Starting time	< 0.5 s from detection of emergency event
Overvoltage protection	320 V (for 48 h)
U-OUT (including open- / short-circuit and double load)	280 V
Max. open circuit voltage	280 V
Battery charging time [®]	24 h
Ambient temperature range t_a	-5 ... + 55 °C
Max. casing temperature t_c	75 °C
Mains voltage changeover threshold	according to EN 60598-2-22
Mains surge capability (between L – N)	1 kV
Mains surge capability (between L/N – PE)	2 kV
Type of protection	IP20
Lifetime	up to 50,000 h
Guarantee (conditions at www.tridonic.com)	4 years
Dimensions LxWxH	179 x 30 x 21 mm

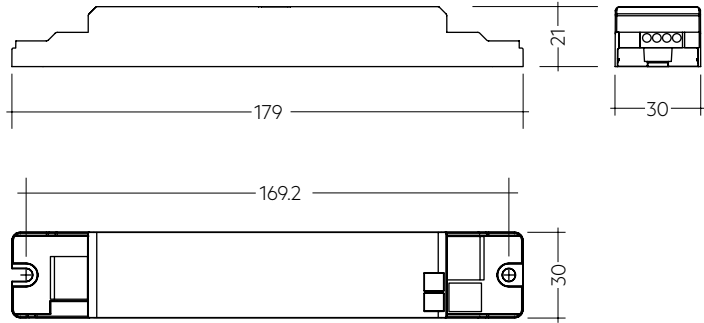

Ordering data

Type [®]	Article number	Rated duration	Packaging, carton	Packaging, pallet	Weight per pc.
EMcLED ONC 232 LiFePO4 250V	89801161	3 h	10 pc(s).	1,600 pc(s).	0.07 kg

Specific technical data

Type [®]	Battery technology	Rated duration	Typ. λ (at 230 V, 50 Hz)	Typ. output power P emergency	Mains current in charging operation			Rated power in charging operation		
					Initial charge	Fast recharge	Trickle charge	Initial charge	Fast recharge	Trickle charge
EMcLED ONC 232 LiFePO4 250V	LiFePO ₄	3 h	0.60C	1.8 W	20 mA	20 mA	20 / 12 mA	2.9 W	2.9 W	2.9 / 1.4 W

[®] EM = Emergency.

[®] 12 h battery charging time for 2 h emergency lighting function when used with LiFePO₄ batteries.



ACCES-
SORIES

EMcLED Strain-relief set 240x43x30mm

Product description

- Optional strain-relief set for independent applications
- Transforms the LED driver into a fully class II compatible LED driver (e.g. ceiling installation)
- Easy and tool-free mounting to the LED driver, screwless cable-clamp channels with strain-relief (240 x 43 x 30 mm)

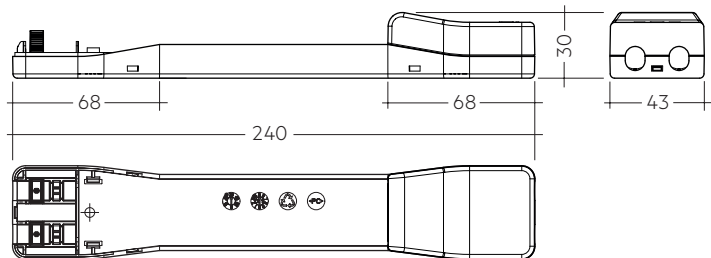
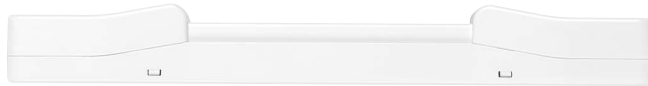
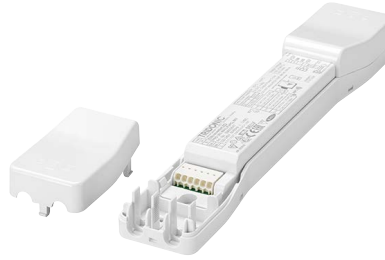

Permissible cable jacket diameter 2.2 – 9 mm

Ordering data

Type	Article number	Packaging, carton	Packaging, pallet	Weight per pc.
EMcLED SR	28003813	10 pc(s).	1,260 pc(s).	0.08 kg

Status indication green LED

Product description

- A green LED indicates that charging current is flowing into the battery
- Plug connection



Ordering data

Type	Article number	Packaging, bag	Packaging, carton	Weight per pc.
LED EM green, 1.0 m CON	89800269	25 pc(s).	200 pc(s).	0.015 kg
LED EM green, HO 1.0 m CON	89800271	25 pc(s).	200 pc(s).	0.015 kg
LED EM green, 0.6 m CON	89800472	25 pc(s).	200 pc(s).	0.009 kg
LED EM green, HO 0.6 m CON	89800473	25 pc(s).	200 pc(s).	0.009 kg
LED EM green, 0.3 m CON	89800270	25 pc(s).	200 pc(s).	0.005 kg
LED EM green, HO 0.3 m CON	89800272	25 pc(s).	200 pc(s).	0.005 kg

Extension Cable LiFePO4

Product description

- Extension cable for LiFePO₄ batteries
- Cable length 500 mm
- 3-pole plug connection



Ordering data

Type	Article number	Packaging, bag	Packaging, carton	Weight per pc.
EXTENSION CABLE LiFePO4 500mm	28002461	10 pc(s).	200 pc(s).	0.01 kg

1. Standards

- EN 61347-1
- EN 61347-2-13
- EN 61347-2-7
- EN 55015
- EN 61000-3-2
- EN 61000-3-3
- EN 61547
- EN 60068-2-64
- EN 60068-2-29
- EN 60068-2-30
- EN 62384
- according to EN 50172
- according to EN 60598-2-22

Meaning of marking 

Double or reinforced insulation for built-in electronic LED drivers. The control gear relies upon the luminaire enclosure for protection against accidental contact with live parts.

1.1 Glow-wire test

according to EN 61347-1 with increased temperature of 850 °C passed.

1.2 Insulation and electric strength testing of luminaires

Electronic LED-drivers can be damaged by high voltage. This has to be considered during the routine testing of the luminaires in production.

According to IEC 60598-1 Annex Q (informative only!) or ENEC 303-Annex A, each luminaire should be submitted to an insulation test with 500 V_{dc} for 1 second. This test voltage should be connected between the interconnected phase and neutral terminals and the earth terminal. The insulation resistance must be at least 2 MΩ.

As an alternative, IEC 60598-1 Annex Q describes a test of the electrical strength with 1,500 V_{AC} (or 1,414 x 1,500 V_{DC}). To avoid damage to the electronic devices this test **must not be conducted**.

2. Thermal details and lifetime

2.1 Lifetime

Average lifetime 50,000 hours under rated conditions with a failure rate of less than 10 %. Average failure rate of 0.2 % per 1000 operating hours.

Expected lifetime with LiFePO₄ batterie

	t _c	65 °C	70 °C	75 °C
EMcLED ONC 232 LiFePO₄ 250V	lifetime	> 50,000 h	> 50,000 h	> 50,000 h

The emergency lighting LED driver is designed for a lifetime stated above under reference conditions and with a failure probability of less than 10 %.

The relation of t_c to t_a temperature depends also on the luminaire design. If the measured t_c temperature is approx. 5 K below t_c max., t_a temperature should be checked and eventually critical components (e.g. ELCAP) measured. Detailed information on request.

3. Installation / Wiring

3.1 Wiring diagram

One or more LED modules with a total forward voltage of 50 to 250 V can be connected to the EM converterLED 250V module.

These LED module(s), marked with "Emergency" are operated in emergency mode from the associated battery. In normal mains mode all LED modules are operated by the LED driver from the mains supply.

EM converterLED BASIC with one LED module for non-maintained emergency operation

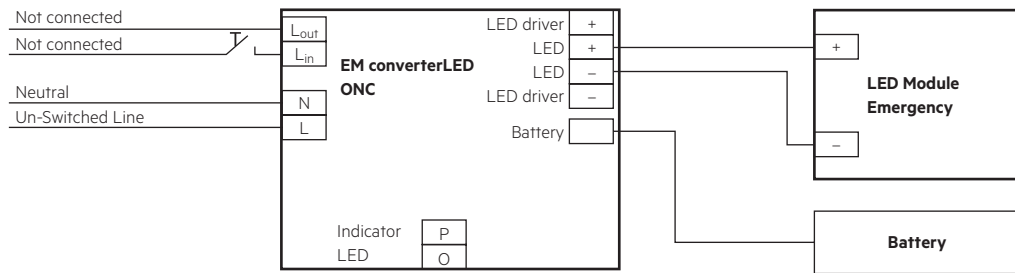

EM converterLED BASIC with a standard LED driver and one LED module for mains and emergency operation

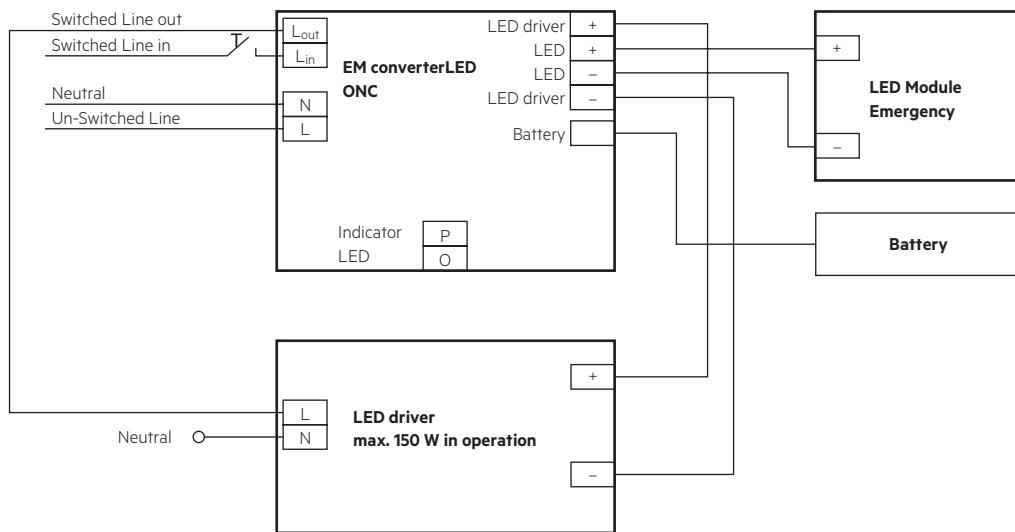

EM converterLED BASIC with a standard LED driver and series operation of LED modules

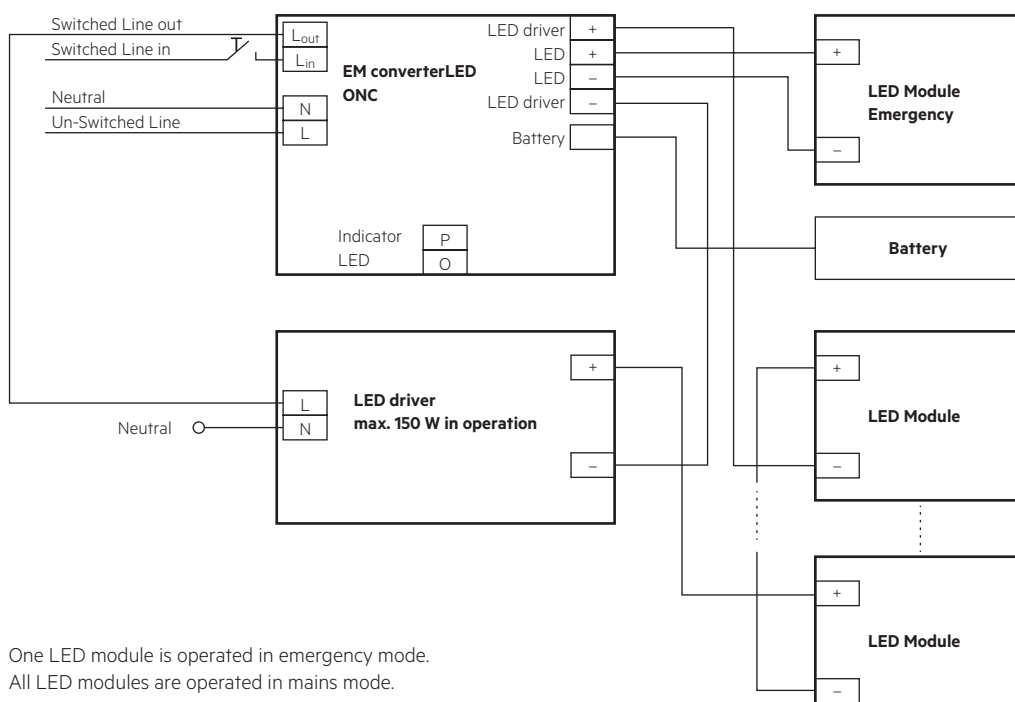

One LED module is operated in emergency mode.
All LED modules are operated in mains mode.

EM converterLED BASIC with a standard LED driver and parallel operation of LED modules

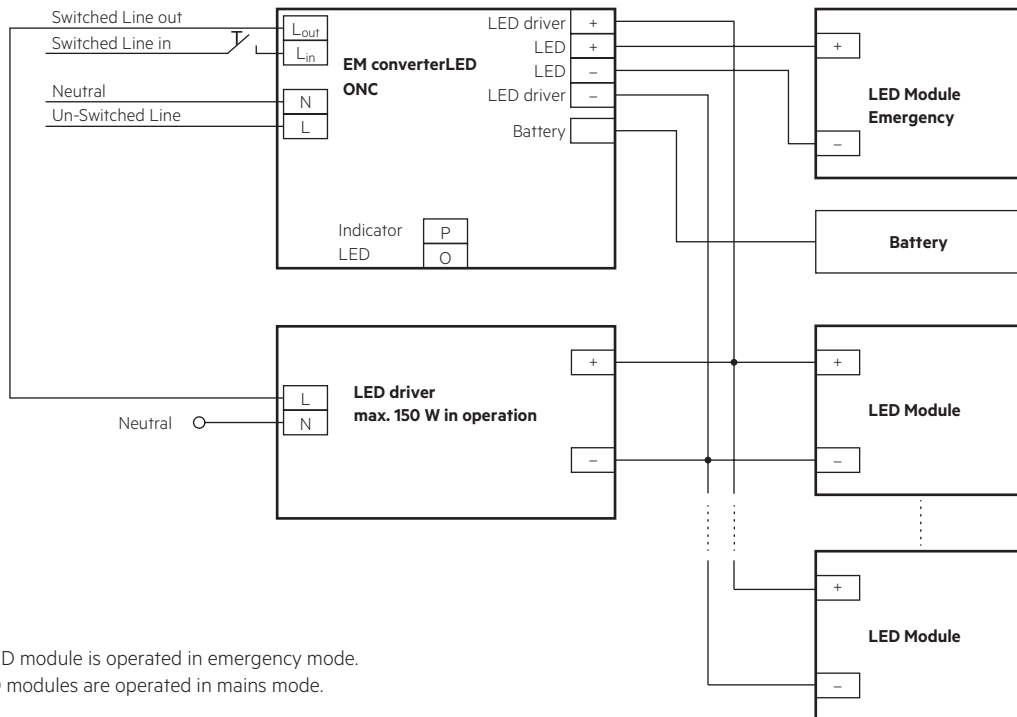

One LED module is operated in emergency mode.
All LED modules are operated in mains mode.

3.2 Wiring type and cross section

Solid wire with a cross section of 0.5 – 1.5 mm². Strip 8 – 9 mm of insulation from the cables to ensure perfect operation of terminals.

Wiring: LED module/LED driver/supply

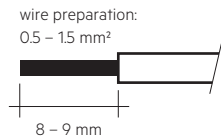

3.3 Battery connection

LiFePO₄: Direct connection

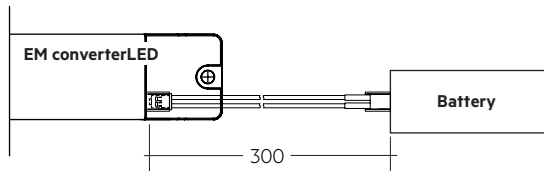

LiFePO₄: Connection with extension

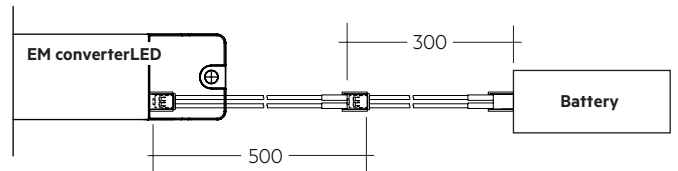

3.4 Loose wiring

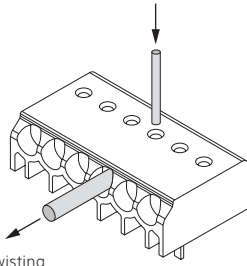

Loosen wire through twisting and pulling or using a \varnothing 1 mm release tool

3.5 Wiring guidelines

- The output to the LED is DC but has high frequency content, which should be considered for good EMC compliance.
- Separate LED leads from the mains and DALI connections and wiring for good EMC performance.
- Maximum lead length on the LED terminals is 3 m. For a good EMC performance keep the LED wiring as short as possible.
- Route the secondary wires (LED module) in parallel to ensure good EMC performance.
- Maximum lead length for the Indicator LED connection is 1 m. Separate the Indicator LED wiring from the LED leads to prevent noise coupling.
- Battery leads are specified with 0.5 mm cross section and a length of 0.8 m
- Protect the wiring against short circuits to earth (sharp edged metal parts, metal cable clips, louver, etc.) to avoid the damage of the control gear.

To ensure that a luminaire containing LED emergency units complies with EN 55015 for radio frequency conducted interference in both normal and emergency mode it is essential to follow good practice in the wiring layout.

Within the luminaire route the switched and unswitched 50 Hz supply wiring as short as possible and keep it as far away as possible from the LED leads. Through wiring may affect the EMC performance of the luminaire.

Do not exceed the max. length of LED leads to the LED module. Note that the length of the EM converterLED leads to the LED module is added to the length of the leads from the LED driver to the EM converterLED module when considering the max. permitted lead length of the LED driver.

3.6 Maximum lead length

LED	3 m (6 m loop) ^①
Status indication LED	1 m
Batteries	0.8 m

^① Note: The length of LED leads to the LED module must not be exceeded. Note that the length of the EM converterLED leads is added to the length of the leads from the LED driver to the EM converterLED module when considering max. permitted lead length of the LED driver. Leads should always be kept as short as possible.

3.7 Use of different phases

The use of different phases for switched line and unswitched line is allowed. When using different phases, the unswitched line must fail if the switched line fails. This is required to assure correct switching into emergency mode. It can be realised with a relay.

4. Mechanical values

4.1 Housing properties

- Casing manufactured from polycarbonate.
- Type of protection: IP20
- Max. torque at the mounting screws: 0.8 Nm

4.2 Mechanical data accessories

LED status indicator

- Green
- Mounting hole 6.5 mm diameter, 1 – 1.6 mm thickness
- Lead length 0.3 m / 0.6 m / 1.0 m
- Insulation rating: 90 °C
- Plug connection

Battery connection

- Plug connection 0.3 m
- Extension 0.5 m

5. Electrical values

5.1 Maximum loading of automatic circuit breakers

Automatic circuit breaker type	B10	B13	B16	B20	C10	C13	C16	C20	Inrush current	
Installation \emptyset	1.5 mm ²	1.5 mm ²	1.5 mm ²	2.5 mm ²	1.5 mm ²	1.5 mm ²	1.5 mm ²	2.5 mm ²	I_{max}	time
EMcLED ONC 232 LiFePO₄ 250V	90	130	130	130	180	260	260	260	10 A	120 μ s

5.2 Insulation matrix

	Mains	Switched Live	Battery, LED, Indicator LED	LED driver
Mains	-	•	••	••
Switched Live	•	-	••	••
Battery, LED, Indicator LED	••	••	-	•
LED driver	••	••	-	-

• Represents basic insulation

•• Represents double or reinforced insulation

When using a non-SELV LED driver insulate the battery, LED and indicator LED in the luminaire according to the U-OUT rating of the LED driver.

5.3 Typ. LED current/voltage characteristics

The LED current in emergency mode is automatically adjusted by the EM converterLED module based on the total forward voltage of the LED modules connected and the associated battery. The start of the LED in emergency mode does not result in a current peak.

EMcLED ONC 232 LiFePO₄ 250V

Article number: 89801161

LiFePO₄ battery, 3.2 V battery voltage

700 – 750 mA battery discharge current (tolerance)

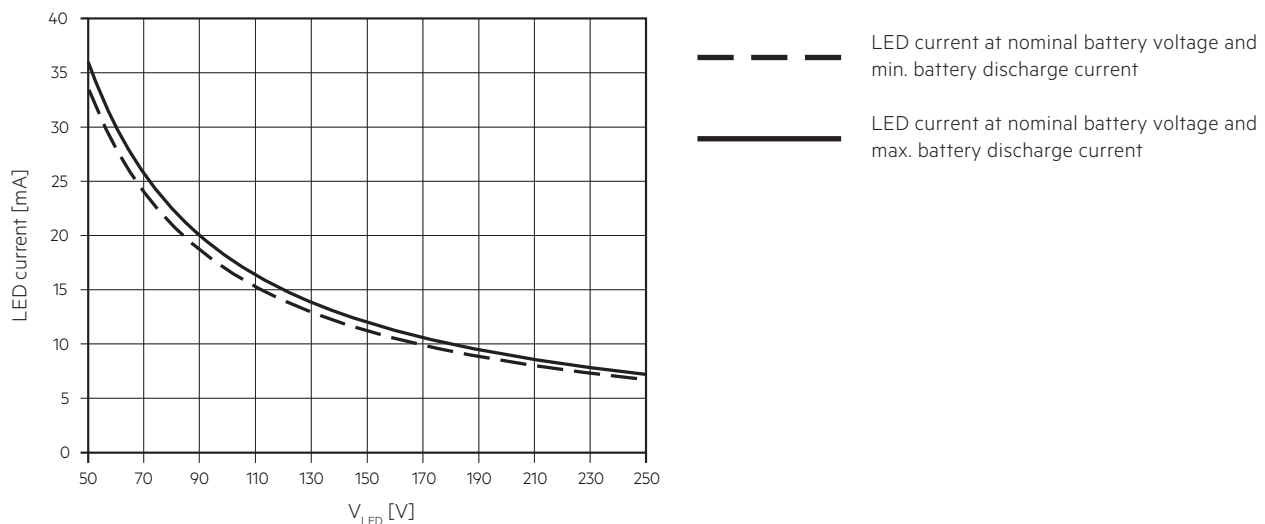

5.4 LED driver compatibility

The EM converterLED emergency unit use 3 pole technology and is compatible with most LED drivers on the market, however it is important to check that the rating of the LED driver does not exceed the values specified below:

- The max. allowed output current rating of the associated LED driver is 2 A eff (current rating of the terminals of EM converterLED) and 2.4 A peak (current rating of switching relays of EM converterLED)
- The max. allowed inrush current rating of the associated LED driver is 60 A peak for 1 ms or 84 A for 255 μ s (inrush current rating of switching relay of EM converterLED)
- The max. allowed output voltage (U-OUT) of the associated LED driver applied to the EM converterLED output is 450 V (voltage withstand between adjacent contact of the single switching relay of the EM converterLED)
- The max. allowed LED load of the associated LED driver is 150 W in operation. The load must be an LED module.

Check compatibility with short function tests (duration of several seconds).

6. Functions

6.1 Status indication LED

System status is indicated by a green LED.

Note:

The status indication LED switches off if the battery does not reach the full capacity (3.6V battery voltage) within 20 – 24 hours.

If this occurs disconnect the mains voltage and operate the device in emergency mode for approximately one hour. Afterwards apply the mains voltage again and recharge the battery for 24 hours.

If the failure occurs again replace the battery.

7. Battery data

7.1 Battery selection

EMcLED ONC 232 LiFePO₄ 250V, 3 h

			Type	EMcLED ONC 232 LiFePO ₄ 250V	
			Article no.	89801161	
			Duration	3 h	
Technology and capacity	Design	Number of cells	Type	Article no.	Assignable batteries
LiFePO ₄ 3,3 Ah 26650 cell	soft pack	1 x 1	Accu-LiFePO ₄ 3.3Ah 1S1P	05529134	•

7.2 Battery charge / discharge data

EMcLED ONC 232 LiFePO₄ 250V, 3 h, LiFePO₄

		Type	EMcLED ONC 232 LiFePO ₄ 250V
		Article no.	89801161
		Duration	3 h
Battery charge time	Initial charge	24 h	
	Fast recharge	24 h	
	Trickle charge	continuously and battery voltage controlled	
Charging current	Initial charge	250 – 290 mA	
	Fast recharge	250 – 290 mA	
	Trickle charge [Ⓢ]	250 – 290 mA / 0 mA	
Discharge current range [Ⓢ]		700 - 750 mA	
Charge voltage range [Ⓢ]		2.0 – 3.65 V per cell	
Discharge voltage range		3.65 – 2.60 V per cell	

[Ⓢ] Automatic recharge when battery voltage falls below 3.4 V. Charger off (0 mA) when battery voltage exceeds 3.6 V.

Note: Battery protected against operation at excessive temperatures (charging stopped when battery cell temperature < -5 °C or > 60 °C).

The emergency lighting LED driver will recharge the battery normally after running the test of 61347-2-7 CL 22.3 (abnormal operating conditions).

[Ⓢ] The battery will not be charged below 2.0 V.

[Ⓢ] The discharge current varies depending on the battery voltage and the LED voltage to maintain the constant output power.

7.3 Accu-LiFePO₄

Capacity 3.3 Ah

International designation	IFpR 27/67
Battery voltage/cell	3.2 V
Cell type	26650
Case temperature range to ensure 4 years design life	+55 °C
Max short term battery case tc point temperature (reduced lifetime)	70 °C
Max. number discharge cycles	50 cycles total
Max. storage time	12 months at +5 °C to +25 °C

Only use Tridonic batteries.

7.4 Wiring batteries

To inhibit inverter operation disconnect the batteries by removing the connection at battery side.

For further informations refer to corresponding battery datasheet.

7.5 Storage, installation and commissioning

Relevant information about storage conditions, installation and commissioning are provided in the battery datasheets.

8. Miscellaneous

8.1 Maximum number of switching cycles

EM converterLEDs are tested with 50,000 mains switching cycles of the associated LED driver.

8.2 Battery replacement

After a battery replacement and a subsequent full charge cycle (24 h) a duration test is mandatory to prove that with the new battery the rated duration is achieved.

8.3 Mains-connected transformers

The EM converterLED does not contain mains-connected windings of transformers.

8.4 Additional information

Additional technical information at www.tridonic.com → Technical Data

Lifetime declarations are informative and represent no warranty claim.
No warranty if device was opened.