

Sensors & Controls

DALI MSensor 02

Manual



TRIDONIC

Table of Contents

1. Validity	4
1.1. Copyright	4
1.2. Imprint	4
2. Safety instructions	5
2.1. Intended use	5
2.2. Dangers associated with the operation of the system	5
3. New features	6
3.1. New grouping concept	6
3.2. Reaction of DALI MSensor 02 to scene recalls	6
3.3. Presence synchronisation with other DALI MSensor 02 groups	6
3.4. Extended operating modes for integration in other control systems	6
4. Description	7
5. Installation	8
6. Commissioning and settings	9
6.1. Group assignment by using rotary switch	9
6.2. Group assignment by using masterCONFIGURATOR	10
6.3. Replacing a faulty DALI MSensor (V1.7 or earlier)	10
7. Functions	11
7.1. Constant light control	11
7.2. Presence control	16
7.3. Remote control	22
8. Special DALI settings	27
8.1. DALI concept	27
8.2. Reaction to DALI commands	27
8.3. Implementation of DALI commands in other comfortDIM controllers	30
9. Enhanced functionality	31
9.1. Indirect master mode	31
9.2. Slave mode	31
10. Practical examples	33
10.1. Individual office rooms	33
10.2. Corridor	35
10.3. Presence synchronisation for corridor with office rooms	36
11. Compliance	37
11.1. CE conformity	37
11.2. EMC standards	37

Table of Contents

12. Reference list 38

12.1. Related documents	38
12.2. Downloads	38
12.3. Additional information	38

13. Appendix 39

13.1. Commands for broadcast and luminaire groups	39
13.2. Commands to DALI address	40

Scope of documentation

These operating instructions are valid for the DALI MSensor 02. For better distinction from previous versions the DALI MSensor 02 carries imprints with the information "Version 02" or "Firmware version V2.00".

NOTICE

The DALI MSensor 02 behaves differently to previous versions (V1.7 and earlier). The DALI MSensor is therefore only backward compatible to a limited extent.

- _ Please pay attention to notes in the individual chapters!
- _ For version V1.7 or earlier sensors: pay attention to the notes in the respective documentation!

The DALI MSensor 02 is configured in the masterCONFIGURATOR software (V2.02. or later). Using older versions of the software to configure the DALI MSensor 02 will result in incorrect operation.

- _ Please make sure you are using an up-to-date version of the masterCONFIGURATOR software.

TRIDONIC GmbH & Co KG is constantly striving to develop all its products. This means that there may be changes in form, equipment and technology.

Claims cannot therefore be made on the basis of information, diagrams or descriptions in these instructions.

The latest version of these operating instructions is available on our home page at

<http://www.tridonic.com/com/en/operating-instructions.asp>

1.1. Copyright

This documentation may not be changed, expanded, copied or passed to third parties without the prior written agreement of TRIDONIC GmbH & Co KG.

We are always open to comments, corrections and requests. Please send them to info@tridonic.com.

1.2. Imprint

Tridonic GmbH & Co KG
Färbergasse 15
6851 Dornbirn
Austria

T +43 5572 395-0

F +43 5572 20176

www.tridonic.com

Safety instructions

The instructions in this section have been compiled to ensure that operators and users of the DALI MSensor 02 from Tridonic are able to detect potential risks in good time and take the necessary preventative measures.

The operator must ensure that all users fully understand these instructions and adhere to them. This device may only be installed and configured by suitably qualified personnel.

2.1. Intended use

2.1.1. Proper use

Multi-sensor for DALI system. The device may only be used for this intended purpose.

2.1.2. Improper use

Outdoor use. Extensions and modifications to the product.

WARNING!

Improper use could result in injury, malfunction or damage to property.
It must be ensured that the operator informs every user of existing hazards.

2.2. Dangers associated with the operation of the system

DANGER!

Danger of electrocution
Disconnect the power to the entire lighting system before working on the lighting system!

CAUTION!

Risk of damage caused by condensation
Prior to commissioning the system, wait until the control device is at room temperature and completely dry!

CAUTION!

Risk of damage caused by humidity
Only use the control device in dry rooms and protect it against humidity!

CAUTION!

Electromagnetic compatibility (EMC)
Although the Tridonic control device meets the stringent requirements of the appropriate directives and standards on electromagnetic compatibility, it could potentially interfere with other devices under certain circumstances!

New features

3.1. New grouping concept

The DALI MSensor 02 only assigns one DALI group, the luminaire group. The notion of a sensor group has been omitted from the new group concept. This has resulted in changed behaviour in response to some DALI commands.

3.2. Reaction of DALI MSensor 02 to scene recalls

The way that the DALI MSensor 02 responds to scene recalls can be set. For example, it is possible to activate light control by the DALI MSensor 02 by calling up a scene.

3.3. Presence synchronisation with other DALI MSensor 02 groups

The DALI MSensor 02 makes it possible to set up presence synchronisation between several DALI MSensor 02 groups. In doing so, it is possible to specify how the DALI MSensor 02 should respond to any presence in other groups.

3.4. Extended operating modes for integration in other control systems

Two new operating modes which are specially optimised to support integration into non-Tridonic control systems have been built into the DALI MSensor 02.

Description

The DALI MSensor 02 is a digital controller in the comfortDIM product range that can be used to control the control gear of a DALI group collectively. The sensor combines three functions in one control device:

- _ Constant light control
- _ Presence-based control
- _ Remote control

The DALI MSensor 02 supports three modes for use in combination with a higher-level DALI master controller:

- _ Direct master mode
- _ Indirect master mode
- _ Slave mode

i NOTICE

The following chapters deal with Direct master mode in detail and are only valid for this mode. In chapter "Enhanced functionality" the other two modes are dealt with briefly.

The DALI MSensor 02 is available in four different housing designs:

Fitted in luminaire

Recessed into ceiling

Surface-mounted

Box-mounted

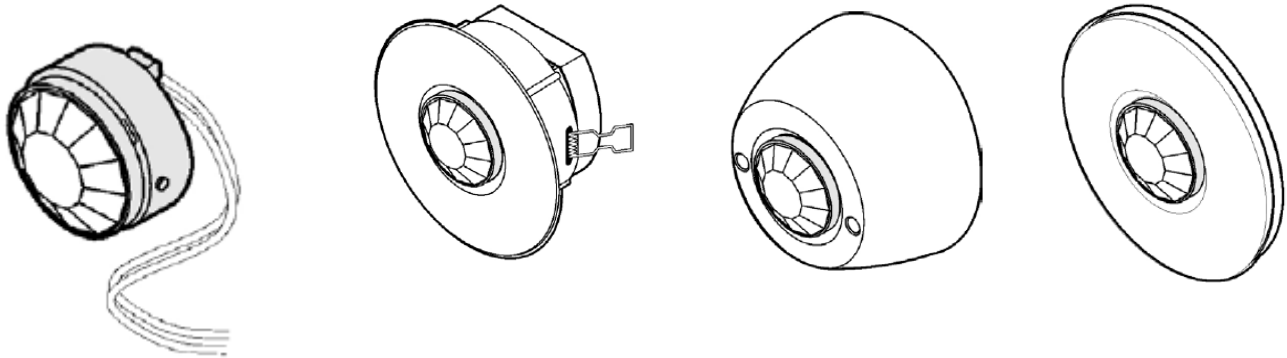

The DALI MSensor 02 is designed for the following principal applications:

- _ Individual offices
- _ Open-plan offices
- _ Training/presentation rooms
- _ Corridors, passageways and garages

The DALI MSensor 02 either controls all the units on the DALI circuit or a DALI group. The DALI MSensor 02 is Multi-master compatible, i.e. it can be used in conjunction with other DALI controllers in the comfortDIM product range. This allows the DALI MSensor 02 to be addressed and grouped in the same way as DALI control gear and makes it easy to configure the system. The DALI MSensors 02 is configured in the masterCONFIGURATOR software (V2.02. or later).

Installation

The DALI MSensor 02 is connected directly to the DALI circuit and does not require its own power supply. It can be connected to the DALI circuit without bothering about polarity. Power is supplied via the DALI circuit. The sensor draws 6 mA.

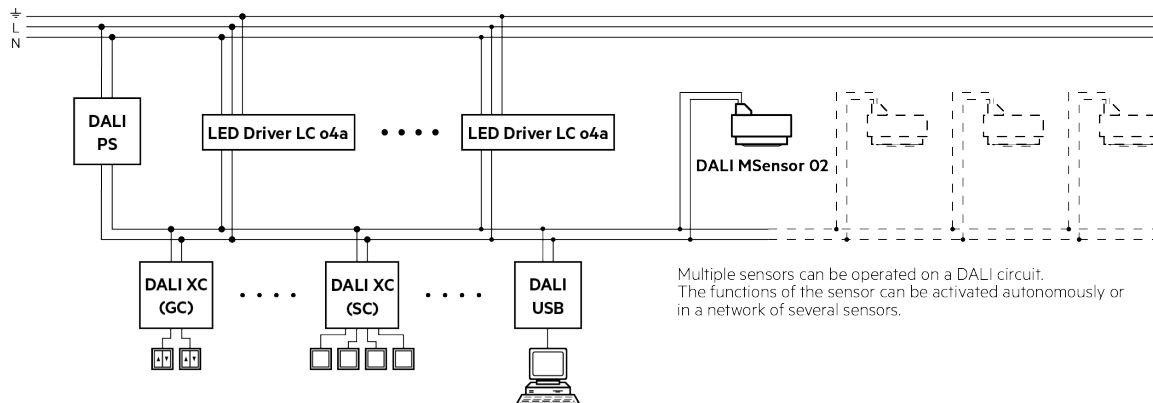

i NOTICE

A maximum of 12 DALI MSensors 02 can be operated on a single DALI circuit. If more sensors are connected, the increased data traffic this causes has an adverse affect on the light control function.

Commissioning and Adaptions

The DALI MSensor 02 either controls all the devices on the DALI circuit or a DALI group. To enlarge the presence detection area, it is possible to assign the same destination to several DALI MSensors 02. To achieve this, simply assign the sensors to the same DALI group.

The DALI MSensor 02 is configured in the masterCONFIGURATOR software (V2.02. or later). The DALI MSensor 02 can be assigned to a specific effective range. In addition, the parameters of the individual functions can be individually adjusted. There are two ways of obtaining assignment to an effective range:

- _ Group assignment by using rotary switch
- _ Group assignment by using masterCONFIGURATOR software

i NOTICE

Luminaires must not belong to more than one DALI group! Otherwise the sensors will not interpret commands sent to the luminaire correctly.

Unlike other DALI controllers, a DALI address is assigned to the DALI MSensor 02 during addressing. This reduces the total number of available DALI addresses. This must be taken into account when designing the DALI circuit!

Extending an existing DALI circuit

The DALI MSensor 02 can be used in an existing DALI circuit when a system is extended if the DALI MSensor 02 controls its own group. It is not possible to operate a DALI MSensor 02 and a DALI MSensor (V1.7 or earlier) in the same DALI group. Because of the modified grouping concept, there is no synchronisation of constant light control and presence detection between the two equipment generations.

6.1. Group assignment by using rotary switch

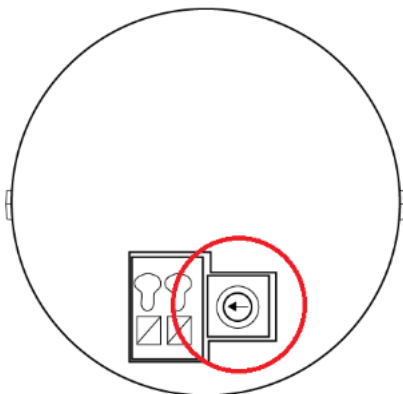

The effective range of the DALI MSensor 02 is set using the rotary switch at the rear of the sensor. All control gear located within the previously set effective range is controlled by the sensor.

Rotary switch setting	Effective range (group)
0	All (broadcast)
1	0
2	1

Commissioning and Adaptions

3..9	2..8
A..F	9..14

6.2. Group assignment by using masterCONFIGURATOR

The effective range of the DALI MSensor 02 can be set in the masterCONFIGURATOR software (V2.02 or later). When this assignment method is used, the position of the sensor's rotary switch is ignored and the assignment selected in the masterCONFIGURATOR software is active. If the group assignment in the masterCONFIGURATOR software is cancelled, the assignment set using the rotary switch becomes effective.

6.3. Replacing a faulty DALI MSensor (V1.7 or earlier)

It is only possible to replace a faulty DALI MSensor (V1.7 or earlier) by a DALI MSensor 02 if specific preconditions are met:

- _ Make sure that there is no other DALI MSensor (V1.7 or earlier) in the DALI group in question!
- _ Make sure that the faulty DALI MSensor (V1.7 or earlier) is not influenced by other DALI controllers (e.g. by the fact that a DALI GC activates daylight-based control via the sensor group).

Further adaptation is required in the case other applications:

- _ If you have any queries, please contact Tridonic Technical Support.
- _ Alternatively, it is possible to use the masterCONFIGURATOR software to install the V1.7 firmware in the DALI MSensor 02. The DALI MSensor 02 will then behave in the same way as previous-generation DALI MSensors.

Functions

The DALI MSensor 02 has the following functions and user interfaces:

- _ Constant light control by means of ambient light sensor
- _ Presence-based control by means of PIR motion sensor or presence detector
- _ Remote control via an infrared input for two different IR remote controls

7.1. Constant light control

7.1.1. Description

Constant light control makes it possible to match the lighting in a room to the naturally available ambient light. To do this, the ambient light sensor monitors the illuminance in the room, compares it to the previously set brightness setpoint and dims the light until the received illuminance matches the desired setpoint. If several DALI MSensors 02 are used in the same luminaire group, the light is dimmed until the light value is no longer less than the setpoint at every sensor.

Where ambient light values are high, this can result in ambient light-based bright-out and bright-in. If the measured illuminance exceeds a specified threshold value for a period of time that is longer than the specified delay time, the luminaire group is switched off by the DALI MSensor 02. This also applies in cases where motion is detected in the room. The luminaire group is switched on again as soon as the measured illuminance falls below the brightness setpoint.

The Constant light control function ensures that the illuminance in the room remains constant and changes due to variable amounts of ambient light in the room are compensated for. This produces greater comfort, illumination is always properly adjusted, and it also saves energy.

Detection area of the ambient light sensor

The detection area of the sensor is sized so that a relatively large area, rather than just an individual location on the task area, is covered and assessed. This ensures that objects being moved around cannot cause incorrect measurements.

Constant light control

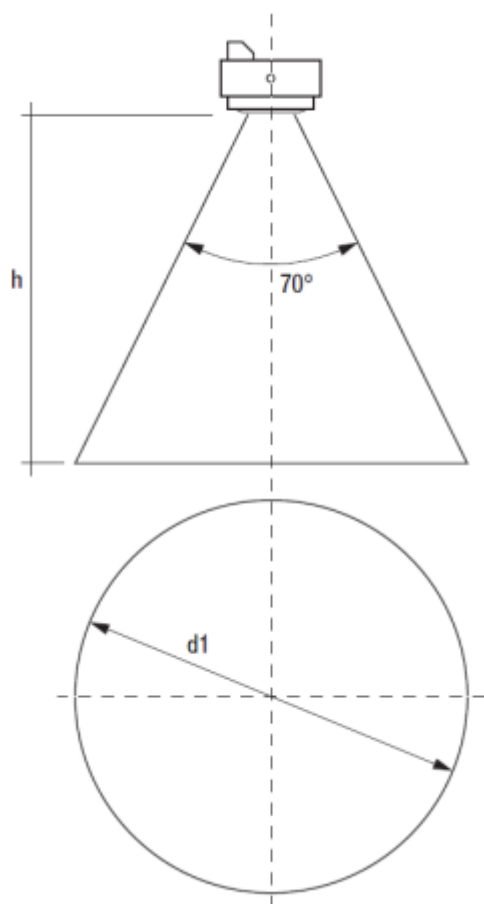

The diameter of the detection area depends on the detection angle of the sensor and the height at which it is mounted.

Calculating the diameter:

$$d1 = 2 \times \tan(0.5 \times 70^\circ) \times h$$

Typical example values of detection area:

Height h	Diameter d1
2.0 m	2.8 m
2.5 m	3.5 m
3.0 m	4.2 m
3.5 m	4.9 m
4.0 m	5.6 m

7.1.2. Operating modes

The ambient light sensor has three operating modes. Constant light control can be activated or deactivated. Constant light control can also be deactivated temporarily.

Constant light control

Operating mode	Description
"enabled"	Light control of the luminaire group is activated by triggering the DALI MSensor 02.
"disabled"	The light control of the DALI MSensor 02 is permanently deactivated. A fixed setpoint in the luminaire group is invoked by triggering the DALI MSensor 02.
"temporarily disabled"	Light control can be temporarily deactivated by a manual intervention on another DALI controller. Doing so temporarily switches off light control. The luminaires remain adjusted to the corresponding setpoint. Light control is reactivated at the next switch-on or by an activation command.

7.1.3. Commissioning

Setting operating modes

The individual operating modes can be set by using the masterCONFIGURATOR software (V2.02 or later) (see [Reference list](#), p. 38).

Setting the brightness setpoint

The brightness setpoint is set by using an IR SMART Controller, DALI RC or masterCONFIGURATOR.

i NOTICE

The factory settings of the ambient light sensor are appropriate for normal conditions in a typical office room. Factors such as the room height, type of furniture and nature of the floor can make it necessary to make adjustments.

- _ Check that ambient light control adjusts the lighting to desired levels.
- _ In case of incorrect operation or unsatisfactory results: adjust the brightness setpoint.

i NOTICE

A suitable brightness setpoint is typically defined by using a lux meter to make a localised brightness measurement. The results obtained may vary depending where the measurement is made and what the external lighting conditions are.

- _ Check ambient light control at various locations within the measuring area and under varying external lighting conditions.
- _ Make sure that the selected brightness setpoint takes into account varying conditions.

Procedure with REMOTECONTROL IR6 remote

For the names of the buttons with letters, see the figure showing the REMOTECONTROL IR6 remote.

- _ Set the desired brightness by pressing the Up/Down button (F and G)
- _ Save the new brightness setpoint by pressing the SET button (C)
- > DALI MSensor 02 briefly dims the luminaire group up and down

Constant light control

Procedure with DALI-RC (not available anymore!)

For the names of the buttons with letters, see the figure showing the DALI RC.

- _ Set the desired brightness by pressing the +/- button (J)
- _ Save the new brightness setpoint by pressing the AUTOMATIC button (K) for at least 3 seconds.
-> DALI MSensor 02 briefly dims the luminaire group up and down

Procedure with masterCONFIGURATOR

- _ Directly enter the brightness setpoint

Setting the ambient light-based bright-out and bright-in

This function can be activated or deactivated. The individual parameters can be adjusted. All settings can be made by using the masterCONFIGURATOR software (V2.02 or later) (see [Reference list](#), p. 38).

7.1.4. Tricks and hints

Position the ambient light sensor correctly

Ambient light control is based on measuring reflected artificial light and daylight. This light must be detected correctly and completely. Prevent measurements being falsified by other light sources. Positioning the ambient light sensor correctly is crucial:

1. In order to be able to control ambient lighting properly, the sensor must be able to detect the light from the controlled luminaires completely.

- _ Position the sensor so that the sensor's detection area lies within the area that is lit by the controlled luminaires.

2. If the sensor is directly exposed to other light sources, this falsifies the results obtained and the reflected artificial light and daylight can no longer be detected correctly.

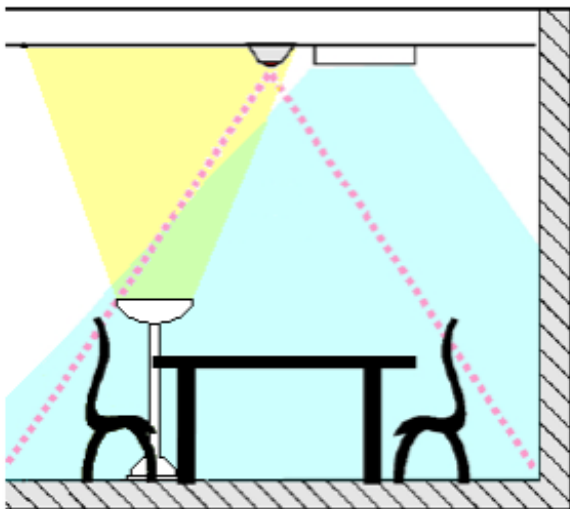

- _ Position the sensor so that it is not directly exposed to other artificial light sources (e.g. free-standing luminaires in the room).

Constant light control

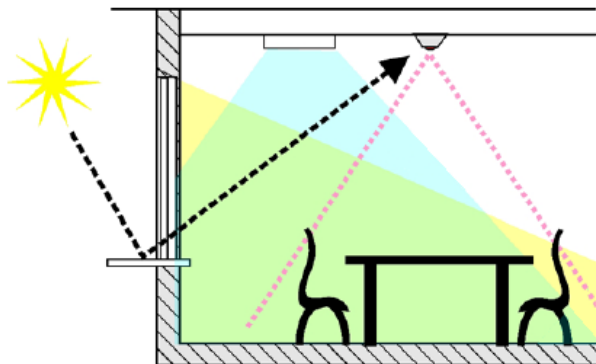

- _ Position the sensor so that it is not directly exposed to sunlight:
 - _ Make sure that the detection area of the sensor lies within the room.
 - _ Make sure that the sensor is far enough away from any window area.
 - _ Make sure that any glare or sunlight reflected by shiny glass or metal surfaces cannot hit the sensor.

3. If more than one sensor is being used in a room it is possible that the detection areas of the sensors may overlap. Overlapping detection areas may cause the different control circuits to affect one another and this may lead to false results.

- _ Position the sensors so that their detection areas do not overlap.

Presence control

7.2. Presence control

7.2.1. Description

Presence-based control makes it possible to link illuminance to the presence or absence of people. The light is switched on as soon as a person enters a room. When the person leaves, the light is set to a predefined light value after a certain time lapse. Presence-based control offers the benefits of saving energy as well as the convenience of automatic lighting control.

The device has different operating modes and profiles that can be adjusted in the masterCONFIGURATOR software (V2.02 or later).

NOTICE

The presence-based control of the DALI MSensor 02 reacts to moving thermal radiation from people. Other heat sources (e.g. photocopiers, radiators, etc.) may have an adverse affect on presence-based control. Make sure that there are no other heat sources in the immediate vicinity of the sensor.

Detection area of the motion sensor

The detection area of the motion sensor consists of a pattern of various measurement fields. The following conditions must be met in order for an object to be detected reliably:

- _ The object must move from one measurement field to another
- _ The temperature of the object must be different from the background temperature

Presence control

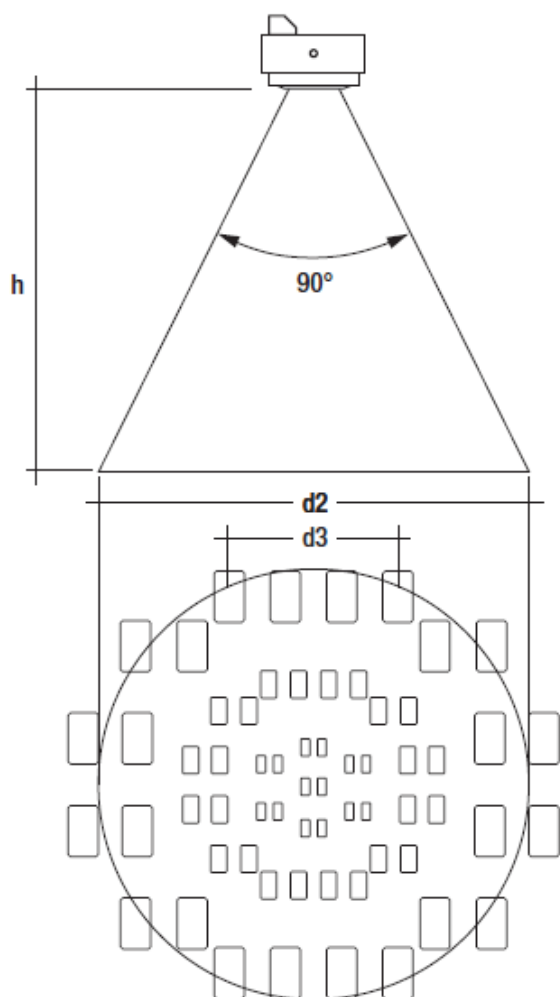

The diameter of the detection area depends on the detection angle of the sensor and the height at which it is mounted. The mounting height also has an effect on the sensor's accuracy.

The position and mounting height produce two different detection areas:

- _ In the centre of the detection area, the sensor operates as a presence detector (d3), i.e. objects are detected merely by arm movements, etc. and do not need to move through the room. (This applies up to a maximum height of 3 m)
- _ Throughout the entire detection area, the sensor operates as a motion sensor (d2), i.e. objects are detected when they move through the room

Calculating the diameter:

$$d2 = 2 \times \tan(0.5 \times 90^\circ) \times h$$

Typical example values of detection area:

Height	d2	d3
2,0 m	4 m	1,6 m
2,5 m	5 m	2 m

Presence control

3.0 m	6 m	-
3.5 m	7 m	-
4.0 m	8 m	-

i NOTICE

The recommended maximum room height is 3 m for office applications and 4 m for corridor applications. For presence detection, it is vital that arm movements, etc. can be detected. Position the sensor on the ceiling so that the room user's hands are located in the centre of the detection area and are not concealed by display screens, backs, etc.

7.2.2. Operating modes

The motion sensor has four different operating modes.

Operating mode	Description
"enabled"	The light is switched on or off automatically in response to the presence of a person.
"enabled (only OFF)"	The sensor switches off if there is no motion detected in the detection area, but does not switch on again even if motion is detected. Switch-on must be obtained through a manual switch-on command (e.g. using DALI RC). The manual switch-on command (e.g. scene recall) must either be directed at the luminaire group or to all devices (broadcast) in order for presence-based control to be activated. The DALI MSensor 02 ignores switch-on commands sent to other groups.
"disabled"	The motion sensor is deactivated. The light must be switched on and off manually.
"Never-Off"	After no motion has been detected and the delay time has elapsed, the sensor dims to a low light value (absence value) but does not switch off.

Presence control

7.2.3. Profiles

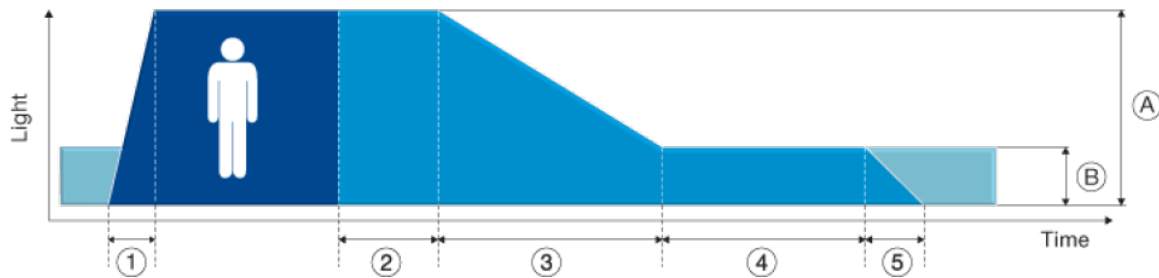

Parameter	Description	
1	Fade-in time	The time needed to reach the presence value.
A	Presence value	The value that the luminaire group assumes while a person is present in the room.
2	run-on time	The time that starts to run after the last motion is detected in a room and after which, when it elapses, the fade-down time is started. If another movement is detected in the room during the delay time, the delay time is restarted.
3	Fade time	Time in which the lighting is faded down to the absence value.
4	Switch-off delay	The time for which the absence value is maintained if no motion is detected.
B	Absence value	The value that the luminaire group assumes during the switch-off delay.
5	Fade-off time	The time needed to dim down from the absence value.

i NOTICE

If the motion sensor is switched off manually during operation, it is temporarily deactivated. The duration of deactivation depends on the value of the "Dead time (manual OFF)" parameter. If the sensor detects motion during the time lag, it restarts the time lag afresh. The motion sensor is reactivated when the time lag has elapsed.

7.2.4. Commissioning

Setting the operating mode

The individual operating modes can be set in the masterCONFIGURATOR software (V2.02 or later) (see [Reference list](#), p. 38).

Setting the profile

The individual profiles can be set in the masterCONFIGURATOR software (V2.02 or later) (see [Reference list](#), p. 38).

Setting the "Dead time (manual OFF)"

The value of "Dead time (manual OFF)" can be set in the masterCONFIGURATOR software (V2.02 or later) (see [Reference list](#), p. 38).

Presence control

7.2.5. Enhanced functionality

DALI MSensors 02 of different DALI groups can synchronise their motion detection, i.e. a DALI MSensor 02 can monitor other DALI groups with DALI MSensors 02 and respond appropriately to the "Motion detected" synchronisation command in another group. A DALI MSensor 02 can monitor up to 4 other DALI groups.

Presence control

The following parameters can be adjusted:

Parameter	Description
"Go to Presence value"	The "Motion detected" synchronisation command is interpreted in the same way as if the actual sensor detected motion.
"Go to Absence value"	The "Motion detected" synchronisation command causes the DALI MSensor 02 to maintain the absence value. If the sensor is already at the absence value, it keeps resetting the switch-off delay and remains at that value. If the sensor is in the "OFF" state, it switches to the absence value. If the sensor is at the absence value, the synchronisation command is ignored.
MASK	The DALI MSensor 02 ignores the "Motion detected" synchronisation command of the other group (factory setting).

NOTICE

In the operating mode: "enabled (only OFF)", the DALI MSensor 02 does not send synchronisation commands until the sensor has been activated by a manual switch-on command.

In the operating mode: "enabled (only OFF)", the DALI MSensor 02 does not respond to synchronisation commands until the sensor has been activated by a manual switch-on command.

Remote control

7.3. Remote control

7.3.1. Description

The DALI MSensor 02 can be operated with three remote controls:

- _ REMOTECONTROL IR6
- _ IR SMART Controller (not available anymore!)
- _ DALI RC (not available anymore!)

IR SMART Controller / REMOTECONTROL IR6

The IR SMART Controller or REMOTECONTROL IR6 is used to operate the assigned luminaire group in the DALI system. This remote control offers the following functions:

- _ Switching luminaire group on/off
- _ Dimming luminaire group up/down
- _ Activation of light control
- _ Definition of the brightness setpoint value

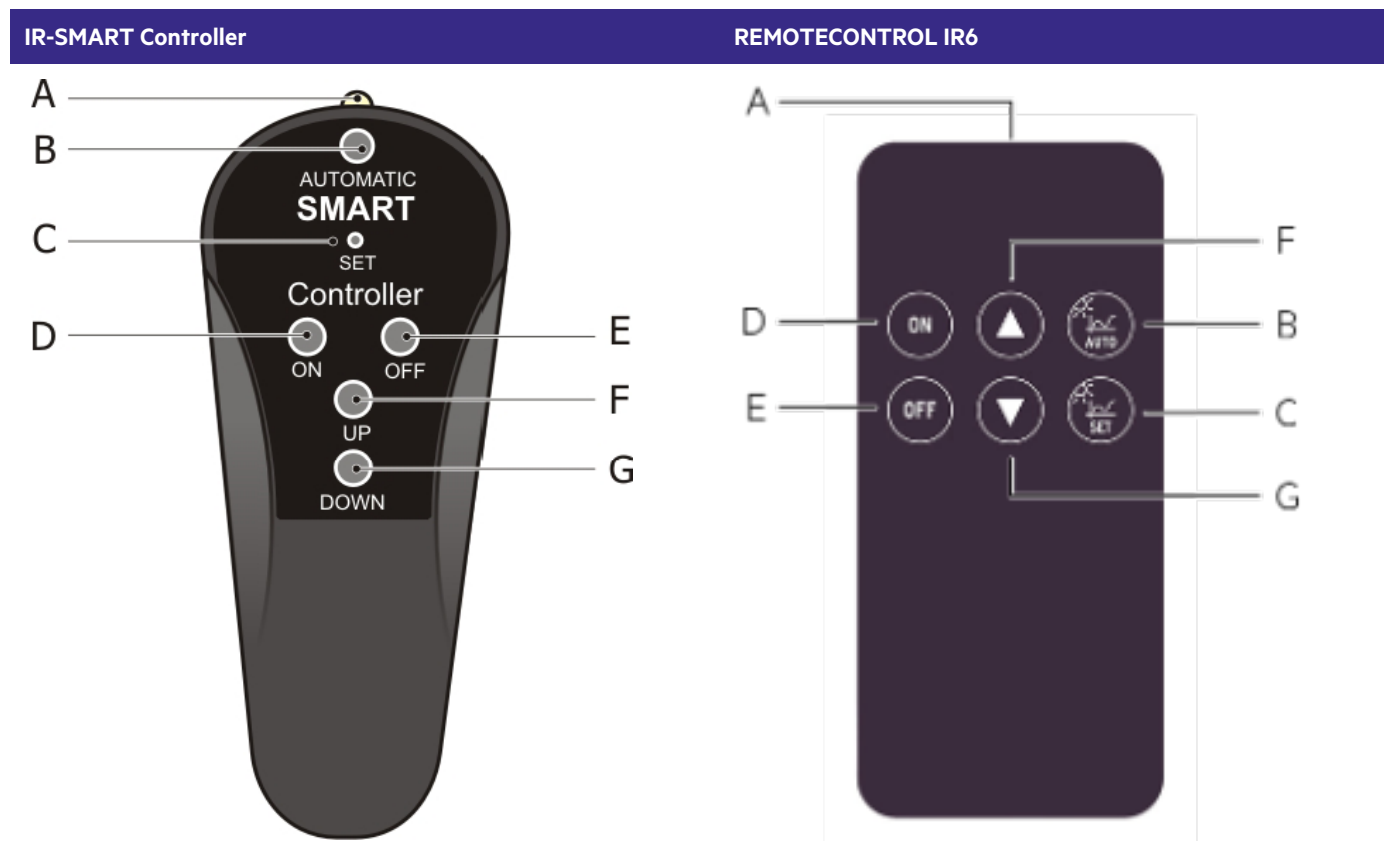

Remote control

Description		Description	
A	IR sender	E	OFF – Luminaire group OFF
B	AUTOMATIC control mode ON/OFF	F	UP – Increase light value
C	SET – Saves the current light control value	G	DOWN – Reduce light value
D	ON – Luminaire group ON		

NOTICE

This IR-SMART Controller is not available anymore!

DALI RC

The DALI RC offers the following functions:

- _ Switching all the luminaires or the selected group on/off
- _ Dimming all the luminaires or the selected group up/down
- _ Activation of light control
- _ Calling up two scenes
- _ Definition of the brightness setpoint value

In order to ensure that the remote control can be used straight away without any complicated set-up procedure, the buttons are pre-programmed with a default setting. The button assignment in User mode is as follows:

Remote control

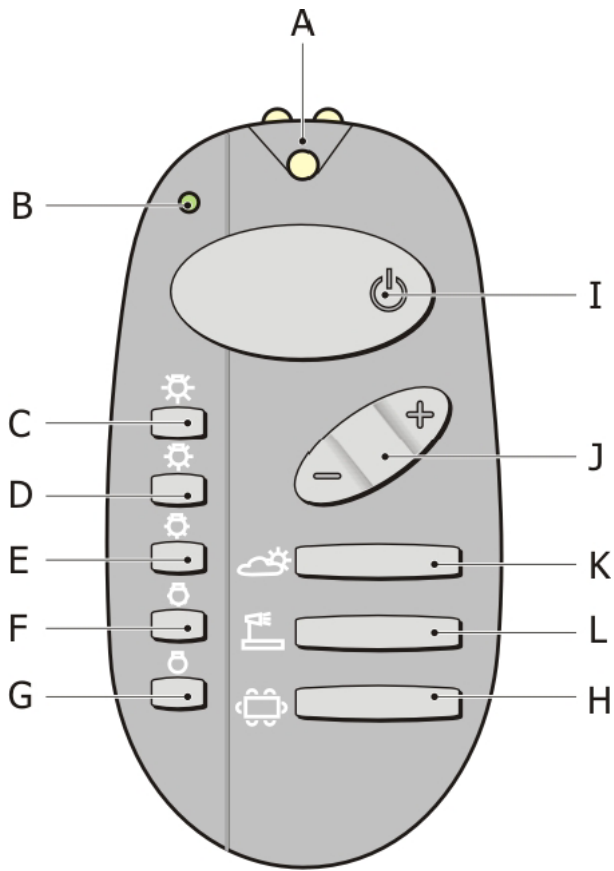

Description		Description	
A	IR sender		
B	LED - status display	I	Switch all luminaires in the DALI system ON or OFF
C	Light value 100 % brightness	J	Increase or reduce the light value (dimming the DALI system)
D	Light value 50 % brightness	K	AUTOMATIC control mode ON
E	Light value 25 % brightness	L	Call up scene 2
F	Light value 12 % brightness	H	Call up scene 1
G	Light value 6 % brightness		

i NOTICE

This DALI RC is not available anymore!

Remote control

7.3.2. Commissioning

Changing the button assignment (DALI RC only)

The assignment of the DALI RC's buttons can be modified in the masterCONFIGURATOR software (V2.02 or later) (see [Reference list](#), p. 38).

Setting the effective range (group assignment)

IR SMART Controller / REMOTECONTROL IR6

The effective range of the IR SMART Controller or REMOTECONTROL IR6 is the luminaire group that is set on the DALI MSensor 02. This setting is made via the DALI MSensor 02.

DALI RC

The rotary switch in the battery compartment of the remote control is used for setting the group to be controlled by the remote control:

- _ Position 0 means that the commands apply to all the control gear
- _ Positions 1-15 mean that the commands apply only to the corresponding group

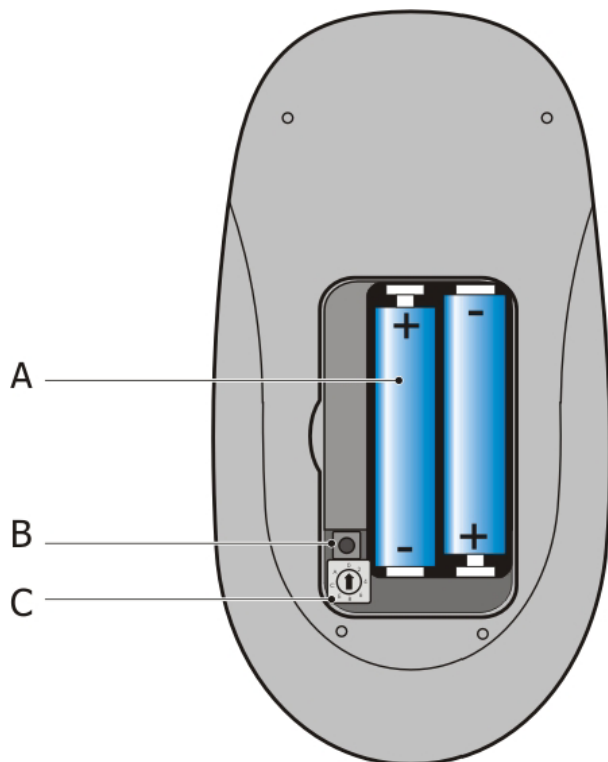

	Description		Description
A	Battery	C	Rotary switch [Group]
B	[Modes] button		

Remote control

Assignment of rotary switch setting to effective range

Rotary switch setting	Effective range (group) DALI RC
0	All (broadcast)
1	0
2	1
3...9	2...8
A...F	9...14

NOTICE

If the masterCONFIGURATOR software is used to customise the button assignments, the rotary switch in the battery compartment of the remote control is disabled. The commands will then only apply to the luminaire group selected on the DALI MSensor 02.

Special DALI settings

8.1. DALI concept

The behaviour of control devices is not currently described in the DALI standard. This is why the DALI MSensor 02 responds to some DALI commands in a special manner, as defined by Tridonic. This ensures that the DALI MSensor 02 can be optimally combined with other products in the comfortDIM product range.

- _ Please pay attention to notes concerning DALI commands !
- _ When used in combination with other manufacturers' controllers: please check compatibility!

The DALI MSensor 02 is designed so that it can be combined with other DALI controllers. This is why the sensor responds to some DALI commands in a different way than that specified in the official DALI standard. This ensures that other DALI controllers, e.g. the DALI SC or x/e-touchPanel, can be used to affect light control.

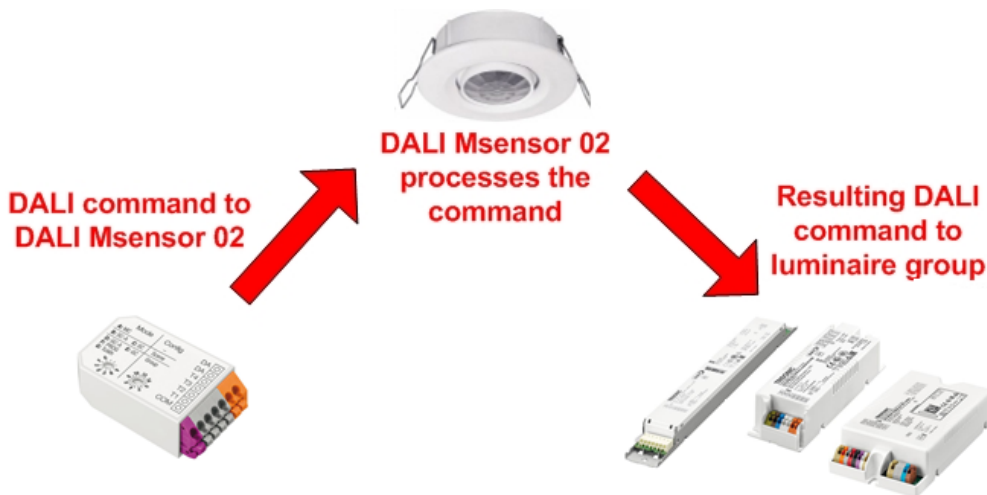

Like DALI control gear, the DALI MSensor 02 reacts to commands that are sent to it, i.e. commands sent to its DALI address, DALI group (luminaire group), or to broadcast commands.

8.2. Reaction to DALI commands

The DALI MSensor 02 sometimes distinguishes whether commands are sent to its DALI address or to its DALI group or whether commands are broadcast commands. This chapter deals with the most important commands for communicating with other controllers and confines itself to broadcast or group commands. A detailed overview of supported DALI commands sent to a DALI address can be found in the annex.

8.2.1. Direct setpoint invocation (DALI "Direct Arc Power x" command)

In the case of direct setpoint invocation, a distinction must be made between setpoint commands greater than 0 % and setpoint commands equal to 0 %. Setpoint commands greater than 0 % act as a switch-on command. The following behaviour applies for these:

Constant light control

- _ Setpoint is invoked, light control is temporarily disabled.

Special DALI settings

Presence control

- _ In switched-off state:
presence detector is activated and changes to "Presence" state.
- _ In switched-on state:
presence detector changes to "Presence" state, delay time is restarted.

8.2.2. Switch off (DALI "OFF" command or "Direct Arc Power 0")

In the case of direct setpoint invocation, a distinction must be made between setpoint commands greater than 0% and setpoint commands equal to 0%. Setpoint commands equal to 0% act as a switch-off command. The specific DALI "OFF" command also acts as a switch-off command. The following behaviour applies for both variants:

Constant light control

- _ Luminaire group is switched off.

Presence control

- _ Presence detector changes to "Time lag (manual OFF)" state.

8.2.3. Switch on at maximum value (DALI "Recall Max" command)

Constant light control

This behaviour can be adjusted in the masterCONFIGURATOR configuration software:

- _ The maximum value of the control gear is invoked, light control is temporarily disabled or
- _ The maximum value of the control gear is invoked, light control is activated.

Presence control

- _ In switched-off state:
presence detector is activated and changes to "Presence" state.
- _ In switched-on state:
presence detector changes to "Presence" state, delay time is restarted.

Special DALI settings

8.2.4. Recall scene (DALI "Recall Scene x" command)

This behaviour can be adjusted in the masterCONFIGURATOR configuration software:

Setting	Behaviour	
automatic	Constant light control:	<ul style="list-style-type: none"> Light control is activated
	Presence-based control:	<ul style="list-style-type: none"> In switched-off state: presence detector is activated and changes to "Presence" state. In switched-on state: presence detector changes to "Presence" state, delay time is restarted.
static (standard)	Constant light control:	<ul style="list-style-type: none"> Light control is temporarily deactivated
	Presence-based control:	<ul style="list-style-type: none"> In switched-off state: presence detector is activated and changes to "Presence" state. In switched-on state: presence detector changes to "Presence" state, delay time is restarted. If the delay time runs out without a moniton detection the light control will be activated again.
off	Constant light control:	<ul style="list-style-type: none"> Luminaire group is switched off.
	Presence-based control:	<ul style="list-style-type: none"> Presence detector changes to "Time lag (manual OFF)" state.
MASK	The DALI MSensor 02 does not react to scene recall and remains in its current state (Presence detector changes to "Time lag (manual OFF)" state)	

NOTICE

Scene recalls are sent both to the DALI MSensor 02 and to the ballasts of the luminaire group. This may result in contradictory responses! To prevent this, proceed as follows:

- In the ballast, select the "MASK" setting if one of the three "automatic", "off" or "MASK" settings has been selected in the DALI MSensor 02.
- If the MSensor 02 is used in combination with an x/e-touchPANEL it is recommended to set the scenes with the x/e-touchPANEL.

Special DALI settings

8.2.5. Dimming (DALI "Up" or "Down" command)

Constant light control

This behaviour can be adjusted in the masterCONFIGURATOR configuration software:

- _ Luminaire group is dimmed, light control is temporarily deactivated or
- _ Luminaire group is dimmed. The brightness value measured after dimming is accepted as the new temporary brightness setpoint for constant light control. At the next switch-on, constant light control is reset to the previously stored brightness setpoint.

Presence control

- _ In switched-off state:
the presence detector ignores the command and remains in the "off" state.
- _ In switched-on state:
the presence detector remains in its respective state, the motion sensor profile continues.

8.3. Implementation of DALI commands in other comfortDIM controllers

If the DALI MSensor 02 is combined with other comfortDIM controllers in a DALI circuit, its behaviour can be influenced by the above-mentioned DALI commands. The following matrix lists those commands that are output by a particular device.

DALI command or device type	Direct setpoint invocation ("Direct Arc Power x")	Switch on at maximum value ("Recall Max")	Switch off ("OFF" or "Direct Arc Power 0")	Recall scene ("Recall Scene x")	Dimming ("Up" or "Down")
DALI XC (GC)	✗	✓	✓	✗	✓
DALI XC (SC)	✗	✗	✗	✓	✗
DALI XC (MC)	✓	✓	✓	✓	✓
DALI TOUCHPANEL 02	✓	✓	✓	✓	✓
DALI x/e-touchPANEL 02	✓	✓	✓	✓	✓

Extended functionality

NOTICE

In the case of the DALI XC (MC) and DALI TOUCHPANEL 02 controllers, the DALI commands that are used can be modified in the masterCONFIGURATOR software. The particular DALI command that is invoked then depends on the settings. Scene recalls using the DALI XC (SC), DALI TOUCHPANEL 02 (factory setting) or x/e-touchPANEL 02 are sent to all devices, this means that all DALI MSensors 02 with appropriate parametrisation respond to them!

Besides Direct master mode, the DALI MSensor 02 also supports two further modes for use in combination with a higher-level DALI master controller:

- _ Indirect master mode
- _ Slave mode

Ex factory, the DALI MSensor 02 is in direct master mode. The indirect master mode has to be activated over the master controller itself. The slave mode can be activated over the master controller itself or by using the masterCONFIGURATOR software.

NOTICE

If used in conjunction with an external system note the following:

- _ Make sure that the DALI MSensor 02 is compatible with the external system
- _ Make sure that the producer of the external system has conferred the right to use the DALI MSensor in conjunction with their own product

9.1. Indirect master mode

In Indirect master mode, the DALI MSensor 02 does not send any active control commands to the luminaires; it sends the measured light value, presence detection status and remote control status to a higher-level master. The master controller analyses this information and sends the corresponding control commands to the luminaires.

eDALI is used to communicate with the master. eDALI is Tridonic GmbH & Co KG's proprietary extension of the DALI standard.

9.2. Slave mode

In Slave mode, the DALI MSensor 02 do not send any active control commands to the luminaires; it has to be interrogated by a higher-level control system (master).

As in Direct master mode, the DALI MSensor 02 is given a DALI address during addressing. The brightness currently measured by the sensor and the status of the presence detector can be interrogated via this DALI address by using the "QUERY ACTUAL LEVEL" DALI request. A detailed listing and explanation of the supported DALI commands can be found in the annex.

Extended functionality

NOTICE

The remote control is inoperative in Slave mode.

The rotary switch at the rear of the DALI MSensor 02 is inoperative in Slave mode.

Practical examples

10.1. Individual office rooms

10.1.1. Requirements

- _ Switch on and switch off by means of momentary-action switch
- _ Switch off by means of motion sensor
- _ Ambient light control of illuminance

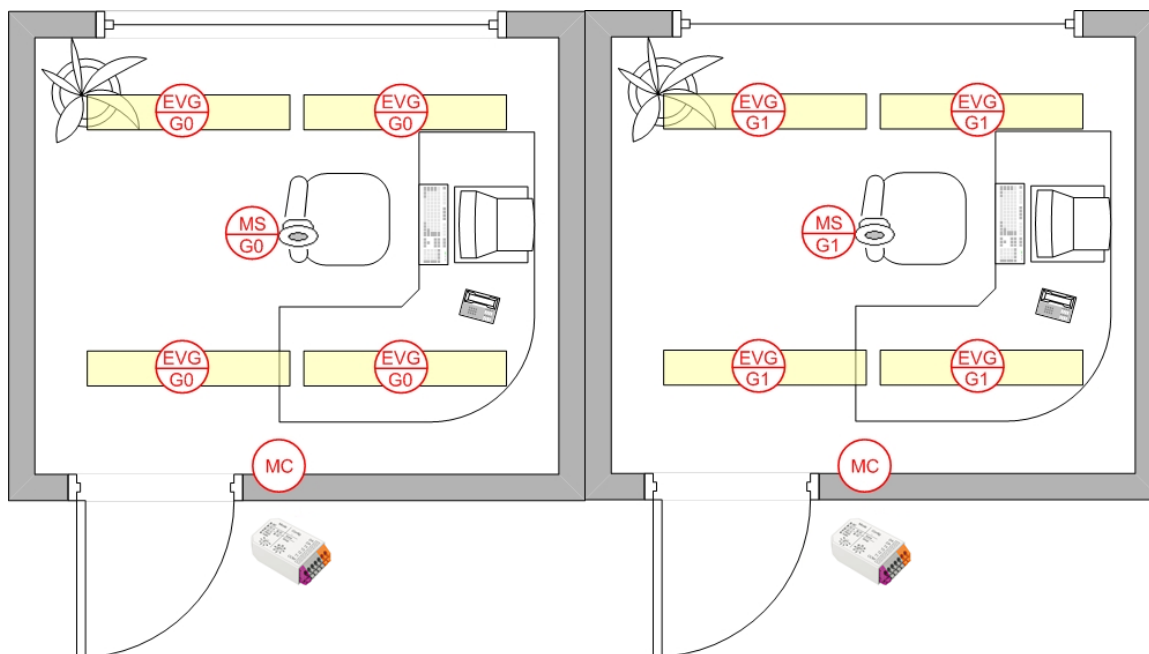

Practical examples

10.1.2. Grouping/configuration:

	Room A	Room B
MSensor	Group 0 (switch position 1) Configuration: Scene 0: Automatic control	Group 1 (switch position 2) Configuration: Scene 1: Automatic control
DALI XC (MC)	<p>The DALI XC (MC) is used to switch on light control and to switch off the lighting</p> <ul style="list-style-type: none"> _ Activation of light control with scene recall _ Switch off with OFF <p>Configuration of input 1: Target: Group 0 Function: Momentary-action switch Command X: Recall scene 0</p> <p>Configuration of input 2: Target: Group 0 Function: Momentary-action switch Command X: OFF</p>	<p>The DALI XC (MC) is used to switch on light control and to switch off the lighting</p> <ul style="list-style-type: none"> _ Activation of light control with scene recall _ Switch off with OFF <p>Configuration of input 1: Target: Group 1 Function: Momentary-action switch Command X: Recall scene 1</p> <p>Configuration of input 2: Target: Group 1 Function: Momentary-action switch Command X: OFF</p>

Practical examples

10.2. Corridor

10.2.1. Requirements

- _ Switch on and switch off using motion sensor
- _ Ambient light control of illuminance
- _ Corridor and staircase are separately controlled

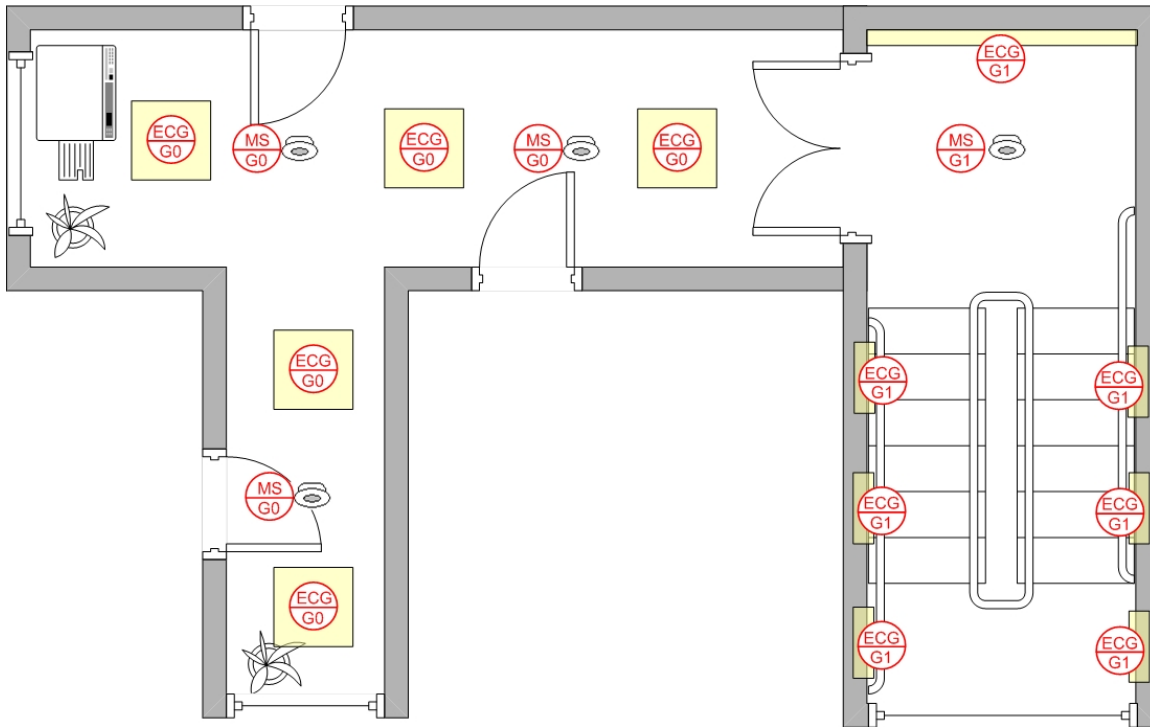

10.2.2. Grouping:

	Corridor	Staircase
MSensor	Group 0 (switch position 1)	Group 1 (switch position 2)

i NOTICE

In order to enlarge the presence detection area, several DALI MSensors 02 are installed in the corridor. All these sensors must be assigned to the same luminaire group. If there are multiple DALI MSensors 02 in a group, light control behaves as follows:

- _ the light value is raised until it is no longer less than the setpoint value at any of the sensors.

Practical examples

10.3. Presence synchronisation for corridor with office rooms

10.3.1. Requirements

- _ Switch on and switch off using motion sensor
- _ Ambient light control of illuminance
- _ Lighting in the corridor must remain at a basic lighting level (10 %) as long as at least one office is occupied. The lighting must only be switched off entirely when no office is occupied and there is nobody in the corridor.

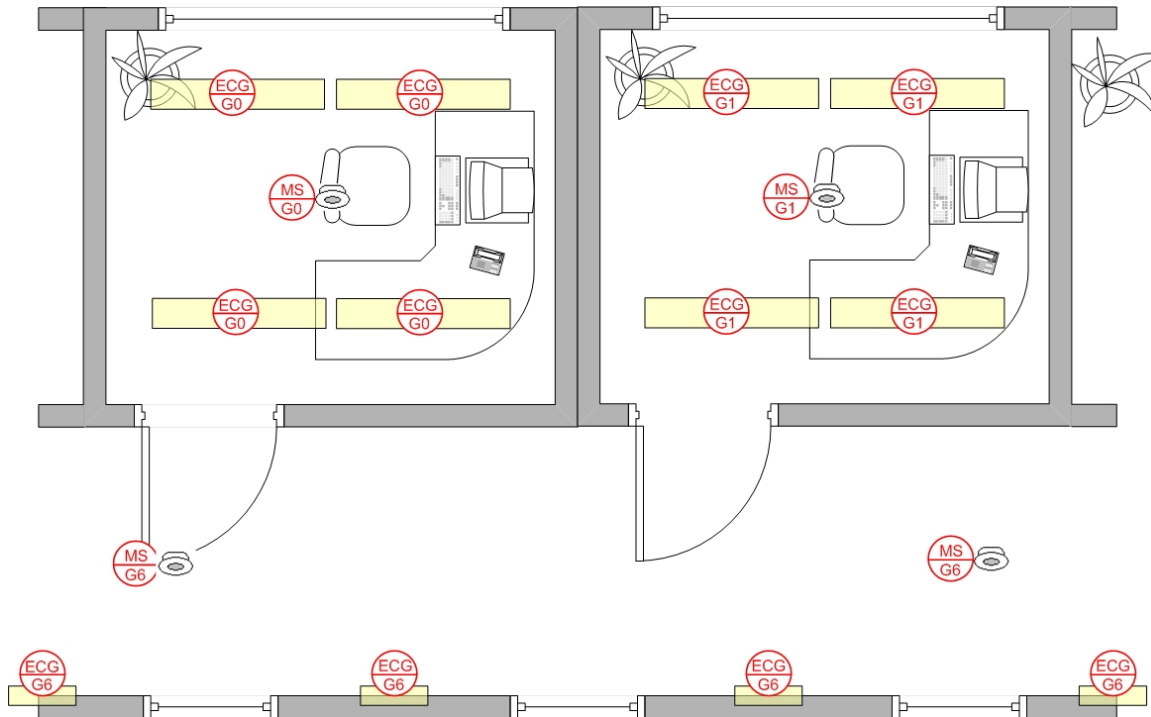

10.3.2. Grouping / configuration

	Office A	Office B	Corridor
MSensor	Group 0 (switch position 1)	Group 1 (switch position 2)	Group 6 (switch position 7)
			Configuration Reaction to presence in other groups: Group: 0 and 1 Function: Go to Absence value

Compliance

11.1. CE conformity

Tridonic declares that the DALI MSensor 02 product complies with the relevant EC directives.

11.2. EMC standards

The compliance declaration for the ballast allows the manufacturer to assume that with the exception of radio interference all the EMC requirements are met also for the luminaire. Radio interference is heavily dependent on the design of the luminaire and the wiring so it has to be measured in conjunction with the luminaire.

The limit values for EMC are given in the following standards:

- _ EN 55015 (Limit values and measuring procedures for radio interference)
- _ EN 61547 (EMC requirements)

With the CE symbol on its products and with the compliance declaration, Tridonic confirms that its products comply with EMC standards.

Reference list

12.1. Related documents

- _ Documentation masterCONFIGURATOR:
http://www.tridonic.com/com/en/download/Manual_masterConfigurator_en.pdf
- _ Data sheet DALI MSensor 02:
http://www.tridonic.com/com/en/download/data_sheets/DS_DALI_MSensor_02_en.pdf
- _ Declarations of conformity:
<http://www.tridonic.com/com/en/declarations-of-conformity.asp>
- _ Certificates:
<http://www.tridonic.com/com/en/certificates.asp>
- _ ENEC certificate:
http://www.tridonic.com/com/en/download/certificates/ENEC_IK-1965_DALI_MSensor.pdf

12.2. Downloads

- _ Tridonic software: <http://www.tridonic.com/com/en/software.asp>
- _ Download masterCONFIGURATOR: <http://www.tridonic.com/com/en/software-masterconfigurator.asp>

12.3. Additional information

- _ DALI manual: http://www.tridonic.com/com/en/download/technical/DALI-manual_en.pdf
- _ Guarantee conditions: <http://www.tridonic.com/com/en/guarantee.asp>
- _ Data sheets: <http://www.tridonic.com/com/en/data-sheets.asp>
- _ Environmental declarations: <http://www.tridonic.com/com/en/environmental-declarations.asp>
- _ Product specifications: <http://www.tridonic.com/com/en/product-specifications.asp>
- _ Other technical documents: <http://www.tridonic.com/com/en/technical-docs.asp>

Appendix

13.1. Commands for broadcast and luminaire groups

DALI command	Broadcast commands	Luminaire group commands
Light level (DAP)	Light level is called up => Lighting control is temporarily disabled (static operation)	Light level is called up => Lighting control is temporarily disabled (static operation)
OFF	off	off
UP	Can be set using masterCONFIGURATOR Factory setting: Dimming light level => Lighting control is temporarily disabled (static operation)	Can be set using masterCONFIGURATOR Factory setting: Dimming light level => Lighting control is temporarily disabled (static operation)
DOWN		
STEP UP	Dimming light level => Lighting control is temporarily disabled (static operation)	Dimming light level => Lighting control is temporarily disabled (static operation)
STEP DOWN	Dimming light level => Lighting control is temporarily disabled (static operation)	Dimming light level => Lighting control is temporarily disabled (static operation)
ON AND STEP UP	Dimming light level => Lighting control is temporarily disabled (static operation)	Dimming light level => Lighting control is temporarily disabled (static operation)
STEP DOWN AND OFF	Dimming light level => Lighting control is temporarily disabled (static operation)	Dimming light level => Lighting control is temporarily disabled (static operation)
RECALL MIN LEVEL	MIN LEVEL is called up => Lighting control is temporarily disabled (static operation)	MIN LEVEL is called up => Lighting control is temporarily disabled (static operation)
RECALL MAX LEVEL	Can be set using masterCONFIGURATOR Factory setting: MAX LEVEL is called up => Lighting control temporarily disabled (static operation)	Can be set using masterCONFIGURATOR Factory setting: MAX LEVEL is called up => Lighting control temporarily disabled (static operation)

Appendix

GO TO SCENE X	Can be set using masterCONFIGURATOR Factory setting: Calling up Scenes 0-14 => Lighting control temporarily disabled (static operation) Calling up Scene 15 => Lighting control is enabled (automatic operation)	Can be set using masterCONFIGURATOR Factory setting: Calling up Scenes 0-14 => Lighting control temporarily disabled (static operation) Calling up Scene 15 => Lighting control is enabled (automatic operation)
---------------	---	---

13.2. Commands to DALI address

The following table lists those commands that are supported by the DALI MSensor 02 and are sent to the DALI address. DALI commands to which the sensor reacts in a different way than specified in the DALI standard are explained.

Number	DALI command	Command to DALI address of MSensor 02
5	RECALL MAX LEVEL	Activation of identification
6	RECALL MIN LEVEL	Deactivation of identification
32	RESET	
33	STORE ACTUAL LEVEL IN THE DTR	
96 - 111	ADD TO GROUP	
112 -127	REMOVE FROM GROUP	
128	STORE DTR AS SHORT ADDRESS	
144	QUERY STATUS	Response is always "b00010000"
145	QUERY BALLAST	
149	QUERY RESET STATE	
150	QUERY MISSING SHORT ADDRESS	
151	QUERY VERSION NUMBER	
152	QUERY CONTENT DTR	
153	QUERY DEVICE TYPE	Response is "b11111110"
160	QUERY ACTUAL LEVEL	Query brightness value and status of motion sensor

Appendix

192	QUERY GROUPS 0-7
193	QUERY GROUPS 8-15
194	QUERY RANDOM ADDRESS (H)
195	QUERY RANDOM ADDRESS (M)
196	QUERY RANDOM ADDRESS (L)
256	TERMINATE
257	DATA TRANSFER REGISTER (DTR)
258	INITIALISE
259	RANDOMISE
260	COMPARE
261	WITHDRAW
264	SEARCHADDRH
265	SEARCHADDRM
266	SEARCHADDRL
267	PROGRAM SHORT ADDRESS
268	VERIFY SHORT ADDRESS
269	QUERY SHORT ADDRESS

13.2.1. Additional explanations

DALI "RECALL MAX LEVEL" and "RECALL MIN LEVEL" commands

When the "RECALL MAX LEVEL" command is sent to the DALI address of the DALI MSensor 02, its internal LED starts to flash. This makes it possible to identify the sensor in the system. The "Recall Min" function complements the "Recall Max" function. When this command is broadcast or sent to the address of the DALI MSensor 02, the LED is no longer lit.

DALI "QUERY ACTUAL LEVEL" command

This command can be used to query the currently measured brightness value and the status of presence detection. The MSensor 02 returns an 8-bit value.

This response is coded as follows:

Appendix

Binary response	Presence value	Light sensor value
MLLL'LLLL	M (bit 7): Presence status	LLL'LLLL (bits 6..0): Brightness
	1 = Motion detected 0 = No motion detected	Binary coded brightness

Brightness code LLL'LLLL (bits 0..6)	Binary representation of brightness in lx	Brightness values in lx
11xxxxx	1xxxxx0000	512...1008 lx, in 16 lx increments
10xxxxx	01xxxxx000	256...504 lx, in 8 lx increments
01xxxxx	001xxxxx00	128...252 lx, in 4 lx increments
00xxxxx	000xxxxx00	0...124 lx, in 4 lx increments

NOTICE

The brightness measured by the sensor depends on various factors such as room height, type of furniture and the nature of the floor. The value measured at the sensor is only 20 to 40% of the actual brightness across the measured surface area. Example: A brightness value of 500 lx on a desk having a reflectance of 30% produces a measured brightness value on the sensor of 150 lx. The motion sensor bit contains information indicating that motion has taken place since the last query, i.e. the bit is set in the event of motion and cleared again by the "QUERY ACTUAL LEVEL" query.