

basicDIM ILD G2 SFI 20 16DPI CR WH

Compact control module with ambient light sensor and motion sensor



Product description

- _ For up to 64 DALI drivers, expandable with DALI-2 Input Devices (see data sheet 3.1 Wiring)
- _ Designed for industrial, warehouse and retail applications, the PIR High-Bay CR 16m provides reliable motion detection at mounting heights of up to 16 meters
- _ Rectangular detection area is optimized for warehouse and corridor environments, ensuring precise coverage where it matters most
- _ High performance in corridor applications achieved using single PIR engine in combination with the special optic
- _ The innovative mechanical design allows the optics to be rotated by 90°, enabling optimal adjustment of the detection area orientation depending on customer use case and lighting fixture position
- _ Optional shutter accessories offer the flexibility to restrict detection zones, making it ideal for entry areas or narrow corridors
- _ The front housing is engineered for enhanced ingress protection, achieving an IP65 rating for superior durability in demanding conditions
- _ Integrated application controller
- _ Flexible configuration via companionSUITE
- _ 2 DALI groups with adjustable offset
- _ Monitoring of ambient light and motion detection
- _ Infrared remote control for configuration and operation
- _ Individual adjustment of the parameters
- _ Power supply via DALI line
- _ Mounting ring and gasket included to reach IP65 protection
- _ For luminaires of protection class II and III
- _ Built-in sensor with double insulation
- _ Double terminals for through wiring
- _ 5 years guarantee (Conditions at <https://www.tridonic.com/en/int/services/manufacturer-guarantee-conditions>)

Housing properties

- _ Casing: polycarbonate, white
- _ Type of protection up to IP65

Website

<http://www.tridonic.com/28005997>



basicDIM ILD G2 SFI 20 16DPI CR WH

Compact control module with ambient light sensor and motion sensor

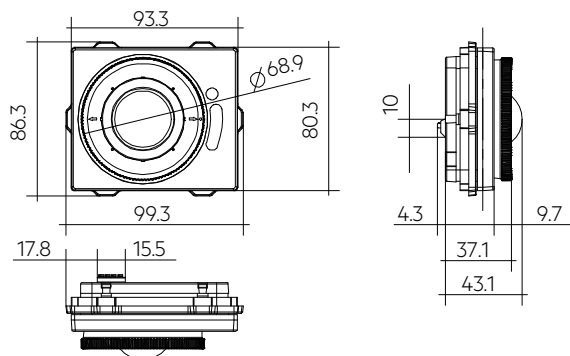

Ordering data

Type	Article number	Suitable for	Packaging, carton	Weight per pc.
basicDIM ILD G2 SFI 20 16DPI CR WH	28005997	Luminaire installation	10 pc(s).	0.114 kg

Technical data

Supply via	DALI cable
Supply voltage ^①	9.5 – 22.5 V
Current consumption (no LED)	max. 11 mA
Current consumption (with LED)	max. 12 mA
Mounting height	8 – 16 m
Mounting opening	70 x 83 mm
Housing thickness of the luminaire	0.75 – 4 mm
Detection angle for PIR detection angle "horizontal"	92°
Detection angle for PIR detection angle "vertical"	45°
Detection range for light measurement ^②	1 – 2,000 lx
Min. temperature difference between ambient temperature and detected object	± 4 °C
Ambient temperature ta	-20 ... +50 °C
tc point	60 °C
Storage temperature ts	-25 ... +60 °C
Dimensions L x W x H	99.3 x 86.3 x 47.4 mm
Housing material body	PC polycarbonate
Housing material lens	PE polyethylene
Housing colour body	White (similar to RAL 9016)
Housing colour lens	White
Type of installation	Fitted in luminaires
Type of protection ^③	Up to IP65
Guarantee (conditions at www.tridonic.com)	5 Year(s)

Approval marks



Standards

EN 61347-2-11, EN 61347-1, EN 61547, EN 55015, EN 62386-101, EN 62386-103, EN 62386-301, EN 62386-303, EN 62386-304

① 14 – 20.5 V if use PB11. Uin according to IEC 62386-101.

② The measured value at the sensor head corresponds to approx. 5 to 10,000 lux on the surface measured.

③ Depending on the installation type up to IP 65 for more details see data sheet.

REMOTECONTROL IR6

Accessory



Product description

- _ Optional infra-red remote control
- _ Switching on and off (On/Off button)
- _ Dimming (Up/Down button)
- _ Activation of automatic lighting control (Automatic button)
- _ Setting the threshold control point (Set button)
- _ IR range up to 20 m

Website

<http://www.tridonic.com/28000647>



Ordering data

Type	Article number	Dimensions L x W x H	Packaging, carton	Weight per pc.
REMOTECONTROL IR6	28000647	86.5 x 40.5 x 7.2 mm	500 pc(s).	0.019 kg

basicDIM ILD G2 Programmer

Accessory

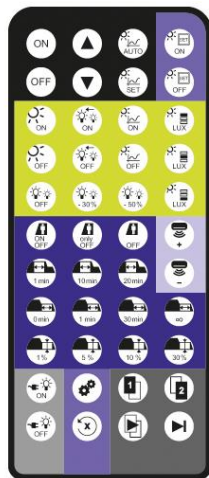

Product description

- _ Optional infra-red programming unit for basicDIM ILD G2
- _ Setting of predefined parameter values
- _ Programmable functions such as light level, time delay, P.I.R., bright-out, power up and grouping
- _ IR range up to 20 m

Website

<http://www.tridonic.com/28003484>

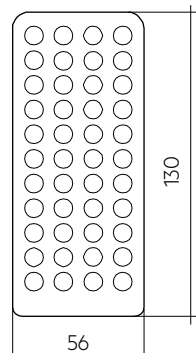

Ordering data

Type	Article number	Packaging, carton	Weight per pc.
basicDIM ILD G2 PROGRAMMER	28003484	150 pc(s).	0.04 kg

Approval marks



Shading Kit

Accessory

Product description

_ Two different shutters give the ability to reduce the detection area for Narrow and Entry applications



28005969



28005970

Website

<http://www.tridonic.com/28005969>



Ordering data

Type	Article number	Packaging, carton	Weight per pc.
Shading entry ACU 035 16DP CR	28005969	500 pc(s).	0.011 kg
Shading narrow ACU 036 16DP CR	28005970	500 pc(s).	0.013 kg

Mounting box 16DPI

Accessory



Product description

- _ Easy adaptation of suspended lighting fixtures to a sensor solution, just by adding one additional hole
- _ Side entry screw connection in combination with rubber gasket gives a true IP65 protection for industrial applications
- _ Easy remote commissioning with IR interface while sensor is still protected
- _ Tightening torque = 0.6 Nm

ACU MOUNTING BOX 16DPI HIGHBAY



Website

<http://www.tridonic.com/28001568>



ACU MOUNTING BOX 16DPI HIGHBAY with sensor

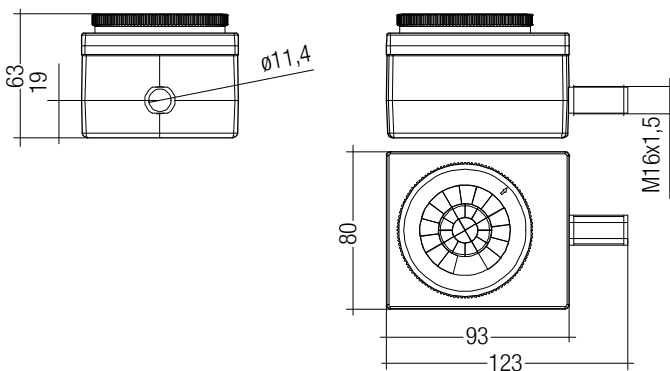

Ordering data

Type	Article number	Packaging, carton	Weight per pc.
ACU MOUNTING BOX 16DPI HIGHBAY	28001568	64 pc(s).	0.105 kg

Sensor housing ACU 033 IP65 WH

Accessory

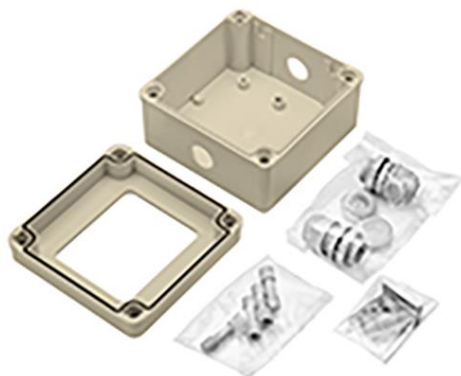
**Product description**

- _ IP65 protection box
- _ Mounting box for DALI MSensor G3 SFI 30 PIR 16DPI WH sensors allowing direct mounting to the ceiling
- _ Easy "Click In" installation of the sensor to the top part of the box
- _ Casing: ABS, white RAL 9010
- _ UV stabilized plastic
- _ Full mounting kit with screws and dowels, allowing hassle free mount of the box to the ceiling
- _ Including 2 cable glands and 2 grommets for ideal IP protection of inserted cables with a diameter of 6 – 12 mm
- _ Casing passed glow wire test with 850 °C according to EN 61347-1

Website

<http://www.tridonic.com/28003866>

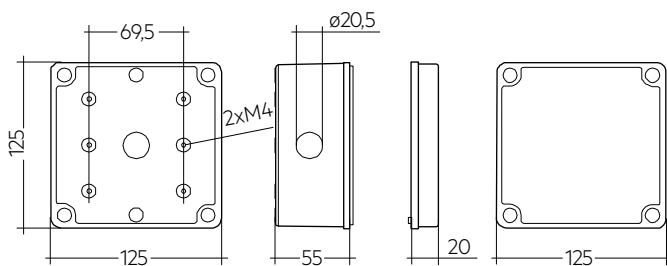
**Ordering data**

Type	Article number	Packaging, bag	Packaging, carton	Weight per pc.
Sensor housing ACU 033 IP65 WH	28003866	1 pc(s).	48 pc(s).	0.24 kg

basicDIM ILD G2 CWM 20 PBI1

Accessory

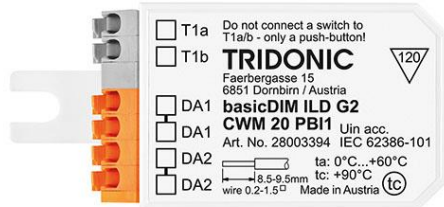

Product description

- _ Push Button Interface (PBI) for ILD G2 and ILD G2 FSL system
- _ Flexible configuration via the ILD G2 and ILD G2 FSL in combination with the companionSUITE
- _ Short push button action: automatic / fade off (factory default)
- _ Long push button action: dim up / dim down (factory default)
- _ Double push button action: set new target value for light regulation (factory default)
- _ Through-wiring DA1 / DA2 possible
- _ Detachable mounting flaps, allow installation in flush-mounted boxes and luminaires

Note

- _ A permanent short circuit between T1a and T1b results in limited function
- _ Only push buttons can be used

Website

<http://www.tridonic.com/28003394>

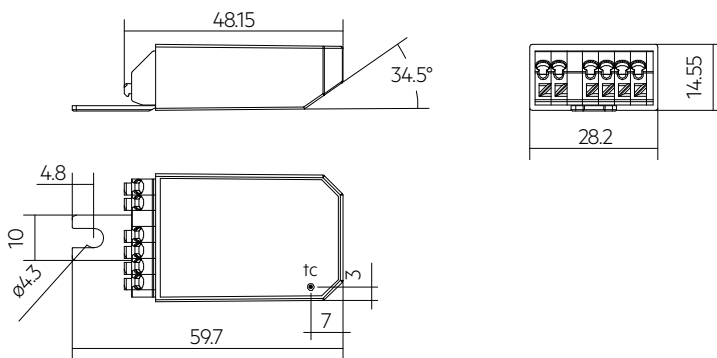

Ordering data

Type	Article number	Packaging, carton	Weight per pc.
basicDIM ILD G2 CWM 20 PBI1	28003394	15 pc(s).	0.012 kg

Approval marks



1. Standards

EN 61347-2-11
 EN 61347-1
 EN 61547
 EN 55015
 EN 62386-101
 EN 62386-103
 EN 62386-301
 EN 62386-303
 EN 62386-304

1.1 DALI standard

The basicDIM ILD is designed to control control gear with DALI standard IEC 60929 (DALI V0), IEC 62386 (DALI V1/DALI-2).

1.2 Glow wire test

according to EN 61347-2-11 passed for temperatures up to 850°C.

2. Common

The basicDIM ILD G2 provides the basis for an easy-to-use and cost-effective lighting system with motion detection.

When the sensor detects movement it triggers a individual adjustable motion detection profile in the control unit.

As the amount of natural ambient light changes the illuminance from the artificial lighting system is adjusted.

The connected luminaires can be switched on and off via momentary-action switch or remote control possible.

IR is always active.

This sensor provides measurement of ambient light, motion detection via PIR sensor and IR remote control input as well as a LED output for signalization.

basicDIM ILD G2 is created for following main applications:

For buildings with mid to high ceiling heights such as:

- Factory buildings
- Corridors, passages und Garages
- Storage buildings and warehouses



The basicDIM ILD G2 was developed and tested exclusively for Tridonic MSensor G3, XC G3 and PBI1. The use of other sensors and push button modules can lead to errors.

3. Installation

- DALI is not SELV.
The installation instructions for mains voltage therefore apply.
- The basicDIM ILD G2 is supplied directly via the DALI lines and must not be connected to the mains.
- The maximum cable length of the DALI control signal must not be exceeded.
- Please ensure that the detection range of the sensor lies in the lighting area of the controlled luminaires.
- Please ensure that the detection ranges of the sensors do not overlap. This may have influence to the lighting control.
- Heaters, fans, printers and copiers located in the detection zone may cause incorrect presence detection.
- Surface temperature is detected by the sensor.
Clothing or covers which reduce the surface temperature affect the detection.
- To avoid false readings, the sensor should be installed so there is no direct light from the lamp in the detection zone. Reflections can disturb the measurement results as well (e.g. high-bay warehouse of metal shelves).
- To avoid false measurements caused by the light from other luminaires we recommend that the sensor should be located centrally in the luminaire.
- The detection area is rectangular and can be rotated up to 90° by turning the ring, if this ring is rotated to often (>10x) the IP Protection may be impaired.
- Sensor must be installed according to the installation instructions to ensure the IP protection.
- Sensor head is not UV resistant.
- In case of pollution or mechanical damage of the lens, the functionality of the sensor may be limited.
- Avoid direct illumination of the light source on the sensor including housing.
- Additional IR sources can disturb the sensor.
- The maximum permissible current consumption of all components on the bus must not exceed the maximum permissible current of the connected DALI Power Supply.
- When using pre-addressed DALI components, double addressing may occur. This error can be corrected by pressing the reset button. Commissioning must be carried out again.
- Additional IR sources can interfere with the sensor.
- The maximum permissible current consumption of all components on the bus must not exceed the maximum permissible current of the connected DALI Power Supply.
- When using pre-addressed DALI components, double addressing may occur. This error can be corrected by pressing the reset button (basicDIM ILD G2 Programmer). The commissioning must be carried out again.

3.1 Wiring

Room application:

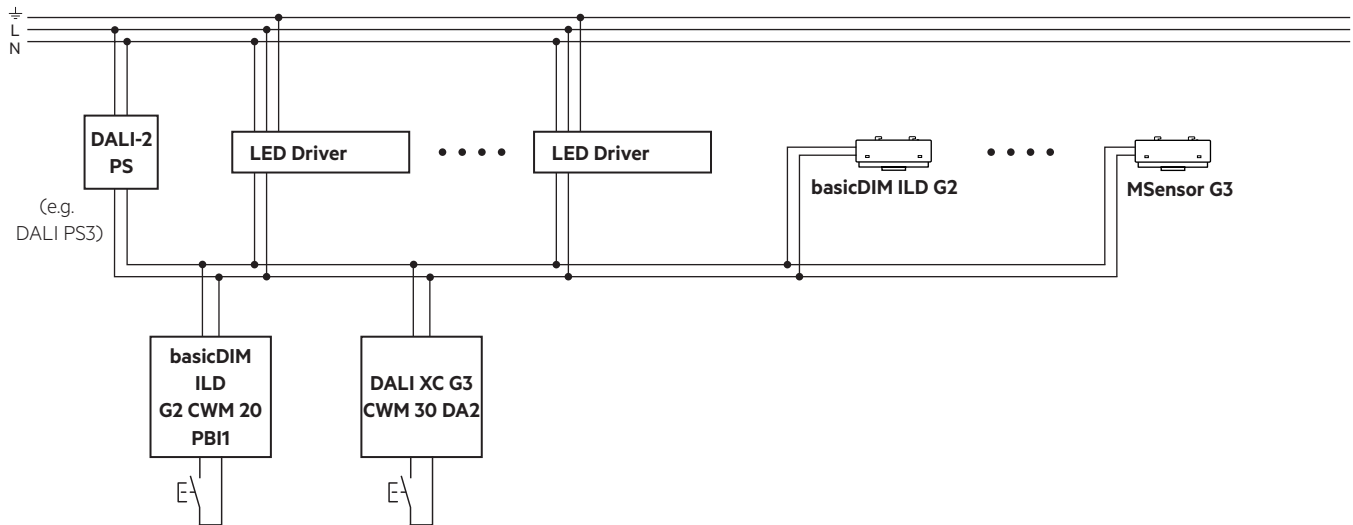

Through wiring:

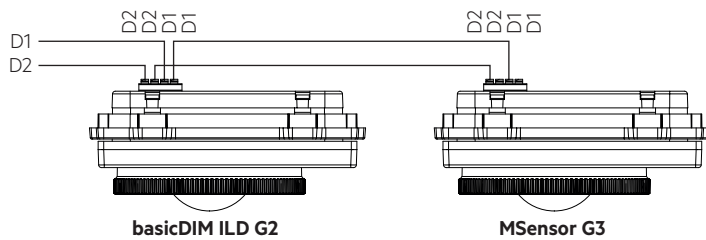

Maximum number of connected devices:

Devices	Number
ILD G2	1 pc.
DALI PS	2 pc. (max. 250 mA)
LED driver	64 pcs.
Input devices (MSensor G3, XC G3)	8 pcs.
PBI1	4 pcs.

DALI repeater must not be used.

Compatible accessories:

- MSensor G3 as additional, slave motion detector
- XC G3 as multi channel push button interface

Factory settings for DALI XC G3:

Button	Action	Factory settings
T1	Short press	Automatic / Fade off
	Long press	Dim up / Dim down
	Double click	SET (store new value for constant light control)
T2	Short press	Automatic
	Long press	not used
	Double click	not used
T3	Short press	not used
	Long press	Dim up / Dim down
	Double click	not used
T4	Short press	Automatic (switch luminaire on or change to automatic mode)
	Long press	not used
	Double click	SET (store new value for constant light control)

Factory settings for PBI1:

Button	Action	Factory settings
T1	Short press	Automatic / Fade off
	Long press	Dim up / Dim down
	Double click	SET (store new value for constant light control)

3.2 Cable types and cable cross-sections

For wiring use solid wire from 0.2 to 1.5 mm².

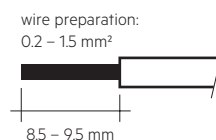

3.3 Mounting variant luminaire housing:

Sheet thickness: 1 – 4 mm

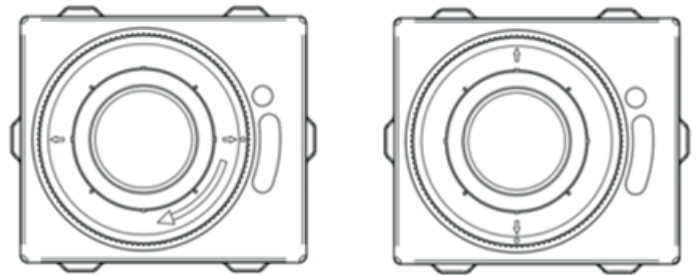
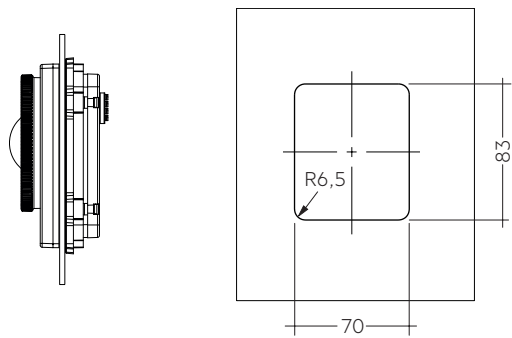

The detection area is rectangular and can be rotated up to 90° by turning the ring. The arrow on the ring points in the length of the detection area.

3.4 Sensor mounting

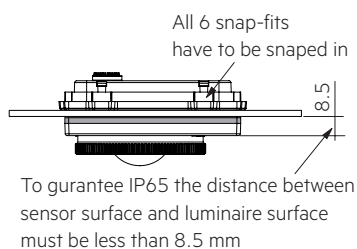
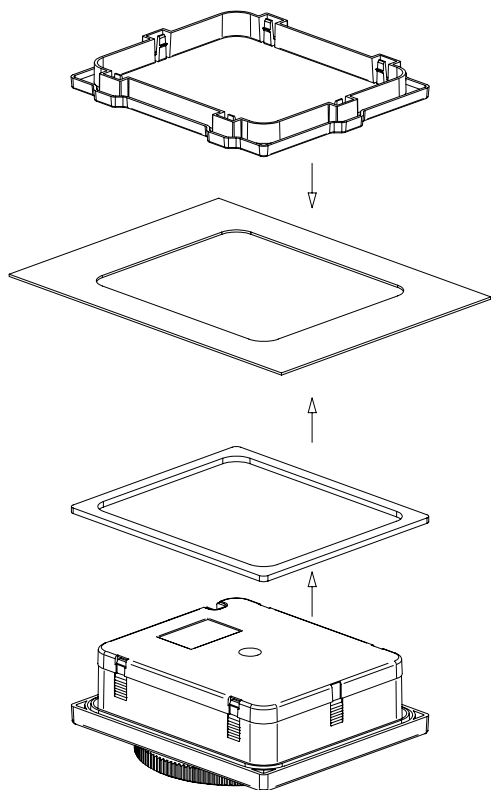

3.5 Shader mounting

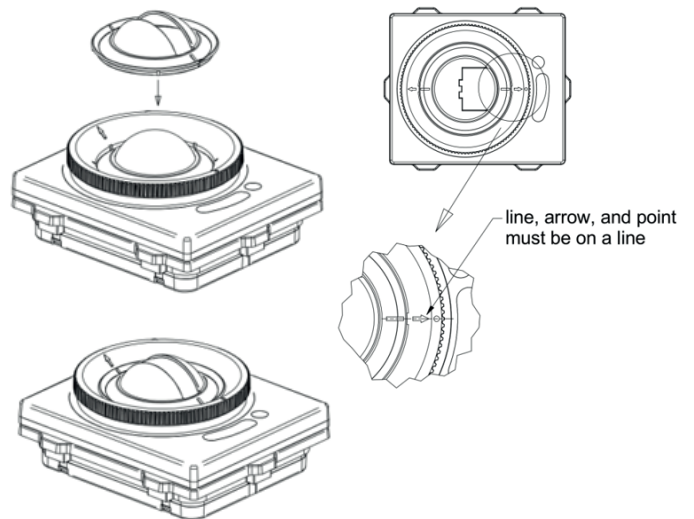

3.6 Ingress protection

This device contains IP-protection to use it also in applications with the need of protection against dust and water ingress. IP65 protection applies to the front of the sensor whereas the back of the sensor is IP20 rated.

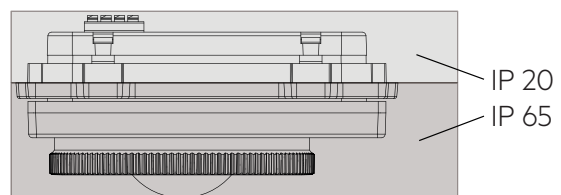

3.7 Mounting box mounting



- The sensor can be installed only once in the mounting box (Sensor snap in permanent)!
- Insert the cable of the sensor before installing.
- There are 2 installation variants possible for the sensor. The sensor can be turned through 180°.

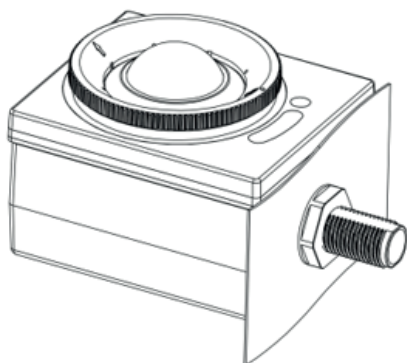
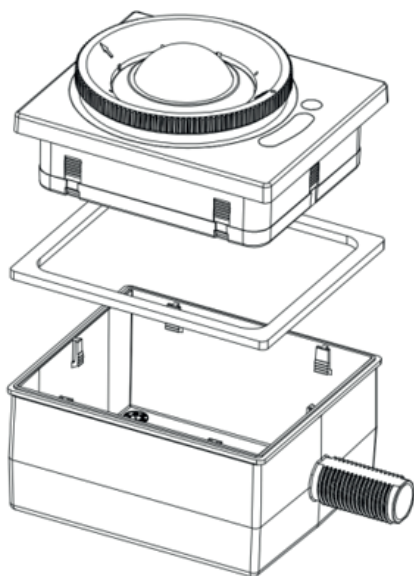

3.9 Mounting in class II luminaire

The Sensor provides basic insulation as required by IEC 62386-101 and defined in IEC 61347-1.

If the sensor is built in to a class II luminaire which has to provide double or reinforced insulation it has to be considered that the Sensor is not a class II device. Still the Sensor can be used for such projects as the most part of the sensor is tested to fulfil the class II requirements for double or reinforced insulation. Basic insulation is illustrated in the graphic below and covers an area 2,5 mm around the terminal.

The rest of the sensor fulfils class II requirements.

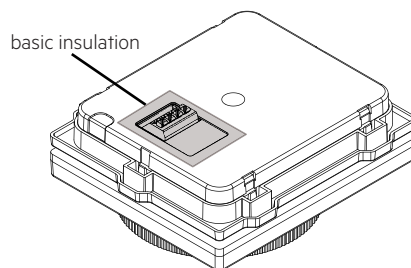

3.8 Mounting box in luminaire housing:

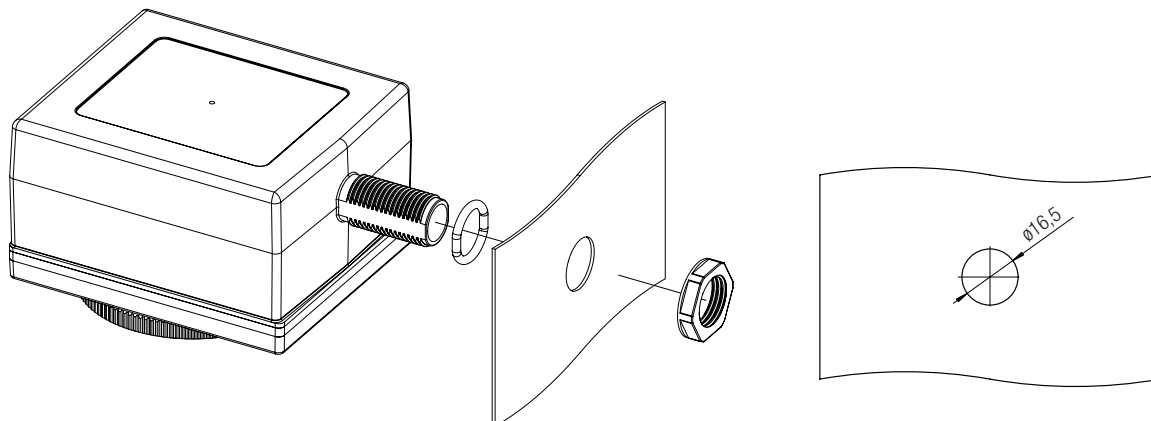

4. Sensor functions

4.1 Light level recognition area

The light measurement has a cone-shaped detection area with a half angle of approximately 6.5°.

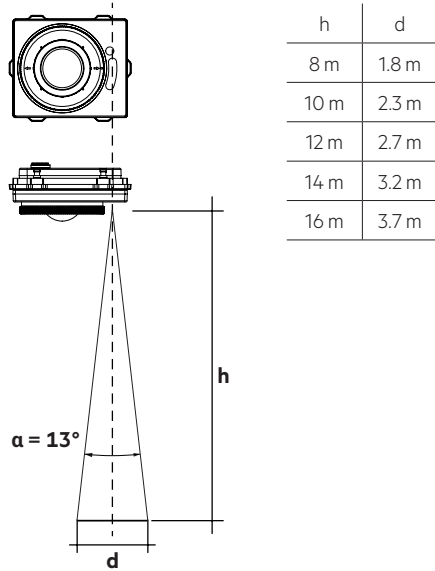

The measurement range is between 1 and 2,000 lx. Measured at the sensor head.

4.2 Detection area

The detection range is rectangular, with a length a oriented at horizontal angle H and a width b oriented at vertical angle V at floor level. Graphic shows the default position.

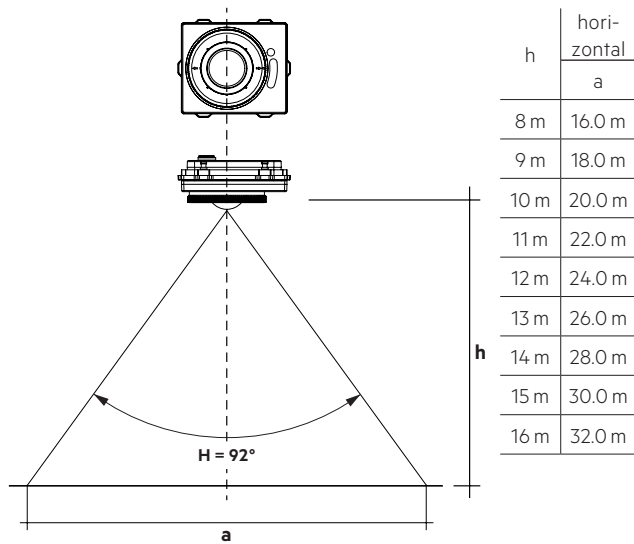

4.3 Status LED's

The status LED is deactivated by default. There is a LED built in to indicate different status information to the user. This LED is controlled from the sensor itself.

! To not have any influence from LED to the light measurement, LED is disabled while light sensor is measuring by default.

Status	Pattern	Incident
-	-	Normal operation
Single red flash	0.2 s on. all 6 s	Motion has been detected
Permanent red flashing	0.2 s on. all 1 s	System error: - Second basicDIM ILD G2 available - Stuck button time out
Long green flashing	1 s on. all 6 s	Bright-out active
Orange flashing	0.5 s on. all 0.5 s	Start-up, Grouping, Test mode, Reset active application controller deactivated
Short blue flashing	0.2 s	Receive infrared command from basicDIM ILD G2 Programmer or IR6

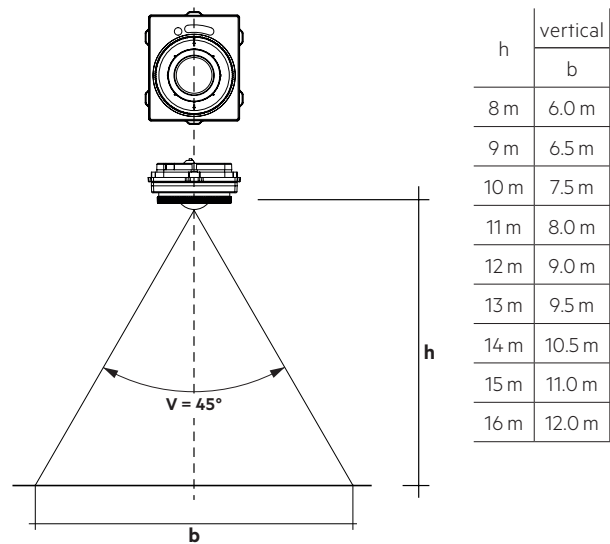

4.4 Presence / motion detection with shader

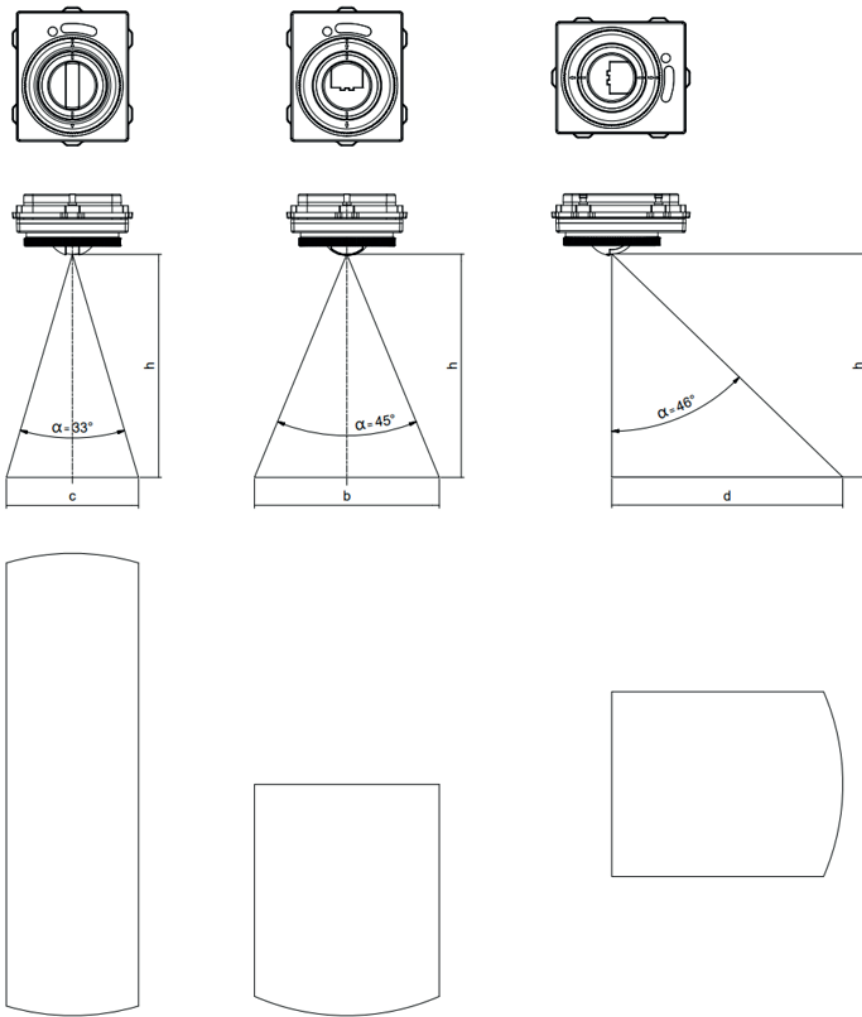

4.5 Application

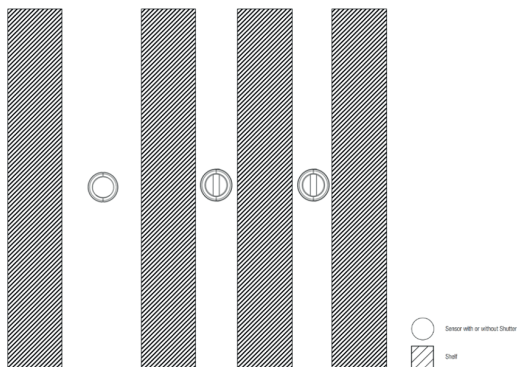
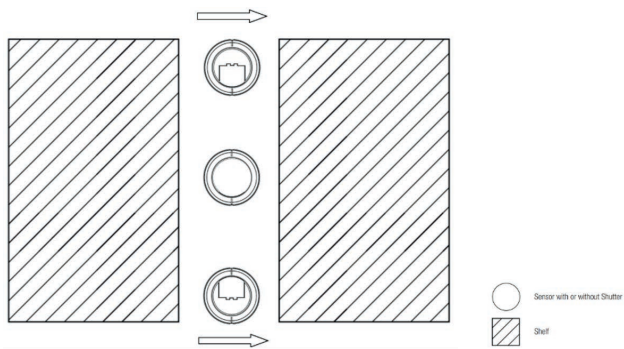

4.6 User-definable parameters

Parameter	Range (Factory Settings)	Description
power-up behavior	on / off (on)	If the parameter is set to "on", the luminaire switches on after a mains break. If the parameter is set to "off", the luminaire does not switch on after a mains break.
Presence lux level	Absence level / 1000 lux (500 lux)	Value used by the light sensor to regulate the presence level of the luminaire. On account of the room conditions and the installation height, the illuminance in the workspace may, however, be three to four times higher.
presence level	1 to 100 % (100 %)	Brightness value that the ILD G2 occupies as soon as presence has been detected.
absence level	1 to 100 % (1 %)	Brightness value that the ILD G2 occupies while the switch-off delay is running.
fade-in time	0 to 15 (1)	Period of time starting as soon as presence is detected. During fade-in time, the luminous intensity fades to the presence value. 1 = 0.7 s 2 = 1 s 3 = 1.4 s 4 = 2 s 5 = 2.8 s 6 = 4 s 7 = 5.7 s 8 = 8 s 9 = 11.3 s 10 = 16 s 11 = 22.6 s 12 = 32 s 13 = 45.3 s 14 = 64 s 15 = 90.5 s
fade time	0 to 15 (8)	Period of time during which the luminous intensity fades from the presence value to the absence value. 1 = 0.7 s 2 = 1 s 3 = 1.4 s 4 = 2 s 5 = 2.8 s 6 = 4 s 7 = 5.7 s 8 = 8 s 9 = 11.3 s 10 = 16 s 11 = 22.6 s 12 = 32 s 13 = 45.3 s 14 = 64 s 15 = 90.5 s
run-on time	15 s to 60 min (20 min)	Time that begins to run from the last moment that presence was detected. After the run-on time the fade-off time is started. If another presence is detected in the room during run-on time, the run-on time is started again.
switch-off delay	off / 15 s to 60 min / never OFF (off)	Time in which the absence value is held. After expiration, the luminaire is either switched off or the absence value is held (never OFF).
fade-off time	0 to 15 (2)	Period of time starting after the run-on time. During the fade-off time, the luminous intensity fades to off. 1 = 0.7 s 2 = 1 s 3 = 1.4 s 4 = 2 s 5 = 2.8 s 6 = 4 s 7 = 5.7 s 8 = 8 s 9 = 11.3 s 10 = 16 s 11 = 22.6 s 12 = 32 s 13 = 45.3 s 14 = 64 s 15 = 90.5 s
constant light control	on / off (on)	Enables or disables the constant light control
bright-out	on / off (on)	If the parameter is set to "on", the luminaire switches off as soon as the light level exceeds the bright-out threshold of the set point for longer than 10 minutes. This could be the case if, for instance, the room is adequately illuminated by sunlight. If the bright-out threshold falls below 100 % of the set point, the luminaire switches back on again.
bright-out threshold	110 to 400 % (150 %)	Bright-out threshold used by the bright-out function
bright-out-off delay time	0 to 3,600 s (600 s)	Period of time that the light level must exceed the bright-out threshold to activate bright-out.
group 2 offset mode	fixed / converging (converging)	This parameter specifies how the group 2 offset value behaves if the light is dimmed up. If the parameter is set to "converging", the dimming level of group 2 will keep on rising even if group 1 has already reached a dimming level of 100 %. The brightness difference will be gradually reduced up to the point where both group 1 and group 2 reach the same dimming level of 100 % which effectively reduces the group 2 offset value to zero. This way, the offset will "converge". If the parameter is set to "fixed", the offset is "fixed". The brightness difference between group 1 and group 2 will stay at the value defined for the group 2 offset value. If the group 2 offset value was set to e.g. 30 %, the group 2 dimming level will always stay 30 % below the dimming level of group 1. If group 1 has reached a dimming level of 100 %, the dimming level of group 2 will stop rising because otherwise the offset would be reduced to less than the defined group 2 offset value.
group 2 offset value	0 to 95 % (30 %)	Adjustable brightness difference between group 2 and group 1

4.7 Possible push button configuration

Short Press	Long Press	Double Press
Automatic mode	Dimming up	Set target value
Recall max. level	Dimming down	No function
Off	Dimming up / dimming down	
Recall max. level / off	No function	
On with fade		
Off with fade		
Automatic mode / off with fade		
No function		

5. Miscellaneous

5.1 Disposal of equipment



Return old devices in accordance with the WEEE directive to suitable recycling facilities.

5.2 Additional information

Additional technical information at www.tridonic.com → Technical Data

Guarantee conditions at www.tridonic.com → Services

Lifetime declarations are informative and represent no warranty claim.
No warranty if device was opened.