

adaptiveSWARM CFI 30 IR DA2

SWARM Module for indoor use

**Product description**

- _ Plug and play – out of the box SWARM behavior in combination with the ILD G2 FSL
- _ Instant increase of comfort in the office
- _ IR communication – no mesh network needed to establish SWARM communication between neighbor luminaires
- _ Flexible and adaptive lighting fixture positioning
- _ Based on standards: DALI-2 certified input device
- _ Easy snap in installation, supporting Zhaga Book 20
- _ Easy possibility for upgrade and refurbishment in the field
- _ In combination with ILD G2 FSL the behavior of the sensor is adjustable via companionSUITE and therefore the ideal upgrade for free standing luminaires
- _ 5 years guarantee (conditions at www.tridonic.com)

Benefits

- _ adaptiveSWARM module sends out IR-signals, which are reflected by the ceiling and received by the neighbour luminaire. No mesh network needed to establish SWARM communication between neighbour luminaires.
- _ The adaptiveSWARM module is mounted on the luminaire and the special SWARM control profile is automatically active in conjunction with the ILD G2 FSL.
- _ No additional commissioning required. To disable the SWARM profile in the field, the IR Programmer remote control (in combination with ILD G2) is required.

Typical applications

- _ Mainly for use in offices with floor-standing luminaires in combination with IR SWARM technology. Can be used in combination with other luminaire types e. g. suspended fixtures depending on application.

Note

- _ Tridonic adaptiveSWARM CFI 30 IR DA2 is developed according to DALI Standard EN 62386-101 Ed.2, also known as DALI-2. To be able to use the sensor in such installation, an application controller is necessary.
- _ A list of approved application controller can be found on Tridonic WEB page in "Downloads" in document "Application controllers supporting the adaptiveSWARM CFI 30 IR DA2.pdf".

Website

<http://www.tridonic.com/28004302>



adaptiveSWARM CFI 30 IR DA2

SWARM Module for indoor use

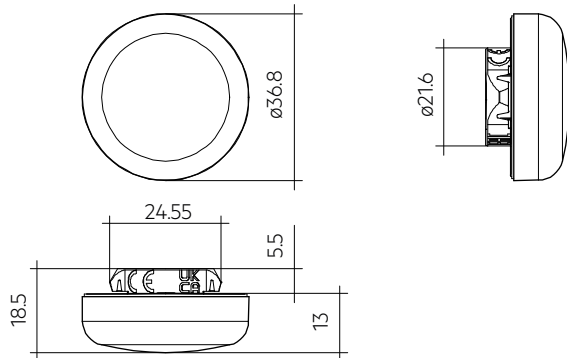
**Ordering data**

Type	Article number	Packaging, carton	Weight per pc.
adaptiveSWARM CFI 30 IR DA2	28004302	18 pc(s).	0.01 kg

Technical data

Sensor type	SWARM module
Supply via	DALI
Supply voltage ^①	12 – 22.5 V
Current draw	max. 18 mA
Wire length for DALI and power supply ^②	≤ 3 m
Starting time	≤ 1.2 s
Supported operating modes	0
Mounting hole	acc. to Zhaga Book 20
Type of installation	snaps into place
Max. radio range ^③	7.5 m
Ambient temperature ta ^④	0 ... +50 °C
tc point	60 °C
Storage temperature ts	-25 ... +60 °C
Dimensions Ø x H	Ø 36.8 x 18.4 mm
Housing material body	PC & Polyamid
Housing colour body	Black
Type of protection	IP20
Guarantee	5 Year(s)

Approval marks**Standards**

EN 61347-1, EN 61347-2-11, EN 55015, EN 61547, EN 62386-101 (DALI-2), EN 62386-103, EN 62386-303, EN 62386-351

① Uin acc. IEC 62386-101.

② For details see chapter wiring in data sheet.

③ Distance SWARM to ceiling 2.5 m.

④ Correct sensor operation can not be guaranteed if operated outside this ta window.

1. Standards

EN/IEC 61347-1
 EN/IEC 61347-2-11
 EN 55015
 EN 61547
 EN 62386-101 Ed.2
 EN 62386-103 Ed.1
 EN 62386-303
 EN 62386-351

1.1 DALI note



Device only applicable for installations with Tridonic Application Controllers that support the swarm function.

This device does not support identification by means of an LED, buzzer or other emitter.

Only 1 device per DALI bus is permitted.

List of approved application controller can be found on Tridonic WEB page in "Downloads" in document "Application controllers supporting the adaptiveSWARM CFI 30 IR DA2.pdf".

1.2 D4i note

D4i luminaire-mounted control devices (part 351) = Type B

1.3 Glow wire test

according to EN 61347-1 passed with 850 °C.

2. Common

The SWARM module is mounted on the top of a free-standing luminaire. It sends out IR signals that are reflected from the ceiling and received by the neighbouring luminaire. The neighbouring luminaires also need a SWARM module. The SWARM module is a DALI-2 device and is designed for operation in a system with a DALI-application-controller.

List of approved application controller can be found on Tridonic WEB page in "Downloads" in document "Application controllers supporting the adaptiveSWARM CFI 30 IR DA2.pdf".

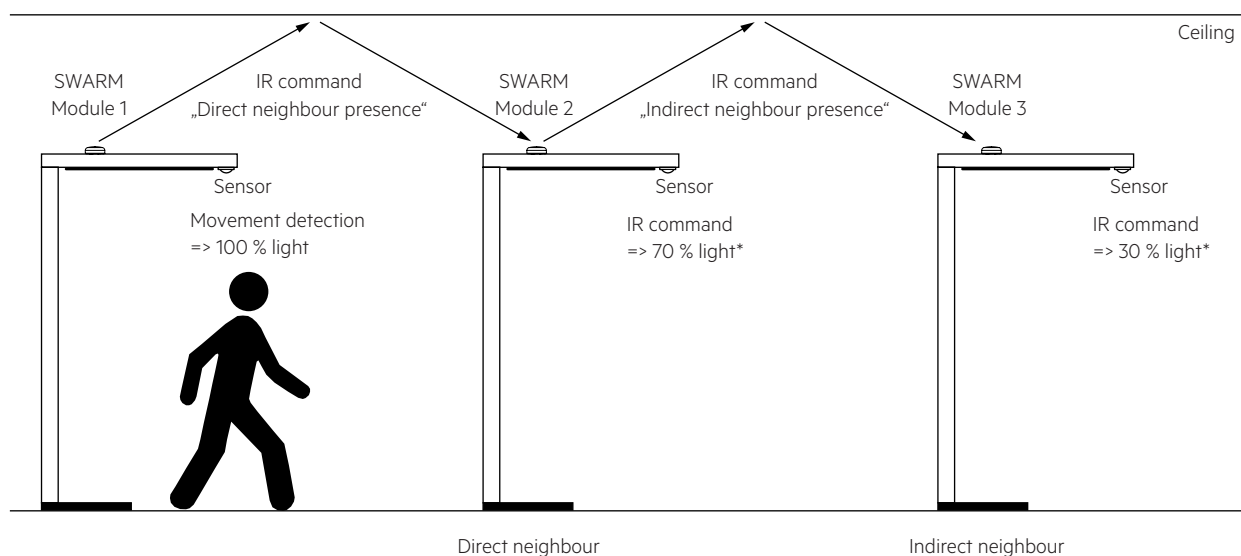

* Depending on the application controller used and the programming performed.

Do not obstruct the SWARM module's field of view to ensure reliable infrared communication.

To keep this area clear, observe the following rules:

The clearance is defined as a funnel in the centre of the unit starting at the height of the luminaire cover where the SWARM module is mounted.

The opening angle of this funnel is 150°.

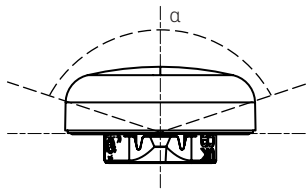

The SWARM module provides wireless communication via infrared.

This does not require any commissioning by the user.

The usable distance of this connection results from the physical properties of the module and the mounting location.

The achievable distance results from the angle of the transmitting LED and the receiving angle of the IR receiver. Other factors for the distance result from the installation, e.g. the reflection factor of the ceiling.

The figures below reflect the transmitting distances under normal conditions, which corresponds to the reflectivity of a white ceiling and no obstructions on the ceiling.

Depending on the conditions in the installation, the distances given below may vary.

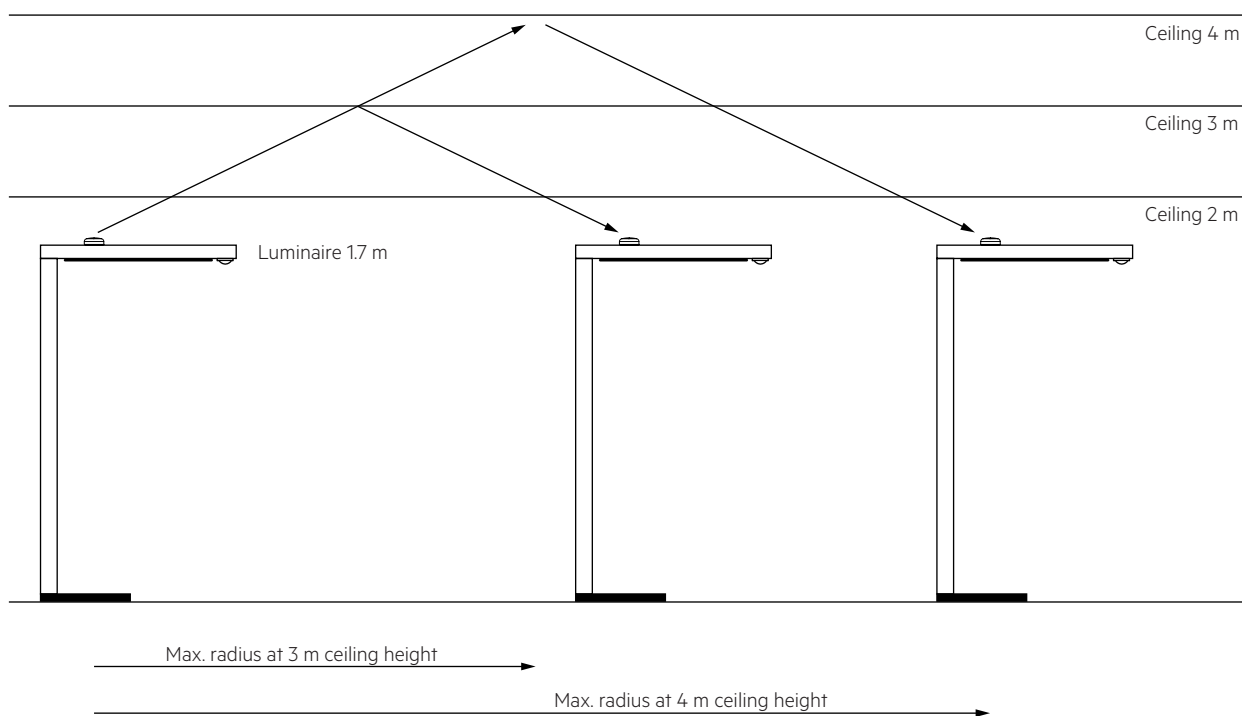

Distance SWARM to ceiling	Transmission radius
0.5 m	5.5 m
1.0 m	6.0 m
1.5 m	6.5 m
2.0 m	7.0 m
2.5 m	7.5 m

3. Installation

- The device must not be connected to mains. It is supplied directly via the DALI power supply.
- Make sure the used Power supply provides enough energy to power the device.
- DALI is not SELV. The installation instructions for mains voltage therefore apply.
- Correct device operation can not be guaranteed if operated outside his ta window.
- Make sure the sensor is mounted correctly and locked in place.
- The correct distance between the ceiling and the device must be taken into account during installation. Too small or too large distance will cause the device not to work as expected.
- The ceiling must be horizontal. Surfaces with a deviating alignment can influence the function of the device.
- The ceiling must be free of objects such as ventilation pipes or similar. Objects on the ceiling can influence the function of the device.
- The ceiling must ensure the best possible reflection of the IR radiation. A diffuse surface in white color is ideal.
- To avoid impairing the field of view of the device, no parts of the luminaire may be mounted within its field of view.
- If the lens is covered by dirt or other contaminants, the device may not function properly. Make sure that the housing is cleaned at regular intervals.
- To avoid scratches on the housing, do not use abrasive or aggressive cleaning agents for cleaning.
- The use of other IR light sources in the range of 800 to 1000 nm, especially permanent emitters should be avoided for the correct function of the device.
- Other devices that use infrared light for communication, such as remote controls of TV sets or similar, may be affected by the communication of the device.
- The device must not be rotated when installed to avoid damage to the connecting wires.

3.2 Wiring type and cross section

For wiring use stranded wire with ferrules from 0.2 to 0.5 mm² or solid wire from 0.14 to 0.5 mm².

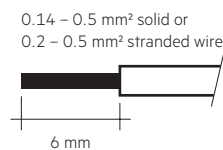

If the luminaire is designed according to Zhaga Book 20, then the accessory ACU 034 Z20 LEX-MR 150mm can be used.

3.1 Wiring

Following illustration visualizes the wiring of the components inside the luminaire.

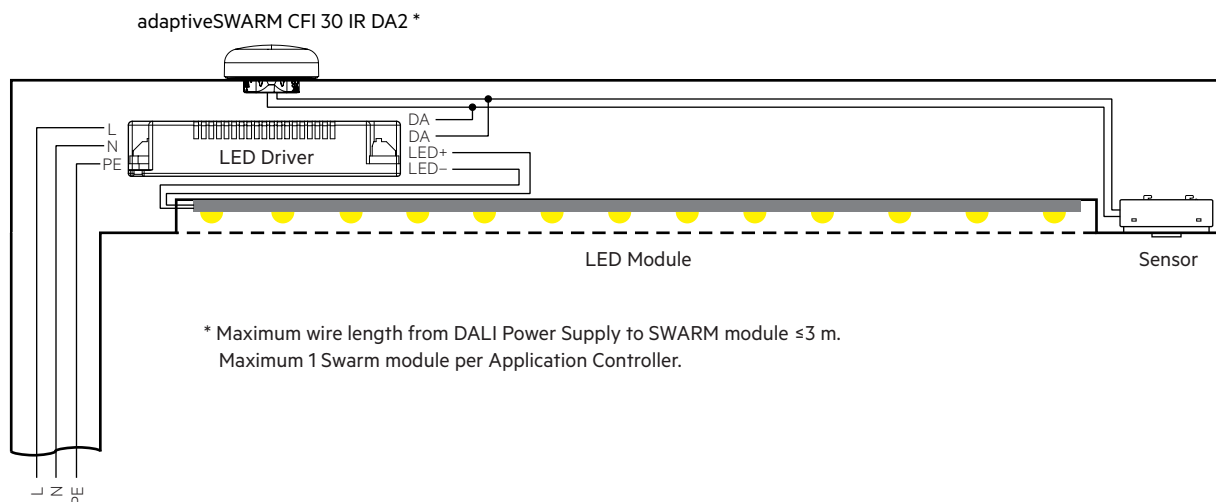

3.3 Mounting instructions

Mounting Hole:

The mounting hole of the luminaire must be prepared like defined in Zhaga Book 20 and have LEX-S dimensions.

The thickness of the mounting plate shall be in the range $0.4 \leq D \leq 1.5$ mm and the typical value is 0.7 mm.

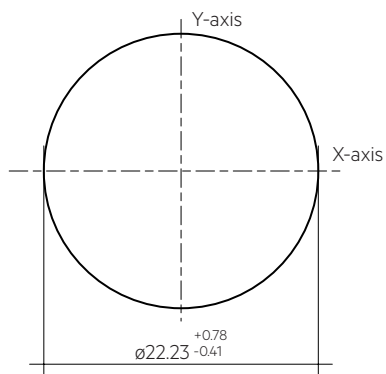

Mounting hole surrounding area:

The surrounding area of the mounting hole as indicated in grey in figure below shall have an even surface at the exterior of the Luminaire as well as at the interior of the Luminaire.

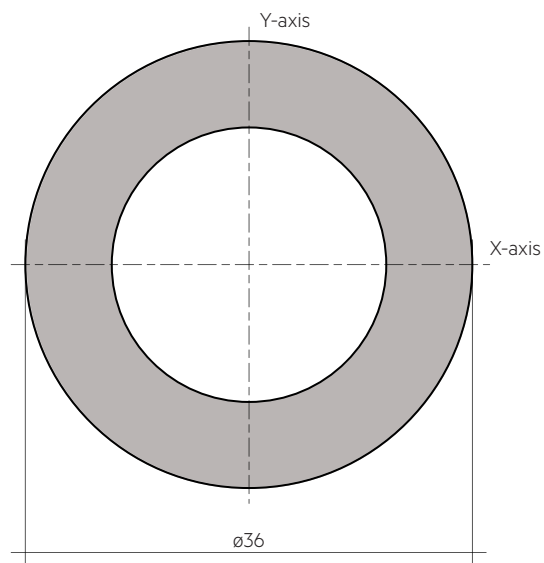

Installation on luminaire:

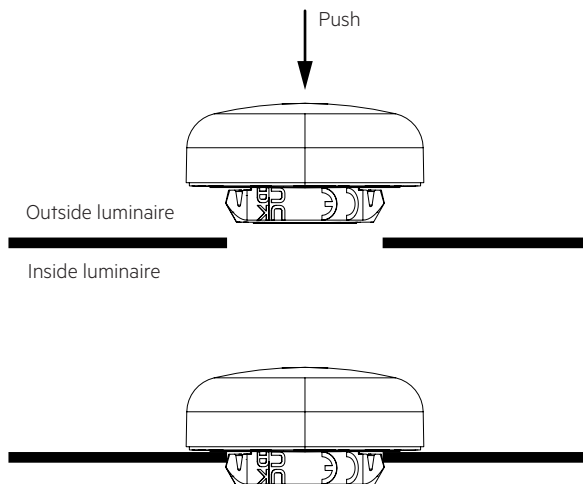

The device must lock in place.

If the lens is covered by dirt or other pollution the device may not be able to work sufficient, make sure the lens is cleaned in a regular interval.

4. Miscellaneous

4.1 Disposal of equipment



Return old devices in accordance with the WEEE directive to suitable recycling facilities.

4.2 Additional information

Additional technical information at www.tridonic.com → Technical Data

Guarantee conditions at www.tridonic.com → Services

Lifetime declarations are informative and represent no warranty claim. No warranty if device was opened.