

Wall mounting box

General



Product description

- _ Wall mounting box for the sceneCOM evo Touchpanel
- _ Suitable for flush-fitting, cavity and concrete installation
- _ IP30

Website

<http://www.tridonic.com/28005695>



Wall mounting box

General

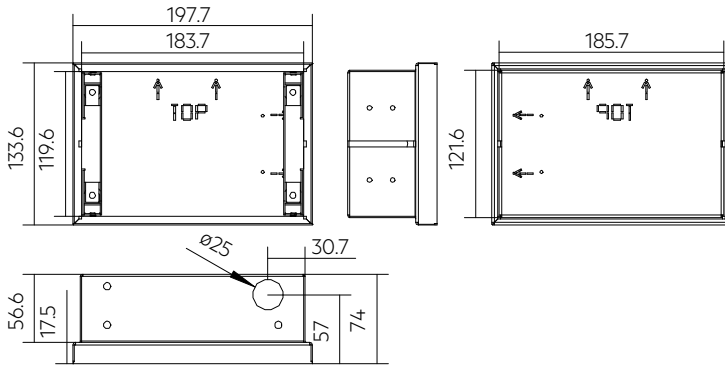

Ordering data

Type	Article number	Dimensions L x W x H	Packaging	Weight per pc.
sceneCOM evo WMB-Touchpanel	28005695	197.7 x 133.6 x 74 mm	1 pc(s).	0.788 kg