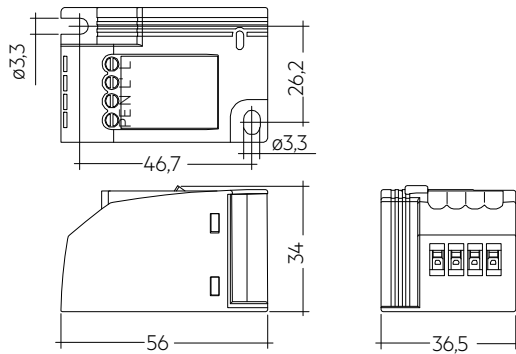

SPD 10kV PC1 CE SNC

Surge protection

**Ordering data**

Type	Article number	Packaging, carton	Packaging, pallet	Weight per pc.
SPD 10kV PC1 CE SNC	28003023	10 pc(s).	5,040 pc(s).	0.038 kg

Technical data

Rated supply voltage	100 – 277 V
AC voltage range	100 – 320 V
Mains frequency	50 / 60 Hz
Mode of protection	L-N, L-PE, N-PE
AC system	TN-C-S, TN-S, TT
Type 2 surge protection (T2)	Yes
Type 3 surge protection (T3)	Yes
Rated load current	16 A
Nominal discharge current (8/20 µs), L-N, L-PE, N-PE	5 kA, 5 kA, 10 kA
Max. discharge current (8/20 µs), L-N, L-PE, N-PE	10 kA, 10 kA, 20 kA
Combination wave (1.2/50 µs), L-N, L-PE, N-PE	10 kV (5 kA), 10 kA, 20 kA
Short-circuit current rating	3 kA
Voltage protection level (at nom. discharge I (8/20 µs) + at 6 kV (1.2/50 µs)), L-N, L-PE, N-PE	≤ 1.3 kV, 1.5 kV, 1.4 kV
Residual voltage (at nominal discharge I (8/20 µs) + at comb. wave (1.2/50 µs)), L-N, L-PE, N-PE	≤ 1.3 kV, 1.5 kV, 1.4 kV
TOV behavior (5 s / withstand mode)	400 V AC
TOV behavior (120 min. / safe failure mode)	528 V AC
Response time L-N, N-PE	≤ 25 ns, ≤ 100 ns
Max. backup fuse ^①	16 A
Ambient temperature t _a	-40 ... +80 °C
Storage temperature t _s	-40 ... +80 °C
Type of protection	IP20
Altitude (above sea level)	≤ 2,000 m
Dimensions L x W x H	56 x 36.5 x 34 mm

Approval marks

Standards

EN 61643-11

① MCB type B and C.

1. Standards

EN 61643-11

1.1 Glow-wire test

according to EN 61643-11 with increased temperature of 850 °C passed.

2. Guarantee conditions

5-year guarantee of the product.

Surge capability: 10 x 10 kV Combination Wave pulses (1.2 / 50 μs).

3. Installation / wiring

3.1 Circuit diagrams

Through wiring:

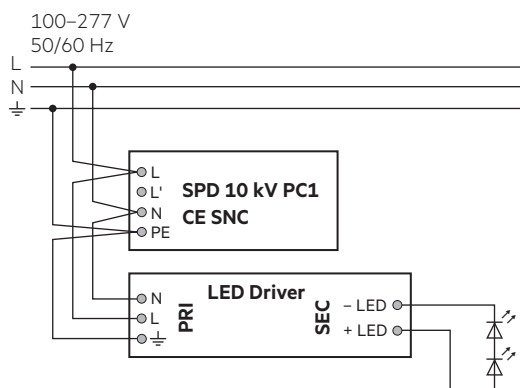

Through wiring with connection of L':

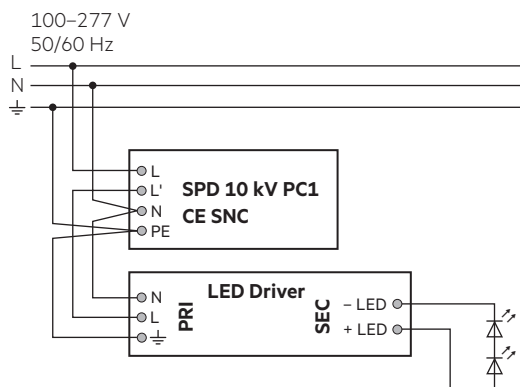

Branch wiring:

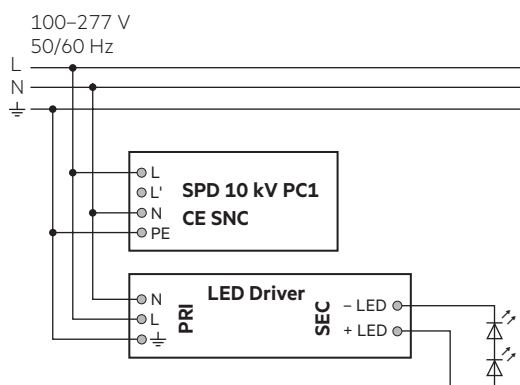

Single-branch wiring with connection of L':

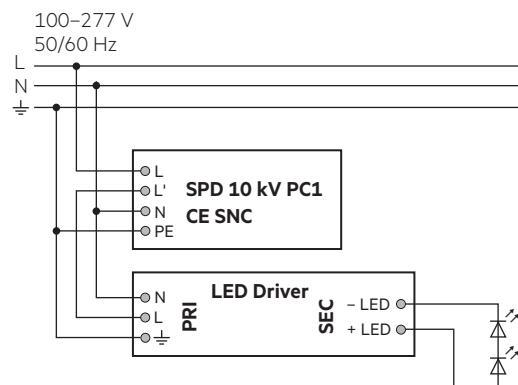

3.2 Wiring type and cross section

Screw thread	M3
Tightening torque	0.6 Nm
2 conductors with same cross section, stranded	0.2 – 1.5 mm ²
Conductor cross section, flexible	0.2 – 2.5 mm ²
2 conductors with same cross section, solid	0.2 – 1.5 mm ²
Conductor cross section, solid	0.2 – 4.0 mm ²

4. Functions

4.1 Status indicator

Indicator window turn red and AC network cut-off.

If the red indicator lights up, the device is damaged and must be replaced by appropriately qualified expert personnel.

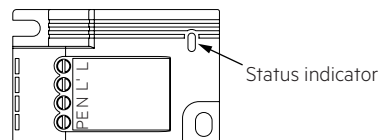

4.2 Fault message

Optical surge protection fault message.

5. Miscellaneous

5.1 Insulation testing

It is not necessary to disconnect the arrester during insulating strength measurement in electrical systems with 250 V because the measurements remain unaffected by the device.

5.2 Conditions of use and storage

Humidity: 5% up to max. 95%, not condensed

Storage temperature: -40 °C up to max. +80 °C

5.3 Additional information

Additional technical information at www.tridonic.com → Technical Data

Guarantee conditions at www.tridonic.com → Services

Lifetime declarations are informative and represent no warranty claim. No warranty if device was opened.