

**Module SLE G7 PW EXC**

Modules SLE excite



LES13 + LES15 with housing



LES17 with housing



LES13

**Product description**

- \_ For spotlights and downlights
- \_ For operating with SELV Driver
- \_ Excellent thermal management by COB technology
- \_ Uniform radiation with Dam&Fill technology
- \_ Integrated LED module
- \_ Cooling required
- \_ Flexible operating mode
- \_ HE ... High Efficiency, NM ... Nominal Mode, HO ... High Output
- \_ Long lifetime: 55,000 hours
- \_ 5 years guarantee (conditions at <https://www.tridonic.com/en/int/services/manufacturer-guarantee-conditions>)

**Optical properties**

- \_ Colour temperatures 3,000 and 4,000 K
- \_ Useful luminous flux 5,050 lm at Irated and tp = 25 °C
- \_ Efficacy of the LED module 138 lm/W at Irated and tp = 25 °C
- \_ High colour rendering index CRI > 90
- \_ Small colour tolerance (MacAdam 3)

**Mechanical properties**

- \_ Module dimension LES13, LES15 and LES17
- \_ Housing with Snap-On feature for easy reflector mounting
- \_ 50 mm housing with 35 mm mounting hole distance acc. to Zhaga
- \_ Fixing holes for M3 screws

**System solution**

- \_ Integrate compatible partner products into your final system solution: <https://www.tridonic.com/en/int/products/accessories#partner>
- \_ Combine Tridonic's LED modules and dimmable drivers to achieve an outstanding system efficacy (configuration possible via <https://setbuilder.tridonic.com/>)

**Website**

<http://www.tridonic.com/28002704>

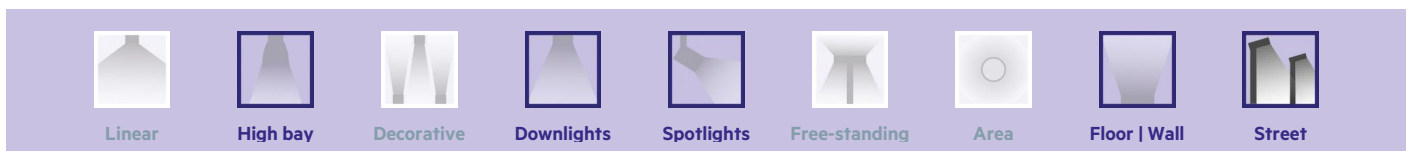
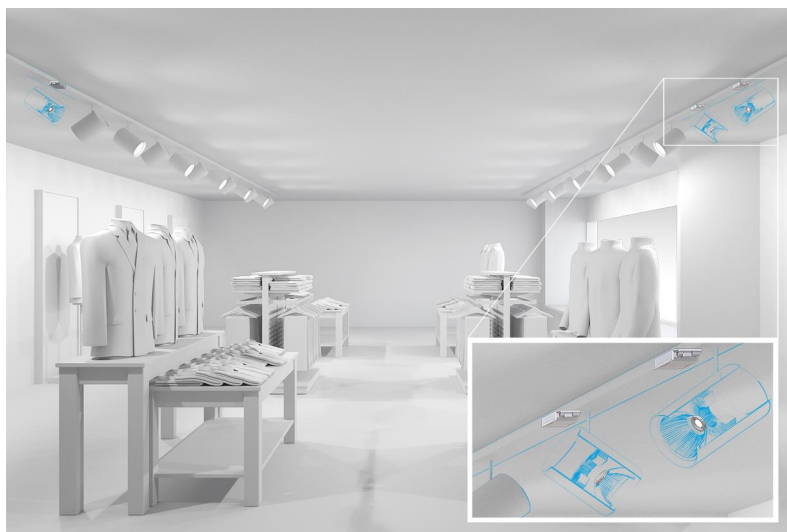

**Module SLE G7 PW EXC**

Modules SLE excite

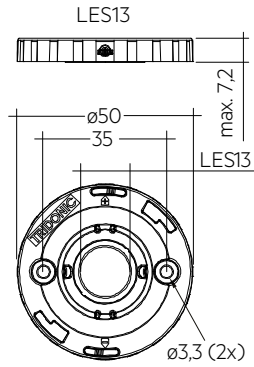

Dimensions in mm, \*optical LES

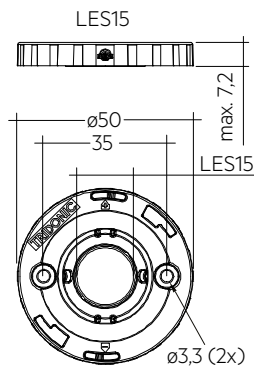

Dimensions in mm, \*optical LES

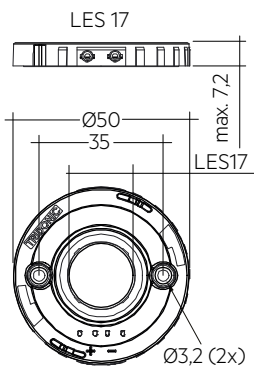

Dimensions in mm, \*optical LES

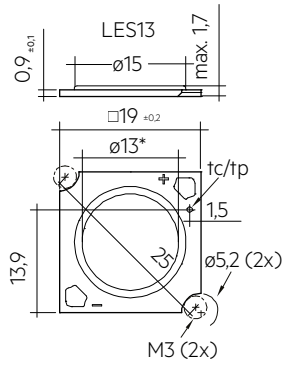

Dimensions in mm, \*optical LES

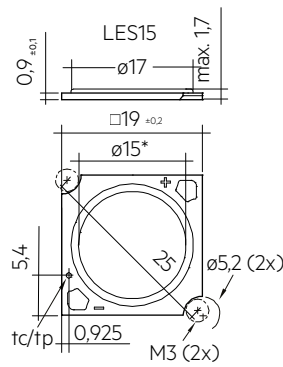

Dimensions in mm, \*optical LES

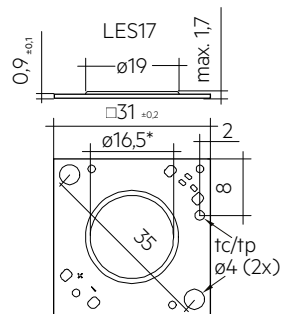

Dimensions in mm, \*optical LES

**Ordering data**

Type	Article number	Colour temperature	Packaging, carton	Weight per pc.
<b>SLE G7 13mm – Without housing</b>				
SLE G7 13mm 3000lm 930 PW R EXC	28002704	3,000 K	20 pc(s).	0.001 kg
<b>SLE G7 13mm – With housing</b>				
SLE G7 13mm 3000lm 930 PW H EXC	28002741	3,000 K	50 pc(s).	0.007 kg
SLE G7 13mm 3000lm 940 PW H EXC	28002742	4,000 K	50 pc(s).	0.007 kg
<b>SLE G7 15mm – Without housing</b>				
SLE G7 15mm 4000lm 930 PW R EXC	28002710	3,000 K	20 pc(s).	0.002 kg
<b>SLE G7 15mm – With housing</b>				
SLE G7 15mm 4000lm 930 PW H EXC	28002743	3,000 K	50 pc(s).	0.007 kg
SLE G7 15mm 4000lm 940 PW H EXC	28002744	4,000 K	50 pc(s).	0.007 kg
<b>SLE G7 17mm – Without housing</b>				
SLE G7 17mm 5000lm 930 PW R EXC	28002713	3,000 K	10 pc(s).	0.002 kg
<b>SLE G7 17mm – With housing</b>				
SLE G7 17mm 5000lm 930 PW H EXC	28002747	3,000 K	50 pc(s).	0.007 kg
SLE G7 17mm 5000lm 940 PW H EXC	28002748	4,000 K	50 pc(s).	0.007 kg

**Technical data**

Beam characteristic	115°
Ambient temperature $t_a$	-30 ... +80 °C
$t_p$ rated	65 °C
$t_c$ <sup>①</sup>	105 °C
I <sub>rated</sub> for LES13	500 mA
I <sub>rated</sub> for LES15	900 mA
I <sub>rated</sub> for LES17	1,050 mA
I <sub>max</sub> for LES13 <sup>①</sup>	990 mA
I <sub>max</sub> for LES15 <sup>①</sup>	1,320 mA
I <sub>max</sub> for LES17 <sup>①</sup>	1,540 mA
Max. permissible LF current ripple for LES13	1,440 mA
Max. permissible LF current ripple for LES15	1,920 mA
Max. permissible LF current ripple for LES17	1,680 mA
Max. permissible peak current for LES13	1,800 mA / max. 8 ms
Max. permissible peak current for LES15	2,160 mA / max. 8 ms
Max. permissible peak current for LES17	2,520 mA / max. 8 ms
Max. working voltage for insulation SELV <sup>②</sup>	< 60 V
Insulation test voltage	0.5 kV
CTI of the printed circuit board	≥ 600
Colour tolerance	3 SDCM
ESD classification	Severity level 4
Risk group (IEC 62471)	RG1
Type of protection	IP00
Lumen maintenance L70B50	55,000 h
Guarantee (conditions at <a href="http://www.tridonic.com">www.tridonic.com</a> )	5 Year(s)

**Approval marks****Standards**

EN 62031, EN 62471, IEC 62717, IEC 61000-4-2, UL 8750

## Specific technical data

Type	Article number	Photometric code	Useful luminous flux at $t_p = 25^\circ\text{C}$ <sup>③</sup>	Expected luminous flux at $t_p$ rated <sup>④</sup>	Typ. forward current	Min. forward voltage at $t_p$ rated	Max. forward voltage at $t_p = 25^\circ\text{C}$	Power consumption $P_{on}$ at $t_p = 25^\circ\text{C}$ <sup>⑤</sup>	Efficacy of the module at $t_p = 25^\circ\text{C}$	Expected efficacy of the module at $t_p$ rated	Colour rendering index: CRI
<b>SLE 13mm 3000lm – Operating mode HE at 350 mA</b>											
SLE G7 13mm 3000lm 930 PW R EXC	28002704	930/359	-	1,629 lm	350 mA	33.6 V	34.1 V	-	-	138 lm/W	>90
SLE G7 13mm 3000lm 930 PW H EXC	28002741	930/359	-	1,369 lm	350 mA	33.6 V	34.1 V	-	-	116 lm/W	>90
SLE G7 13mm 3000lm 940 PW H EXC	28002742	940/359	-	1,421 lm	350 mA	33.6 V	34.1 V	-	-	121 lm/W	>90
<b>SLE 13mm 3000lm – Operating mode NM at 500 mA</b>											
SLE G7 13mm 3000lm 930 PW R EXC	28002704	930/359	2,433 lm	2,276 lm	500 mA	34.6 V	35.1 V	17.6 W	138 lm/W	131 lm/W	>90
SLE G7 13mm 3000lm 930 PW H EXC	28002741	930/359	2,433 lm	2,276 lm	500 mA	34.6 V	35.1 V	17.6 W	116 lm/W	110 lm/W	>90
SLE G7 13mm 3000lm 940 PW H EXC	28002742	940/359	2,123 lm	1,982 lm	500 mA	34.6 V	35.1 V	17.6 W	121 lm/W	115 lm/W	>90
<b>SLE 13mm 3000lm – Operating mode HO at 900 mA</b>											
SLE G7 13mm 3000lm 930 PW R EXC	28002704	930/359	-	3,856 lm	900 mA	37.0 V	37.5 V	-	-	116 lm/W	>90
SLE G7 13mm 3000lm 930 PW H EXC	28002741	930/359	-	3,240 lm	900 mA	37.0 V	37.5 V	-	-	97 lm/W	>90
SLE G7 13mm 3000lm 940 PW H EXC	28002742	940/359	-	3,362 lm	900 mA	37.0 V	37.5 V	-	-	101 lm/W	>90
<b>SLE 15mm 4000lm – Operating mode HE at 500 mA</b>											
SLE G7 15mm 4000lm 930 PW R EXC	28002710	930/359	-	2,315 lm	500 mA	33.4 V	33.9 V	-	-	139 lm/W	>90
SLE G7 15mm 4000lm 930 PW H EXC	28002743	930/359	-	1,945 lm	500 mA	33.4 V	33.9 V	-	-	117 lm/W	>90
SLE G7 15mm 4000lm 940 PW H EXC	28002744	940/359	-	2,045 lm	500 mA	33.4 V	33.9 V	-	-	122 lm/W	>90
<b>SLE 15mm 4000lm – Operating mode NM at 900 mA</b>											
SLE G7 15mm 4000lm 930 PW R EXC	28002710	930/359	4,285 lm	3,999 lm	900 mA	35.0 V	35.5 V	32.0 W	134 lm/W	127 lm/W	>90
SLE G7 15mm 4000lm 930 PW H EXC	28002743	930/359	4,285 lm	3,999 lm	900 mA	35.0 V	35.5 V	32.0 W	113 lm/W	107 lm/W	>90
SLE G7 15mm 4000lm 940 PW H EXC	28002744	940/359	3,773 lm	3,531 lm	900 mA	35.0 V	35.5 V	32.0 W	118 lm/W	112 lm/W	>90
<b>SLE 15mm 4000lm – Operating mode HO at 1,200 mA</b>											
SLE G7 15mm 4000lm 930 PW R EXC	28002710	930/359	-	5,191 lm	1,200 mA	36.1 V	36.6 V	-	-	120 lm/W	>90
SLE G7 15mm 4000lm 930 PW H EXC	28002743	930/359	-	4,363 lm	1,200 mA	36.1 V	36.6 V	-	-	101 lm/W	>90
SLE G7 15mm 4000lm 940 PW H EXC	28002744	940/359	-	4,582 lm	1,200 mA	36.1 V	36.6 V	-	-	106 lm/W	>90
<b>SLE 17mm 5000lm – Operating mode HE at 500 mA</b>											
SLE G7 17mm 5000lm 930 PW R EXC	28002713	930/359	-	2,375 lm	500 mA	33.3 V	34.0 V	-	-	142 lm/W	>90
SLE G7 17mm 5000lm 930 PW H EXC	28002747	930/359	-	2,375 lm	500 mA	33.3 V	34.0 V	-	-	119 lm/W	>90
SLE G7 17mm 5000lm 940 PW H EXC	28002748	940/359	-	2,078 lm	500 mA	33.3 V	34.0 V	-	-	124 lm/W	>90
<b>SLE 17mm 5000lm – Operating mode NM at 1,050 mA</b>											
SLE G7 17mm 5000lm 930 PW R EXC	28002713	930/359	5,050 lm	4,730 lm	1,050 mA	34.8 V	35.5 V	37.3 W	135 lm/W	130 lm/W	>90
SLE G7 17mm 5000lm 930 PW H EXC	28002747	930/359	4,244 lm	3,975 lm	1,050 mA	34.8 V	35.5 V	37.3 W	114 lm/W	109 lm/W	>90
SLE G7 17mm 5000lm 940 PW H EXC	28002748	940/359	4,425 lm	4,140 lm	1,050 mA	34.8 V	35.5 V	37.3 W	119 lm/W	113 lm/W	>90
<b>SLE 17mm 5000lm – Operating mode HO at 1,400 mA</b>											
SLE G7 17mm 5000lm 930 PW R EXC	28002713	930/359	-	6,116 lm	1,400 mA	35.6 V	36.3 V	-	-	123 lm/W	>90
SLE G7 17mm 5000lm 930 PW H EXC	28002747	930/359	-	6,116 lm	1,400 mA	35.6 V	36.3 V	-	-	103 lm/W	>90
SLE G7 17mm 5000lm 940 PW H EXC	28002748	940/359	-	5,354 lm	1,400 mA	35.6 V	36.3 V	-	-	107 lm/W	>90

① See derating curves in data sheet section 2.3.

② The detailed explanation, see data sheet section 3.1.

③ Tolerance of useful light flux - 0 % / + 15 %. Measurement uncertainty  $\pm 10\%$ .

④ Tolerance of expected light flux - 0 % / + 15 %. Measurement uncertainty  $\pm 10\%$ . Based on calculation.

⑤ Tolerance of power consumption  $P_{on} \pm 10\%$ . Measurement uncertainty  $\pm 5\%$ .

## Housing for SLE

Accessory



## Product description

- \_ Housing for SLE
- \_ Diameter: 35 mm
- \_ Material: Lexan Resin 943
- \_ M3 screws with flat head, max. head diameter of 6 mm and max. torque for fixing is 0.5 Nm

## Website

<http://www.tridonic.com/28003026>



LES13

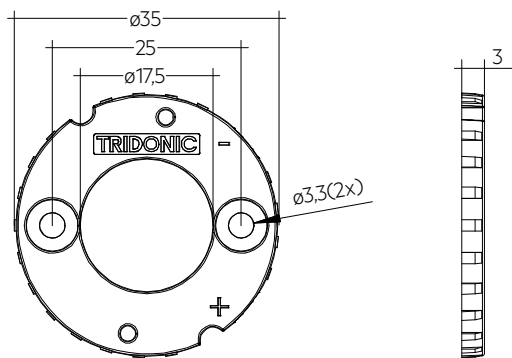

SLE G7 HOUSING LES13/15

## Ordering data

Type	Article number	Packaging, bag	Weight per pc.
SLE G7 HOUSING LES 13/15	28003026	500 pc(s).	0.002 kg

## 1. Standards

EN 62031  
 EN 62471  
 IEC 62717  
 IEC 61000-4-2  
 UL 8750 (for CLASS2 circuits and dry locations)

### 1.1 Glow wire test for housing variants

according to IEC 60695-2-11 with increased temperature of 850 °C passed.

### 1.2 Photometric code

Key for photometric code, e. g. 830 / 359

1 <sup>st</sup> digit	2 <sup>nd</sup> + 3 <sup>rd</sup> digit	4 <sup>th</sup> digit	5 <sup>th</sup> digit	6 <sup>th</sup> digit
Code CRI	Colour temperature in Kelvin x 100	MacAdam initial	MacAdam after 25% of the lifetime (max.6000h)	Luminous flux after 25% of the lifetime (max.6000h)
7 70 – 79				Code Luminous flux
8 80 – 89				7 ≥ 70 %
9 ≥90				8 ≥ 80 % 9 ≥ 90 %

### 1.3 Energy classification

Type	Colour temperature	Forward current	Energy classification	Energy consumption
<b>SLE G7 13mm – Without housing</b>				
SLE G7 13mm 3000lm 930 PW R EXC	3,000 K	500 mA	E	18 kWh / 1,000 h
<b>SLE G7 13mm – With housing</b>				
SLE G7 13mm 3000lm 930 PW H EXC	3,000 K	500 mA	E	18 kWh / 1,000 h
SLE G7 13mm 3000lm 940 PW H EXC	4,000 K	500 mA	E	18 kWh / 1,000 h
<b>SLE G7 15mm – Without housing</b>				
SLE G7 15mm 4000lm 930 PW R EXC	3,000 K	900 mA	E	32 kWh / 1,000 h
<b>SLE G7 15mm – With housing</b>				
SLE G7 15mm 4000lm 930 PW H EXC	3,000 K	900 mA	E	32 kWh / 1,000 h
SLE G7 15mm 4000lm 940 PW H EXC	4,000 K	900 mA	E	32 kWh / 1,000 h
<b>SLE G7 17mm – Without housing</b>				
SLE G7 17mm 5000lm 930 PW R EXC	3,000 K	1,050 mA	E	38 kWh / 1,000 h
<b>SLE G7 17mm – With housing</b>				
SLE G7 17mm 5000lm 930 PW H EXC	3,000 K	1,050 mA	E	38 kWh / 1,000 h
SLE G7 17mm 5000lm 940 PW H EXC	4,000 K	1,050 mA	E	38 kWh / 1,000 h

Energy label and further information at [www.tridonic.com](http://www.tridonic.com) in the certificates tab of the corresponding product page and at the EPREL data base <https://eprel.ec.europa.eu/>

## 2. Thermal details

### 2.1 tp point, ambient temperature and lifetime

The temperature at tp reference point is crucial for the light output and lifetime of a LED product.

For SLE G7 a tp temperature of 65 °C has to be complied in order to achieve an optimum between heat sink requirements, light output and lifetime.

Compliance with the maximum permissible reference temperature at the tp point must be checked under operating conditions in a thermally stable state. The maximum value must be determined under worst-case conditions for the relevant application.

The tc and tp temperature of LED modules from Tridonic are measured at the same reference point.

To check the tc / tp temperature, the temperature sensor has to be mounted on the PCB at the marked position as stated in the drawing.

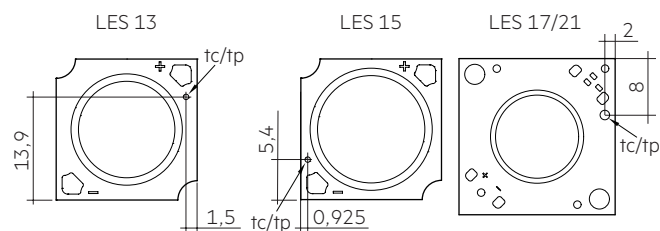

### 2.2 Storage and humidity

storage temperature	-30...+80 °C
---------------------	--------------

Operation only in non condensing environment.

Humidity during processing of the module should be between 0 to 85 %.

### 2.3 Derating curves

#### SLE G7 13mm 3000lm 9x0 EXC

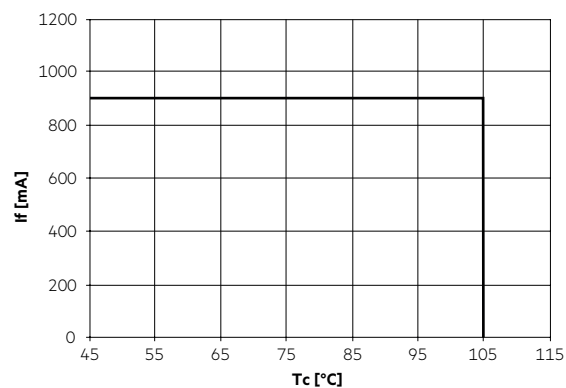

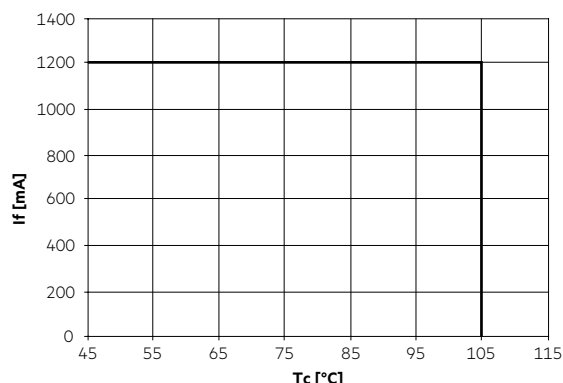
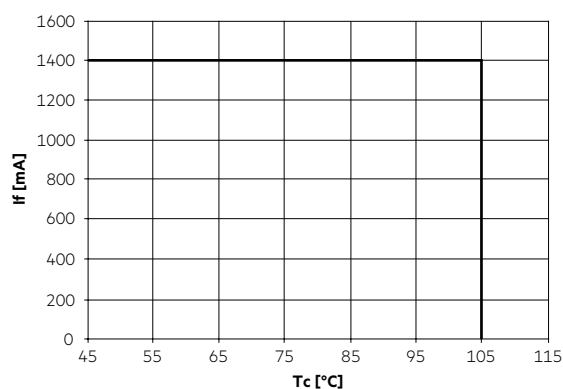
**SLE G7 15mm 4000lm 9x0 EXC****SLE G7 17mm 5000lm 9x0 EXC****2.4 Thermal design and heat sink**

The rated life of LED products depends to a large extent on the temperature. If the permissible temperature limits are exceeded, the life of the SLE G7 will be greatly reduced or the SLE G7 may be destroyed.

**2.5 Heat sink values****SLE G7 13mm 3000lm 9x0 EXC**

ta	tp	Operating current	R <sub>th, hs-a</sub>
25°C	65°C	350 mA	3.4 K/W
35°C	65°C	350 mA	2.6 K/W
45°C	65°C	350 mA	1.7 K/W
25°C	65°C	500 mA	2.3 K/W
35°C	65°C	500 mA	1.7 K/W
45°C	65°C	500 mA	1.2 K/W
25°C	65°C	900 mA	1.2 K/W
35°C	65°C	900 mA	0.9 K/W
45°C	65°C	900 mA	0.6 K/W

**SLE G7 15mm 4000lm 9x0 EXC**

ta	tp	Operating current	R <sub>th, hs-a</sub>
25°C	65°C	500 mA	2.4 K/W
35°C	65°C	500 mA	1.8 K/W
45°C	65°C	500 mA	1.2 K/W
25°C	65°C	900 mA	1.3 K/W
35°C	65°C	900 mA	1.0 K/W
45°C	65°C	900 mA	0.6 K/W
25°C	65°C	1,200 mA	0.9 K/W
35°C	65°C	1,200 mA	0.7 K/W
45°C	65°C	1,200 mA	0.5 K/W

**SLE G7 17mm 5000lm 9x0 EXC**

ta	tp	Operating current	R <sub>th, hs-a</sub>
25°C	65°C	500 mA	2.3 K/W
35°C	65°C	500 mA	1.7 K/W
45°C	65°C	500 mA	1.1 K/W
25°C	65°C	1,050 mA	1.0 K/W
35°C	65°C	1,050 mA	0.7 K/W
45°C	65°C	1,050 mA	0.4 K/W
25°C	65°C	1,400 mA	0.7 K/W
35°C	65°C	1,400 mA	0.5 K/W
45°C	65°C	1,400 mA	0.3 K/W

**Notes**

The actual cooling can differ because of the material, the structural shape, outside influences and the installation situation. A thermal connection between SLE G7 and heat sink with heat-conducting paste or heat conducting adhesive film is absolutely necessary.

Additionally the SLE G7 has to be fixed on the heat sink with M3 screws to optimise the thermal connection.

Use of thermal interface material with thermal conductivity of  $\lambda > 1$  W/mK and layer thickness of interface material with max. 50  $\mu\text{m}$  or a similar interface material where the quotient of layer thickness and thermal conductivity  $b < 50$   $\mu\text{mmK/W}$ .

**3. Installation / wiring****3.1 Electrical supply/choice of LED driver**

SLE G7 from Tridonic are not protected against overvoltages, overcurrents, overloads or short-circuit currents. Safe and reliable operation can only be guaranteed in conjunction with a LED driver which complies with the relevant standards. The use of LED drivers from Tridonic in combination with SLE G7 guarantees the necessary protection for safe and reliable operation.

If a LED driver other than Tridonic is used, it must provide the following protection:

- Short-circuit protection
- Overload protection
- Overtemperature protection



SLE G7 must be supplied by a constant current LED driver. Operation with a constant voltage LED driver will lead to an irreversible damage of the module. Wrong polarity can damage the SLE G7.



SLE G7 must not be operated with nonSELV LED driver.



SLE G7 are basic insulated up to 60 V SELV against ground and can be mounted directly on earthed metal parts of the luminaire. If the max. output voltage of the LED driver (also against earth) is above 60 V SELV, an additional insulation between LED module and heat sink is required (for example by insulated thermal pads) or by a suitable luminaire construction.

At voltages > 60 V an additional protection against direct touch (test finger) to the light emitting side of the module has to be guaranteed. This is typically achieved by means of a non removable light distributor over the module.

### 3.2 Wiring

#### Wiring with housing (LES13 and LES15)

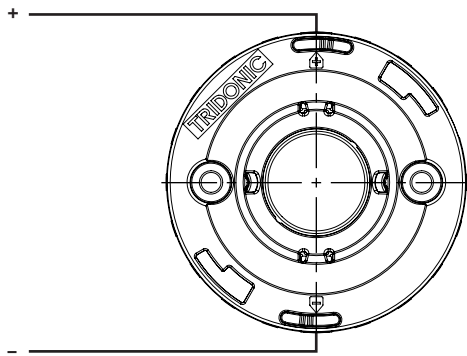

#### Wiring with housing (LES17)

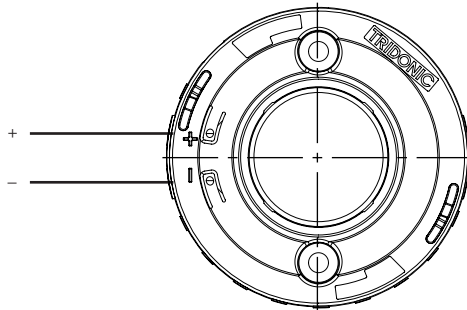

#### Wiring without housing

##### LES13

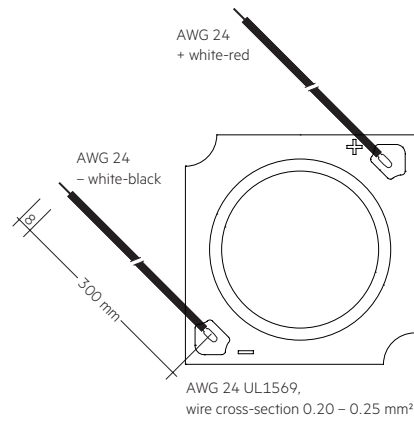

##### LES15

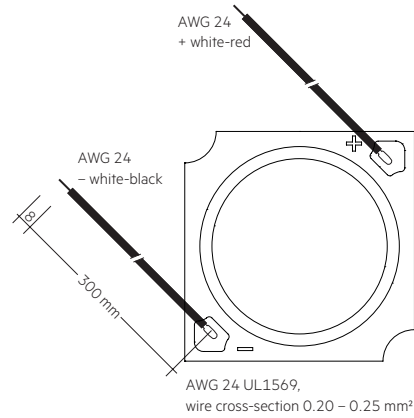

##### LES17 + LES21

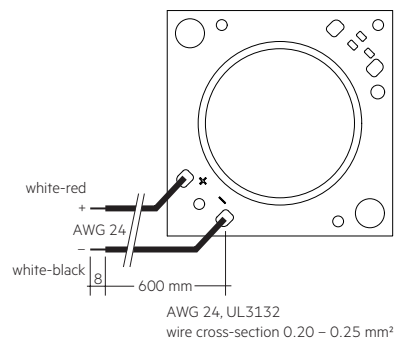

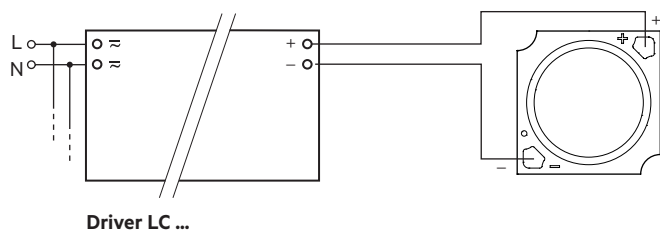
**Wiring example****3.3 Wiring type and cross section for housing variants**

For wiring use solid wire from 0.5 to 0.75 mm<sup>2</sup> or stranded wire with soldered ends of 0.5 mm<sup>2</sup>.

For the push-wire connection you have to strip the insulation (6 – 7 mm).

Loosen wire through twisting and pulling.

wire preparation:

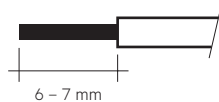
**3.4 Mounting instruction**

SLE G7 from Tridonic which have to be installed on a heat sink have to be connected with heat-conducting paste or heat conducting adhesive film and fixed with M3 screws.

The fixing/cooling surface must be cleaned by removing all dirt, dust and grease before installing the LED modules.

None of the components of the SLE G7 (substrate, LED, electronic components etc.) may be exposed to tensile or compressive stresses.



Max. torque for fixing: 0.3 Nm (LES13, LES15)  
0.5 Nm (LES17)

The LED modules are mounted with 2 screws per module. In order not to damage the modules only rounded head screws and an additional plastic flat washer (notice working temperature) or rounded head screw with collar (ISO 7380-2) with head diameter  $\geq$  6.9 mm must be used for LED modules without housing (for LES13, LES15).

For further information please refer to the brochure entitled "Technical Design-In-Guide SLE GEN7".



Chemical substance may harm the LED module. Chemical reactions could lead to colour shift, reduced luminous flux or a total failure of the module caused by corrosion of electrical connections.

Materials which are used in LED applications (e.g. sealings, adhesives) must not produce dissolver gas. They must not be condensation curing based, acetate curing based or contain sulfur, chlorine or phthalate.

Avoid corrosive atmosphere during usage and storage.

**3.5 EOS/ESD safety guidelines**

The device / module contains components that are sensitive to electrostatic discharge and may only be installed in the factory and on site if appropriate EOS/ESD protection measures have been taken. No special measures need be taken for devices/modules with enclosed casings (contact with the pc board not possible), just normal installation practice.

For further information for EOS/ESD safety guidelines and the ESD classification please refer to the brochure entitled <http://www.tridonic.com/esd-protection>.

## 4. Lifetime

### 4.1 Lifetime, lumen maintenance and failure rate

The light output of an LED module decreases over the lifetime, this is characterized with the L value. L70 means that the LED module will give 70 % of its initial luminous flux. This value is always related to the number of operation hours and therefore defines the lifetime of an LED module.

As the L value is a statistical value and the lumen maintenance may vary over the delivered LED modules. The B value defines the amount of modules which are below the specific L value, e.g. L70B10 means 10 % of the LED modules are below 70 % of the initial luminous flux, respectively 90 % will be above 70 % of the initial value.

In addition the percentage of failed modules (fatal failure) is characterized by the C value.

The F value is the combination of the B and C value. That means for F degradation and complete failures are considered, e.g. L70F10 means 10 % of the LED modules may fail or be below 70 % of the initial luminous flux.

### 4.2 Lumen maintenance

Lifetime declarations are informative and represent no warranty claim. Preliminary calculated lifetime data until LM80 test reports are available

#### SLE G7 13mm 3000lm EXC

Operating current	tp temperature	L90 / F10	L90 / F50	L80 / F10	L80 / F50	L70 / F10	L70 / F50
350 mA	65 °C	50,000 h	>55,000 h	>55,000 h	>55,000 h	>55,000 h	>55,000 h
	85 °C	50,000 h	>55,000 h	>55,000 h	>55,000 h	>55,000 h	>55,000 h
	105 °C	26,000 h	37,000 h	>55,000 h	>55,000 h	>55,000 h	>55,000 h
500 mA	65 °C	50,000 h	>55,000 h	>55,000 h	>55,000 h	>55,000 h	>55,000 h
	85 °C	50,000 h	>55,000 h	>55,000 h	>55,000 h	>55,000 h	>55,000 h
	105 °C	26,000 h	37,000 h	>55,000 h	>55,000 h	>55,000 h	>55,000 h
900 mA	65 °C	37,000 h	51,000 h	>55,000 h	>55,000 h	>55,000 h	>55,000 h
	85 °C	37,000 h	51,000 h	>55,000 h	>55,000 h	>55,000 h	>55,000 h
	105 °C	13,000 h	20,000 h	31,000 h	49,000 h	50,000 h	>55,000 h

#### SLE G7 15mm 4000lm EXC

Operating current	tp temperature	L90 / F10	L90 / F50	L80 / F10	L80 / F50	L70 / F10	L70 / F50
500 mA	65 °C	50,000 h	>55,000 h	>55,000 h	>55,000 h	>55,000 h	>55,000 h
	85 °C	50,000 h	>55,000 h	>55,000 h	>55,000 h	>55,000 h	>55,000 h
	105 °C	26,000 h	37,000 h	>55,000 h	>55,000 h	>55,000 h	>55,000 h
900 mA	65 °C	50,000 h	>55,000 h	>55,000 h	>55,000 h	>55,000 h	>55,000 h
	85 °C	50,000 h	>55,000 h	>55,000 h	>55,000 h	>55,000 h	>55,000 h
	105 °C	26,000 h	37,000 h	>55,000 h	>55,000 h	>55,000 h	>55,000 h
1,200 mA	65 °C	>55,000 h	>55,000 h	>55,000 h	>55,000 h	>55,000 h	>55,000 h
	85 °C	>55,000 h	>55,000 h	>55,000 h	>55,000 h	>55,000 h	>55,000 h
	105 °C	13,000 h	20,000 h	31,000 h	49,000 h	51,000 h	>55,000 h

#### SLE G7 17mm 5000lm EXC

Operating current	tp temperature	L90 / F10	L90 / F50	L80 / F10	L80 / F50	L70 / F10	L70 / F50
500 mA	65 °C	50,000 h	>55,000 h	>55,000 h	>55,000 h	>55,000 h	>55,000 h
	85 °C	50,000 h	>55,000 h	>55,000 h	>55,000 h	>55,000 h	>55,000 h
	105 °C	26,000 h	37,000 h	>55,000 h	>55,000 h	>55,000 h	>55,000 h
1,050 mA	65 °C	50,000 h	>55,000 h	>55,000 h	>55,000 h	>55,000 h	>55,000 h
	85 °C	50,000 h	>55,000 h	>55,000 h	>55,000 h	>55,000 h	>55,000 h
	105 °C	26,000 h	37,000 h	>55,000 h	>55,000 h	>55,000 h	>55,000 h
1,400 mA	65 °C	>55,000 h	>55,000 h	>55,000 h	>55,000 h	>55,000 h	>55,000 h
	85 °C	>55,000 h	>55,000 h	>55,000 h	>55,000 h	>55,000 h	>55,000 h
	105 °C	13,000 h	20,000 h	31,000 h	50,000 h	51,000 h	>55,000 h

## 5. Electrical values

### 5.1 Declaration of electrical parameters

$I_{rated}$  ... Nominal operating current the module is designed for.

$I_{max}$  ... Max. permissible continuous operating current incl. The tolerances of the LED driver.

Max. permissible LF current ripple ... Max. output current of the LED driver incl. Tolerances and LF current ripple must not exceed this value.

Max. permissible peak current ... The max. output peak current of the LED driver must not exceed this value.

### 5.2 Typ. forward voltage vs. forward current

**SLE G7 13mm 3000lm xxx EXC**

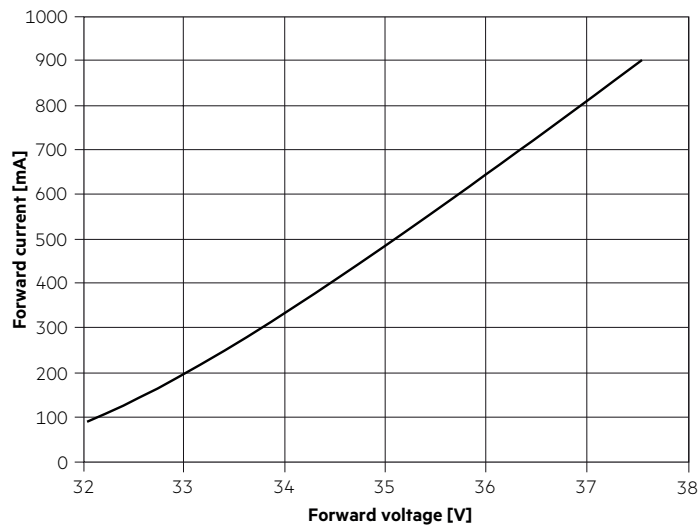

**SLE G7 15mm 4000lm xxx EXC**

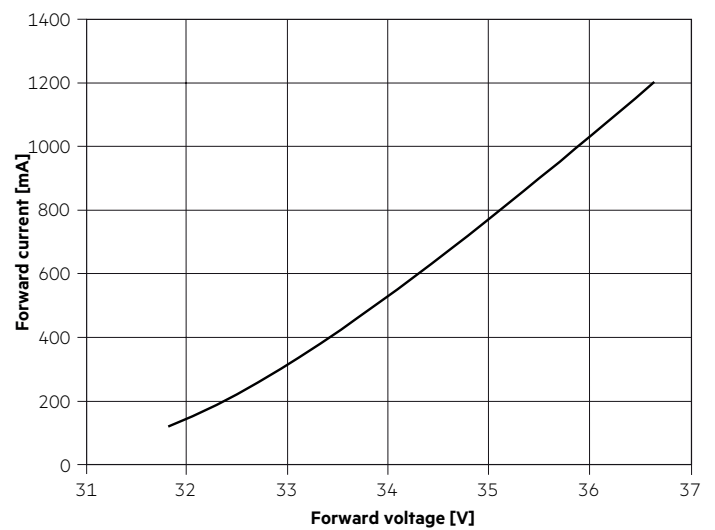

**SLE G7 17mm 5000lm xxx EXC**

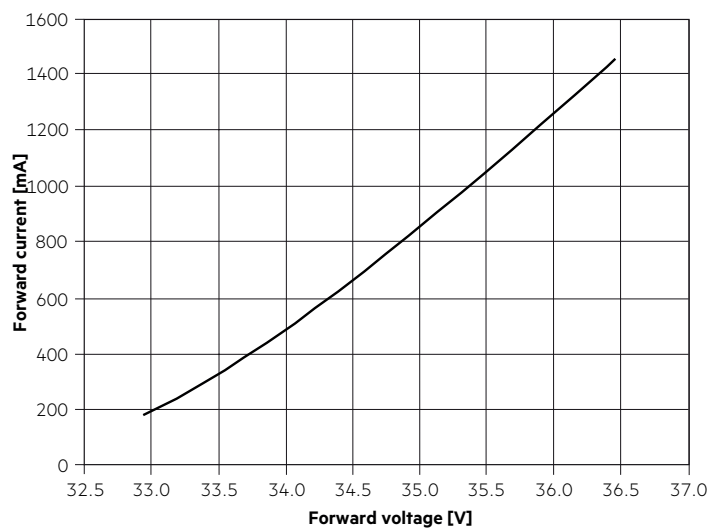

### 5.3 Forward voltage vs. $t_p$ temperature

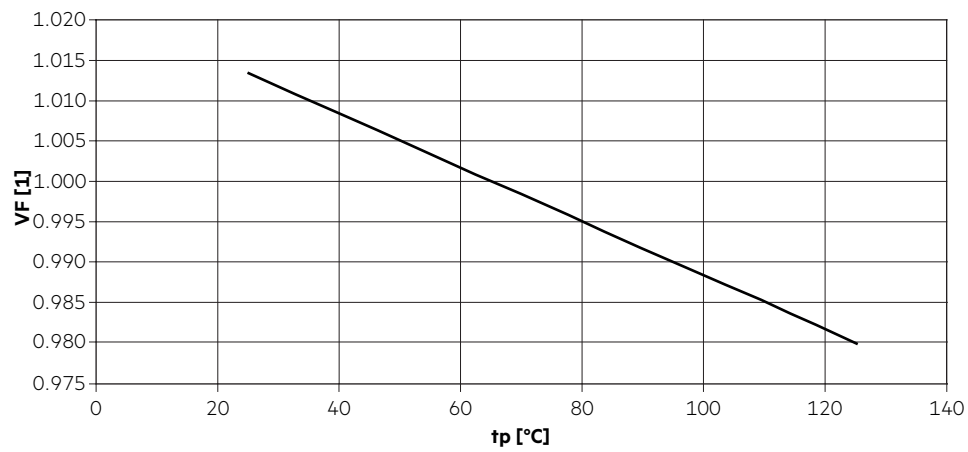

The diagrams based on statistic values.  
The real values can be different.

## 6. Photometric characteristics

### 6.1 Coordinates and tolerances according to CIE 1931 and colour rendering

The specified colour coordinates are measured integral after a settling time of 100 ms. The current impuls depends on the module type. The ambient temperature of the measurement is  $t_a = 25^\circ\text{C}$ . The measurement tolerance of the colour coordinates are  $\pm 0.01$ .

Module type	Current impulse
SLE G7 13mm 3000lm 9x0 EXC	500 mA
SLE G7 15mm 4000lm 9x0 EXC	900 mA
SLE G7 17mm 5000lm 9x0 EXC	1,050 mA

#### 3,000 K – CRI90

	x0	y0
Centre	0.4260	0.3930

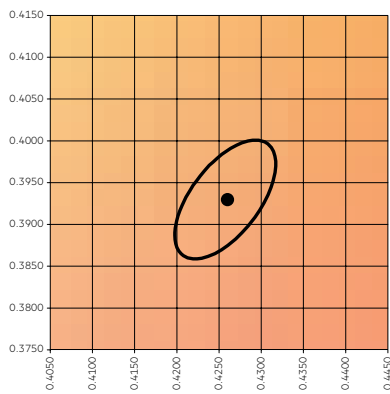

MacAdam ellipse: 3SDCM

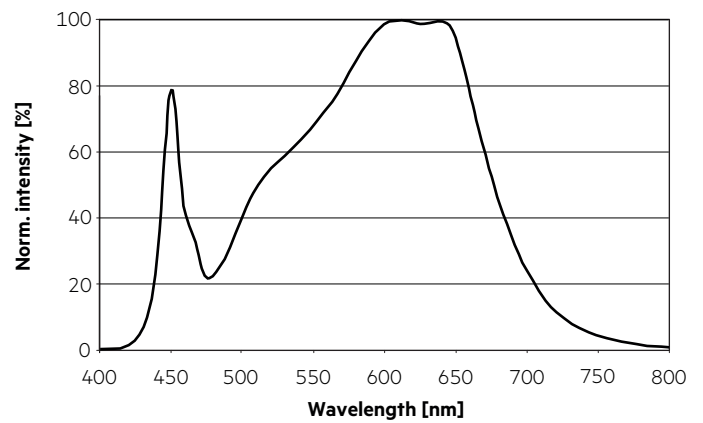

TM30		CRI	
Rf	Rg	Ra	R9
89	101	92	58

#### Colour vector graphic

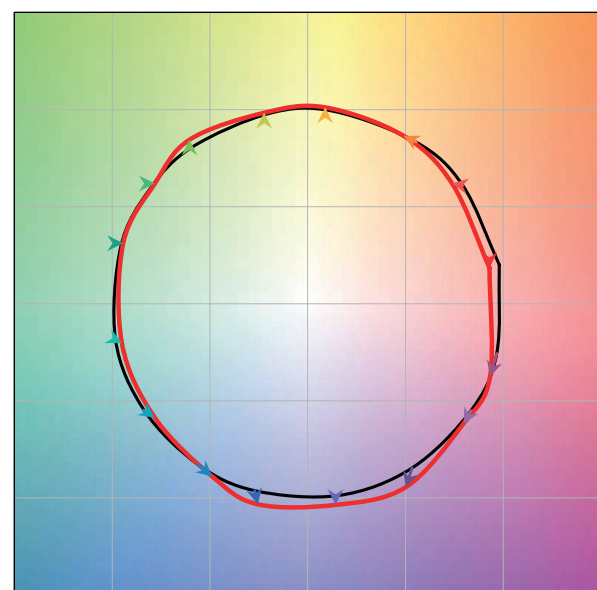

— Reference source  
— Test source

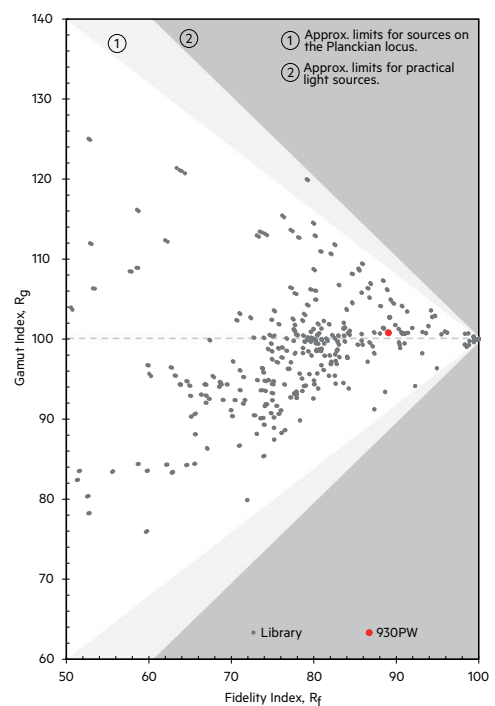

4,000 K – CRI90

	x0	y0
Centre	0.3774	0.3715

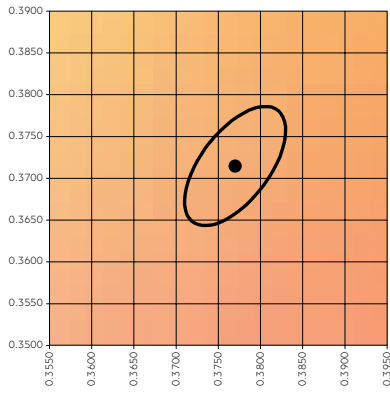

MacAdam ellipse: 3SDCM

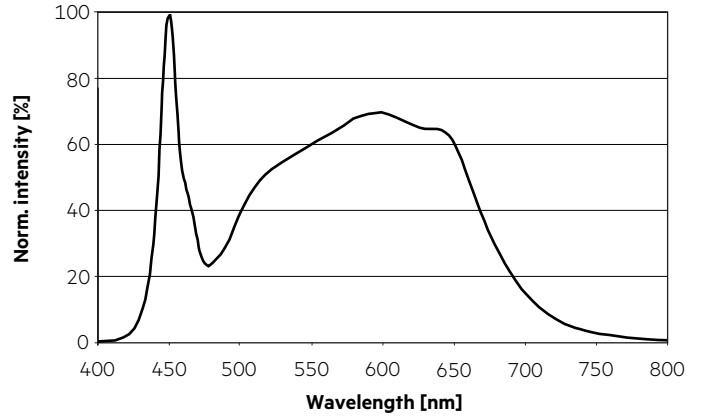

TM30		CRI	
Rf	Rg	Ra	R9
88	100	91	61

Colour vector graphic

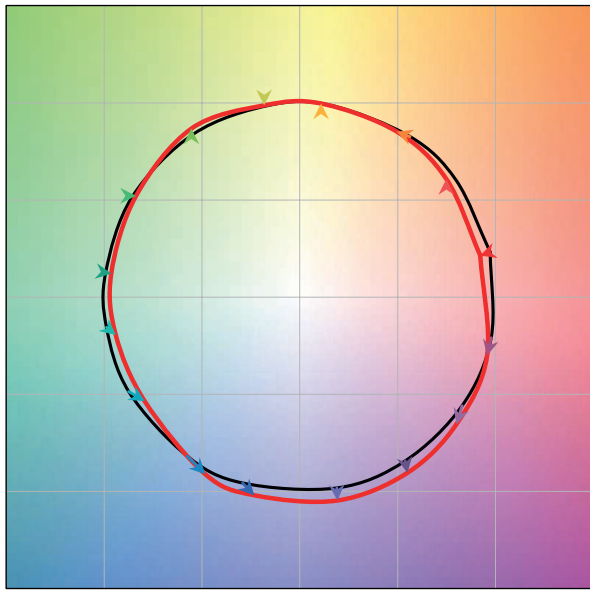

— Reference source  
 — Test source

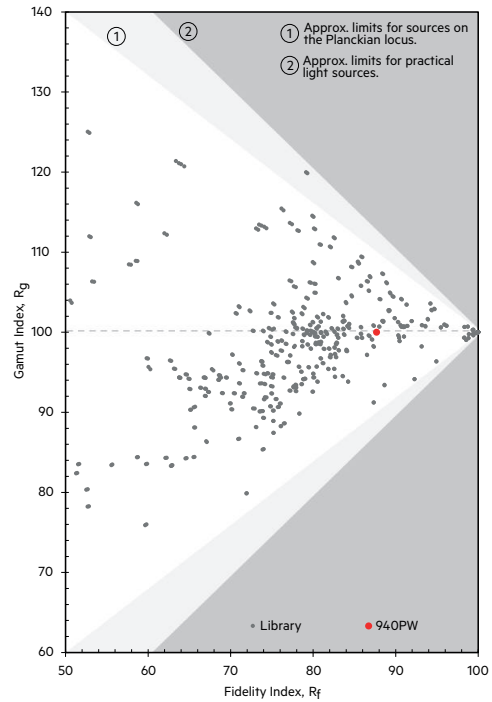

### 6.2 Light distribution

The optical design of the SLE product line ensures optimum homogeneity for the light distribution.

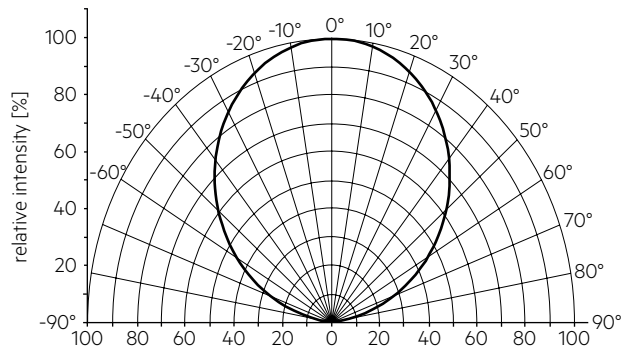

### 6.3 Relative luminous flux vs. tp temperature

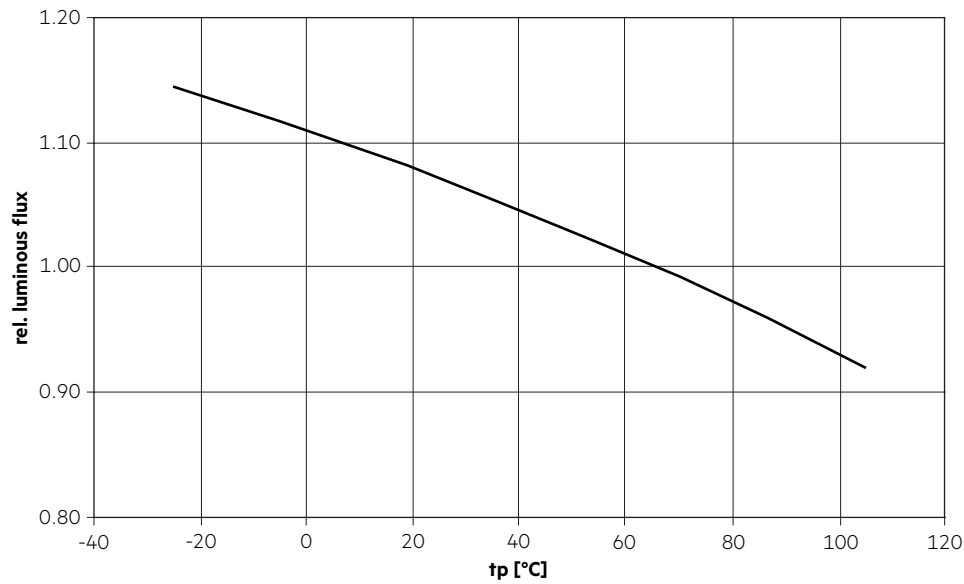

### 6.4 Relative luminous flux vs. operating current

SLE G7 13mm 3000lm xxx EXC

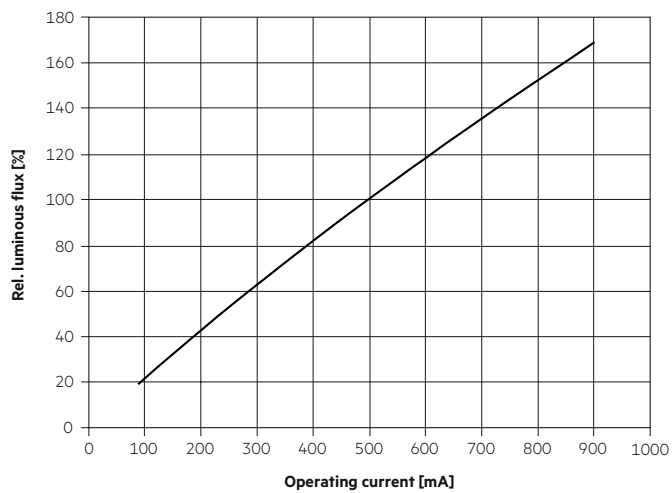

SLE G7 15mm 4000lm xxx EXC

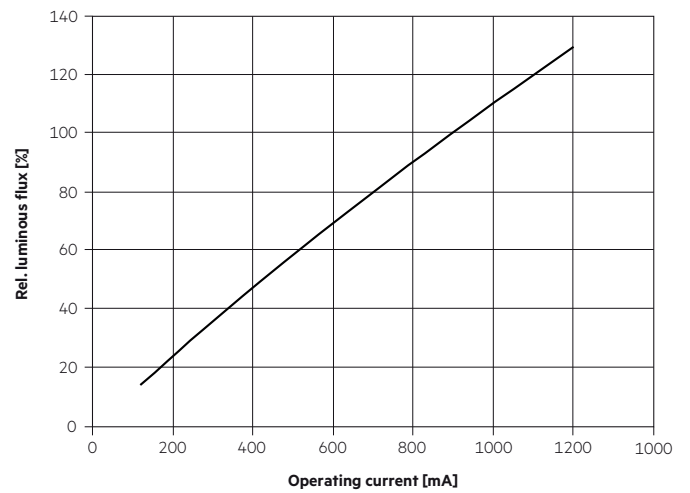

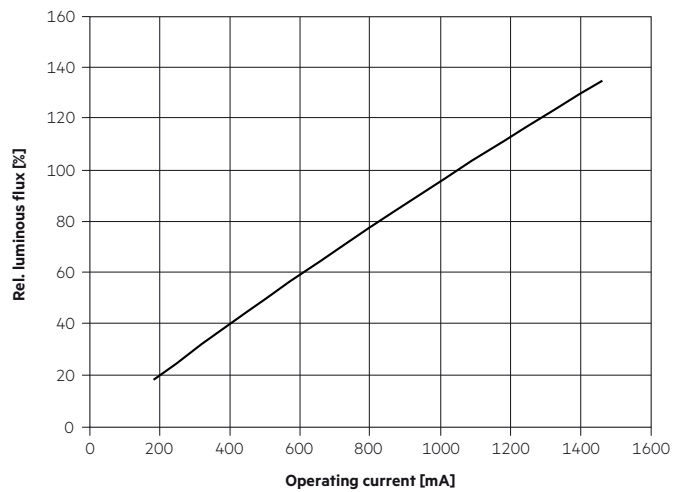
**SLE G7 17mm 5000lm xxx EXC****7. Miscellaneous****7.1 Additional information**

Additional technical information at [www.tridonic.com](http://www.tridonic.com) → Technical Data

Guarantee conditions at [www.tridonic.com](http://www.tridonic.com) → Services

Lifetime declarations are informative and represent no warranty claim.

Colour rendering information are typical values and represent no warranty claim.