

Module SLE EXC8+

Modules SLE excite

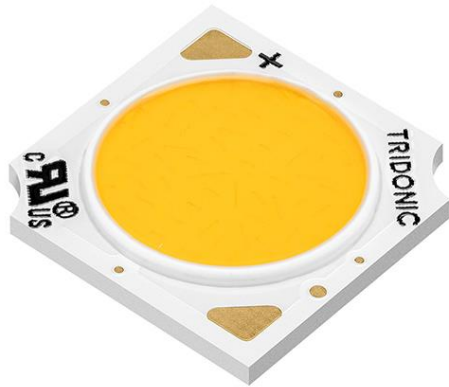

SLE 9mm R EXC8+

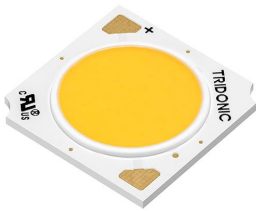

SLE 13mm R EXC8+

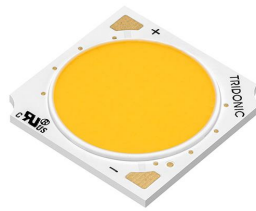

SLE 15mm R EXC8+

Product description

- _ For spotlights and downlights
- _ For operating with SELV Driver suitable
- _ CRI 90 product achieves the similar efficacy as traditional CRI 80 products
- _ Uniform high-quality illumination
- _ Pure White color specially for fashion store applications
- _ Integrated LED module
- _ Cooling required
- _ Flexible operating mode
- _ HE ... High Efficiency, NM ... Nominal Mode, HO ... High Output
- _ Long lifetime up to 100,000 hours
- _ 5 years guarantee (conditions at <https://www.tridonic.com/en/int/services/manufacturer-guarantee-conditions>)

Optical properties

- _ Colour temperatures 3,000, 3,500 and 4,000 K
- _ Useful luminous flux 8.500 lm at Irated and tp = 25 °C
- _ Efficacy of the LED module 174 lm/W at Irated and tp = 25 °C
- _ High colour rendering index CRI > 90
- _ Small colour tolerance (MacAdam 3)

Mechanical properties

- _ Module dimension LES09, LES13, LES15, LES17 and LES21
- _ Fixing holes for M3 screws

System solution

- _ Combine Tridonic's LED modules and dimmable drivers to achieve an outstanding system efficacy (configuration possible via <https://setbuilder.tridonic.com/>)

Website

<http://www.tridonic.com/28006555>



Linear



High bay



Decorative



Downlights



Spotlights



Free-standing



Area



Floor | Wall



Street

Module SLE EXC8+

Modules SLE excite

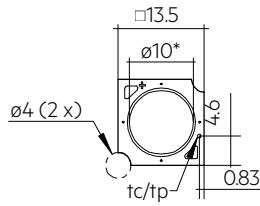
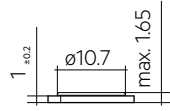

SLE 9mm R EXC8+

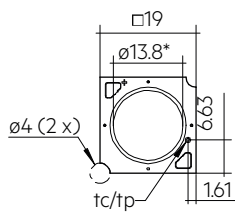
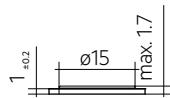

SLE 13mm R EXC8+

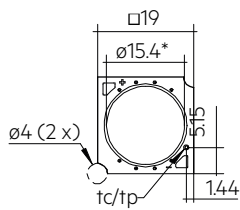
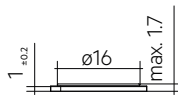

SLE 15mm R EXC8+

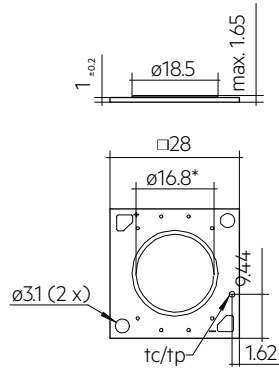

SLE 17mm R EXC8+

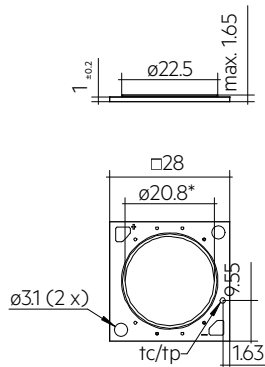

SLE 21mm R EXC8+

Ordering data

Type	Article number	Colour temperature	Colour rendering index CRI	Packaging, carton	Weight per pc.
SLE 09mm 2600lm 930 PW R EXC8+	28006555	3,000 K	>90	35 pc(s).	0.001 kg
SLE 09mm 2600lm 935 PW R EXC8+	28006556	3,500 K	>90	35 pc(s).	0.001 kg
SLE 09mm 2600lm 940 PW R EXC8+	28006557	4,000 K	>90	35 pc(s).	0.001 kg
SLE 13mm 3000lm 930 PW R EXC8+	28006562	3,000 K	>90	25 pc(s).	0.001 kg
SLE 13mm 3000lm 935 PW R EXC8+	28006563	3,500 K	>90	25 pc(s).	0.001 kg
SLE 13mm 3000lm 940 PW R EXC8+	28006564	4,000 K	>90	25 pc(s).	0.001 kg
SLE 15mm 4000lm 930 PW R EXC8+	28006569	3,000 K	>90	25 pc(s).	0.001 kg
SLE 15mm 4000lm 935 PW R EXC8+	28006570	3,500 K	>90	25 pc(s).	0.001 kg
SLE 15mm 4000lm 940 PW R EXC8+	28006571	4,000 K	>90	25 pc(s).	0.001 kg
SLE 17mm 5000lm 930 PW R EXC8+	28006576	3,000 K	>90	15 pc(s).	0.002 kg
SLE 17mm 5000lm 935 PW R EXC8+	28006577	3,500 K	>90	15 pc(s).	0.002 kg
SLE 17mm 5000lm 940 PW R EXC8+	28006578	4,000 K	>90	15 pc(s).	0.002 kg
SLE 21mm 6000lm 930 PW R EXC8+	28006583	3,000 K	>90	15 pc(s).	0.002 kg
SLE 21mm 6000lm 935 PW R EXC8+	28006584	3,500 K	>90	15 pc(s).	0.002 kg
SLE 21mm 6000lm 940 PW R EXC8+	28006585	4,000 K	>90	15 pc(s).	0.002 kg

Technical data

Beam characteristic	120°
Ambient temperature t_a	-40 ... +95 °C
t_p rated	65 °C
t_c ^①	105 °C
Irated for LES09 2,600 lm	500 mA
Irated for LES13	600 mA
Irated for LES15	800 mA
Irated for LES17	1,050 mA
Irated for LES21	1,400 mA
I _{max} for LES09 2,600 lm	720 mA
I _{max} for LES13	900 mA
I _{max} for LES15	1,440 mA
I _{max} for LES17	1,800 mA
I _{max} for LES21	2,520 mA
Max. perm. LF current ripple for LES09 2,600 lm	792 mA
Max. permissible LF current ripple for LES13	990 mA
Max. permissible LF current ripple for LES15	1,584 mA
Max. permissible LF current ripple for LES17	1,980 mA
Max. permissible LF current ripple for LES21	2,772 mA
Max. perm. peak current for LES09 2,600 lm	1,000 mA / max. 10 ms
Max. permissible peak current for LES13	1,250 mA / max. 10 ms
Max. permissible peak current for LES15	2,000 mA / max. 10 ms
Max. permissible peak current for LES17	2,500 mA / max. 10 ms
Max. permissible peak current for LES21	3,500 mA / max. 10 ms
Max. working voltage for insulation SELV ^②	< 60 V
Insulation test voltage	0.5 kV
Colour tolerance	3 SDCM
ESD classification	Severity level 1
Risk group (IEC 62471) for LES09 2,600lm (2700K, 3000K) at I _{max}	RG1
Risk group (IEC 62471) for LES09 2,600lm (3500K, 4000K)	RG2 (E _{thr} = 1980 lx, RG1 at d ≥ 213 cm (I _{max})), RG1 (l ≤ 560 mA)
Risk group (IEC 62471) for LES13 3,000lm at I _{max}	RG1
Risk group (IEC 62471) for LES15 4,000lm (2700K, 3000K) at I _{max}	RG1
Risk group (IEC 62471) for LES15 4,000lm (3500K, 4000K)	RG2 (E _{thr} = 1980 lx, RG1 at d ≥ 213 cm (I _{max})), RG1 (l ≤ 1360 mA)
Risk group (IEC 62471) for LES17 5,000lm (2700K, 3000K) at I _{max}	RG1
Risk group (IEC 62471) for LES17 5,000lm (3500K, 4000K)	RG2 (E _{thr} = 1980 lx, RG1 at d ≥ 213 cm (I _{max})), RG1 (l ≤ 1620 mA)
Risk group (IEC 62471) for LES21 6,000lm at I _{max}	RG1
Classification acc. to IEC 62031	Built-in
Type of protection	IP00
Lumen maintenance L70B50	100,000 h
Guarantee (conditions at www.tridonic.com)	5 Year(s)

Approval marks**Standards**

EN 62031, EN 62471, UL 8750, IEC 62778

Specific technical data

Type	Article number	Photometric code	Useful luminous flux at $t_p = 25\text{ }^\circ\text{C}$ ^③	Expected luminous flux at t_p rated ^④	Typ. forward current	Min. forward voltage at t_p rated	Max. forward voltage at $t_p = 25\text{ }^\circ\text{C}$	Power consumption P_{on} at $t_p = 25\text{ }^\circ\text{C}$ ^⑤	Efficacy of the module at $t_p = 25\text{ }^\circ\text{C}$	Expected efficacy of the module at t_p rated	Colour rendering index: CRI
SLE 09mm 2600lm – Operating mode HE at 300 mA											
SLE 09mm 2600lm 930 PW R EXC8+	28006555	930/359	–	1,635 lm	300 mA	31.0 V	36.6 V	–	–	163 lm/W	>90
SLE 09mm 2600lm 935 PW R EXC8+	28006556	935/359	–	1,638 lm	300 mA	31.0 V	36.6 V	–	–	163 lm/W	>90
SLE 09mm 2600lm 940 PW R EXC8+	28006557	940/359	–	1,667 lm	300 mA	31.0 V	36.6 V	–	–	166 lm/W	>90
SLE 09mm 2600lm – Operating mode NM at 500 mA											
SLE 09mm 2600lm 930 PW R EXC8+	28006555	930/359	2,785 lm	2,622 lm	500 mA	32.4 V	38.3 V	17.8 W	156 lm/W	150 lm/W	>90
SLE 09mm 2600lm 935 PW R EXC8+	28006556	935/359	2,790 lm	2,626 lm	500 mA	32.4 V	38.3 V	17.8 W	157 lm/W	150 lm/W	>90
SLE 09mm 2600lm 940 PW R EXC8+	28006557	940/359	2,840 lm	2,673 lm	500 mA	32.4 V	38.3 V	17.8 W	160 lm/W	153 lm/W	>90
SLE 09mm 2600lm – Operating mode HO at 650 mA											
SLE 09mm 2600lm 930 PW R EXC8+	28006555	930/359	–	3,320 lm	650 mA	33.5 V	39.5 V	–	–	141 lm/W	>90
SLE 09mm 2600lm 935 PW R EXC8+	28006556	935/359	–	3,326 lm	650 mA	33.5 V	39.5 V	–	–	141 lm/W	>90
SLE 09mm 2600lm 940 PW R EXC8+	28006557	940/359	–	3,385 lm	650 mA	33.5 V	39.5 V	–	–	144 lm/W	>90
SLE 13mm 3000lm – Operating mode HE at 350 mA											
SLE 13mm 3000lm 930 PW R EXC8+	28006562	930/359	–	2,032 lm	350 mA	30.8 V	36.4 V	–	–	174 lm/W	>90
SLE 13mm 3000lm 935 PW R EXC8+	28006563	935/359	–	2,001 lm	350 mA	30.8 V	36.4 V	–	–	172 lm/W	>90
SLE 13mm 3000lm 940 PW R EXC8+	28006564	940/359	–	2,081 lm	350 mA	30.8 V	36.4 V	–	–	179 lm/W	>90
SLE 13mm 3000lm – Operating mode NM at 600 mA											
SLE 13mm 3000lm 930 PW R EXC8+	28006562	930/359	3,560 lm	3,351 lm	600 mA	32.3 V	38.1 V	21.3 W	167 lm/W	160 lm/W	>90
SLE 13mm 3000lm 935 PW R EXC8+	28006563	935/359	3,505 lm	3,299 lm	600 mA	32.3 V	38.1 V	21.3 W	165 lm/W	158 lm/W	>90
SLE 13mm 3000lm 940 PW R EXC8+	28006564	940/359	3,645 lm	3,431 lm	600 mA	32.3 V	38.1 V	21.3 W	171 lm/W	164 lm/W	>90
SLE 13mm 3000lm – Operating mode HO at 800 mA											
SLE 13mm 3000lm 930 PW R EXC8+	28006562	930/359	–	4,396 lm	800 mA	33.5 V	39.5 V	–	–	152 lm/W	>90
SLE 13mm 3000lm 935 PW R EXC8+	28006563	935/359	–	4,328 lm	800 mA	33.5 V	39.5 V	–	–	150 lm/W	>90
SLE 13mm 3000lm 940 PW R EXC8+	28006564	940/359	–	4,501 lm	800 mA	33.5 V	39.5 V	–	–	156 lm/W	>90
SLE 15mm 4000lm – Operating mode HE at 500 mA											
SLE 15mm 4000lm 930 PW R EXC8+	28006569	930/359	–	2,835 lm	500 mA	30.5 V	36.1 V	–	–	172 lm/W	>90
SLE 15mm 4000lm 935 PW R EXC8+	28006570	935/359	–	2,866 lm	500 mA	30.5 V	36.1 V	–	–	174 lm/W	>90
SLE 15mm 4000lm 940 PW R EXC8+	28006571	940/359	–	2,904 lm	500 mA	30.5 V	36.1 V	–	–	176 lm/W	>90
SLE 15mm 4000lm – Operating mode NM at 800 mA											
SLE 15mm 4000lm 930 PW R EXC8+	28006569	930/359	4,678 lm	4,404 lm	800 mA	31.7 V	37.5 V	27.9 W	168 lm/W	161 lm/W	>90
SLE 15mm 4000lm 935 PW R EXC8+	28006570	935/359	4,730 lm	4,453 lm	800 mA	31.7 V	37.5 V	27.9 W	170 lm/W	162 lm/W	>90
SLE 15mm 4000lm 940 PW R EXC8+	28006571	940/359	4,792 lm	4,511 lm	800 mA	31.7 V	37.5 V	27.9 W	172 lm/W	165 lm/W	>90
SLE 15mm 4000lm – Operating mode HO at 1,050 mA											
SLE 15mm 4000lm 930 PW R EXC8+	28006569	930/359	–	5,646 lm	1,050 mA	32.6 V	38.5 V	–	–	153 lm/W	>90
SLE 15mm 4000lm 935 PW R EXC8+	28006570	935/359	–	5,708 lm	1,050 mA	32.6 V	38.5 V	–	–	154 lm/W	>90
SLE 15mm 4000lm 940 PW R EXC8+	28006571	940/359	–	5,784 lm	1,050 mA	32.6 V	38.5 V	–	–	156 lm/W	>90
SLE 17mm 5000lm – Operating mode HE at 700 mA											
SLE 17mm 5000lm 930 PW R EXC8+	28006576	930/359	–	3,870 lm	700 mA	30.8 V	36.4 V	–	–	166 lm/W	>90
SLE 17mm 5000lm 935 PW R EXC8+	28006577	935/359	–	3,818 lm	700 mA	30.8 V	36.4 V	–	–	164 lm/W	>90
SLE 17mm 5000lm 940 PW R EXC8+	28006578	940/359	–	3,954 lm	700 mA	30.8 V	36.4 V	–	–	170 lm/W	>90
SLE 17mm 5000lm – Operating mode NM at 1,050 mA											
SLE 17mm 5000lm 930 PW R EXC8+	28006576	930/359	6,000 lm	5,648 lm	1,050 mA	31.8 V	37.6 V	36.8 W	163 lm/W	156 lm/W	>90
SLE 17mm 5000lm 935 PW R EXC8+	28006577	935/359	5,920 lm	5,573 lm	1,050 mA	31.8 V	37.6 V	36.8 W	161 lm/W	154 lm/W	>90
SLE 17mm 5000lm 940 PW R EXC8+	28006578	940/359	6,130 lm	5,770 lm	1,050 mA	31.8 V	37.6 V	36.8 W	167 lm/W	160 lm/W	>90
SLE 17mm 5000lm – Operating mode HO at 1,400 mA											
SLE 17mm 5000lm 930 PW R EXC8+	28006576	930/359	–	7,338 lm	1,400 mA	32.8 V	38.8 V	–	–	148 lm/W	>90
SLE 17mm 5000lm 935 PW R EXC8+	28006577	935/359	–	7,240 lm	1,400 mA	32.8 V	38.8 V	–	–	146 lm/W	>90
SLE 17mm 5000lm 940 PW R EXC8+	28006578	940/359	–	7,497 lm	1,400 mA	32.8 V	38.8 V	–	–	151 lm/W	>90
SLE 21mm 6000lm – Operating mode HE at 900 mA											
SLE 21mm 6000lm 930 PW R EXC8+	28006583	930/359	–	5,178 lm	900 mA	30.6 V	36.1 V	–	–	174 lm/W	>90
SLE 21mm 6000lm 935 PW R EXC8+	28006584	935/359	–	5,107 lm	900 mA	30.6 V	36.1 V	–	–	172 lm/W	>90
SLE 21mm 6000lm 940 PW R EXC8+	28006585	940/359	–	5,290 lm	900 mA	30.6 V	36.1 V	–	–	178 lm/W	>90
SLE 21mm 6000lm – Operating mode NM at 1,400 mA											
SLE 21mm 6000lm 930 PW R EXC8+	28006583	930/359	8,320 lm	7,832 lm	1,400 mA	31.7 V	37.5 V	48.8 W	171 lm/W	163 lm/W	>90
SLE 21mm 6000lm 935 PW R EXC8+	28006584	935/359	8,205 lm	7,724 lm	1,400 mA	31.7 V	37.5 V	48.8 W	168 lm/W	161 lm/W	>90
SLE 21mm 6000lm 940 PW R EXC8+	28006585	940/359	8,500 lm	8,001 lm	1,400 mA	31.7 V	37.5 V	48.8 W	174 lm/W	167 lm/W	>90
SLE 21mm 6000lm – Operating mode HO at 2,100 mA											
SLE 21mm 6000lm 930 PW R EXC8+	28006583	930/359	–	11,324 lm	2,100 mA	33.1 V	39.1 V	–	–	151 lm/W	>90
SLE 21mm 6000lm 935 PW R EXC8+	28006584	935/359	–	11,168 lm	2,100 mA	33.1 V	39.1 V	–	–	149 lm/W	>90
SLE 21mm 6000lm 940 PW R EXC8+	28006585	940/359	–	11,569 lm	2,100 mA	33.1 V	39.1 V	–	–	154 lm/W	>90

① See derating curves in data sheet section 2.3.

② If mounted with M3 screws (screw thread Ø3 mm, screw head Ø6 mm) and plastic washers with 0.5 mm thickness.

③ Tolerance of useful light flux - 0 % / + 15 %. Measurement uncertainty ± 10 %.

④ Tolerance of expected light flux - 0 % / + 15 %. Measurement uncertainty ± 10 %. Based on calculation.

⑤ Tolerance of power consumption P_{on} ± 10 %. Measurement uncertainty ± 5 %.

Housing for SLE

Accessory

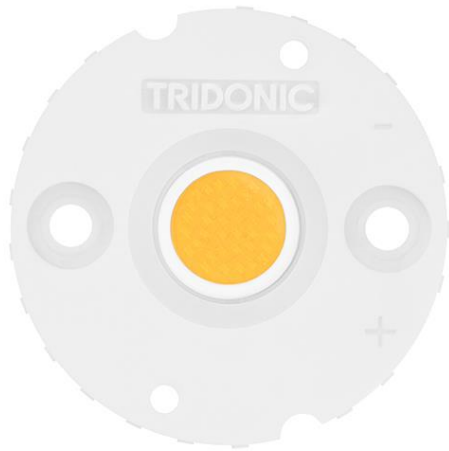

Product description

- _ Housing for SLE
- _ Diameter: 35 mm
- _ Material: Lexan Resin 943
- _ M3 screws with flat head, max. head diameter of 6 mm and max. torque for fixing is 0.5 Nm

Website

<http://www.tridonic.com/28003024>



LES09

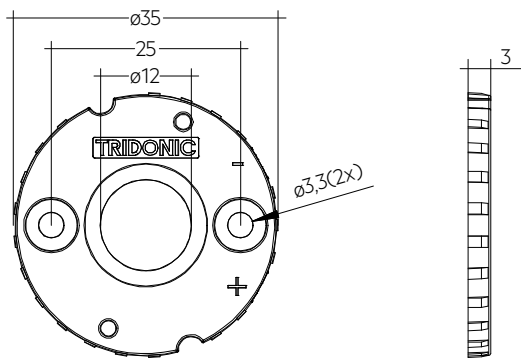

SLE G7 HOUSING LES09

Ordering data

Type	Article number	Packaging, bag	Weight per pc.
SLE G7 HOUSING LES 09	28003024	500 pc(s).	0.002 kg

1. Standards

EN 62031
EN 62471
UL 8750
IEC 62778

1.2 Photometric code

Key for photometric code, e. g. 830 / 359

1 st digit	2 nd + 3 rd digit	4 th digit	5 th digit	6 th digit
Code CRI	Colour temperature in Kelvin x 100	MacAdam initial	MacAdam after 25% of the lifetime (max.6000h)	Luminous flux after 25% of the lifetime (max.6000h)
7 70 – 79				Code Luminous flux
8 80 – 89				7 ≥ 70 %
9 ≥90				8 ≥ 80 % 9 ≥ 90 %

1.3 Energy classification

Type	Colour temperature	Forward current	Energy classification	Energy consumption
SLE 09mm – 2600lm				
SLE 09mm 2600lm 930 PW R EXC8+	3,000 K	500 mA	D	18 kWh / 1,000 h
SLE 09mm 2600lm 935 PW R EXC8+	3,500 K	500 mA	D	18 kWh / 1,000 h
SLE 09mm 2600lm 940 PW R EXC8+	4,000 K	500 mA	D	18 kWh / 1,000 h
SLE 13mm – 3000lm				
SLE 13mm 3000lm 930 PW R EXC8+	3,000 K	600 mA	D	22 kWh / 1,000 h
SLE 13mm 3000lm 935 PW R EXC8+	3,500 K	600 mA	D	22 kWh / 1,000 h
SLE 13mm 3000lm 940 PW R EXC8+	4,000 K	600 mA	D	22 kWh / 1,000 h
SLE 15mm – 4000lm				
SLE 15mm 4000lm 930 PW R EXC8+	3,000 K	800 mA	D	28 kWh / 1,000 h
SLE 15mm 4000lm 935 PW R EXC8+	3,500 K	800 mA	D	28 kWh / 1,000 h
SLE 15mm 4000lm 940 PW R EXC8+	4,000 K	800 mA	D	28 kWh / 1,000 h
SLE 17mm – 5000lm				
SLE 17mm 5000lm 930 PW R EXC8+	3,000 K	1,050 mA	D	37 kWh / 1,000 h
SLE 17mm 5000lm 935 PW R EXC8+	3,500 K	1,050 mA	D	37 kWh / 1,000 h
SLE 17mm 5000lm 940 PW R EXC8+	4,000 K	1,050 mA	D	37 kWh / 1,000 h
SLE 21mm – 6000lm				
SLE 21mm 6000lm 930 PW R EXC8+	3,000 K	1,400 mA	D	49 kWh / 1,000 h
SLE 21mm 6000lm 935 PW R EXC8+	3,500 K	1,400 mA	D	49 kWh / 1,000 h
SLE 21mm 6000lm 940 PW R EXC8+	4,000 K	1,400 mA	C	49 kWh / 1,000 h

Energy label and further information at www.tridonic.com in the certificates tab of the corresponding product page and at the EPREL data base <https://eprel.ec.europa.eu/>

2. Thermal details

2.1 tp point, ambient temperature and lifetime

The temperature at tp reference point is crucial for the light output and lifetime of a LED product.

For SLE EXC8+ a tp temperature of 65 °C has to be complied in order to achieve an optimum between heat sink requirements, light output and lifetime.

Compliance with the maximum permissible reference temperature at the tp point must be checked under operating conditions in a thermally stable state. The maximum value must be determined under worst-case conditions for the relevant application.

The tc and tp temperature of LED modules from Tridonic are measured at the same reference point.

To check the tc / tp temperature, the temperature sensor has to be mounted on one of both contact pads at the marked position as stated in the drawing.

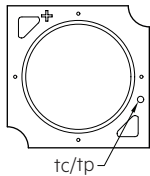

2.2 Storage and humidity

storage temperature	-40...+95 °C
---------------------	--------------

Operation only in dry environment with a relative humidity lower than 60 %. The module needs to be soldered within 24 hours after opening the ESD packaging. Humidity during processing should be between 30 to 60 %. Unused modules must be stored in waterproof packages.

2.3 Derating curves

SLE 09mm 2600lm

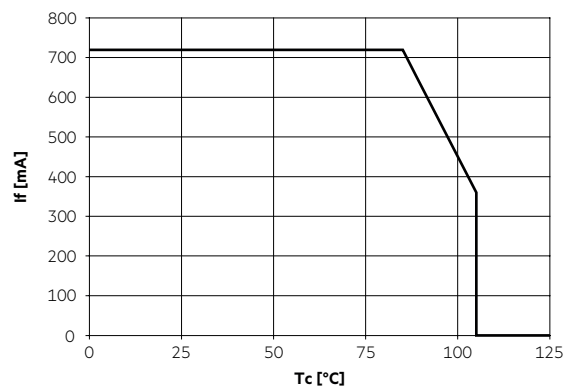

SLE 13mm 3000lm

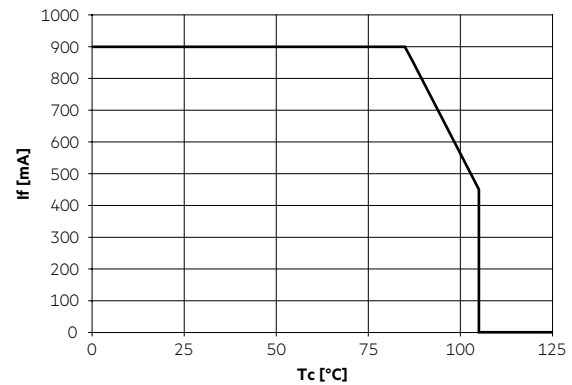

SLE 15mm 4000lm

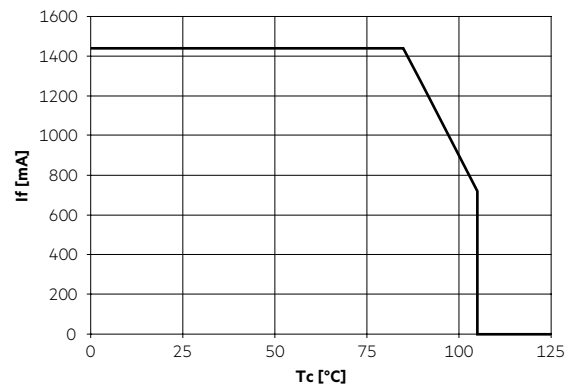

SLE 17mm 5000lm

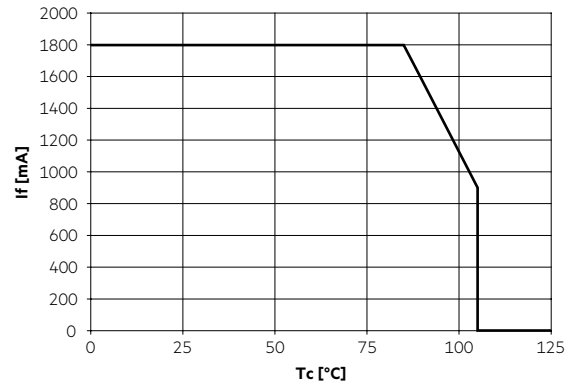

SLE 21mm 6000lm

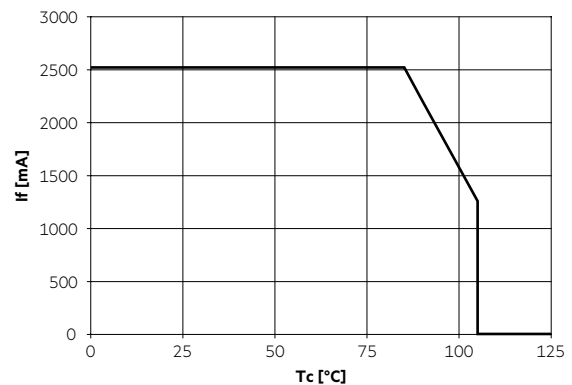

2.4 Thermal design and heat sink

The rated life of LED products depends to a large extent on the temperature. If the permissible temperature limits are exceeded, the life of the SLE will be greatly reduced or the SLE may be destroyed.

2.5 Heat sink values

SLE 09mm 2600lm

ta	tp	Operating current	R _{th, hs-a}	Cooling area
25°C	65°C	300 mA	6.98 K/W	96 cm ²
35°C	65°C		5.23 K/W	128 cm ²
40°C	65°C		4.35 K/W	153 cm ²
45°C	65°C		3.48 K/W	192 cm ²
50°C	65°C		2.60 K/W	256 cm ²
55°C	65°C		1.73 K/W	386 cm ²
60°C	65°C	0.85 K/W	781 cm ²	
25°C	65°C	500 mA	3.71 K/W	180 cm ²
35°C	65°C		2.77 K/W	240 cm ²
40°C	65°C		2.31 K/W	289 cm ²
45°C	65°C		1.84 K/W	362 cm ²
50°C	65°C		1.38 K/W	484 cm ²
55°C	65°C		0.91 K/W	732 cm ²
60°C	65°C	0.44 K/W	1,500 cm ²	
25°C	65°C	650 mA	2.62 K/W	255 cm ²
35°C	65°C		1.96 K/W	341 cm ²
40°C	65°C		1.63 K/W	410 cm ²
45°C	65°C		1.30 K/W	514 cm ²
50°C	65°C		0.97 K/W	689 cm ²
55°C	65°C		0.64 K/W	1,045 cm ²
60°C	65°C	0.31 K/W	2,162 cm ²	

SLE 13mm 3000lm

ta	tp	Operating current	R _{th, hs-a}	Cooling area
25°C	65°C	350 mA	6.30 K/W	106 cm ²
35°C	65°C		4.72 K/W	141 cm ²
40°C	65°C		3.93 K/W	169 cm ²
45°C	65°C		3.14 K/W	212 cm ²
50°C	65°C		2.36 K/W	283 cm ²
55°C	65°C		1.57 K/W	425 cm ²
60°C	65°C	0.78 K/W	857 cm ²	
25°C	65°C	600 mA	3.19 K/W	209 cm ²
35°C	65°C		2.39 K/W	279 cm ²
40°C	65°C		1.99 K/W	336 cm ²
45°C	65°C		1.59 K/W	420 cm ²
50°C	65°C		1.19 K/W	561 cm ²
55°C	65°C		0.79 K/W	846 cm ²
60°C	65°C	0.39 K/W	1,715 cm ²	
25°C	65°C	800 mA	2.16 K/W	309 cm ²
35°C	65°C		1.62 K/W	412 cm ²
40°C	65°C		1.35 K/W	495 cm ²
45°C	65°C		1.07 K/W	621 cm ²
50°C	65°C		0.80 K/W	830 cm ²
55°C	65°C		0.53 K/W	1,254 cm ²
60°C	65°C	0.26 K/W	2,560 cm ²	

SLE 15mm 4000lm

ta	tp	Operating current	R _{th, hs-a}	Cooling area
25°C	65°C	500 mA	4.46 K/W	149 cm ²
35°C	65°C		3.34 K/W	199 cm ²
40°C	65°C		2.78 K/W	239 cm ²
45°C	65°C		2.23 K/W	300 cm ²
50°C	65°C		1.67 K/W	400 cm ²
55°C	65°C		1.11 K/W	602 cm ²
60°C	65°C	0.55 K/W	1,216 cm ²	
25°C	65°C	800 mA	2.51 K/W	266 cm ²
35°C	65°C		1.88 K/W	355 cm ²
40°C	65°C		1.56 K/W	426 cm ²
45°C	65°C		1.25 K/W	534 cm ²
50°C	65°C		0.93 K/W	713 cm ²
55°C	65°C		0.62 K/W	1,076 cm ²
60°C	65°C	0.30 K/W	2,191 cm ²	
25°C	65°C	1,050 mA	1.98 K/W	336 cm ²
35°C	65°C		1.49 K/W	449 cm ²
40°C	65°C		1.24 K/W	539 cm ²
45°C	65°C		0.99 K/W	676 cm ²
50°C	65°C		0.74 K/W	904 cm ²
55°C	65°C		0.49 K/W	1,367 cm ²
60°C	65°C	0.24 K/W	2,796 cm ²	

SLE 17mm 5000lm

ta	tp	Operating current	R _{th, hs-a}	Cooling area
25°C	65°C	700 mA	3.58 K/W	186 cm ²
35°C	65°C		2.68 K/W	249 cm ²
40°C	65°C		2.23 K/W	299 cm ²
45°C	65°C		1.79 K/W	373 cm ²
50°C	65°C		1.34 K/W	498 cm ²
55°C	65°C		0.89 K/W	749 cm ²
60°C	65°C	0.44 K/W	1,506 cm ²	
25°C	65°C	1,050 mA	2.12 K/W	315 cm ²
35°C	65°C		1.59 K/W	420 cm ²
40°C	65°C		1.32 K/W	504 cm ²
45°C	65°C		1.06 K/W	631 cm ²
50°C	65°C		0.79 K/W	843 cm ²
55°C	65°C		0.53 K/W	1,268 cm ²
60°C	65°C	0.26 K/W	2,561 cm ²	
25°C	65°C	1,400 mA	1.45 K/W	460 cm ²
35°C	65°C		1.09 K/W	614 cm ²
40°C	65°C		0.90 K/W	737 cm ²
45°C	65°C		0.72 K/W	923 cm ²
50°C	65°C		0.54 K/W	1,233 cm ²
55°C	65°C		0.36 K/W	1,858 cm ²
60°C	65°C	0.18 K/W	3,769 cm ²	

SLE 21mm 6000lm

ta	tp	Operating current	R _{th, hs-a}	Cooling area
25 °C	65 °C	900 mA	2.50 K/W	267 cm ²
35 °C	65 °C		1.87 K/W	356 cm ²
40 °C	65 °C		1.56 K/W	427 cm ²
45 °C	65 °C		1.25 K/W	534 cm ²
50 °C	65 °C		0.93 K/W	713 cm ²
55 °C	65 °C		0.62 K/W	1,073 cm ²
60 °C	65 °C	0.31 K/W	2,163 cm ²	
25 °C	65 °C	1,400 mA	1.45 K/W	459 cm ²
35 °C	65 °C		1.09 K/W	612 cm ²
40 °C	65 °C		0.91 K/W	735 cm ²
45 °C	65 °C		0.72 K/W	921 cm ²
50 °C	65 °C		0.54 K/W	1,230 cm ²
55 °C	65 °C		0.36 K/W	1,854 cm ²
60 °C	65 °C	0.18 K/W	3,760 cm ²	
25 °C	65 °C	2,100 mA	0.47 K/W	1,412 cm ²
35 °C	65 °C		0.35 K/W	1,890 cm ²
40 °C	65 °C		0.29 K/W	2,274 cm ²
45 °C	65 °C		0.23 K/W	2,855 cm ²
50 °C	65 °C		0.17 K/W	3,834 cm ²
55 °C	65 °C		0.11 K/W	5,835 cm ²
60 °C	65 °C	0.05 K/W	12,203 cm ²	

Notes

The actual cooling can differ because of the material, the structural shape, outside influences and the installation situation. A thermal connection between SLE and heat sink with heat-conducting paste or heat conducting adhesive film is absolutely necessary.

Additionally the SLE has to be fixed on the heat sink with M3 screws to optimise the thermal connection.

Use of thermal interface material with thermal conductivity of $\lambda > 1 \text{ W/mK}$ and layer thickness of interface material with max. 50 μm or a similar interface material where the quotient of layer thickness and thermal conductivity $b < 50 \mu\text{mmK/W}$.

3. Installation / wiring

3.1 Electrical supply/choice of LED driver

SLE from Tridonic are not protected against overvoltages, overcurrents, overloads or short-circuit currents. Safe and reliable operation can only be guaranteed in conjunction with a LED driver which complies with the relevant standards. The use of LED drivers from Tridonic in combination with SLE guarantees the necessary protection for safe and reliable operation.

If a LED driver other than Tridonic is used, it must provide the following protection:

- Short-circuit protection
- Overload protection
- Overtemperature protection



SLE must be supplied by a constant current LED driver. Operation with a constant voltage LED driver will lead to an irreversible damage of the module. Wrong polarity can damage the SLE.



SLE must not be operated with nonSELV LED driver.



SLE are basic insulated up to 60 V SELV against ground and can be mounted directly on earthed metal parts of the luminaire. If the max. output voltage of the LED driver (also against earth) is above 60 V SELV, an additional insulation between LED module and heat sink is required (for example by insulated thermal pads) or by a suitable luminaire construction.

At voltages > 60 V an additional protection against direct touch (test finger) to the light emitting side of the module has to be guaranteed. This is typically achieved by means of a non removable light distributor over the module.

3.2 Wiring

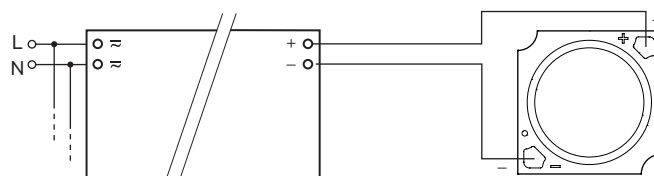

Driver LC ...

3.3 Soldering guidelines



The modules are suitable only for manual soldering (max. 350 °C, 3 seconds).

3.4 Mounting instruction



SLE from Tridonic which have to be installed on a heat sink have to be connected with heat-conducting paste or heat conducting adhesive film and fixed with M3 screws and washer.

The fixing/cooling surface must be cleaned by removing all dirt, dust and grease before installing the LED modules.

None of the components of the SLE (substrate, LED, electronic components etc.) may be exposed to tensile or compressive stresses.



Torque for fixing: 0.3 – 0.5 Nm



Chemical substance may harm the LED module. Chemical reactions could lead to colour shift, reduced luminous flux or a total failure of the module caused by corrosion of electrical connections.

Materials which are used in LED applications (e.g. sealings, adhesives) must not produce dissolver gas. They must not be condensation curing based, acetate curing based or contain sulfur, chlorine or phthalate.

Avoid corrosive atmosphere during usage and storage.

3.5 EOS/ESD safety guidelines



The device / module contains components that are sensitive to electrostatic discharge and may only be installed in the factory and on site if appropriate EOS/ESD protection measures have been taken. No special measures need be taken for devices/modules with enclosed casings (contact with the pc board not possible), just normal installation practice.

For further information for EOS/ESD safety guidelines and the ESD classification please refer to the brochure entitled <http://www.tridonic.com/esd-protection>.

4. Lifetime

4.1 Lifetime, lumen maintenance and failure rate

The light output of an LED module decreases over the lifetime, this is characterized with the L value. L70 means that the LED module will give 70 % of its initial luminous flux. This value is always related to the number of operation hours and therefore defines the lifetime of an LED module.

As the L value is a statistical value and the lumen maintenance may vary over the delivered LED modules. The B value defines the amount of modules which are below the specific L value, e.g. L70B10 means 10 % of the LED modules are below 70 % of the initial luminous flux, respectively 90 % will be above 70 % of the initial value.

In addition the percentage of failed modules (fatal failure) is characterized by the C value.

The F value is the combination of the B and C value. That means for F degradation and complete failures are considered, e.g. L70F10 means 10 % of the LED modules may fail or be below 70 % of the initial luminous flux.

4.2 Lumen maintenance

SLE 09mm 2600lm

Operating current	tp temperature	L90 / B10	L90 / B50	L80 / B10	L80 / B50	L70 / B10	L70 / B50
300 mA	60 °C	>100k h	>100k h	>100k h	>100k h	>100k h	>100k h
	70 °C	>100k h	>100k h	>100k h	>100k h	>100k h	>100k h
	85 °C	>100k h	>100k h	>100k h	>100k h	>100k h	>100k h
	95 °C	>100k h	>100k h	>100k h	>100k h	>100k h	>100k h
500 mA	60 °C	>100k h	>100k h	>100k h	>100k h	>100k h	>100k h
	70 °C	>100k h	>100k h	>100k h	>100k h	>100k h	>100k h
	85 °C	>100k h	>100k h	>100k h	>100k h	>100k h	>100k h
	95 °C	>100k h	>100k h	>100k h	>100k h	>100k h	>100k h
650 mA	60 °C	>100k h	>100k h	>100k h	>100k h	>100k h	>100k h
	70 °C	>100k h	>100k h	>100k h	>100k h	>100k h	>100k h
	85 °C	>100k h	>100k h	>100k h	>100k h	>100k h	>100k h
	95 °C	>100k h	>100k h	>100k h	>100k h	>100k h	>100k h

SLE 13mm 3000lm

Operating current	tp temperature	L90 / B10	L90 / B50	L80 / B10	L80 / B50	L70 / B10	L70 / B50
350 mA	60 °C	>100k h	>100k h	>100k h	>100k h	>100k h	>100k h
	70 °C	>100k h	>100k h	>100k h	>100k h	>100k h	>100k h
	85 °C	>100k h	>100k h	>100k h	>100k h	>100k h	>100k h
	95 °C	>100k h	>100k h	>100k h	>100k h	>100k h	>100k h
600 mA	60 °C	>100k h	>100k h	>100k h	>100k h	>100k h	>100k h
	70 °C	>100k h	>100k h	>100k h	>100k h	>100k h	>100k h
	85 °C	>100k h	>100k h	>100k h	>100k h	>100k h	>100k h
	95 °C	>100k h	>100k h	>100k h	>100k h	>100k h	>100k h
800 mA	60 °C	>100k h	>100k h	>100k h	>100k h	>100k h	>100k h
	70 °C	>100k h	>100k h	>100k h	>100k h	>100k h	>100k h
	85 °C	>100k h	>100k h	>100k h	>100k h	>100k h	>100k h
	95 °C	>100k h	>100k h	>100k h	>100k h	>100k h	>100k h

SLE 15mm 4000lm

Operating current	tp temperature	L90 / B10	L90 / B50	L80 / B10	L80 / B50	L70 / B10	L70 / B50
500 mA	60 °C	>100k h	>100k h	>100k h	>100k h	>100k h	>100k h
	70 °C	>100k h	>100k h	>100k h	>100k h	>100k h	>100k h
	85 °C	>100k h	>100k h	>100k h	>100k h	>100k h	>100k h
	95 °C	>100k h	>100k h	>100k h	>100k h	>100k h	>100k h
800 mA	60 °C	>100k h	>100k h	>100k h	>100k h	>100k h	>100k h
	70 °C	>100k h	>100k h	>100k h	>100k h	>100k h	>100k h
	85 °C	>100k h	>100k h	>100k h	>100k h	>100k h	>100k h
	95 °C	>100k h	>100k h	>100k h	>100k h	>100k h	>100k h
1,050 mA	60 °C	>100k h	>100k h	>100k h	>100k h	>100k h	>100k h
	70 °C	>100k h	>100k h	>100k h	>100k h	>100k h	>100k h
	85 °C	>100k h	>100k h	>100k h	>100k h	>100k h	>100k h
	95 °C	>100k h	>100k h	>100k h	>100k h	>100k h	>100k h

SLE 17mm 5000lm

Operating current	tp temperature	L90 / B10	L90 / B50	L80 / B10	L80 / B50	L70 / B10	L70 / B50
700 mA	60 °C	>100k h	>100k h	>100k h	>100k h	>100k h	>100k h
	70 °C	>100k h	>100k h	>100k h	>100k h	>100k h	>100k h
	85 °C	>100k h	>100k h	>100k h	>100k h	>100k h	>100k h
	95 °C	>100k h	>100k h	>100k h	>100k h	>100k h	>100k h
1,050 mA	60 °C	>100k h	>100k h	>100k h	>100k h	>100k h	>100k h
	70 °C	>100k h	>100k h	>100k h	>100k h	>100k h	>100k h
	85 °C	>100k h	>100k h	>100k h	>100k h	>100k h	>100k h
1,400 mA	60 °C	>100k h	>100k h	>100k h	>100k h	>100k h	>100k h
	70 °C	>100k h	>100k h	>100k h	>100k h	>100k h	>100k h
	85 °C	>100k h	>100k h	>100k h	>100k h	>100k h	>100k h
	95 °C	>100k h	>100k h	>100k h	>100k h	>100k h	>100k h

SLE 21mm 6000lm

Operating current	tp temperature	L90 / B10	L90 / B50	L80 / B10	L80 / B50	L70 / B10	L70 / B50
900 mA	60 °C	>100k h	>100k h	>100k h	>100k h	>100k h	>100k h
	70 °C	>100k h	>100k h	>100k h	>100k h	>100k h	>100k h
	85 °C	>100k h	>100k h	>100k h	>100k h	>100k h	>100k h
	95 °C	>100k h	>100k h	>100k h	>100k h	>100k h	>100k h
1,400 mA	60 °C	>100k h	>100k h	>100k h	>100k h	>100k h	>100k h
	70 °C	>100k h	>100k h	>100k h	>100k h	>100k h	>100k h
	85 °C	>100k h	>100k h	>100k h	>100k h	>100k h	>100k h
	95 °C	>100k h	>100k h	>100k h	>100k h	>100k h	>100k h
2,100 mA	60 °C	>100k h	>100k h	>100k h	>100k h	>100k h	>100k h
	70 °C	>100k h	>100k h	>100k h	>100k h	>100k h	>100k h
	85 °C	>100k h	>100k h	>100k h	>100k h	>100k h	>100k h
	95 °C	>100k h	>100k h	>100k h	>100k h	>100k h	>100k h

L00C03 >100 kh. At Irated and tp rated, based on 10 switching cycles per day.

4.3 Switching capability

50,000 cycles

Test according to IEC 62717 Cl 10.3.3

30 s on / 30 s off at I_{max}

5. Electrical values

5.1 Declaration of electrical parameters

I_{rated} ... Nominal operating current the module is designed for.

I_{max} ... Max. permissible continuous operating current incl. The tolerances of the LED driver.

Max. permissible LF current ripple ... Max. output current of the LED driver incl. Tolerances and LF current ripple must not exceed this value.

Max. permissible peak current ... The max. output peak current of the LED driver must not exceed this value.

5.2 Typ. forward voltage vs. forward current

SLE 09mm 2600lm

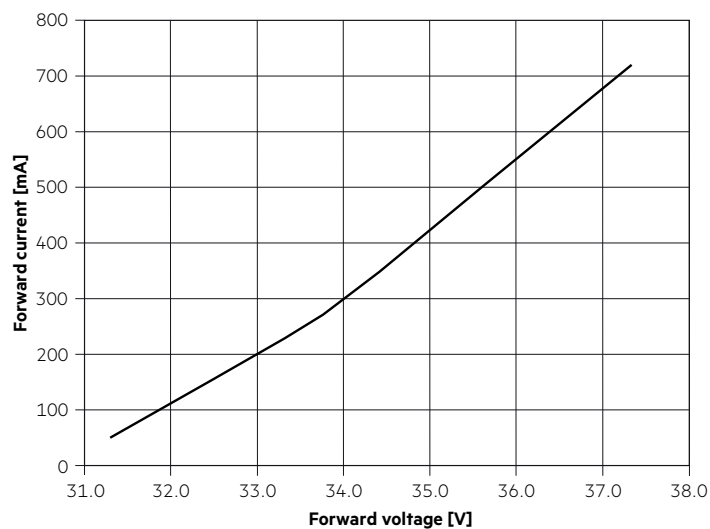

SLE 15mm 4000lm

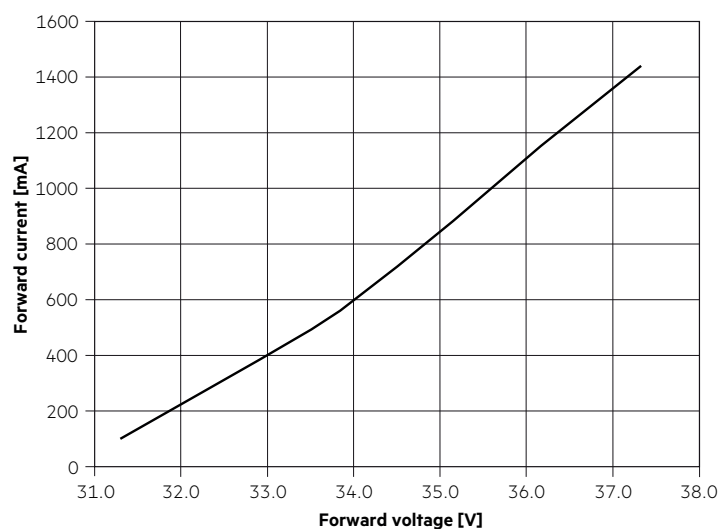

SLE 13mm 3000lm

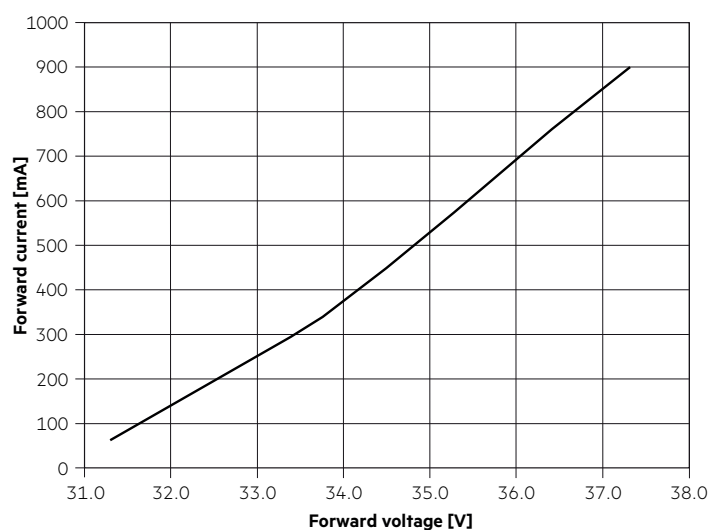

SLE 17mm 5000lm

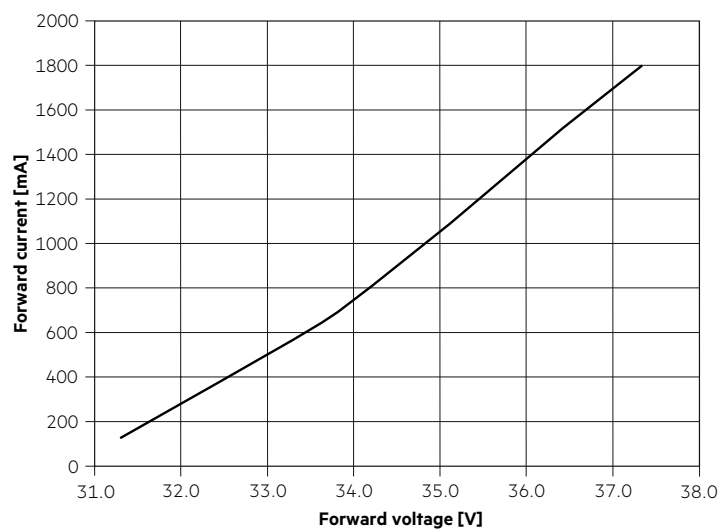

SLE 21mm 6000lm

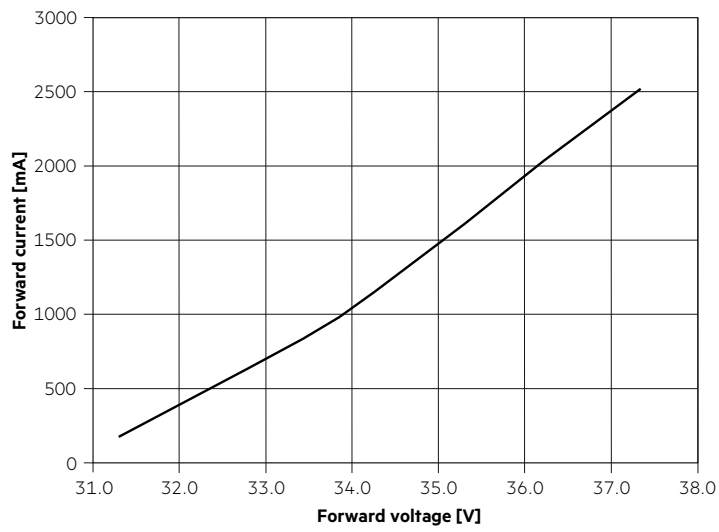

5.3 Forward voltage vs. tp temperature

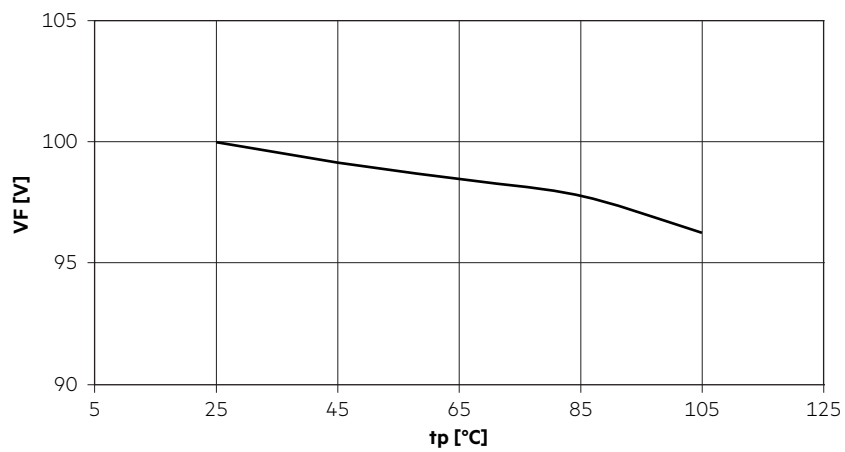

The diagrams based on statistic values.
The real values can be different.

6. Photometric characteristics

6.1 Coordinates and tolerances according to CIE 1931 and colour rendering

The specified colour coordinates are measured integral after a settling time of 50 ms. The current impuls depends on the module type. The ambient temperature of the measurement is $t_a = 25\text{ }^\circ\text{C}$. The measurement tolerance of the colour coordinates are ± 0.005 .

Module type	Current impulse
SLE 09mm 2600lm	500 mA
SLE 13mm 3000lm	600 mA
SLE 15mm 4000lm	800 mA
SLE 17mm 5000lm	1050 mA
SLE 21mm 6000lm	1400 mA

3,000 K – CRI90

	x0	y0
Centre	0.4188	0.3925

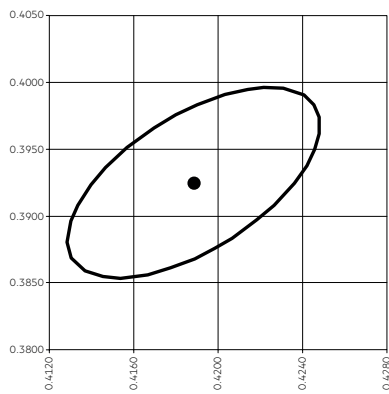

MacAdam ellipse: 3SDCM

TM30		CRI	
Rf	Rg	Ra	R9
91	101	94	67

Colour vector graphic

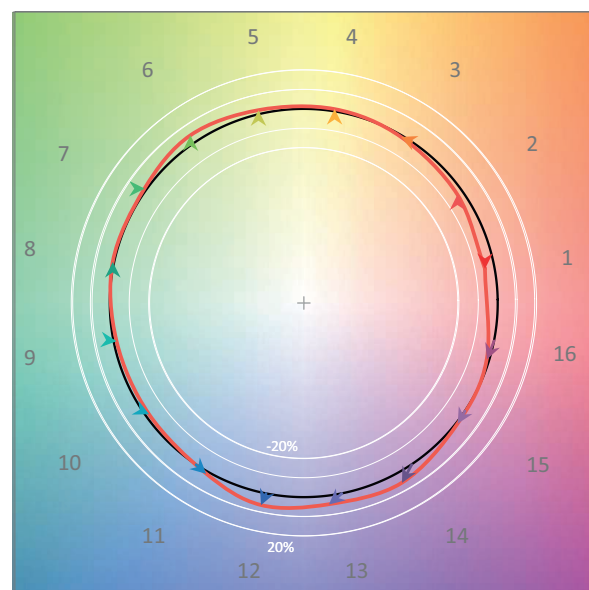

— Reference source
 — Test source

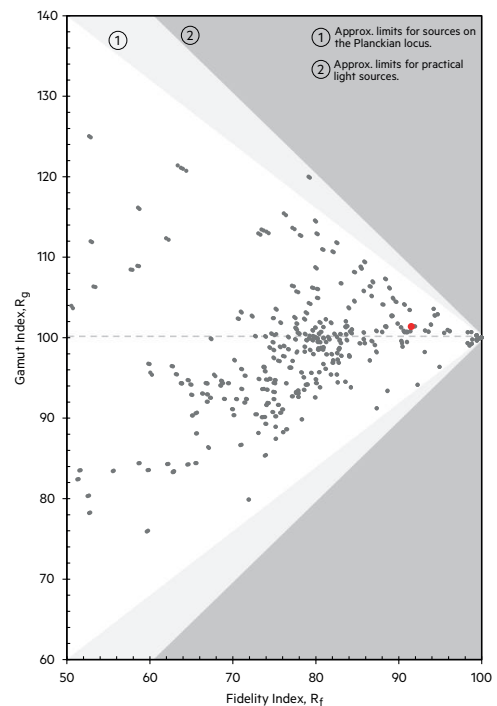
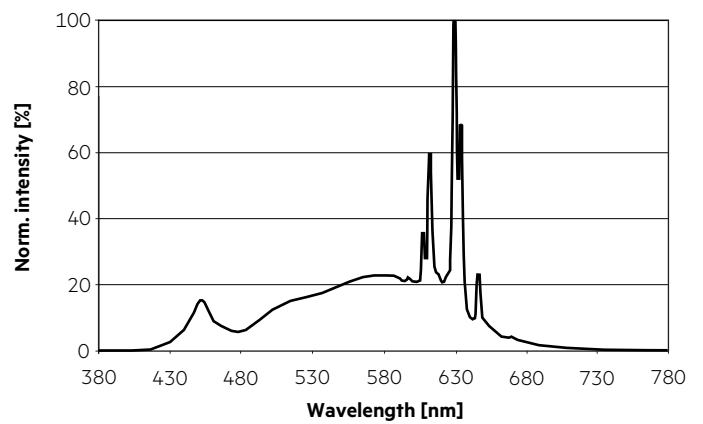

3,500 K - CRI90

	x0	y0
Centre	0.3924	0.3744

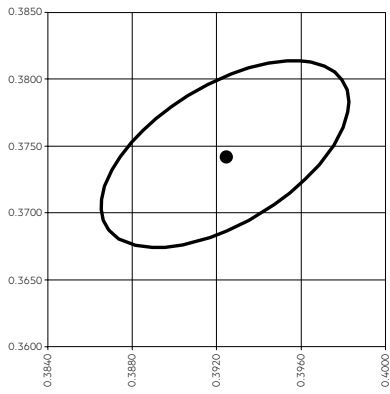

MacAdam ellipse: 3SDCM

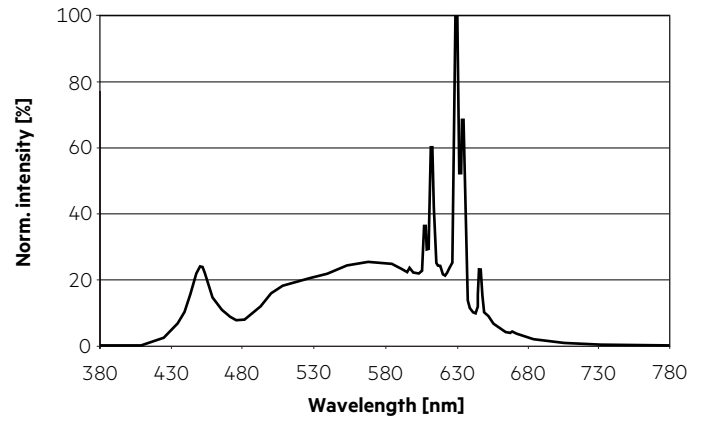

TM30		CRI	
Rf	Rg	Ra	R9
90	102	94	71

Colour vector graphic

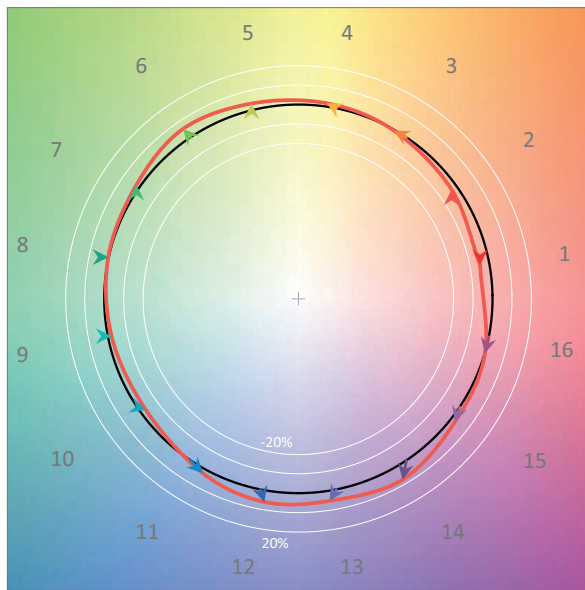

— Reference source
 — Test source

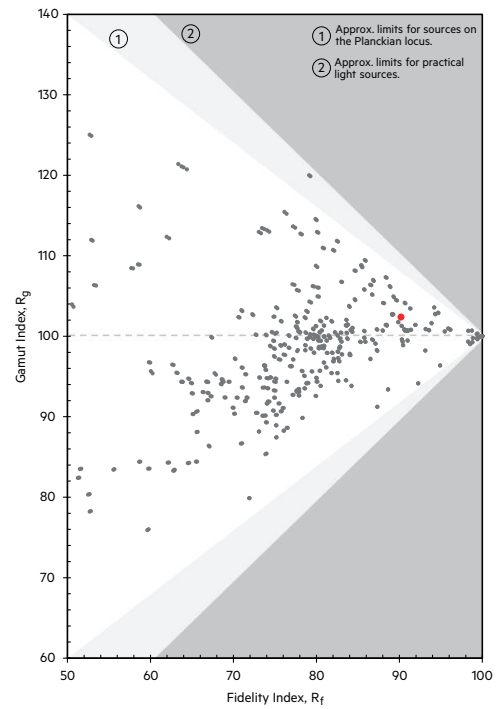

4,000 K – CRI90

	x0	y0
Centre	0.3706	0.3710

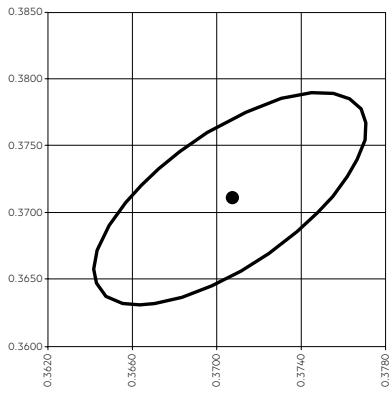

MacAdam ellipse: 3SDCM

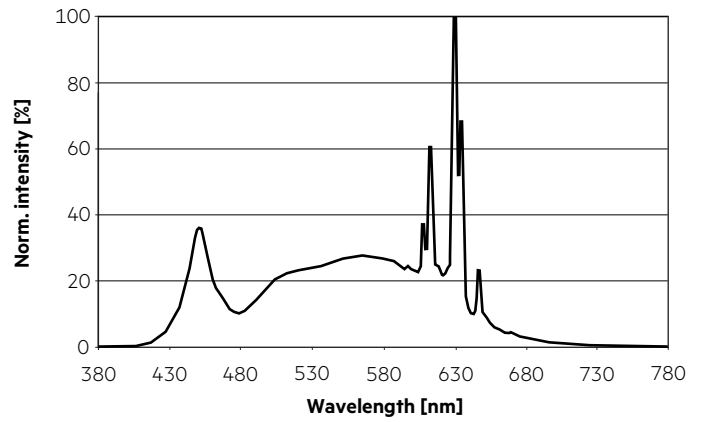

TM30		CRI	
Rf	Rg	Ra	R9
90	100	93	67

Colour vector graphic

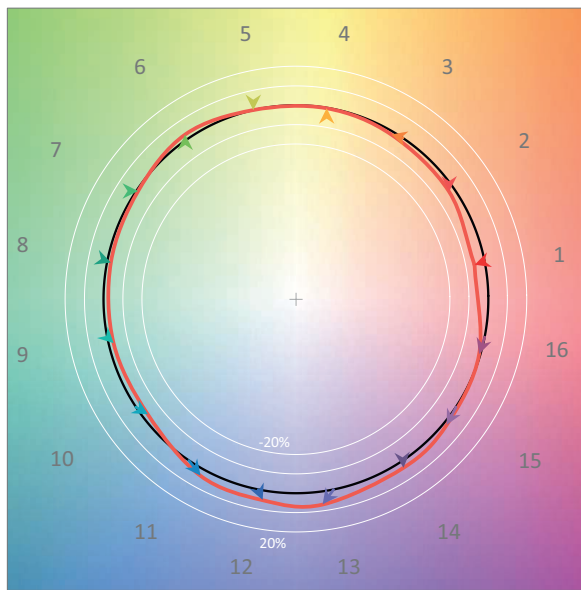

— Reference source
 — Test source

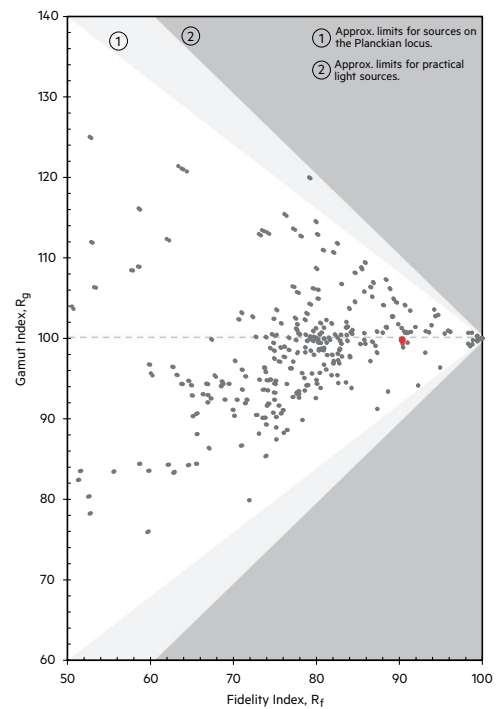

6.2 Light distribution

The optical design of the SLE product line ensures optimum homogeneity for the light distribution.

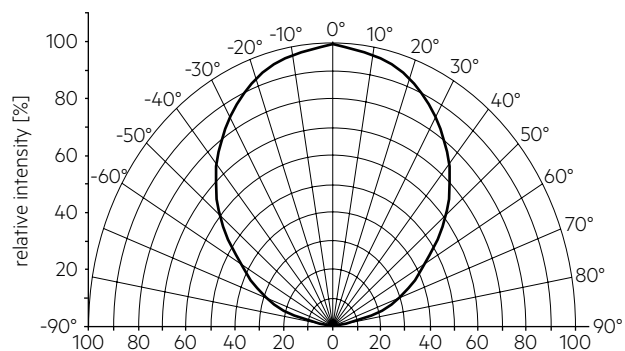

6.3 Relative luminous flux vs. tp temperature

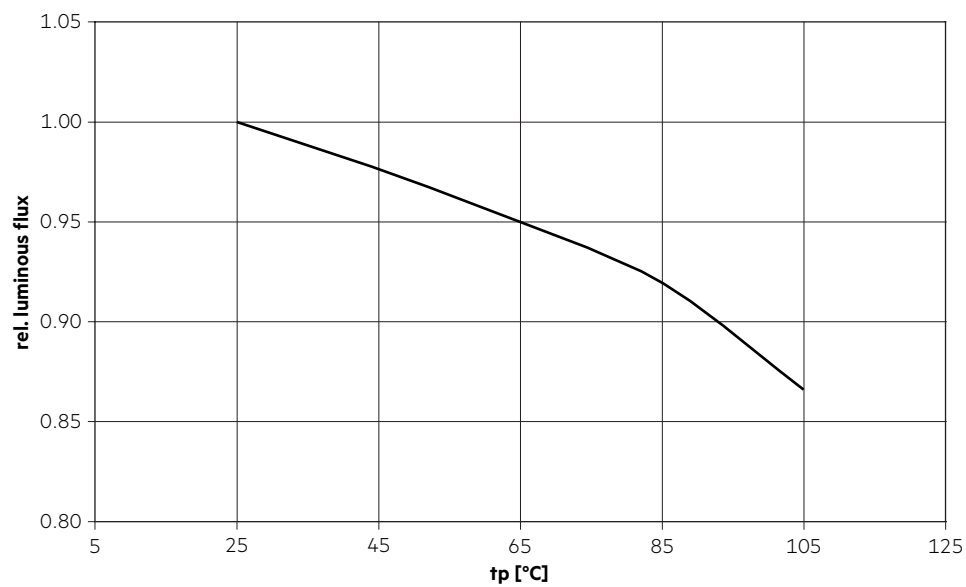

6.4 Relative luminous flux vs. operating current

SLE 09mm 2600lm

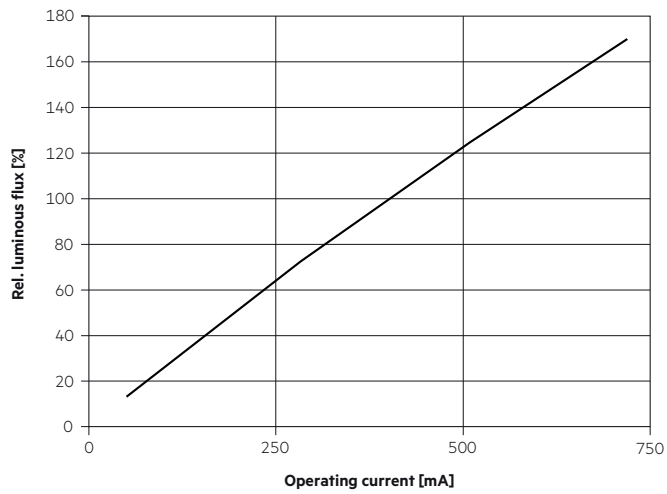

SLE 17mm 5000lm

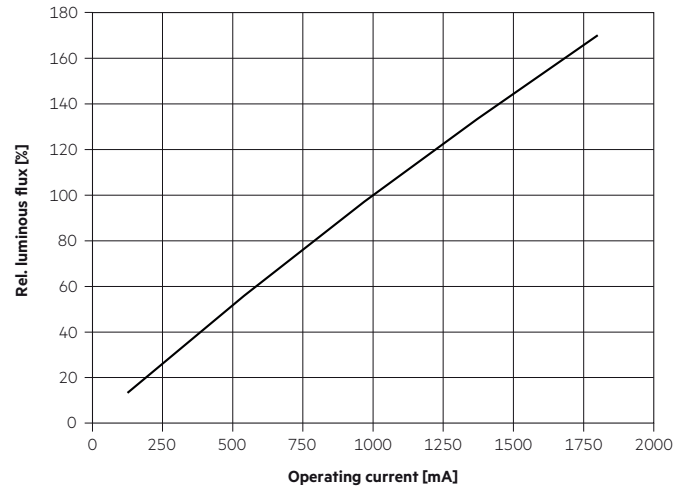

SLE 13mm 3000lm

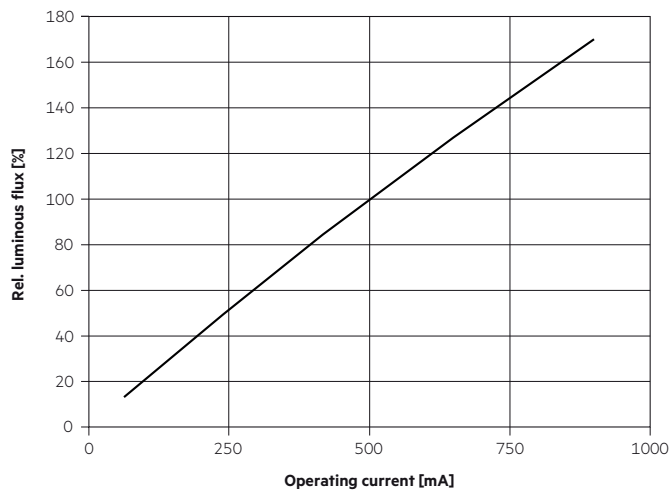

SLE 21mm 6000lm

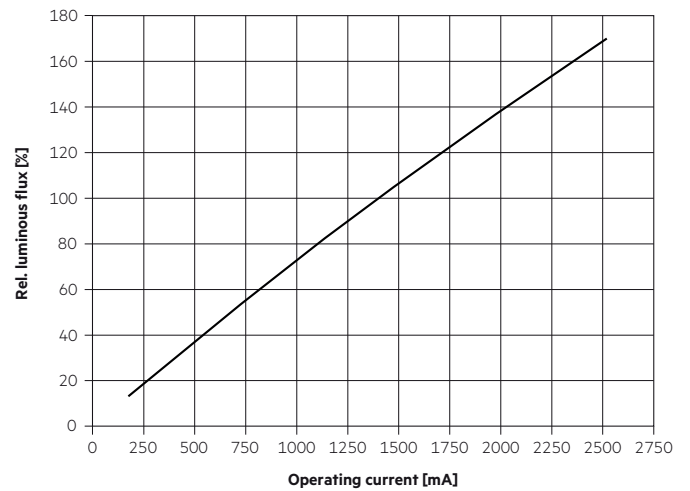

SLE 15mm 4000lm

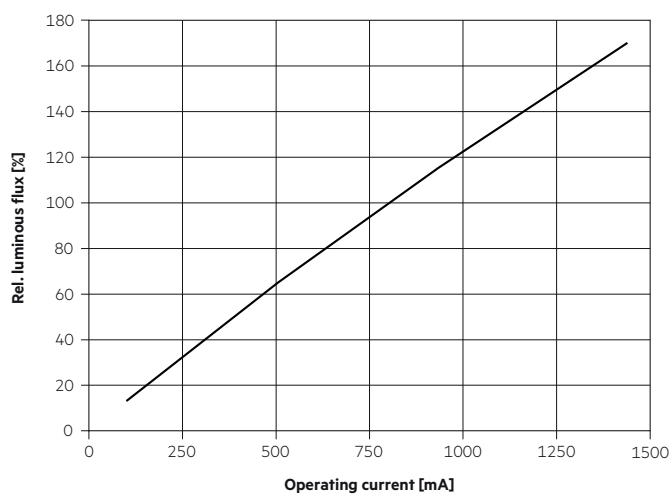

7. Miscellaneous

7.1 Additional information

Additional technical information at www.tridonic.com → Technical Data

Guarantee conditions at www.tridonic.com → Services

Lifetime declarations are informative and represent no warranty claim.

Colour rendering information are typical values and represent no warranty claim.