

Module RLE 2x6 EXC2 OTD Z19

Modules RLE excite



Product description

- _ High efficiency outdoor modules
- _ Suitable for harsh and humid outdoor conditions
- _ Tested acc. to salt spray test (IEC 60068-2-52) and harmful gas test (GR-1217-CORE)
- _ Huge performance temperature range from -40 ... +105 °C
- _ Surge tested (+/- to earth) 6 kV with Tridonic LED driver
- _ For use with IP6x lenses (e.g. LEDiL STRADA IP-2x6)
- _ Push-in terminals for simple and quick wiring
- _ HE ... High Efficiency, NM ... Nominal Mode, HO ... High Output
- _ Long lifetime up to 150,000 hours
- _ 8 years guarantee (conditions at <https://www.tridonic.com/en/int/services/manufacturer-guarantee-conditions>)

Optical properties

- _ Colour temperatures 3,000, 4,000 and 5,000 K
- _ Useful luminous flux 4,100 lm at Irated and tp = 25 °C
- _ Efficacy of the LED module 169 lm/W at Irated and tp = 25 °C
- _ Two colour rendering index to fit the application: CRI > 70 high efficiency, CRI > 80 for high colour rendering
- _ Small luminous flux tolerances ^①

Mechanical properties

- _ Module dimension 45 x 146 mm
- _ Installation of the module together with lens in the luminaire by means of an M3 screw

System solution

- _ Integrate compatible partner products into your final system solution:
<https://www.tridonic.com/en/int/products/accessories#partner>

^① Integral measurement over the complete module.

Website

<http://www.tridonic.com/28005820>



Linear



High bay



Decorative



Downlights



Spotlights



Free-standing



Area



Floor | Wall



Street

Module RLE 2x6 EXC2 OTD Z19

Modules RLE excite

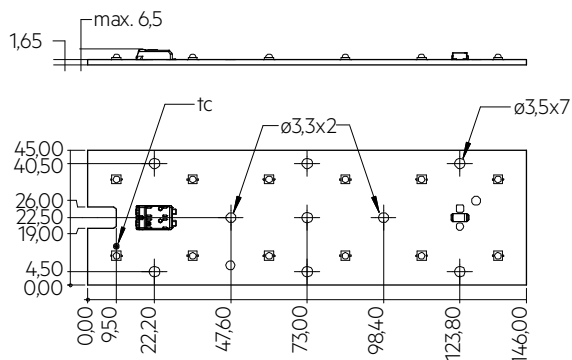

Ordering data

Type	Article number	Colour temperature	Packaging, carton	Weight per pc.
RLE 2x6 3000lm 730 HP EXC2 OTD Z19	28005820	3,000 K	50 pc(s).	0.028 kg
RLE 2x6 3000lm 740 HP EXC2 OTD Z19	28005819	4,000 K	50 pc(s).	0.028 kg
RLE 2x6 3000lm 750 HP EXC2 OTD Z19	28005821	5,000 K	50 pc(s).	0.028 kg
RLE 2x6 3000lm 830 HP EXC2 OTD	89603167	3,000 K	50 pc(s).	0.028 kg
RLE 2x6 3000lm 840 HP EXC2 OTD	89603168	4,000 K	50 pc(s).	0.028 kg
RLE 2x6 3000lm 850 HP EXC2 OTD	89603169	5,000 K	50 pc(s).	0.028 kg

Technical data

Beam characteristic	120°
Ambient temperature t_a	-40 ... +80 °C
t_p rated	75 °C
t_c	105 °C
I_{rated}	700 mA
I_{max}	1,200 mA
Max. permissible LF current ripple	1,320 mA
Max. permissible peak current	2,000 mA / max. 10 ms
Max. working voltage for insulation [®]	370 V
Max. working voltage for insulation with lens	670 V
Insulation test voltage	1,74 kV
CTI of the printed circuit board	> 600
Colour tolerance	5 SDCM
ESD classification	Severity level 4
Risk group (IEC 62471) [®]	RG2 (E _{thr} = 750 lx, RG1 at $d \geq 49$ cm)
Classification acc. to IEC 62031	Built-in
Type of protection	IPO0
Lumen maintenance L70B50	150,000 h
Guarantee (conditions at www.tridonic.com)	8 Year(s)

Approval marks



Standards

IEC 62031, IEC 62778, IEC 62471, IEC 61000-4-2, IEC 60068-2-52, UL 8750, GR-1217-CORE

Specific technical data

Type	Article number	Photometric code	Useful luminous flux at $t_p = 25\text{ °C}$ ^②	Expected luminous flux at t_p rated ^③	Typ. forward current	Min. forward voltage at t_p rated	Max. forward voltage at $t_p = 25\text{ °C}$	Power consumption P_{on} at $t_p = 25\text{ °C}$	Efficacy of the module at $t_p = 25\text{ °C}$	Expected efficacy of the module at t_p rated	Colour rendering index CRI
Operating mode HE											
RLE 2x6 3000lm 730 HP EXC2 OTD Z19	28005820	730/579	-	2,980 lm	500 mA	32.0 V	35.3 V	-	-	179 lm/W	>70
RLE 2x6 3000lm 740 HP EXC2 OTD Z19	28005819	740/579	-	3,150 lm	500 mA	32.0 V	35.3 V	-	-	190 lm/W	>70
RLE 2x6 3000lm 750 HP EXC2 OTD Z19	28005821	750/579	-	3,150 lm	500 mA	32.0 V	35.3 V	-	-	190 lm/W	>70
RLE 2x6 3000lm 830 HP EXC2 OTD	89603167	830/579	-	2,580 lm	500 mA	31.8 V	35.5 V	-	-	155 lm/W	>80
RLE 2x6 3000lm 840 HP EXC2 OTD	89603168	840/579	-	2,780 lm	500 mA	31.8 V	35.5 V	-	-	167 lm/W	>80
RLE 2x6 3000lm 850 HP EXC2 OTD	89603169	850/579	-	2,810 lm	500 mA	31.8 V	35.5 V	-	-	169 lm/W	>80
Operating mode NM											
RLE 2x6 3000lm 730 HP EXC2 OTD Z19	28005820	730/579	4,350 lm	4,090 lm	700 mA	32.6 V	35.9 V	24.3 W	160 lm/W	173 lm/W	>70
RLE 2x6 3000lm 740 HP EXC2 OTD Z19	28005819	740/579	4,350 lm	4,330 lm	700 mA	32.6 V	35.9 V	24.3 W	179 lm/W	183 lm/W	>70
RLE 2x6 3000lm 750 HP EXC2 OTD Z19	28005821	750/579	4,350 lm	4,330 lm	700 mA	32.6 V	35.9 V	24.3 W	179 lm/W	183 lm/W	>70
RLE 2x6 3000lm 830 HP EXC2 OTD	89603167	830/579	3,760 lm	3,540 lm	700 mA	32.4 V	36.1 V	24.3 W	155 lm/W	150 lm/W	>80
RLE 2x6 3000lm 840 HP EXC2 OTD	89603168	840/579	4,040 lm	3,810 lm	700 mA	32.4 V	36.1 V	24.3 W	166 lm/W	161 lm/W	>80
RLE 2x6 3000lm 850 HP EXC2 OTD	89603169	850/579	4,100 lm	3,860 lm	700 mA	32.4 V	36.1 V	24.3 W	169 lm/W	163 lm/W	>80
Operating mode HO											
RLE 2x6 3000lm 730 HP EXC2 OTD Z19	28005820	730/579	-	5,800 lm	1,050 mA	33.5 V	36.8 V	-	-	160 lm/W	>70
RLE 2x6 3000lm 740 HP EXC2 OTD Z19	28005819	740/579	-	6,140 lm	1,050 mA	33.5 V	36.8 V	-	-	169 lm/W	>70
RLE 2x6 3000lm 750 HP EXC2 OTD Z19	28005821	750/579	-	6,140 lm	1,050 mA	33.5 V	36.8 V	-	-	183 lm/W	>70
RLE 2x6 3000lm 830 HP EXC2 OTD	89603167	830/579	-	4,990 lm	1,050 mA	33.2 V	37.0 V	-	-	137 lm/W	>80
RLE 2x6 3000lm 840 HP EXC2 OTD	89603168	840/579	-	5,370 lm	1,050 mA	33.2 V	37.0 V	-	-	148 lm/W	>80
RLE 2x6 3000lm 850 HP EXC2 OTD	89603169	850/579	-	5,440 lm	1,050 mA	33.2 V	37.0 V	-	-	150 lm/W	>80

② If mounted with M3 screws.

③ Measured at I_{max} .

④ Tolerance of useful light flux - 0 % / + 15 %. Measurement uncertainty $\pm 10\%$.

⑤ Tolerance of expected light flux - 0 % / + 15 %. Measurement uncertainty $\pm 10\%$. Based on calculation.

⑥ Tolerance of power consumption P_{on} $\pm 10\%$. Measurement uncertainty $\pm 5\%$.

1. Standards

EC 62031
IEC 62778
IEC 62471
IEC 61000-4-2
IEC 60068-2-52
UL 8750 (for dry and damp locations)
GR-1217-CORE

1.1 Photometric code

Key for photometric code, e. g. 830 / 579

1 st digit		2 nd + 3 rd digit		4 th digit	5 th digit	6 th digit	
Code	CRI	Colour temperature in Kelvin x 100		MacAdam initial	MacAdam after 25% of the lifetime (max.6000h)	Luminous flux after 25% of the lifetime (max.6000h)	
7	70 – 79					Code	Luminous flux
8	80 – 89					7	≥ 70 %
9	≥90					8	≥ 80 %
						9	≥ 90 %

1.2 Energy classification

Type	Colour temperature	Forward current	Energy classification	Energy consumption
RLE 2x6 3000lm 730 HP EXC2 OTD Z19	3,000 K	700 mA	C	25 kWh / 1,000 h
RLE 2x6 3000lm 740 HP EXC2 OTD Z19	4,000 K	700 mA	C	25 kWh / 1,000 h
RLE 2x6 3000lm 750 HP EXC2 OTD Z19	5,000 K	700 mA	C	25 kWh / 1,000 h
RLE 2x6 3000lm 830 HP EXC2 OTD	3,000 K	700 mA	D	25 kWh / 1,000 h
RLE 2x6 3000lm 840 HP EXC2 OTD	4,000 K	700 mA	D	25 kWh / 1,000 h
RLE 2x6 3000lm 850 HP EXC2 OTD	5,000 K	700 mA	D	25 kWh / 1,000 h

Energy label and further information at www.tridonic.com in the certificates tab of the corresponding product page and at the EPREL data base <https://eprel.ec.europa.eu/>

2. Thermal details

2.1 tc point, ambient temperature and lifetime

The temperature at tp reference point is crucial for the light output and lifetime of a LED product.

For RLE a tp temperature of 75 °C has to be complied in order to achieve an optimum between heat sink requirements, light output and lifetime.

Compliance with the maximum permissible reference temperature at the tc point must be checked under operating conditions in a thermally stable state. The maximum value must be determined under worst-case conditions for the relevant application.

The tc and tp temperature of LED modules from Tridonic are measured at the same reference point.

2.2 Storage and humidity

Storage temperature	-40 ... +80 °C
---------------------	----------------

Operation only in non condensing environment.
Humidity during processing of the module should be between 0 to 70 %.

2.3 Thermal design and heat sink

The rated life of LED products depends to a large extent on the temperature. If the permissible temperature limits are exceeded, the life of the RLE will be greatly reduced or the RLE may be destroyed.

2.4 Heat sink values

RLE 2x6 3000lm EXC2 OTD

ta	tp	Forward current	R _{th, hs-a}	Cooling area
25 °C	75 °C	500 mA	10.32 K/W	65 cm ²
25 °C	75 °C	700 mA	7.56 K/W	88 cm ²
25 °C	75 °C	1,050 mA	4.19 K/W	159 cm ²
35 °C	75 °C	500 mA	8.25 K/W	81 cm ²
35 °C	75 °C	700 mA	6.04 K/W	110 cm ²
35 °C	75 °C	1,050 mA	3.35 K/W	199 cm ²
40 °C	75 °C	500 mA	7.22 K/W	92 cm ²
40 °C	75 °C	700 mA	5.29 K/W	126 cm ²
40 °C	75 °C	1,050 mA	2.93 K/W	228 cm ²
45 °C	75 °C	500 mA	6.19 K/W	108 cm ²
45 °C	75 °C	700 mA	4.53 K/W	147 cm ²
45 °C	75 °C	1,050 mA	2.51 K/W	266 cm ²
50 °C	75 °C	500 mA	5.15 K/W	129 cm ²
50 °C	75 °C	700 mA	3.78 K/W	177 cm ²
50 °C	75 °C	1,050 mA	2.09 K/W	319 cm ²
55 °C	75 °C	500 mA	4.12 K/W	162 cm ²
55 °C	75 °C	700 mA	3.02 K/W	221 cm ²
55 °C	75 °C	1,050 mA	1.67 K/W	399 cm ²
60 °C	75 °C	500 mA	3.09 K/W	216 cm ²
60 °C	75 °C	700 mA	2.26 K/W	295 cm ²
60 °C	75 °C	1,050 mA	1.25 K/W	533 cm ²

Notes

The actual cooling surface can differ because of the material, the structural shape, outside influences and the installation situation. Depending on the heat sink a heat conducting paste or heat conducting film might be necessary to keep the specified tp temperature.

3. Installation / wiring

3.1 Electrical supply/choice of LED driver

RLE modules from Tridonic are not protected against overvoltages, overcurrents, overloads or short-circuit currents. Safe and reliable operation can only be guaranteed in conjunction with a LED driver which complies with the relevant standards. The use of LED driver from Tridonic in combination with RLE modules guarantees the necessary protection for safe and reliable operation.

If a LED driver other than Tridonic is used, it must provide the following protection:

- Short-circuit protection
- Overload protection
- Overtemperature protection



RLE modules must be supplied by a constant current LED driver. Operation with a constant voltage LED driver will lead to an irreversible damage of the module.

If RLE modules are wired in parallel and a wire breaks or a complete module fails then the current passing through the other module increases. This may reduce its life considerably. In addition there can be slight differences in light output caused by tolerances.

RLE modules can be operated either from SELV LED drivers or from LED drivers with LV output voltage.



RLE modules are basic insulated up to 370 V if mounted with M3 screws or 670 V if mounted with M3 screws and lens (e.g. LEDiL Strada IP-2x6) against ground and can be mounted directly on earthed metal parts of the luminaire. If the max. output voltage of the LED driver (also against earth) is above 370 V / 670 V, an additional insulation between LED module and heat sink is required (for example by insulated thermal pads) or by a suitable luminaire construction. At voltages > 60 V an additional protection against direct touch (test finger) to the light emitting side of the module has to be guaranteed. This is typically achieved by means of a non removable light distributor over the module.

3.2 Integrated protection

The basic protection level consists of protection against reverse polarity.

3.3 Wiring

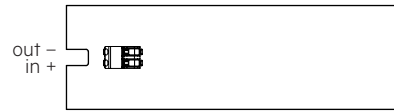

3.4 Wiring examples

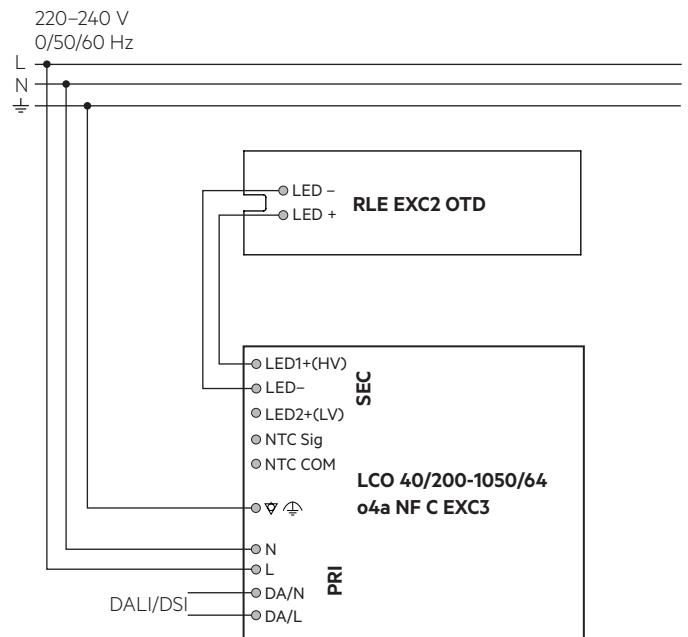

3.5 Wiring type and cross section

For wiring use stranded wire with ferrules or solid wire from 0.2 to 0.75 mm².
For the push-wire connection you have to strip the insulation (7–9 mm).

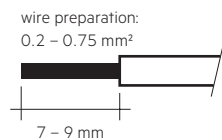

Inserting stranded wires / removing wires by lightly pressing on the push button.

3.6 Mounting instruction



None of the components of the RLE (substrate, LED, electronic components etc.) may be exposed to tensile or compressive stresses.

Max. torque for fixing: 0.5 Nm.

The LED modules are mounted onto a heat sink with M3 screws per module.



Chemical substance may harm the LED module. Chemical reactions could lead to colour shift, reduced luminous flux or a total failure of the module caused by corrosion of electrical connections.

Materials which are used in LED applications (e.g. sealings, adhesives) must not produce dissolver gas. They must not be condensation curing based, acetate curing based or contain sulfur, chlorine or phthalate.

Avoid corrosive atmosphere during usage and storage.

3.7 EOS/ESD safety guidelines



The device / module contains components that are sensitive to electrostatic discharge and may only be installed in the factory and on site if appropriate EOS/ESD protection measures have been taken. No special measures need be taken for devices/modules with enclosed casings (contact with the pc board not possible), just normal installation practice. Please note the requirements set out in the document EOS / ESD guidelines (Guideline_EOS_ESD.pdf) at: <http://www.tridonic.com/esd-protection>

4. Lifetime

4.1 Lifetime, lumen maintenance and failure rate

The light output of an LED module decreases over the lifetime, this is characterized with the L value.
L70 means that the LED module will give 70 % of its initial luminous flux. This value is always related to the number of operation hours and therefore defines the lifetime of an LED module.

As the L value is a statistical value and the lumen maintenance may vary over the delivered LED modules.

The B value defines the amount of modules which are below the specific L value, e.g. L70B10 means 10 % of the LED modules are below 70 % of the initial luminous flux, respectively 90 % will be above 70 % of the initial value. In addition the percentage of failed modules (fatal failure) is characterized by the C value.

The F value is the combination of the B and C value. That means for F degradation and complete failures are considered, e.g. L70F10 means 10 % of the LED modules may fail or be below 70 % of the initial luminous flux.

Operation below 200 mA may reduce lumen maintenance.

4.2 Lumen maintenance

Typ. forward current	tp temperature	L90 / B10	L90 / B50	L80 / B10	L80 / B50	L70 / B10	L70 / B50
500 mA	45 °C	>150,000 h	>150,000 h	>150,000 h	>150,000 h	>150,000 h	>150,000 h
	50 °C	>150,000 h	>150,000 h	>150,000 h	>150,000 h	>150,000 h	>150,000 h
	55 °C	>150,000 h	>150,000 h	>150,000 h	>150,000 h	>150,000 h	>150,000 h
	60 °C	>150,000 h	>150,000 h	>150,000 h	>150,000 h	>150,000 h	>150,000 h
	65 °C	>150,000 h	>150,000 h	>150,000 h	>150,000 h	>150,000 h	>150,000 h
	70 °C	>150,000 h	>150,000 h	>150,000 h	>150,000 h	>150,000 h	>150,000 h
	75 °C	>150,000 h	>150,000 h	>150,000 h	>150,000 h	>150,000 h	>150,000 h
	80 °C	>150,000 h	>150,000 h	>150,000 h	>150,000 h	>150,000 h	>150,000 h
	85 °C	>150,000 h	>150,000 h	>150,000 h	>150,000 h	>150,000 h	>150,000 h
	90 °C	>150,000 h	>150,000 h	>150,000 h	>150,000 h	>150,000 h	>150,000 h
700 mA	95 °C	136,000 h	>150,000 h	>150,000 h	>150,000 h	>150,000 h	>150,000 h
	100 °C	123,000 h	>150,000 h	>150,000 h	>150,000 h	>150,000 h	>150,000 h
	105 °C	110,000 h	>150,000 h	>150,000 h	>150,000 h	>150,000 h	>150,000 h
	45 °C	>150,000 h	>150,000 h	>150,000 h	>150,000 h	>150,000 h	>150,000 h
	50 °C	>150,000 h	>150,000 h	>150,000 h	>150,000 h	>150,000 h	>150,000 h
	55 °C	>150,000 h	>150,000 h	>150,000 h	>150,000 h	>150,000 h	>150,000 h
	60 °C	>150,000 h	>150,000 h	>150,000 h	>150,000 h	>150,000 h	>150,000 h
	65 °C	>150,000 h	>150,000 h	>150,000 h	>150,000 h	>150,000 h	>150,000 h
	70 °C	>150,000 h	>150,000 h	>150,000 h	>150,000 h	>150,000 h	>150,000 h
	75 °C	>150,000 h	>150,000 h	>150,000 h	>150,000 h	>150,000 h	>150,000 h
1,050 mA	80 °C	>150,000 h	>150,000 h	>150,000 h	>150,000 h	>150,000 h	>150,000 h
	85 °C	>150,000 h	>150,000 h	>150,000 h	>150,000 h	>150,000 h	>150,000 h
	90 °C	136,000 h	>150,000 h	>150,000 h	>150,000 h	>150,000 h	>150,000 h
	95 °C	123,000 h	>150,000 h	>150,000 h	>150,000 h	>150,000 h	>150,000 h
	100 °C	109,000 h	>150,000 h	>150,000 h	>150,000 h	>150,000 h	>150,000 h
	105 °C	96,000 h	>150,000 h	>150,000 h	>150,000 h	>150,000 h	>150,000 h
	45 °C	>150,000 h	>150,000 h	>150,000 h	>150,000 h	>150,000 h	>150,000 h
	50 °C	>150,000 h	>150,000 h	>150,000 h	>150,000 h	>150,000 h	>150,000 h
	55 °C	>150,000 h	>150,000 h	>150,000 h	>150,000 h	>150,000 h	>150,000 h
	60 °C	>150,000 h	>150,000 h	>150,000 h	>150,000 h	>150,000 h	>150,000 h
L00C03	65 °C	148,000 h	>150,000 h	>150,000 h	>150,000 h	>150,000 h	>150,000 h
	70 °C	145,000 h	>150,000 h	>150,000 h	>150,000 h	>150,000 h	>150,000 h
	75 °C	143,000 h	>150,000 h	>150,000 h	>150,000 h	>150,000 h	>150,000 h
	80 °C	140,000 h	>150,000 h	>150,000 h	>150,000 h	>150,000 h	>150,000 h
	85 °C	138,000 h	>150,000 h	>150,000 h	>150,000 h	>150,000 h	>150,000 h
	90 °C	136,000 h	>150,000 h	>150,000 h	>150,000 h	>150,000 h	>150,000 h
	95 °C	114,000 h	145,000 h	142,000 h	>150,000 h	>150,000 h	>150,000 h
	100 °C	93,000 h	140,000 h	133,000 h	>150,000 h	>150,000 h	>150,000 h
	105 °C	72,000 h	135,000 h	125,000 h	>150,000 h	>150,000 h	>150,000 h

L00C03 >150k h. At trated and Irated.

5. Electrical values

5.1 Typ. forward voltage vs. forward current

RLE 2x6 3000lm xxx HP EXC2 OTD

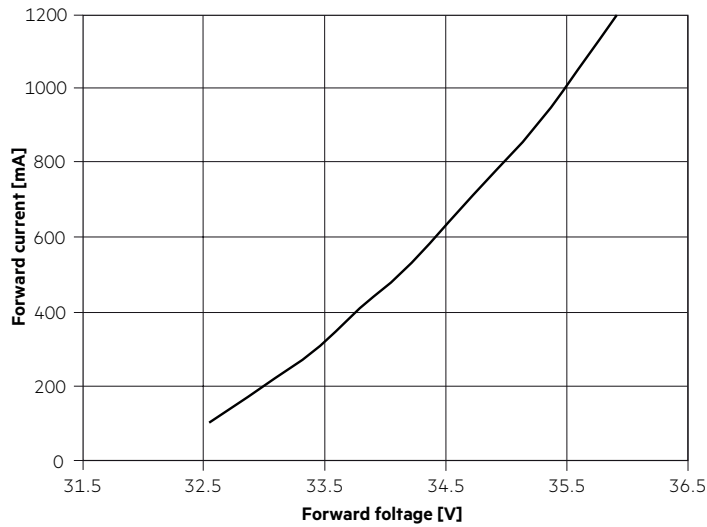

5.2 Forward voltage vs. tc temperature

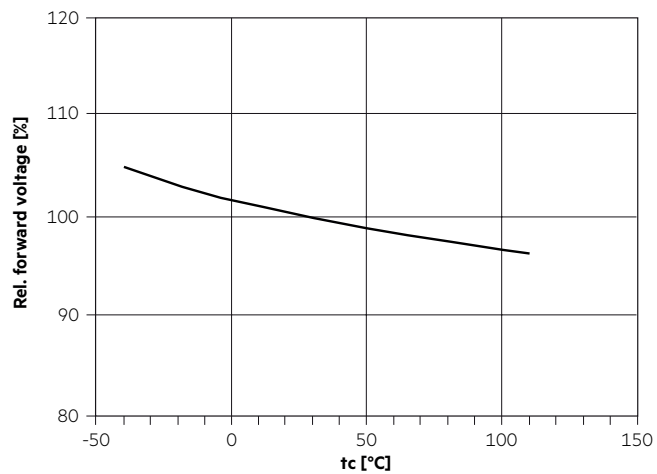

The diagrams are based on statistic values.

The real values can be different.

6. Photometric characteristics

6.1 Coordinates and tolerances according to CIE 1931

The specified colour coordinates are integral measured by current impulse of 700 mA and a duration of 100 ms.
 The ambient temperature of the measurement is $t_p = 75^\circ\text{C}$ steady state.
 The measurement tolerance of the colour coordinates are ± 0.01 .

3,000 K, CRI 80

	x0	y0
Centre	0.4339	0.4032

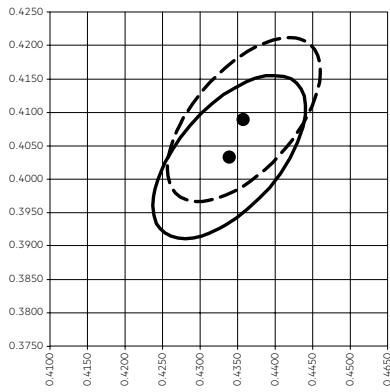

- MacAdam Ellipse: 5SDCM ($t_p = 75^\circ\text{C}$)
- - MacAdam Ellipse: 5SDCM ($t_a = 25^\circ\text{C}$)

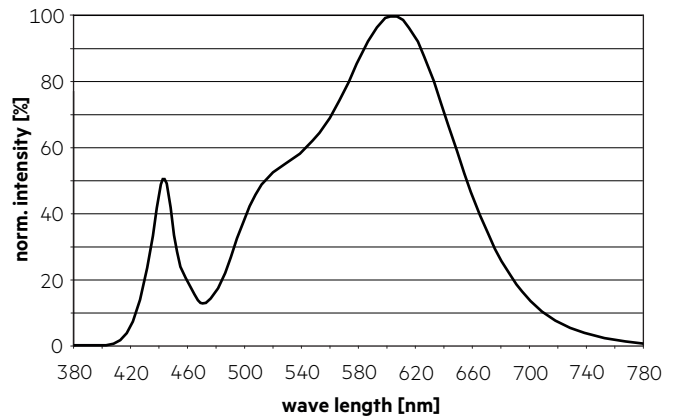

3,000 K, CRI 70

	x0	y0
Centre	0.4339	0.4032

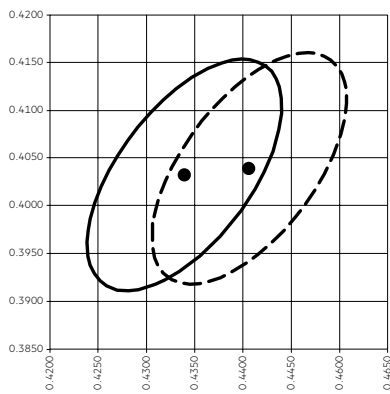

- MacAdam Ellipse: 5SDCM ($t_p = 75^\circ\text{C}$)
- - MacAdam Ellipse: 5SDCM ($t_a = 25^\circ\text{C}$)

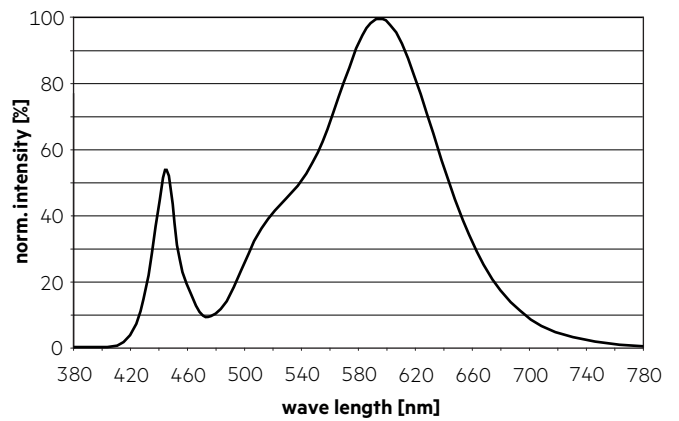

4,000 K, CRI 80

	x0	y0
Centre	0.3818	0.3796

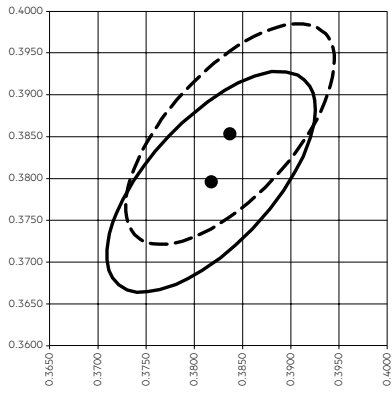

- MacAdam Ellipse: 5SDCM (tp = 75 °C)
- - MacAdam Ellipse: 5SDCM (ta = 25 °C)

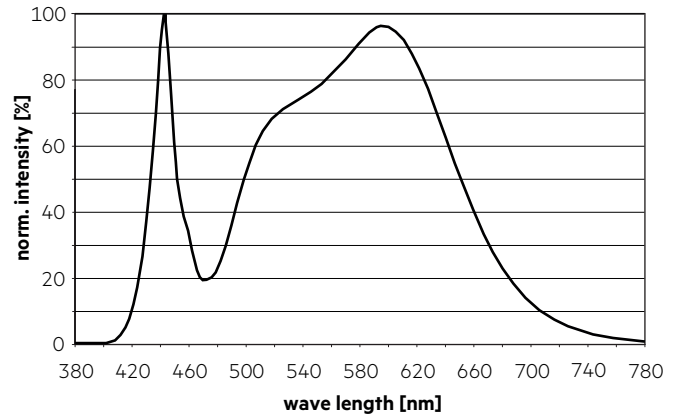

4,000 K, CRI 70

	x0	y0
Centre	0.3818	0.3796

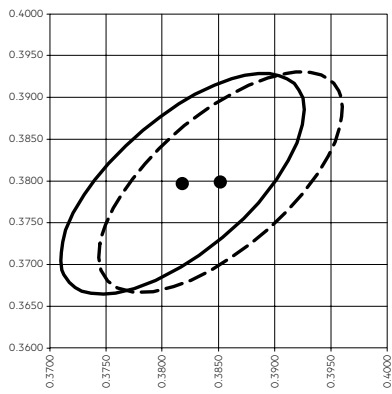

- MacAdam Ellipse: 5SDCM (tp = 75 °C)
- - MacAdam Ellipse: 5SDCM (ta = 25 °C)

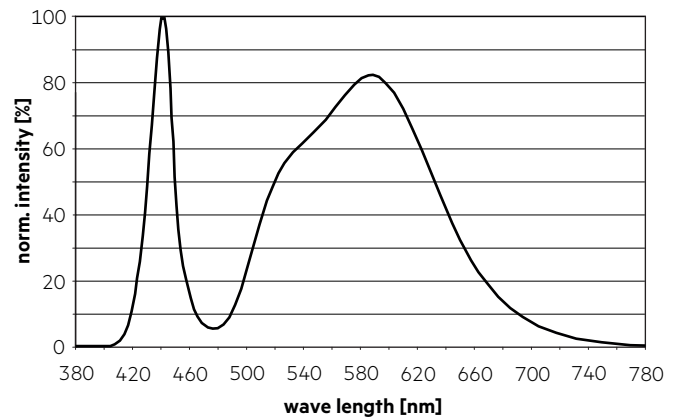

5,000 K, CRI 80

	x0	y0
Centre	0.3446	0.3551

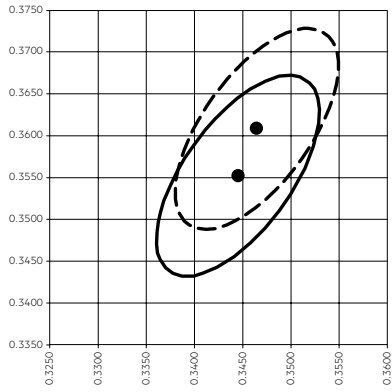

— MacAdam Ellipse: 5SDCM (tp = 75 °C)
 - - MacAdam Ellipse: 5SDCM (ta = 25 °C)

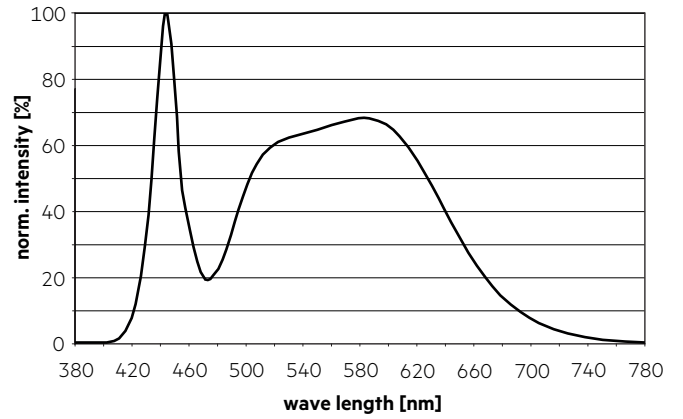

5,000 K, CRI 70

	x0	y0
Centre	0.3453	0.3553

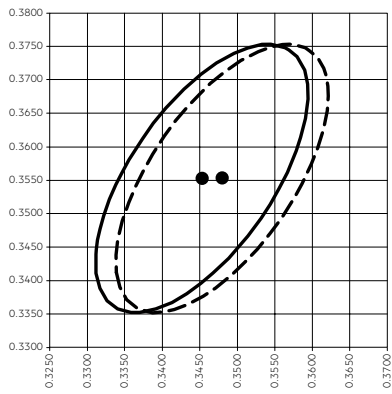

— MacAdam Ellipse: 5SDCM (tp = 75 °C)
 - - MacAdam Ellipse: 5SDCM (ta = 25 °C)

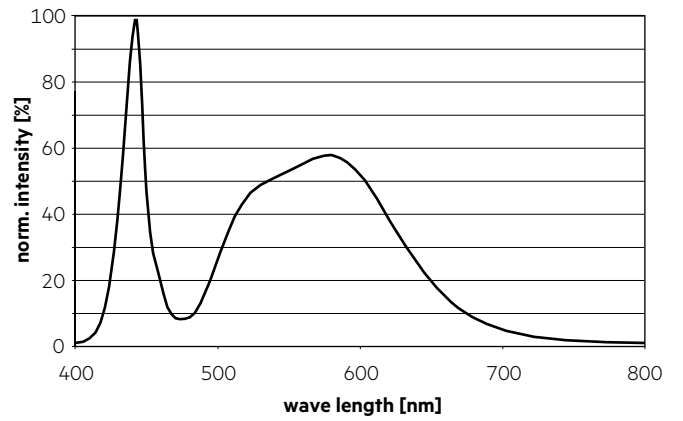

6.2 Light distribution

RLE G1 OTD modules are designed to be compatible with 50 x 50 mm lense arrays with 25.4 mm pitch distance. This allows multiple light distributions.

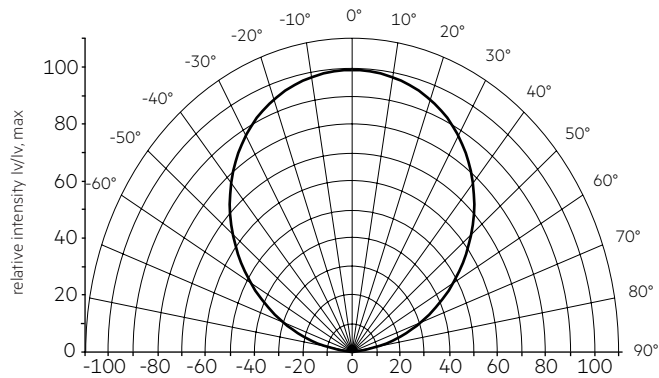

! The colour temperature is measured integral over the complete module. The single LED light points can have deviations in the colour coordinates within MacAdam 4.

6.3 Relative luminous flux vs. tc temperature

CRI 80

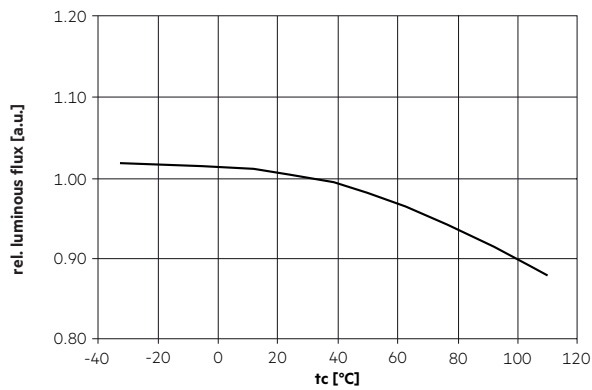

6.4 Relative luminous flux vs. operating current

CRI 80

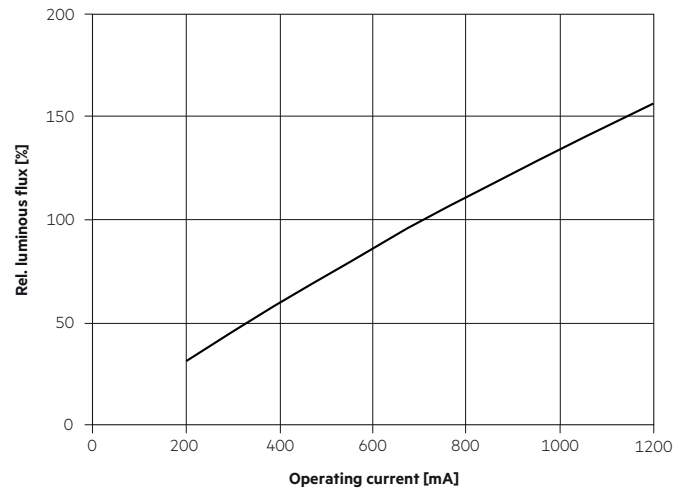

The diagrams are based on statistic values. The real values can be different.

7. Miscellaneous

7.1 Additional information

Additional technical information at www.tridonic.com → Technical Data

Guarantee conditions at www.tridonic.com → Services

Lifetime declarations are informative and represent no warranty claim.