

Module RLE 2x4 / 2x6 / 2x8 EXC3 OTD new variant

Modules RLE excite



RLE 2x4 3000lm HP EXC3 OTD



RLE 2x6 4500lm HP EXC3 OTD



RLE 2x8 6000lm HP EXC3 OTD

Product description

- _ High efficiency outdoor modules
- _ Suitable for harsh and humid outdoor conditions
- _ Tested acc. to salt spray test (IEC 60068-2-52) and harmful gas test (GR-1217-CORE)
- _ Huge performance temperature range from -40 ... +95 °C
- _ Surge capability (+/- to earth) 6 kV with Tridonic Outdoor LED driver
- _ Zhaga Book 15 certified
- _ For use with standard 2x2 lenses (e.g. LEDiL STRADA 2x2)
- _ Push-in terminals for simple and quick wiring
- _ HE ... High Efficiency, NM ... Nominal Mode, HO ... High Output
- _ Long lifetime up to 102,000 hours
- _ 8 years guarantee (conditions at <https://www.tridonic.com/en/int/services/manufacturer-guarantee-conditions>)

Optical properties

- _ Colour temperatures 2,200 K, 2,700 K, 3,000 K, 3,500 K, 4,000 K, 5,000 K and 6,500 K
- _ Efficacy of the LED module up to 207 lm/W
- _ Efficacy of the LED module 209 lm/W at Irated and tp = 25 °C
- _ Two colour rendering index to fit the application: CRI > 70 high efficiency, CRI > 80 for high colour rendering
- _ Small luminous flux tolerances

Mechanical properties

- _ Module dimension 49.5 x 121.4 mm, 49.5 x 172.2 mm and 49.5 x 223 mm
- _ Installation of the module together with lens in the luminaire by means of an M3 screw

Website

<http://www.tridonic.com/28006153>



Linear



High bay



Decorative



Downlights



Spotlights



Free-standing



Area



Floor | Wall



Street

Module RLE 2x4 / 2x6 / 2x8 EXC3 OTD new variant

Modules RLE excite

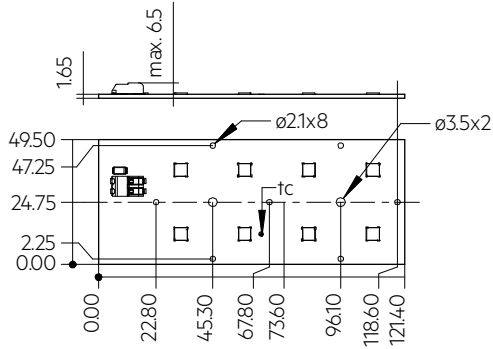

RLE 2x4 3000lm HP EXC3 OTD

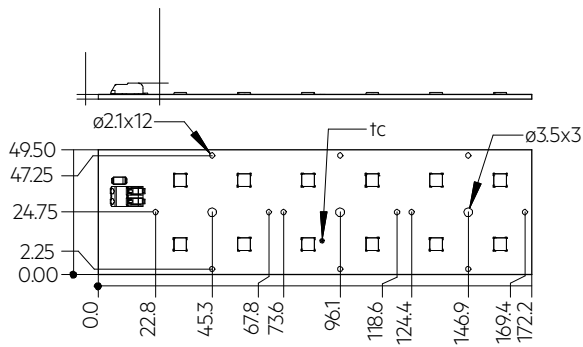

RLE 2x6 4500lm HP EXC3 OTD

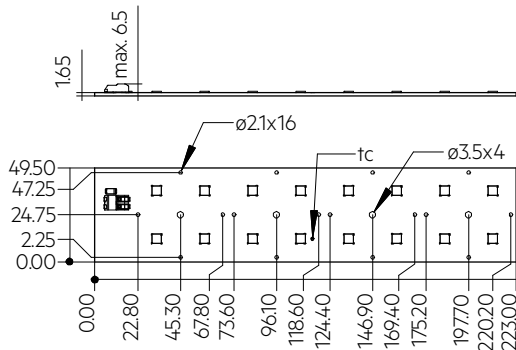

RLE 2x8 6000lm HP EXC3 OTD

Ordering data

Type	Article number	Colour temperature	Packaging, carton	Weight per pc.
RLE 2x4 3000lm 722 HP HE EXC3 OTD	28006153	2,200 K	80 pc(s).	0.027 kg
RLE 2x4 3000lm 727 HP HE EXC3 OTD	28006154	2,700 K	80 pc(s).	0.027 kg
RLE 2x4 3000lm 730 HP HE EXC3 OTD	28006155	3,000 K	80 pc(s).	0.027 kg
RLE 2x4 3000lm 735 HP HE EXC3 OTD	28006370	3,500 K	80 pc(s).	0.027 kg
RLE 2x4 3000lm 740 HP HE EXC3 OTD	28006156	4,000 K	80 pc(s).	0.027 kg
RLE 2x4 3000lm 750 HP HE EXC3 OTD	28006157	5,000 K	80 pc(s).	0.027 kg
RLE 2x4 3000lm 765 HP HE EXC3 OTD	28006163	6,500 K	80 pc(s).	0.027 kg
RLE 2x4 3000lm 822 HP HE EXC3 OTD	28006158	2,200 K	80 pc(s).	0.027 kg
RLE 2x4 3000lm 827 HP HE EXC3 OTD	28006159	2,700 K	80 pc(s).	0.027 kg
RLE 2x4 3000lm 830 HP HE EXC3 OTD	28006160	3,000 K	80 pc(s).	0.027 kg
RLE 2x4 3000lm 835 HP HE EXC3 OTD	28006371	3,500 K	80 pc(s).	0.027 kg
RLE 2x4 3000lm 840 HP HE EXC3 OTD	28006161	4,000 K	80 pc(s).	0.027 kg
RLE 2x4 3000lm 850 HP HE EXC3 OTD	28006707	5,000 K	80 pc(s).	0.027 kg
RLE 2x6 4500lm 722 HP HE EXC3 OTD	28006190	2,200 K	80 pc(s).	0.039 kg
RLE 2x6 4500lm 727 HP HE EXC3 OTD	28006191	2,700 K	80 pc(s).	0.039 kg
RLE 2x6 4500lm 730 HP HE EXC3 OTD	28006192	3,000 K	80 pc(s).	0.039 kg
RLE 2x6 4500lm 735 HP HE EXC3 OTD	28006380	3,500 K	80 pc(s).	0.039 kg
RLE 2x6 4500lm 740 HP HE EXC3 OTD	28006193	4,000 K	80 pc(s).	0.039 kg
RLE 2x6 4500lm 750 HP HE EXC3 OTD	28006194	5,000 K	80 pc(s).	0.039 kg
RLE 2x6 4500lm 835 HP HE EXC3 OTD	28006381	3,500 K	80 pc(s).	0.039 kg
RLE 2x6 4500lm 850 HP HE EXC3 OTD	28006709	5,000 K	80 pc(s).	0.039 kg
RLE 2x8 6000lm 722 HP HE EXC3 OTD	28006172	2,200 K	80 pc(s).	0.050 kg
RLE 2x8 6000lm 727 HP HE EXC3 OTD	28006173	2,700 K	80 pc(s).	0.050 kg
RLE 2x8 6000lm 730 HP HE EXC3 OTD	28006174	3,000 K	80 pc(s).	0.050 kg
RLE 2x8 6000lm 735 HP HE EXC3 OTD	28006375	3,500 K	80 pc(s).	0.050 kg
RLE 2x8 6000lm 740 HP HE EXC3 OTD	28006175	4,000 K	80 pc(s).	0.050 kg
RLE 2x8 6000lm 750 HP HE EXC3 OTD	28006250	5,000 K	80 pc(s).	0.050 kg
RLE 2x8 6000lm 765 HP HE EXC3 OTD	28006176	6,500 K	80 pc(s).	0.050 kg
RLE 2x8 6000lm 822 HP HE EXC3 OTD	28006177	2,200 K	80 pc(s).	0.050 kg
RLE 2x8 6000lm 827 HP HE EXC3 OTD	28006178	2,700 K	80 pc(s).	0.050 kg
RLE 2x8 6000lm 830 HP HE EXC3 OTD	28006179	3,000 K	80 pc(s).	0.050 kg
RLE 2x8 6000lm 835 HP HE EXC3 OTD	28006376	3,500 K	80 pc(s).	0.050 kg
RLE 2x8 6000lm 840 HP HE EXC3 OTD	28006180	4,000 K	80 pc(s).	0.050 kg
RLE 2x8 6000lm 850 HP HE EXC3 OTD	28006708	5,000 K	80 pc(s).	0.050 kg
RLE 2x4 3000lm 722 HP HE NTC EXC3 OTD	28006162	2,200 K	80 pc(s).	0.027 kg
RLE 2x4 3000lm 727 HP HE NTC EXC3 OTD	28006164	2,700 K	80 pc(s).	0.027 kg
RLE 2x4 3000lm 730 HP HE NTC EXC3 OTD	28006165	3,000 K	80 pc(s).	0.027 kg
RLE 2x4 3000lm 735 HP HE NTC EXC3 OTD	28006372	3,500 K	80 pc(s).	0.027 kg
RLE 2x4 3000lm 740 HP HE NTC EXC3 OTD	28006166	4,000 K	80 pc(s).	0.027 kg
RLE 2x4 3000lm 750 HP HE NTC EXC3 OTD	28006373	5,000 K	80 pc(s).	0.027 kg
RLE 2x4 3000lm 765 HP HE NTC EXC3 OTD	28006167	6,500 K	80 pc(s).	0.027 kg
RLE 2x4 3000lm 822 HP HE NTC EXC3 OTD	28006168	2,200 K	80 pc(s).	0.027 kg
RLE 2x4 3000lm 827 HP HE NTC EXC3 OTD	28006169	2,700 K	80 pc(s).	0.027 kg
RLE 2x4 3000lm 830 HP HE NTC EXC3 OTD	28006170	3,000 K	80 pc(s).	0.027 kg
RLE 2x4 3000lm 835 HP HE NTC EXC3 OTD	28006374	3,500 K	80 pc(s).	0.027 kg
RLE 2x4 3000lm 840 HP HE NTC EXC3 OTD	28006171	4,000 K	80 pc(s).	0.027 kg
RLE 2x4 3000lm 850 HP HE NTC EXC3 OTD	28006710	5,000 K	80 pc(s).	0.027 kg
RLE 2x6 4500lm 722 HP HE NTC EXC3 OTD	28006203	2,200 K	80 pc(s).	0.039 kg
RLE 2x6 4500lm 727 HP HE NTC EXC3 OTD	28006205	2,700 K	80 pc(s).	0.039 kg
RLE 2x6 4500lm 730 HP HE NTC EXC3 OTD	28006207	3,000 K	80 pc(s).	0.039 kg
RLE 2x6 4500lm 735 HP HE NTC EXC3 OTD	28006384	3,500 K	80 pc(s).	0.039 kg
RLE 2x6 4500lm 740 HP HE NTC EXC3 OTD	28006209	4,000 K	80 pc(s).	0.039 kg
RLE 2x6 4500lm 750 HP HE NTC EXC3 OTD	28006385	5,000 K	80 pc(s).	0.039 kg
RLE 2x6 4500lm 835 HP HE NTC EXC3 OTD	28006386	3,500 K	80 pc(s).	0.039 kg
RLE 2x6 4500lm 850 HP HE NTC EXC3 OTD	28006712	5,000 K	80 pc(s).	0.039 kg
RLE 2x8 6000lm 722 HP HE NTC EXC3 OTD	28006181	2,200 K	80 pc(s).	0.050 kg
RLE 2x8 6000lm 727 HP HE NTC EXC3 OTD	28006182	2,700 K	80 pc(s).	0.050 kg
RLE 2x8 6000lm 730 HP HE NTC EXC3 OTD	28006183	3,000 K	80 pc(s).	0.050 kg
RLE 2x8 6000lm 735 HP HE NTC EXC3 OTD	28006377	3,500 K	80 pc(s).	0.050 kg
RLE 2x8 6000lm 740 HP HE NTC EXC3 OTD	28006184	4,000 K	80 pc(s).	0.050 kg
RLE 2x8 6000lm 750 HP HE NTC EXC3 OTD	28006378	5,000 K	80 pc(s).	0.050 kg
RLE 2x8 6000lm 765 HP HE NTC EXC3 OTD	28006185	6,500 K	80 pc(s).	0.050 kg
RLE 2x8 6000lm 822 HP HE NTC EXC3 OTD	28006186	2,200 K	80 pc(s).	0.050 kg
RLE 2x8 6000lm 827 HP HE NTC EXC3 OTD	28006187	2,700 K	80 pc(s).	0.050 kg
RLE 2x8 6000lm 830 HP HE NTC EXC3 OTD	28006188	3,000 K	80 pc(s).	0.050 kg
RLE 2x8 6000lm 835 HP HE NTC EXC3 OTD	28006379	3,500 K	80 pc(s).	0.050 kg
RLE 2x8 6000lm 840 HP HE NTC EXC3 OTD	28006189	4,000 K	80 pc(s).	0.050 kg
RLE 2x8 6000lm 850 HP HE NTC EXC3 OTD	28006711	5,000 K	80 pc(s).	0.050 kg

Technical data

Beam characteristic	120°
Ambient temperature t_a	-40 ... +80 °C
t_p rated	75 °C
t_c	95 °C
I_{rated}	700 mA
I_{max}	1,800 mA
Max. permissible LF current ripple	2,000 mA
Max. permissible peak current	2,500 mA / max. 10 ms
Max. working voltage for insulation with lens ^①	670 V
Insulation test voltage	2.34 kV
Colour tolerance ^②	3 SDCM
ESD classification	Severity level 2
Risk group (IEC 62471)	RG2 (E _{thr} = 1055 lx, RG1 at d ≥ 80 cm)
Classification acc. to IEC 62031	Built-in
Type of protection	IP00
Lumen maintenance L70B50	102,000 h
Guarantee (conditions at www.tridonic.com)	8 Year(s)

Approval marks**Standards**

IEC 62031, IEC 62778, IEC 62471, IEC 61000-4-2, IEC 60068-2-52, UL 8750, GR-1217-CORE

Specific technical data

Type	Article number	Colour temperature	Photometric code	Useful luminous flux at tp = 25 °C	Expected luminous flux at tp rated	Type forward current	Min. forward voltage at tp rated	Max. forward voltage at tp = 25 °C	Power consumption Pon at tp = 25 °C	Efficacy of the module at tp = 25 °C	Expected efficacy of the module at tp rated	Colour rendering index CRI
Operating mode HE												
RLE 2x4 3000lm 722 HP HE EXC3 OTD	28006153	2,200 K	722/359	-	1,512 lm	400 mA	21.1 V	23.6 V	-	-	173 lm/W	>70
RLE 2x4 3000lm 727 HP HE EXC3 OTD	28006154	2,700 K	727/359	-	1,670 lm	400 mA	21.1 V	23.6 V	-	-	192 lm/W	>70
RLE 2x4 3000lm 730 HP HE EXC3 OTD	28006155	3,000 K	730/359	-	1,803 lm	400 mA	21.1 V	23.6 V	-	-	207 lm/W	>70
RLE 2x4 3000lm 735 HP HE EXC3 OTD	28006370	3,500 K	735/359	-	1,828 lm	400 mA	21.1 V	23.6 V	-	-	210 lm/W	>70
RLE 2x4 3000lm 740 HP HE EXC3 OTD	28006156	4,000 K	740/359	-	1,869 lm	400 mA	21.1 V	23.6 V	-	-	214 lm/W	>70
RLE 2x4 3000lm 750 HP HE EXC3 OTD	28006157	5,000 K	750/359	-	1,878 lm	400 mA	21.1 V	23.6 V	-	-	215 lm/W	>70
RLE 2x4 3000lm 765 HP HE EXC3 OTD	28006163	6,500 K	765/359	-	1,811 lm	400 mA	21.1 V	23.6 V	-	-	208 lm/W	>70
RLE 2x4 3000lm 822 HP HE EXC3 OTD	28006158	2,200 K	822/359	-	1,429 lm	400 mA	21.1 V	23.6 V	-	-	164 lm/W	>80
RLE 2x4 3000lm 827 HP HE EXC3 OTD	28006159	2,700 K	827/359	-	1,512 lm	400 mA	21.1 V	23.6 V	-	-	173 lm/W	>80
RLE 2x4 3000lm 830 HP HE EXC3 OTD	28006160	3,000 K	830/359	-	1,603 lm	400 mA	21.1 V	23.6 V	-	-	184 lm/W	>80
RLE 2x4 3000lm 835 HP HE EXC3 OTD	28006371	3,500 K	835/359	-	1,628 lm	400 mA	21.1 V	23.6 V	-	-	187 lm/W	>80
RLE 2x4 3000lm 840 HP HE EXC3 OTD	28006161	4,000 K	840/359	-	1,687 lm	400 mA	21.1 V	23.6 V	-	-	193 lm/W	>80
RLE 2x4 3000lm 850 HP HE EXC3 OTD	28006707	5,000 K	850/359	-	1,695 lm	400 mA	21.1 V	23.6 V	-	-	194 lm/W	>80
RLE 2x6 4500lm 722 HP HE EXC3 OTD	28006190	2,200 K	722/359	-	2,268 lm	400 mA	31.7 V	35.3 V	-	-	173 lm/W	>70
RLE 2x6 4500lm 727 HP HE EXC3 OTD	28006191	2,700 K	727/359	-	2,505 lm	400 mA	31.7 V	35.3 V	-	-	192 lm/W	>70
RLE 2x6 4500lm 730 HP HE EXC3 OTD	28006192	3,000 K	730/359	-	2,704 lm	400 mA	31.7 V	35.3 V	-	-	207 lm/W	>70
RLE 2x6 4500lm 735 HP HE EXC3 OTD	28006380	3,500 K	735/359	-	2,742 lm	400 mA	31.7 V	35.3 V	-	-	210 lm/W	>70
RLE 2x6 4500lm 740 HP HE EXC3 OTD	28006193	4,000 K	740/359	-	2,804 lm	400 mA	31.7 V	35.3 V	-	-	214 lm/W	>70
RLE 2x6 4500lm 750 HP HE EXC3 OTD	28006194	5,000 K	750/359	-	2,816 lm	400 mA	31.7 V	35.3 V	-	-	215 lm/W	>70
RLE 2x6 4500lm 835 HP HE EXC3 OTD	28006381	3,500 K	835/359	-	2,443 lm	400 mA	31.7 V	35.3 V	-	-	187 lm/W	>80
RLE 2x6 4500lm 850 HP HE EXC3 OTD	28006709	5,000 K	850/359	-	2,542 lm	400 mA	31.7 V	35.3 V	-	-	194 lm/W	>80
RLE 2x8 6000lm 722 HP HE EXC3 OTD	28006172	2,200 K	722/359	-	3,024 lm	400 mA	42.2 V	47.1 V	-	-	173 lm/W	>70
RLE 2x8 6000lm 727 HP HE EXC3 OTD	28006173	2,700 K	727/359	-	3,340 lm	400 mA	42.2 V	47.1 V	-	-	192 lm/W	>70
RLE 2x8 6000lm 730 HP HE EXC3 OTD	28006174	3,000 K	730/359	-	3,606 lm	400 mA	42.2 V	47.1 V	-	-	207 lm/W	>70
RLE 2x8 6000lm 735 HP HE EXC3 OTD	28006375	3,500 K	735/359	-	3,656 lm	400 mA	42.2 V	47.1 V	-	-	210 lm/W	>70
RLE 2x8 6000lm 740 HP HE EXC3 OTD	28006175	4,000 K	740/359	-	3,739 lm	400 mA	42.2 V	47.1 V	-	-	214 lm/W	>70
RLE 2x8 6000lm 750 HP HE EXC3 OTD	28006250	5,000 K	750/359	-	3,755 lm	400 mA	42.2 V	47.1 V	-	-	215 lm/W	>70
RLE 2x8 6000lm 765 HP HE EXC3 OTD	28006176	6,500 K	765/359	-	3,622 lm	400 mA	42.2 V	47.1 V	-	-	208 lm/W	>70
RLE 2x8 6000lm 822 HP HE EXC3 OTD	28006177	2,200 K	822/359	-	2,858 lm	400 mA	42.2 V	47.1 V	-	-	164 lm/W	>80
RLE 2x8 6000lm 827 HP HE EXC3 OTD	28006178	2,700 K	827/359	-	3,057 lm	400 mA	42.2 V	47.1 V	-	-	175 lm/W	>80
RLE 2x8 6000lm 830 HP HE EXC3 OTD	28006179	3,000 K	830/359	-	3,207 lm	400 mA	42.2 V	47.1 V	-	-	184 lm/W	>80
RLE 2x8 6000lm 835 HP HE EXC3 OTD	28006376	3,500 K	835/359	-	3,257 lm	400 mA	42.2 V	47.1 V	-	-	187 lm/W	>80
RLE 2x8 6000lm 840 HP HE EXC3 OTD	28006180	4,000 K	840/359	-	3,373 lm	400 mA	42.2 V	47.1 V	-	-	193 lm/W	>80
RLE 2x8 6000lm 850 HP HE EXC3 OTD	28006708	5,000 K	850/359	-	3,390 lm	400 mA	42.2 V	47.1 V	-	-	194 lm/W	>80
RLE 2x4 3000lm 722 HP HE NTC EXC3 OTD	28006162	2,200 K	722/359	-	1,512 lm	400 mA	21.1 V	23.6 V	-	-	173 lm/W	>70
RLE 2x4 3000lm 727 HP HE NTC EXC3 OTD	28006164	2,700 K	727/359	-	1,670 lm	400 mA	21.1 V	23.6 V	-	-	192 lm/W	>70
RLE 2x4 3000lm 730 HP HE NTC EXC3 OTD	28006165	3,000 K	730/359	-	1,803 lm	400 mA	21.1 V	23.6 V	-	-	207 lm/W	>70
RLE 2x4 3000lm 735 HP HE NTC EXC3 OTD	28006372	3,500 K	735/359	-	1,828 lm	400 mA	21.1 V	23.6 V	-	-	210 lm/W	>70
RLE 2x4 3000lm 740 HP HE NTC EXC3 OTD	28006166	4,000 K	740/359	-	1,869 lm	400 mA	21.1 V	23.6 V	-	-	214 lm/W	>70
RLE 2x4 3000lm 750 HP HE NTC EXC3 OTD	28006373	5,000 K	750/359	-	1,878 lm	400 mA	21.1 V	23.6 V	-	-	215 lm/W	>70
RLE 2x4 3000lm 765 HP HE NTC EXC3 OTD	28006167	6,500 K	765/359	-	1,811 lm	400 mA	21.1 V	23.6 V	-	-	208 lm/W	>70
RLE 2x4 3000lm 822 HP HE NTC EXC3 OTD	28006168	2,200 K	822/359	-	1,429 lm	400 mA	21.1 V	23.6 V	-	-	164 lm/W	>80
RLE 2x4 3000lm 827 HP HE NTC EXC3 OTD	28006169	2,700 K	827/359	-	1,512 lm	400 mA	21.1 V	23.6 V	-	-	173 lm/W	>80
RLE 2x4 3000lm 830 HP HE NTC EXC3 OTD	28006170	3,000 K	830/359	-	1,603 lm	400 mA	21.1 V	23.6 V	-	-	184 lm/W	>80
RLE 2x4 3000lm 835 HP HE NTC EXC3 OTD	28006374	3,500 K	835/359	-	1,628 lm	400 mA	21.1 V	23.6 V	-	-	187 lm/W	>80
RLE 2x4 3000lm 840 HP HE NTC EXC3 OTD	28006171	4,000 K	840/359	-	1,687 lm	400 mA	21.1 V	23.6 V	-	-	193 lm/W	>80
RLE 2x4 3000lm 850 HP HE NTC EXC3 OTD	28006710	5,000 K	850/359	-	1,695 lm	400 mA	21.1 V	23.6 V	-	-	194 lm/W	>80
RLE 2x6 4500lm 722 HP HE NTC EXC3 OTD	28006203	2,200 K	722/359	-	2,268 lm	400 mA	31.7 V	35.3 V	-	-	173 lm/W	>70
RLE 2x6 4500lm 727 HP HE NTC EXC3 OTD	28006205	2,700 K	727/359	-	2,505 lm	400 mA	31.7 V	35.3 V	-	-	192 lm/W	>70
RLE 2x6 4500lm 730 HP HE NTC EXC3 OTD	28006207	3,000 K	730/359	-	2,704 lm	400 mA	31.7 V	35.3 V	-	-	207 lm/W	>70
RLE 2x6 4500lm 735 HP HE NTC EXC3 OTD	28006384	3,500 K	735/359	-	2,742 lm	400 mA	31.7 V	35.3 V	-	-	210 lm/W	>70
RLE 2x6 4500lm 740 HP HE NTC EXC3 OTD	28006209	4,000 K	740/359	-	2,804 lm	400 mA	31.7 V	35.3 V	-	-	214 lm/W	>70
RLE 2x6 4500lm 750 HP HE NTC EXC3 OTD	28006385	5,000 K	750/359	-	2,816 lm	400 mA	31.7 V	35.3 V	-	-	215 lm/W	>70
RLE 2x6 4500lm 835 HP HE NTC EXC3 OTD	28006386	3,500 K	835/359	-	2,443 lm	400 mA	31.7 V	35.3 V	-	-	187 lm/W	>80
RLE 2x6 4500lm 850 HP HE NTC EXC3 OTD	28006712	5,000 K	850/359	-	2,542 lm	400 mA	31.7 V	35.3 V	-	-	194 lm/W	>80
RLE 2x8 6000lm 722 HP HE NTC EXC3 OTD	28006181	2,200 K	722/359	-	3,024 lm	400 mA	42.2 V	47.1 V	-	-	173 lm/W	>70
RLE 2x8 6000lm 727 HP HE NTC EXC3 OTD	28006182	2,700 K	727/359	-	3,340 lm	400 mA	42.2 V	47.1 V	-	-	192 lm/W	>70
RLE 2x8 6000lm 730 HP HE NTC EXC3 OTD	28006183	3,000 K	730/359	-	3,606 lm	400 mA	42.2 V	47.1 V	-	-	207 lm/W	>70
RLE 2x8 6000lm 735 HP HE NTC EXC3 OTD	28006377	3,500 K	735/359	-	3,656 lm	400 mA	42.2 V	47.1 V	-	-	210 lm/W	>70
RLE 2x8 6000lm 740 HP HE NTC EXC3 OTD	28006184	4,000 K	740/359	-	3,739 lm	400 mA	42.2 V	47.1 V	-	-	214 lm/W	>70
RLE 2x8 6000lm 750 HP HE NTC EXC3 OTD	28006378	5,000 K	750/359	-	3,755 lm	400 mA	42.2 V	47.1 V	-	-	215 lm/W	>70
RLE 2x8 6000lm 765 HP HE NTC EXC3 OTD	28006185	6,500 K	765/359	-	3,622 lm	400 mA	42.2 V	47.1 V	-	-	208 lm/W	>70
RLE 2x8 6000lm 822 HP HE NTC EXC3 OTD	28006186	2,200 K	822/359	-	2,858 lm	400 mA	42.2 V	47.1 V	-	-	164 lm/W	>80
RLE 2x8 6000lm 827 HP HE NTC EXC3 OTD	28006187	2,700 K	827/359	-	3,057 lm	400 mA	42.2 V	47.1 V	-	-	175 lm/W	>80
RLE 2x8 6000lm 830 HP HE NTC EXC3 OTD	28006188	3,000 K	830/359	-	3,207 lm	400 mA	42.2 V	47.1 V	-	-	184 lm/W	>80
RLE 2x8 6000lm 835 HP HE NTC EXC3 OTD	28006379	3,500 K	835/359	-	3,257 lm	400 mA	42.2 V	47.1 V	-	-	187 lm/W	>80

Type	Article number	Colour temperature	Photometric code	Useful luminous flux at tp = 25 °C	Expected luminous flux at tp rated	Typ. forward current	Min. forward voltage at tp rated	Max. forward voltage at tp = 25 °C	Power consumption	Efficacy of the module at tp = 25 °C	Expected efficacy of the module at tp rated	Colour rendering index CRI
RLE 2x8 6000lm 840 HP HE NTC EXC3 OTD	28006189	4,000 K	840/359	-	3,373 lm	400 mA	42.2 V	47.1 V	-	-	193 lm/W	>80
RLE 2x8 6000lm 850 HP HE NTC EXC3 OTD	28006711	5,000 K	850/359	-	3,390 lm	400 mA	42.2 V	47.1 V	-	-	194 lm/W	>80
Operating mode NM												
RLE 2x4 3000lm 722 HP HE EXC3 OTD	28006153	2,200 K	722/359	2,728 lm	2,578 lm	700 mA	21.9 V	24.4 V	16.1 W	169 lm/W	163 lm/W	>70
RLE 2x4 3000lm 727 HP HE EXC3 OTD	28006154	2,700 K	727/359	2,968 lm	2,848 lm	700 mA	21.9 V	24.4 V	16.1 W	184 lm/W	180 lm/W	>70
RLE 2x4 3000lm 730 HP HE EXC3 OTD	28006155	3,000 K	730/359	3,240 lm	3,074 lm	700 mA	21.9 V	24.4 V	16.1 W	201 lm/W	195 lm/W	>70
RLE 2x4 3000lm 735 HP HE EXC3 OTD	28006370	3,500 K	735/359	3,284 lm	3,117 lm	700 mA	21.9 V	24.4 V	16.1 W	204 lm/W	197 lm/W	>70
RLE 2x4 3000lm 740 HP HE EXC3 OTD	28006156	4,000 K	740/359	3,300 lm	3,188 lm	700 mA	21.9 V	24.4 V	16.1 W	205 lm/W	202 lm/W	>70
RLE 2x4 3000lm 750 HP HE EXC3 OTD	28006157	5,000 K	750/359	3,310 lm	3,202 lm	700 mA	21.9 V	24.4 V	16.1 W	206 lm/W	203 lm/W	>70
RLE 2x4 3000lm 765 HP HE EXC3 OTD	28006163	6,500 K	765/359	3,208 lm	3,089 lm	700 mA	21.9 V	24.4 V	16.1 W	199 lm/W	196 lm/W	>70
RLE 2x4 3000lm 822 HP HE EXC3 OTD	28006158	2,200 K	822/359	2,590 lm	2,437 lm	700 mA	21.9 V	24.4 V	16.1 W	161 lm/W	154 lm/W	>80
RLE 2x4 3000lm 827 HP HE EXC3 OTD	28006159	2,700 K	827/359	2,728 lm	2,578 lm	700 mA	21.9 V	24.4 V	16.1 W	169 lm/W	163 lm/W	>80
RLE 2x4 3000lm 830 HP HE EXC3 OTD	28006160	3,000 K	830/359	2,850 lm	2,734 lm	700 mA	21.9 V	24.4 V	16.1 W	177 lm/W	173 lm/W	>80
RLE 2x4 3000lm 835 HP HE EXC3 OTD	28006371	3,500 K	835/359	2,962 lm	2,777 lm	700 mA	21.9 V	24.4 V	16.1 W	184 lm/W	176 lm/W	>80
RLE 2x4 3000lm 840 HP HE EXC3 OTD	28006161	4,000 K	840/359	3,050 lm	2,876 lm	700 mA	21.9 V	24.4 V	16.1 W	189 lm/W	182 lm/W	>80
RLE 2x4 3000lm 850 HP HE EXC3 OTD	28006707	5,000 K	850/359	3,080 lm	2,890 lm	700 mA	21.9 V	24.4 V	16.1 W	191 lm/W	183 lm/W	>80
RLE 2x6 4500lm 722 HP HE EXC3 OTD	28006190	2,200 K	722/359	4,092 lm	3,868 lm	700 mA	32.8 V	36.5 V	24.1 W	170 lm/W	163 lm/W	>70
RLE 2x6 4500lm 727 HP HE EXC3 OTD	28006191	2,700 K	727/359	4,452 lm	4,271 lm	700 mA	32.8 V	36.5 V	24.1 W	185 lm/W	180 lm/W	>80
RLE 2x6 4500lm 730 HP HE EXC3 OTD	28006192	3,000 K	730/359	4,860 lm	4,612 lm	700 mA	32.8 V	36.5 V	24.1 W	202 lm/W	195 lm/W	>70
RLE 2x6 4500lm 735 HP HE EXC3 OTD	28006380	3,500 K	735/359	4,926 lm	4,675 lm	700 mA	32.8 V	36.5 V	24.1 W	204 lm/W	197 lm/W	>70
RLE 2x6 4500lm 740 HP HE EXC3 OTD	28006193	4,000 K	740/359	4,950 lm	4,782 lm	700 mA	32.8 V	36.5 V	24.1 W	205 lm/W	202 lm/W	>70
RLE 2x6 4500lm 750 HP HE EXC3 OTD	28006194	5,000 K	750/359	4,960 lm	4,803 lm	700 mA	32.8 V	36.5 V	24.1 W	206 lm/W	203 lm/W	>70
RLE 2x6 4500lm 835 HP HE EXC3 OTD	28006381	3,500 K	835/359	4,442 lm	4,165 lm	700 mA	32.8 V	36.5 V	24.1 W	184 lm/W	176 lm/W	>80
RLE 2x6 6000lm 850 HP HE EXC3 OTD	28006709	5,000 K	850/359	4,620 lm	4,335 lm	700 mA	32.8 V	36.5 V	24.1 W	192 lm/W	183 lm/W	>80
RLE 2x8 6000lm 722 HP HE EXC3 OTD	28006172	2,200 K	722/359	5,456 lm	5,157 lm	700 mA	43.7 V	48.7 V	32.2 W	169 lm/W	163 lm/W	>70
RLE 2x8 6000lm 727 HP HE EXC3 OTD	28006173	2,700 K	727/359	5,936 lm	5,695 lm	700 mA	43.7 V	48.7 V	32.2 W	184 lm/W	180 lm/W	>70
RLE 2x8 6000lm 730 HP HE EXC3 OTD	28006174	3,000 K	730/359	6,480 lm	6,149 lm	700 mA	43.7 V	48.7 V	32.2 W	201 lm/W	195 lm/W	>70
RLE 2x8 6000lm 735 HP HE EXC3 OTD	28006375	3,500 K	735/359	6,568 lm	6,234 lm	700 mA	43.7 V	48.7 V	32.2 W	204 lm/W	197 lm/W	>70
RLE 2x8 6000lm 740 HP HE EXC3 OTD	28006175	4,000 K	740/359	6,600 lm	6,375 lm	700 mA	43.7 V	48.7 V	32.2 W	205 lm/W	202 lm/W	>70
RLE 2x8 6000lm 750 HP HE EXC3 OTD	28006250	5,000 K	750/359	6,620 lm	6,404 lm	700 mA	43.7 V	48.7 V	32.2 W	206 lm/W	203 lm/W	>70
RLE 2x8 6000lm 765 HP HE EXC3 OTD	28006176	6,500 K	765/359	6,416 lm	6,177 lm	700 mA	43.7 V	48.7 V	32.2 W	199 lm/W	195 lm/W	>70
RLE 2x8 6000lm 822 HP HE EXC3 OTD	28006177	2,200 K	822/359	5,180 lm	4,874 lm	700 mA	43.7 V	48.7 V	32.2 W	161 lm/W	154 lm/W	>80
RLE 2x8 6000lm 827 HP HE EXC3 OTD	28006178	2,700 K	827/359	5,456 lm	5,214 lm	700 mA	43.7 V	48.7 V	32.2 W	169 lm/W	165 lm/W	>80
RLE 2x8 6000lm 830 HP HE EXC3 OTD	28006179	3,000 K	830/359	5,700 lm	5,469 lm	700 mA	43.7 V	48.7 V	32.2 W	177 lm/W	173 lm/W	>80
RLE 2x8 6000lm 835 HP HE EXC3 OTD	28006376	3,500 K	835/359	5,924 lm	5,554 lm	700 mA	43.7 V	48.7 V	32.2 W	184 lm/W	176 lm/W	>80
RLE 2x8 6000lm 840 HP HE EXC3 OTD	28006180	4,000 K	840/359	6,100 lm	5,752 lm	700 mA	43.7 V	48.7 V	32.2 W	189 lm/W	182 lm/W	>80
RLE 2x8 6000lm 850 HP HE EXC3 OTD	28006708	5,000 K	850/359	6,160 lm	5,780 lm	700 mA	43.7 V	48.7 V	32.2 W	191 lm/W	183 lm/W	>80
RLE 2x4 3000lm 722 HP HE NTC EXC3 OTD	28006162	2,200 K	722/359	2,728 lm	2,578 lm	700 mA	21.9 V	24.4 V	16.1 W	169 lm/W	163 lm/W	>70
RLE 2x4 3000lm 727 HP HE NTC EXC3 OTD	28006164	2,700 K	727/359	2,968 lm	2,848 lm	700 mA	21.9 V	24.4 V	16.1 W	184 lm/W	180 lm/W	>70
RLE 2x4 3000lm 730 HP HE NTC EXC3 OTD	28006165	3,000 K	730/359	3,240 lm	3,074 lm	700 mA	21.9 V	24.4 V	16.1 W	201 lm/W	195 lm/W	>70
RLE 2x4 3000lm 735 HP HE NTC EXC3 OTD	28006372	3,500 K	735/359	3,284 lm	3,117 lm	700 mA	21.9 V	24.4 V	16.1 W	204 lm/W	197 lm/W	>70
RLE 2x4 3000lm 740 HP HE NTC EXC3 OTD	28006166	4,000 K	740/359	3,300 lm	3,188 lm	700 mA	21.9 V	24.4 V	16.1 W	205 lm/W	202 lm/W	>70
RLE 2x4 3000lm 750 HP HE NTC EXC3 OTD	28006373	5,000 K	750/359	3,310 lm	3,202 lm	700 mA	21.9 V	24.4 V	16.1 W	206 lm/W	203 lm/W	>70
RLE 2x4 3000lm 765 HP HE NTC EXC3 OTD	28006167	6,500 K	765/359	3,208 lm	3,089 lm	700 mA	21.9 V	24.4 V	16.1 W	199 lm/W	196 lm/W	>70
RLE 2x4 3000lm 822 HP HE NTC EXC3 OTD	28006168	2,200 K	822/359	2,590 lm	2,437 lm	700 mA	21.9 V	24.4 V	16.1 W	161 lm/W	154 lm/W	>80
RLE 2x4 3000lm 827 HP HE NTC EXC3 OTD	28006169	2,700 K	827/359	2,728 lm	2,578 lm	700 mA	21.9 V	24.4 V	16.1 W	169 lm/W	163 lm/W	>80
RLE 2x4 3000lm 830 HP HE NTC EXC3 OTD	28006170	3,000 K	830/359	2,850 lm	2,734 lm	700 mA	21.9 V	24.4 V	16.1 W	177 lm/W	173 lm/W	>80
RLE 2x4 3000lm 835 HP HE NTC EXC3 OTD	28006374	3,500 K	835/359	2,962 lm	2,777 lm	700 mA	21.9 V	24.4 V	16.1 W	184 lm/W	176 lm/W	>80
RLE 2x4 3000lm 840 HP HE NTC EXC3 OTD	28006171	4,000 K	840/359	3,050 lm	2,876 lm	700 mA	21.9 V	24.4 V	16.1 W	189 lm/W	182 lm/W	>80
RLE 2x4 3000lm 850 HP HE NTC EXC3 OTD	28006710	5,000 K	850/359	3,080 lm	2,890 lm	700 mA	21.9 V	24.4 V	16.1 W	191 lm/W	183 lm/W	>80
RLE 2x6 4500lm 722 HP HE NTC EXC3 OTD	28006203	2,200 K	722/359	4,092 lm	3,868 lm	700 mA	32.8 V	36.5 V	24.1 W	170 lm/W	163 lm/W	>70
RLE 2x6 4500lm 727 HP HE NTC EXC3 OTD	28006205	2,700 K	727/359	4,452 lm	4,271 lm	700 mA	32.8 V	36.5 V	24.1 W	185 lm/W	180 lm/W	>70
RLE 2x6 4500lm 730 HP HE NTC EXC3 OTD	28006207	3,000 K	730/359	4,860 lm	4,612 lm	700 mA	32.8 V	36.5 V	24.1 W	202 lm/W	195 lm/W	>70
RLE 2x6 4500lm 735 HP HE NTC EXC3 OTD	28006384	3,500 K	735/359	4,926 lm	4,675 lm	700 mA	32.8 V	36.5 V	24.1 W	204 lm/W	197 lm/W	>70
RLE 2x6 4500lm 740 HP HE NTC EXC3 OTD	28006209	4,000 K	740/359	4,950 lm	4,782 lm	700 mA	32.8 V	36.5 V	24.1 W	205 lm/W	202 lm/W	>70
RLE 2x6 4500lm 750 HP HE NTC EXC3 OTD	28006385	5,000 K	750/359	4,960 lm	4,803 lm	700 mA	32.8 V	36.5 V	24.1 W	206 lm/W	203 lm/W	>70
RLE 2x6 4500lm 835 HP HE NTC EXC3 OTD	28006386	3,500 K	835/359	4,442 lm	4,165 lm	700 mA	32.8 V	36.5 V	24.1 W	184 lm/W	176 lm/W	>80
RLE 2x6 4500lm 850 HP HE NTC EXC3 OTD	28006712	5,000 K	850/359	4,620 lm	4,335 lm	700 mA	32.8 V	36.5 V	24.1 W	192 lm/W	183 lm/W	>80
RLE 2x8 6000lm 722 HP HE NTC EXC3 OTD	28006181	2,200 K	722/359	5,456 lm	5,157 lm	700 mA	43.7 V	48.7 V	32.2 W	169 lm/W	163 lm/W	>70
RLE 2x8 6000lm 727 HP HE NTC EXC3 OTD	28006182	2,700 K	727/359	5,936 lm	5,695 lm	700 mA	43.7 V	48.7 V	32.2 W	184 lm/W	180 lm/W	>70
RLE 2x8 6000lm 730 HP HE NTC EXC3 OTD	28006183	3,000 K	730/359	6,480 lm	6,149 lm	700 mA	43.7 V	48.7 V	32.2 W	201 lm/W	195 lm/W	>70
RLE 2x8 6000lm 735 HP HE NTC EXC3 OTD	28006377	3,500 K	735/359	6,568 lm	6,234 lm	700 mA	43.7 V	48.7 V	32.2 W	204 lm/W	197 lm/W	>70
RLE 2x8 6000lm 740 HP HE NTC EXC3 OTD	28006184	4,000 K	740/359	6,600 lm	6,375 lm	700 mA	43.7 V	48.7 V	32.2 W	205 lm/W	202 lm/W	>70
RLE 2x8 6000lm 750 HP HE NTC EXC3 OTD	28006378	5,000 K	750/359	6,620 lm	6,404 lm	700 mA	43.7 V	48.7 V	32.2 W	206 lm/W	203 lm/W	>70
RLE 2x8 6000lm 765 HP HE NTC EXC3 OTD	28006185	6,500 K	765/359	6,416 lm	6,177 lm	700 mA	43.7 V	48.7 V	32.2 W	199 lm/W	195 lm/W	>70
RLE 2x8 6000lm 822 HP HE NTC EXC3 OTD	28006186	2,200 K	822/359	5,180 lm	4,874 lm	700 mA	43.7 V	48.7 V	32.2 W	161 lm/W	154 lm/W	>80
RLE 2x8 6000lm 827 HP HE NTC EXC3 OTD	28006187	2,700 K	827/359	2,728 lm	2,578 lm	700 mA	43.7 V	48.7 V	32.2 W	169 lm/W	165 lm/W	>80
RLE 2x8 6000lm 830 HP HE NTC EXC3 OTD	28006188	3,000 K	830/359	5,700 lm	5,469 lm	700 mA	43.7 V	48.7 V	32.2 W	177 lm/W	173 lm/W	>80

Type	Article number	Colour temperature	Photometric code	Useful luminous flux at tp = 25 °C	Expected luminous flux at tp rated	Typ. forward current	Min. forward voltage at tp rated	Max. forward voltage at tp = 25 °C	Power consumption Pon at tp = 25 °C	Efficacy of the module at tp = 25 °C	Expected efficacy of the module at tp rated	Colour rendering index CRI
RLE 2x8 6000lm 835 HP HE NTC EXC3 OTD	28006379	3,500 K	835/359	5,924 lm	554 lm	700 mA	43.7 V	48.7 V	32.2 W	184 lm/W	176 lm/W	>80
RLE 2x8 6000lm 840 HP HE NTC EXC3 OTD	28006189	4,000 K	840/359	6,100 lm	5,752 lm	700 mA	43.7 V	48.7 V	32.2 W	189 lm/W	182 lm/W	>80
RLE 2x8 6000lm 850 HP HE NTC EXC3 OTD	28006711	5,000 K	850/359	6,160 lm	5,780 lm	700 mA	43.7 V	48.7 V	32.2 W	191 lm/W	183 lm/W	>80
Operating mode HO												
RLE 2x4 3000lm 722 HP HE EXC3 OTD	28006153	2,200 K	722/359	-	5,192 lm	1,500 mA	23.8 V	26.3 V	-	-	141 lm/W	>70
RLE 2x4 3000lm 727 HP HE EXC3 OTD	28006154	2,700 K	727/359	-	5,734 lm	1,500 mA	23.8 V	26.3 V	-	-	156 lm/W	>70
RLE 2x4 3000lm 730 HP HE EXC3 OTD	28006155	3,000 K	730/359	-	6,190 lm	1,500 mA	23.8 V	26.3 V	-	-	169 lm/W	>70
RLE 2x4 3000lm 735 HP HE EXC3 OTD	28006370	3,500 K	735/359	-	6,276 lm	1,500 mA	23.8 V	26.3 V	-	-	171 lm/W	>70
RLE 2x4 3000lm 740 HP HE EXC3 OTD	28006156	4,000 K	740/359	-	6,419 lm	1,500 mA	23.8 V	26.3 V	-	-	175 lm/W	>70
RLE 2x4 3000lm 750 HP HE EXC3 OTD	28006157	5,000 K	750/359	-	6,447 lm	1,500 mA	23.8 V	26.3 V	-	-	176 lm/W	>70
RLE 2x4 3000lm 765 HP HE EXC3 OTD	28006163	6,500 K	765/359	-	6,219 lm	1,500 mA	23.8 V	26.3 V	-	-	169 lm/W	>70
RLE 2x4 3000lm 822 HP HE EXC3 OTD	28006158	2,200 K	822/359	-	4,907 lm	1,500 mA	23.8 V	26.3 V	-	-	134 lm/W	>80
RLE 2x4 3000lm 827 HP HE EXC3 OTD	28006159	2,700 K	827/359	-	5,192 lm	1,500 mA	23.8 V	26.3 V	-	-	141 lm/W	>80
RLE 2x4 3000lm 830 HP HE EXC3 OTD	28006160	3,000 K	830/359	-	5,506 lm	1,500 mA	23.8 V	26.3 V	-	-	150 lm/W	>80
RLE 2x4 3000lm 835 HP HE EXC3 OTD	28006371	3,500 K	835/359	-	5,591 lm	1,500 mA	23.8 V	26.3 V	-	-	152 lm/W	>80
RLE 2x4 3000lm 840 HP HE EXC3 OTD	28006161	4,000 K	840/359	-	5,791 lm	1,500 mA	23.8 V	26.3 V	-	-	158 lm/W	>80
RLE 2x4 3000lm 850 HP HE EXC3 OTD	28006707	5,000 K	850/359	-	5,820 lm	1,500 mA	23.8 V	26.3 V	-	-	159 lm/W	>80
RLE 2x6 4500lm 722 HP HE EXC3 OTD	28006190	2,200 K	722/359	-	7,788 lm	1,500 mA	35.6 V	39.5 V	-	-	141 lm/W	>70
RLE 2x6 4500lm 727 HP HE EXC3 OTD	28006191	2,700 K	727/359	-	8,601 lm	1,500 mA	35.6 V	39.5 V	-	-	156 lm/W	>70
RLE 2x6 4500lm 730 HP HE EXC3 OTD	28006192	3,000 K	730/359	-	9,286 lm	1,500 mA	35.6 V	39.5 V	-	-	169 lm/W	>70
RLE 2x6 4500lm 735 HP HE EXC3 OTD	28006380	3,500 K	735/359	-	9,414 lm	1,500 mA	35.6 V	39.5 V	-	-	171 lm/W	>70
RLE 2x6 4500lm 740 HP HE EXC3 OTD	28006193	4,000 K	740/359	-	9,628 lm	1,500 mA	35.6 V	39.5 V	-	-	175 lm/W	>70
RLE 2x6 4500lm 750 HP HE EXC3 OTD	28006194	5,000 K	750/359	-	9,671 lm	1,500 mA	35.6 V	39.5 V	-	-	176 lm/W	>70
RLE 2x6 6000lm 835 HP HE EXC3 OTD	28006381	3,500 K	835/359	-	8,387 lm	1,500 mA	35.6 V	39.5 V	-	-	152 lm/W	>80
RLE 2x6 4500lm 850 HP HE EXC3 OTD	28006709	5,000 K	850/359	-	8,729 lm	1,500 mA	35.6 V	39.5 V	-	-	159 lm/W	>80
RLE 2x8 6000lm 722 HP HE EXC3 OTD	28006172	2,200 K	722/359	-	10,384 lm	1,500 mA	47.5 V	52.6 V	-	-	141 lm/W	>70
RLE 2x8 6000lm 727 HP HE EXC3 OTD	28006173	2,700 K	727/359	-	11,468 lm	1,500 mA	47.5 V	52.6 V	-	-	156 lm/W	>70
RLE 2x8 6000lm 730 HP HE EXC3 OTD	28006174	3,000 K	730/359	-	12,381 lm	1,500 mA	47.5 V	52.6 V	-	-	169 lm/W	>70
RLE 2x8 6000lm 735 HP HE EXC3 OTD	28006375	3,500 K	735/359	-	12,552 lm	1,500 mA	47.5 V	52.6 V	-	-	171 lm/W	>70
RLE 2x8 6000lm 740 HP HE EXC3 OTD	28006175	4,000 K	740/359	-	12,873 lm	1,500 mA	47.5 V	52.6 V	-	-	175 lm/W	>70
RLE 2x8 6000lm 750 HP HE EXC3 OTD	28006250	5,000 K	750/359	-	12,894 lm	1,500 mA	47.5 V	52.6 V	-	-	176 lm/W	>70
RLE 2x8 6000lm 765 HP HE EXC3 OTD	28006176	6,500 K	765/359	-	12,438 lm	1,500 mA	47.5 V	52.6 V	-	-	169 lm/W	>70
RLE 2x8 6000lm 822 HP HE EXC3 OTD	28006177	2,200 K	822/359	-	9,813 lm	1,500 mA	47.5 V	52.6 V	-	-	134 lm/W	>80
RLE 2x8 6000lm 827 HP HE EXC3 OTD	28006178	2,700 K	827/359	-	10,498 lm	1,500 mA	47.5 V	52.6 V	-	-	143 lm/W	>80
RLE 2x8 6000lm 830 HP HE EXC3 OTD	28006179	3,000 K	830/359	-	11,012 lm	1,500 mA	47.5 V	52.6 V	-	-	150 lm/W	>80
RLE 2x8 6000lm 835 HP HE EXC3 OTD	28006376	3,500 K	835/359	-	11,183 lm	1,500 mA	47.5 V	52.6 V	-	-	152 lm/W	>80
RLE 2x8 6000lm 840 HP HE EXC3 OTD	28006180	4,000 K	840/359	-	11,582 lm	1,500 mA	47.5 V	52.6 V	-	-	158 lm/W	>80
RLE 2x8 6000lm 850 HP HE EXC3 OTD	28006708	5,000 K	850/359	-	11,639 lm	1,500 mA	47.5 V	52.6 V	-	-	159 lm/W	>80
RLE 2x4 3000lm 722 HP HE NTC EXC3 OTD	28006162	2,200 K	722/359	-	5,192 lm	1,500 mA	23.8 V	26.3 V	-	-	141 lm/W	>70
RLE 2x4 3000lm 727 HP HE NTC EXC3 OTD	28006164	2,700 K	727/359	-	5,734 lm	1,500 mA	23.8 V	26.3 V	-	-	156 lm/W	>70
RLE 2x4 3000lm 730 HP HE NTC EXC3 OTD	28006165	3,000 K	730/359	-	6,190 lm	1,500 mA	23.8 V	26.3 V	-	-	169 lm/W	>70
RLE 2x4 3000lm 735 HP HE NTC EXC3 OTD	28006372	3,500 K	735/359	-	6,276 lm	1,500 mA	23.8 V	26.3 V	-	-	171 lm/W	>70
RLE 2x4 3000lm 740 HP HE NTC EXC3 OTD	28006166	4,000 K	740/359	-	6,419 lm	1,500 mA	23.8 V	26.3 V	-	-	175 lm/W	>70
RLE 2x4 3000lm 750 HP HE NTC EXC3 OTD	28006373	5,000 K	750/359	-	6,447 lm	1,500 mA	23.8 V	26.3 V	-	-	176 lm/W	>70
RLE 2x4 3000lm 765 HP HE NTC EXC3 OTD	28006167	6,500 K	765/359	-	6,219 lm	1,500 mA	23.8 V	26.3 V	-	-	169 lm/W	>70
RLE 2x4 3000lm 822 HP HE NTC EXC3 OTD	28006168	2,200 K	822/359	-	4,907 lm	1,500 mA	23.8 V	26.3 V	-	-	134 lm/W	>80
RLE 2x4 3000lm 827 HP HE NTC EXC3 OTD	28006169	2,700 K	827/359	-	10,498 lm	1,500 mA	47.5 V	52.6 V	-	-	141 lm/W	>80
RLE 2x4 3000lm 830 HP HE NTC EXC3 OTD	28006170	3,000 K	830/359	-	5,506 lm	1,500 mA	23.8 V	26.3 V	-	-	150 lm/W	>80
RLE 2x4 3000lm 835 HP HE NTC EXC3 OTD	28006374	3,500 K	835/359	-	5,591 lm	1,500 mA	23.8 V	26.3 V	-	-	152 lm/W	>80
RLE 2x4 3000lm 840 HP HE NTC EXC3 OTD	28006171	4,000 K	840/359	-	5,791 lm	1,500 mA	23.8 V	26.3 V	-	-	158 lm/W	>80
RLE 2x4 3000lm 850 HP HE NTC EXC3 OTD	28006710	5,000 K	850/359	-	5,820 lm	1,500 mA	23.8 V	26.3 V	-	-	159 lm/W	>80
RLE 2x6 4500lm 722 HP HE NTC EXC3 OTD	28006203	2,200 K	722/359	-	7,788 lm	1,500 mA	35.6 V	39.5 V	-	-	141 lm/W	>70
RLE 2x6 4500lm 727 HP HE NTC EXC3 OTD	28006205	2,700 K	727/359	-	8,601 lm	1,500 mA	35.6 V	39.5 V	-	-	156 lm/W	>70
RLE 2x6 4500lm 730 HP HE NTC EXC3 OTD	28006207	3,000 K	730/359	-	9,286 lm	1,500 mA	35.6 V	39.5 V	-	-	169 lm/W	>70
RLE 2x6 4500lm 735 HP HE NTC EXC3 OTD	28006384	3,500 K	735/359	-	9,414 lm	1,500 mA	35.6 V	39.5 V	-	-	171 lm/W	>70
RLE 2x6 4500lm 740 HP HE NTC EXC3 OTD	28006209	4,000 K	740/359	-	9,628 lm	1,500 mA	35.6 V	39.5 V	-	-	175 lm/W	>70
RLE 2x6 4500lm 750 HP HE NTC EXC3 OTD	28006385	5,000 K	750/359	-	9,671 lm	1,500 mA	35.6 V	39.5 V	-	-	176 lm/W	>70
RLE 2x6 4500lm 835 HP HE NTC EXC3 OTD	28006386	3,500 K	835/359	-	8,387 lm	1,500 mA	35.6 V	39.5 V	-	-	152 lm/W	>80
RLE 2x6 4500lm 850 HP HE NTC EXC3 OTD	28006712	5,000 K	850/359	-	8,729 lm	1,500 mA	35.6 V	39.5 V	-	-	159 lm/W	>80
RLE 2x8 6000lm 722 HP HE NTC EXC3 OTD	28006181	2,200 K	722/359	-	10,384 lm	1,500 mA	47.5 V	52.6 V	-	-	141 lm/W	>70
RLE 2x8 6000lm 727 HP HE NTC EXC3 OTD	28006182	2,700 K	727/359	-	11,468 lm	1,500 mA	47.5 V	52.6 V	-	-	156 lm/W	>70
RLE 2x8 6000lm 730 HP HE NTC EXC3 OTD	28006183	3,000 K	730/359	-	12,381 lm	1,500 mA	47.5 V	52.6 V	-	-	169 lm/W	>70
RLE 2x8 6000lm 735 HP HE NTC EXC3 OTD	28006377	3,500 K	735/359	-	12,552 lm	1,500 mA	47.5 V	52.6 V	-	-	171 lm/W	>70
RLE 2x8 6000lm 740 HP HE NTC EXC3 OTD	28006184	4,000 K	740/359	-	12,837 lm	1,500 mA	47.5 V	52.6 V	-	-	175 lm/W	>70
RLE 2x8 6000lm 750 HP HE NTC EXC3 OTD	28006378	5,000 K	750/359	-	12,894 lm	1,500 mA	47.5 V	52.6 V	-	-	176 lm/W	>70
RLE 2x8 6000lm 765 HP HE NTC EXC3 OTD	28006185	6,500 K	765/359	-	12,438 lm	1,500 mA	47.5 V	52.6 V	-	-	169 lm/W	>70
RLE 2x8 6000lm 822 HP HE NTC EXC3 OTD	28006186	2,200 K	822/359	-	9,813 lm	1,500 mA	47.5 V	52.6 V	-	-	134 lm/W	>80
RLE 2x8 6000lm 827 HP HE NTC EXC3 OTD	28006187	2,700 K	827/359	-	10,498 lm	1,500 mA	47.5 V	52.6 V	-	-	143 lm/W	>80

Type	Article number	Colour temperature	Photometric code	Useful luminous flux at tp = 25 °C	Expected luminous flux at tp rated	Typ. forward current	Min. forward voltage at tp rated	Max. forward voltage at tp = 25 °C	Power consumption Pon at tp = 25 °C	Efficacy of the module at tp = 25 °C	Expected efficacy of the module at tp rated	Colour rendering index CRI
RLE 2x8 6000lm 830 HP HE NTC EXC3 OTD	28006188	3,000 K	830/359	-	11,012 lm	1,500 mA	47.5 V	52.6 V	-	-	150 lm/W	>80
RLE 2x8 6000lm 835 HP HE NTC EXC3 OTD	28006379	3,500 K	835/359	-	11,183 lm	1,500 mA	47.5 V	52.6 V	-	-	152 lm/W	>80
RLE 2x8 6000lm 840 HP HE NTC EXC3 OTD	28006189	4,000 K	840/359	-	11,582 lm	1,500 mA	47.5 V	52.6 V	-	-	158 lm/W	>80
RLE 2x8 6000lm 850 HP HE NTC EXC3 OTD	28006711	5,000 K	850/359	-	11,639 lm	1,500 mA	47.5 V	52.6 V	-	-	159 lm/W	>80

① Lens shape like LEDIL Strada 2x2.

② Integral measurement over the complete module.

③ The detailed explanation, see data sheet section 1.1.

④ Tolerance of useful light flux - 0 % / + 15 %. Measurement uncertainty ± 10 %.

⑤ Measurement uncertainty ± 10 %. Based on calculation.

⑥ Tolerance of power consumption Pon ± 10 %. Measurement uncertainty ± 5 %.

1. Standards

EC 62031
IEC 62778
IEC 62471
IEC 61000-4-2
IEC 60068-2-52
UL 8750 (for dry and damp locations)
GR-1217-CORE

1.1 Photometric code

Key for photometric code, e. g. 830 / 579

1 st digit	2 nd + 3 rd digit	4 th digit	5 th digit	6 th digit
Code CRI	Colour temperature in Kelvin x 100	MacAdam initial	MacAdam after 25% of the lifetime (max.6000h)	Luminous flux after 25% of the lifetime (max.6000h)
7 70 – 79				Code Luminous flux
8 80 – 89				7 ≥ 70 %
9 ≥90				8 ≥ 80 %
				9 ≥ 90 %

1.2 Energy classification

Type	Colour temperature	Forward current	Energy classification	Energy consumption
RLE 2x4 3000lm xxx HP HE (NTC) EXC3 OTD				
RLE 2x4 3000lm 722 HP HE EXC3 OTD	2,200 K	700 mA	D	17 kWh / 1,000 h
RLE 2x4 3000lm 727 HP HE EXC3 OTD	2,700 K	700 mA	C	17 kWh / 1,000 h
RLE 2x4 3000lm 730 HP HE EXC3 OTD	3,000 K	700 mA	B	17 kWh / 1,000 h
RLE 2x4 3000lm 735 HP HE EXC3 OTD	3,500 K	700 mA	B	17 kWh / 1,000 h
RLE 2x4 3000lm 740 HP HE EXC3 OTD	4,000 K	700 mA	B	17 kWh / 1,000 h
RLE 2x4 3000lm 750 HP HE EXC3 OTD	5,000 K	700 mA	B	17 kWh / 1,000 h
RLE 2x4 3000lm 765 HP HE EXC3 OTD	6,500 K	700 mA	C	17 kWh / 1,000 h
RLE 2x4 3000lm 822 HP HE EXC3 OTD	2,200 K	700 mA	D	17 kWh / 1,000 h
RLE 2x4 3000lm 827 HP HE EXC3 OTD	2,700 K	700 mA	D	17 kWh / 1,000 h
RLE 2x4 3000lm 830 HP HE EXC3 OTD	3,000 K	700 mA	C	17 kWh / 1,000 h
RLE 2x4 3000lm 835 HP HE EXC3 OTD	3,500 K	700 mA	C	17 kWh / 1,000 h
RLE 2x4 3000lm 840 HP HE EXC3 OTD	4,000 K	700 mA	C	17 kWh / 1,000 h
RLE 2x4 3000lm 850 HP HE EXC3 OTD	5,000 K	700 mA	C	17 kWh / 1,000 h
RLE 2x6 4500lm xxx HP HE (NTC) EXC3 OTD				
RLE 2x6 4500lm 722 HP HE EXC3 OTD	2,200 K	700 mA	D	25 kWh / 1,000 h
RLE 2x6 4500lm 727 HP HE EXC3 OTD	2,700 K	700 mA	C	25 kWh / 1,000 h
RLE 2x6 4500lm 730 HP HE EXC3 OTD	3,000 K	700 mA	B	25 kWh / 1,000 h
RLE 2x6 4500lm 735 HP HE EXC3 OTD	3,500 K	700 mA	B	25 kWh / 1,000 h
RLE 2x6 4500lm 740 HP HE EXC3 OTD	4,000 K	700 mA	B	25 kWh / 1,000 h
RLE 2x6 4500lm 750 HP HE EXC3 OTD	5,000 K	700 mA	B	25 kWh / 1,000 h
RLE 2x6 4500lm 835 HP HE EXC3 OTD	3,500 K	700 mA	C	25 kWh / 1,000 h
RLE 2x6 4500lm 850 HP HE EXC3 OTD	5,000 K	700 mA	C	25 kWh / 1,000 h

Type	Colour temperature	Forward current	Energy classification	Energy consumption
RLE 2x8 6000lm xxx HP HE (NTC) EXC3 OTD				
RLE 2x8 6000lm 722 HP HE EXC3 OTD	2,200 K	700 mA	D	33 kWh / 1,000 h
RLE 2x8 6000lm 727 HP HE EXC3 OTD	2,700 K	700 mA	C	33 kWh / 1,000 h
RLE 2x8 6000lm 730 HP HE EXC3 OTD	3,000 K	700 mA	B	33 kWh / 1,000 h
RLE 2x8 6000lm 735 HP HE EXC3 OTD	3,500 K	700 mA	B	33 kWh / 1,000 h
RLE 2x8 6000lm 740 HP HE EXC3 OTD	4,000 K	700 mA	B	33 kWh / 1,000 h
RLE 2x8 6000lm 750 HP HE EXC3 OTD	5,000 K	700 mA	B	33 kWh / 1,000 h
RLE 2x8 6000lm 765 HP HE EXC3 OTD	6,500 K	700 mA	C	33 kWh / 1,000 h
RLE 2x8 6000lm 822 HP HE EXC3 OTD	2,200 K	700 mA	D	33 kWh / 1,000 h
RLE 2x8 6000lm 827 HP HE EXC3 OTD	2,700 K	700 mA	D	33 kWh / 1,000 h
RLE 2x8 6000lm 830 HP HE EXC3 OTD	3,000 K	700 mA	C	33 kWh / 1,000 h
RLE 2x8 6000lm 835 HP HE EXC3 OTD	3,500 K	700 mA	C	33 kWh / 1,000 h
RLE 2x8 6000lm 840 HP HE EXC3 OTD	4,000 K	700 mA	C	33 kWh / 1,000 h
RLE 2x8 6000lm 840 HP HE EXC3 OTD	4,000 K	700 mA	C	33 kWh / 1,000 h
RLE 2x8 6000lm 850 HP HE EXC3 OTD	5,000 K	700 mA	C	33 kWh / 1,000 h

Energy label and further information at www.tridonic.com in the certificates tab of the corresponding product page and at the EPREL data base <https://eprel.ec.europa.eu/>

2. Thermal details

2.1 tc point, ambient temperature and lifetime

The temperature at tp reference point is crucial for the light output and lifetime of a LED product.

For RLE a tp temperature of 75 °C has to be complied in order to achieve an optimum between heat sink requirements, light output and lifetime.

Compliance with the maximum permissible reference temperature at the tc point must be checked under operating conditions in a thermally stable state. The maximum value must be determined under worst-case conditions for the relevant application.

The tc and tp temperature of LED modules from Tridonic are measured at the same reference point.

2.2 Storage and humidity

Storage temperature	-40 ... +80 °C
---------------------	----------------

Operation only in non condensing environment.

Humidity during processing of the module should be between 0 to 70 %.

2.3 Thermal design and heat sink

The rated life of LED products depends to a large extent on the temperature. If the permissible temperature limits are exceeded, the life of the RLE will be greatly reduced or the RLE may be destroyed.

2.4 Heat sink values

RLE 2x4 3000lm EXC3 OTD

ta	tp	Forward current	R _{th, hs-a}	Cooling area
25°C	75°C	400 mA	1293 K/W	52 cm ²
25°C	75°C	700 mA	6.49 K/W	103 cm ²
25°C	75°C	1500 mA	2.51 K/W	265 cm ²
35°C	75°C	400 mA	10.34 K/W	64 cm ²
35°C	75°C	700 mA	5.19 K/W	128 cm ²
35°C	75°C	1500 mA	2.01 K/W	332 cm ²
40°C	75°C	400 mA	9.05 K/W	74 cm ²
40°C	75°C	700 mA	4.54 K/W	147 cm ²
40°C	75°C	1500 mA	1.75 K/W	380 cm ²
45°C	75°C	400 mA	7.75 K/W	86 cm ²
45°C	75°C	700 mA	3.89 K/W	171 cm ²
45°C	75°C	1500 mA	1.50 K/W	444 cm ²
50°C	75°C	400 mA	6.46 K/W	103 cm ²
50°C	75°C	700 mA	3.24 K/W	206 cm ²
50°C	75°C	1500 mA	1.25 K/W	533 cm ²
55°C	75°C	400 mA	5.17 K/W	129 cm ²
55°C	75°C	700 mA	2.59 K/W	257 cm ²
55°C	75°C	1500 mA	1.00 K/W	668 cm ²
60°C	75°C	400 mA	3.87 K/W	172 cm ²
60°C	75°C	700 mA	1.94 K/W	344 cm ²
60°C	75°C	1500 mA	0.75 K/W	894 cm ²

RLE 2x6 4500lm EXC3 OTD

ta	tp	Forward current	R _{th, hs-a}	Cooling area
25°C	75°C	400 mA	8.04 K/W	83 cm ²
25°C	75°C	700 mA	4.12 K/W	162 cm ²
25°C	75°C	1500 mA	1.59 K/W	419 cm ²
35°C	75°C	400 mA	6.43 K/W	104 cm ²
35°C	75°C	700 mA	3.30 K/W	202 cm ²
35°C	75°C	1500 mA	1.27 K/W	525 cm ²
40°C	75°C	400 mA	5.63 K/W	118 cm ²
40°C	75°C	700 mA	2.88 K/W	231 cm ²
40°C	75°C	1500 mA	1.11 K/W	600 cm ²
45°C	75°C	400 mA	4.82 K/W	138 cm ²
45°C	75°C	700 mA	2.47 K/W	270 cm ²
45°C	75°C	1500 mA	0.95 K/W	701 cm ²
50°C	75°C	400 mA	4.02 K/W	166 cm ²
50°C	75°C	700 mA	2.06 K/W	324 cm ²
50°C	75°C	1500 mA	0.79 K/W	842 cm ²
55°C	75°C	400 mA	3.21 K/W	208 cm ²
55°C	75°C	700 mA	1.64 K/W	406 cm ²
55°C	75°C	1500 mA	0.63 K/W	1056 cm ²
60°C	75°C	400 mA	2.41 K/W	277 cm ²
60°C	75°C	700 mA	1.23 K/W	542 cm ²
60°C	75°C	1500 mA	0.47 K/W	1413 cm ²

RLE 2x8 6000lm EXC3 OTD

ta	tp	Forward current	R _{th, hs-a}	Cooling area
25°C	75°C	400 mA	6.50 K/W	103 cm ²
25°C	75°C	700 mA	3.29 K/W	202 cm ²
25°C	75°C	1500 mA	1.26 K/W	531 cm ²
35°C	75°C	400 mA	5.20 K/W	128 cm ²
35°C	75°C	700 mA	2.63 K/W	253 cm ²
35°C	75°C	1500 mA	1.00 K/W	665 cm ²
40°C	75°C	400 mA	4.55 K/W	147 cm ²
40°C	75°C	700 mA	2.30 K/W	290 cm ²
40°C	75°C	1500 mA	0.88 K/W	760 cm ²
45°C	75°C	400 mA	3.90 K/W	171 cm ²
45°C	75°C	700 mA	1.97 K/W	338 cm ²
45°C	75°C	1500 mA	0.75 K/W	888 cm ²
50°C	75°C	400 mA	3.25 K/W	205 cm ²
50°C	75°C	700 mA	1.64 K/W	406 cm ²
50°C	75°C	1500 mA	0.62 K/W	1067 cm ²
55°C	75°C	400 mA	2.60 K/W	257 cm ²
55°C	75°C	700 mA	1.31 K/W	508 cm ²
55°C	75°C	1500 mA	0.50 K/W	1337 cm ²
60°C	75°C	400 mA	1.95 K/W	342 cm ²
60°C	75°C	700 mA	0.98 K/W	678 cm ²
60°C	75°C	1500 mA	0.37 K/W	1790 cm ²

Notes

The actual cooling surface can differ because of the material, the structural shape, outside influences and the installation situation. Depending on the heat sink a heat conducting paste or heat conducting film might be necessary to keep the specified tp temperature.

3. Installation / wiring

3.1 Electrical supply/choice of LED driver

RLE modules from Tridonic are not protected against overvoltages, overcurrents, overloads or short-circuit currents. Safe and reliable operation can only be guaranteed in conjunction with a LED driver which complies with the relevant standards. The use of LED driver from Tridonic in combination with RLE modules guarantees the necessary protection for safe and reliable operation.

If a LED driver other than Tridonic is used, it must provide the following protection:

- Short-circuit protection
- Overload protection
- Overtemperature protection



RLE modules must be supplied by a constant current LED driver. Operation with a constant voltage LED driver will lead to an irreversible damage of the module.

The max. permissible output current of the LED driver for parallel wiring is 1.8 A.

If RLE modules are wired in parallel and a wire breaks or a complete module fails then the current passing through the other module increases. This may reduce its life considerably. In addition there can be slight differences in light output caused by tolerances.

RLE modules can be operated either from SELV LED drivers or from LED drivers with LV output voltage.



RLE modules are basic insulated up to 670 V if mounted with M3 screws and lens (e.g. LEDiL Strada 2x2) against ground and can be mounted directly on earthed metal parts of the luminaire. If the max. output voltage of the LED driver (also against earth) is above 670 V, an additional insulation between LED module and heat sink is required (for example by insulated thermal pads) or by a suitable luminaire construction.

At voltages > 60 V an additional protection against direct touch (test finger) to the light emitting side of the module has to be guaranteed. This is typically achieved by means of a non removable light distributor over the module.

3.2 Integrated protection

The basic protection level consists of protection against reverse polarity and an NTC for overtemperature protection of the module.

The NTC is designed to work with the LCO EXC3 drivers supporting NTC functionality (for more details see LED driver data sheet).

NTC type: 100kΩ / 4100K

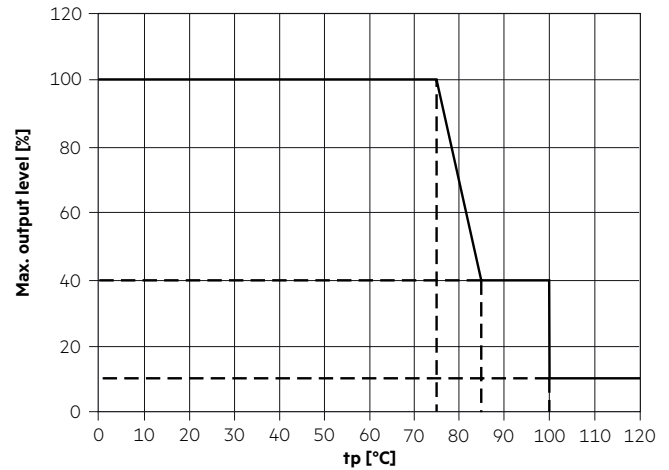

3.3 Wiring



3.4 Wiring examples

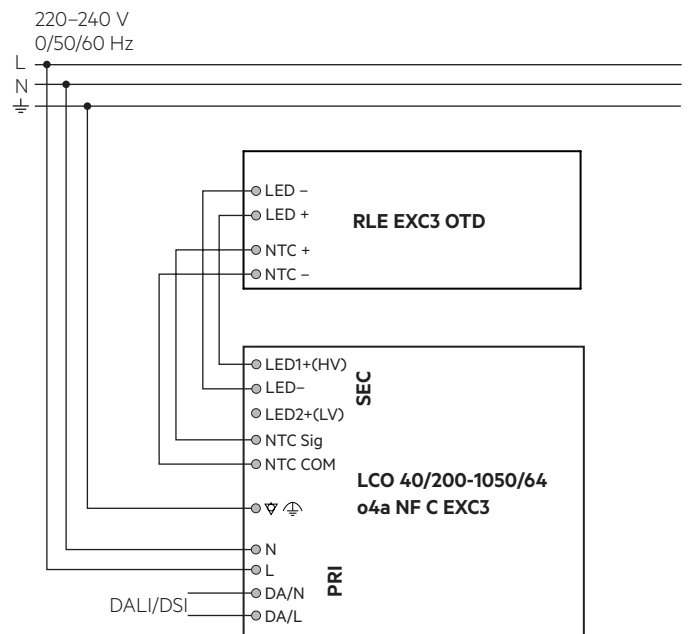

3.5 Wiring type and cross section

For wiring use stranded wire with ferrules or solid wire from 0.2 to 0.75 mm².
For the push-wire connection you have to strip the insulation (7–9 mm).

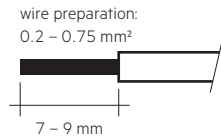

Inserting stranded wires / removing wires by lightly pressing on the push button.

3.6 Mounting instruction



None of the components of the RLE (substrate, LED, electronic components etc.) may be exposed to tensile or compressive stresses.

Max. torque for fixing: 0.5 Nm.

The LED modules are mounted onto a heat sink with M3 screws per module.



Chemical substance may harm the LED module. Chemical reactions could lead to colour shift, reduced luminous flux or a total failure of the module caused by corrosion of electrical connections.

Materials which are used in LED applications (e.g. sealings, adhesives) must not produce dissolver gas. They must not be condensation curing based, acetate curing based or contain sulfur, chlorine or phthalate.

Avoid corrosive atmosphere during usage and storage.

3.7 EOS/ESD safety guidelines



The device / module contains components that are sensitive to electrostatic discharge and may only be installed in the factory and on site if appropriate EOS/ESD protection measures have been taken. No special measures need be taken for devices/modules with enclosed casings (contact with the pc board not possible), just normal installation practice. Please note the requirements set out in the document EOS / ESD guidelines (Guideline_EOS_ESD.pdf) at: <http://www.tridonic.com/esd-protection>

4. Lifetime

4.1 Lifetime, lumen maintenance and failure rate

The light output of an LED module decreases over the lifetime, this is characterized with the L value.

L70 means that the LED module will give 70 % of its initial luminous flux. This value is always related to the number of operation hours and therefore defines the lifetime of an LED module.

As the L value is a statistical value and the lumen maintenance may vary over the delivered LED modules.

The B value defines the amount of modules which are below the specific L value, e.g. L70B10 means 10 % of the LED modules are below 70 % of the initial luminous flux, respectively 90 % will be above 70 % of the initial value. In addition the percentage of failed modules (fatal failure) is characterized by the C value.

4.2 Lumen maintenance

Typ. forward current	tp temperature	L90 / B10	L90 / B50	L80 / B10	L80 / B50	L70 / B10	L70 / B50
400 mA	55 °C	>102k h	>102k h	>102k h	>102k h	>102k h	>102k h
	60 °C	>102k h	>102k h	>102k h	>102k h	>102k h	>102k h
	65 °C	>102k h	>102k h	>102k h	>102k h	>102k h	>102k h
	70 °C	>102k h	>102k h	>102k h	>102k h	>102k h	>102k h
	75 °C	101k h	>102k h	>102k h	>102k h	>102k h	>102k h
	80 °C	100k h	>102k h	>102k h	>102k h	>102k h	>102k h
	85 °C	100k h	>102k h	>102k h	>102k h	>102k h	>102k h
	90 °C	86k h	91k h	>102k h	>102k h	>102k h	>102k h
	95 °C	75k h	78k h	>102k h	>102k h	>102k h	>102k h
	1,500 mA	55 °C	>102k h	>102k h	>102k h	>102k h	>102k h
60 °C		>102k h	>102k h	>102k h	>102k h	>102k h	>102k h
65 °C		>102k h	>102k h	>102k h	>102k h	>102k h	>102k h
70 °C		>102k h	>102k h	>102k h	>102k h	>102k h	>102k h
75 °C		101k h	>102k h	>102k h	>102k h	>102k h	>102k h
80 °C		100k h	>102k h	>102k h	>102k h	>102k h	>102k h
85 °C		100k h	>102k h	>102k h	>102k h	>102k h	>102k h
90 °C		86k h	91k h	>102k h	>102k h	>102k h	>102k h
95 °C		75k h	78k h	>102k h	>102k h	>102k h	>102k h

L00C03 >102k h. At tp rated and Irated, based on 10 switching cycles per day.

4.3 Switching capability

100,000 cycles

Test according to IEC 62717 Cl 10.3.3

30 s on / 30 s off at a forward current of 1000 mA

5. Electrical values

5.1 Typ. forward voltage vs. forward current

RLE 2x4 3000lm xxx HP EXC3 OTD

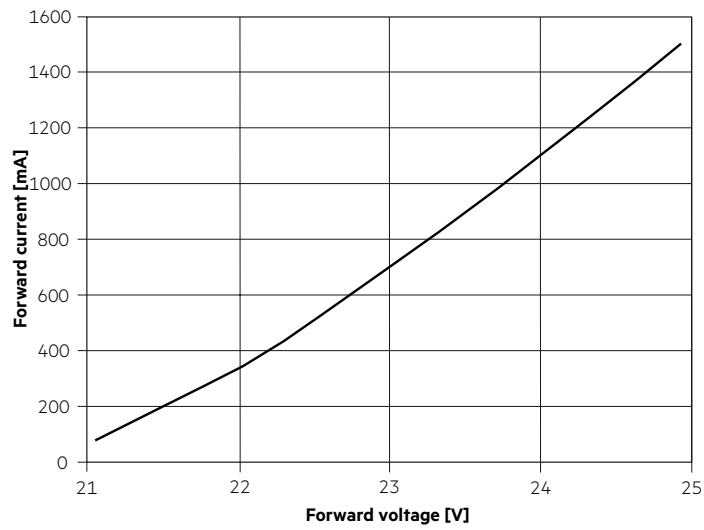

RLE 2x6 4500lm xxx HP EXC3 OTD

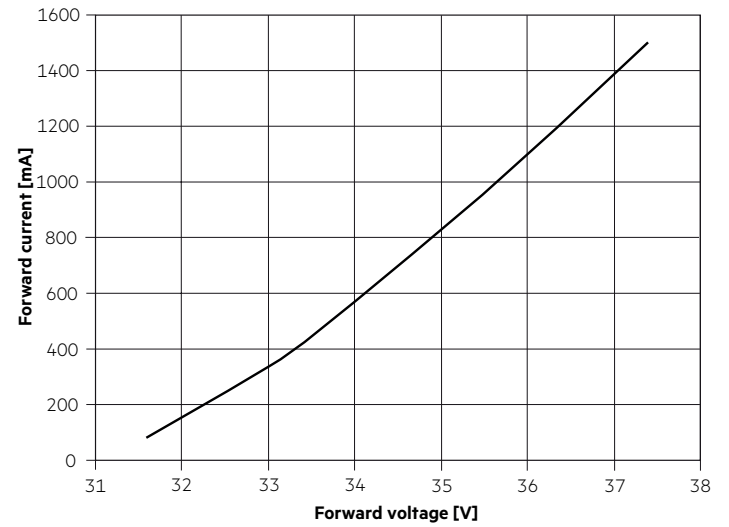

RLE 2x8 6000lm xxx HP EXC3 OTD

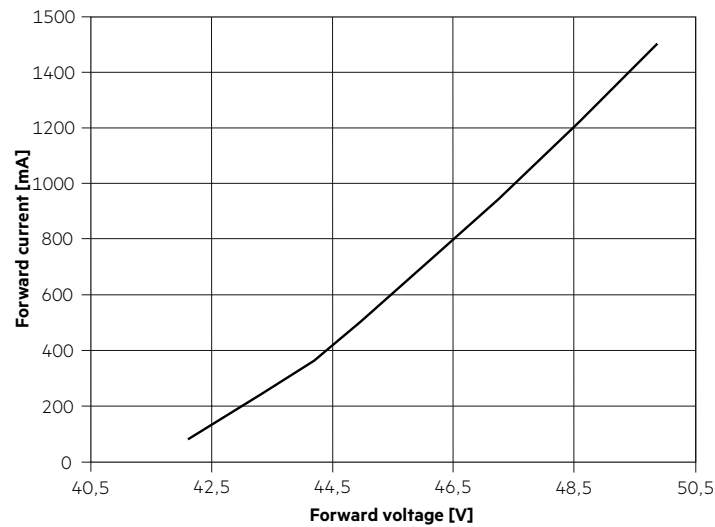

5.2 Forward voltage vs. tc temperature

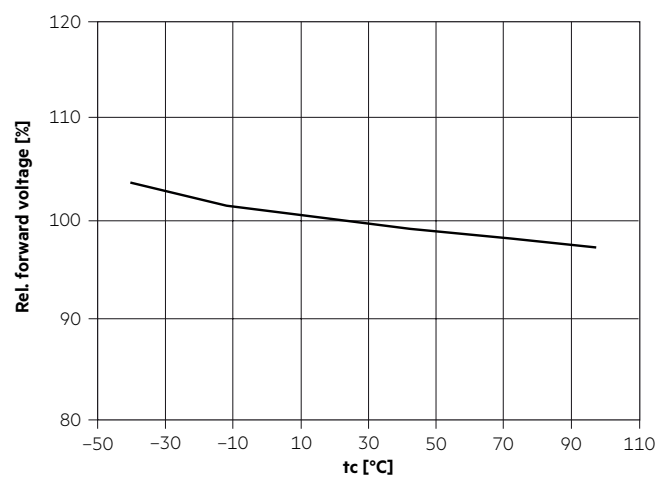

The diagrams are based on statistic values.
The real values can be different.

6. Photometric characteristics

6.1 Coordinates and tolerances according to CIE 1931

The specified colour coordinates are integral measured by current impulse of 360 mA and a duration of 100 ms.
 The ambient temperature of the measurement is 25 °C.
 The measurement tolerance of the colour coordinates are ± 0.01 .

2,200 K, CRI 70

	x0	y0
Centre	0.5020	0.4156

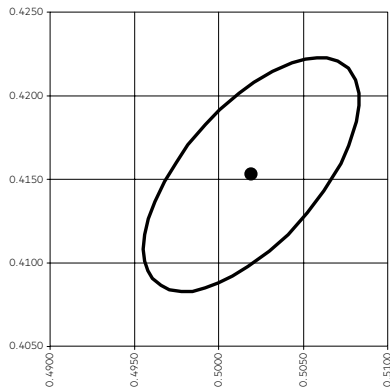

— MacAdam Ellipse: 3SDCM

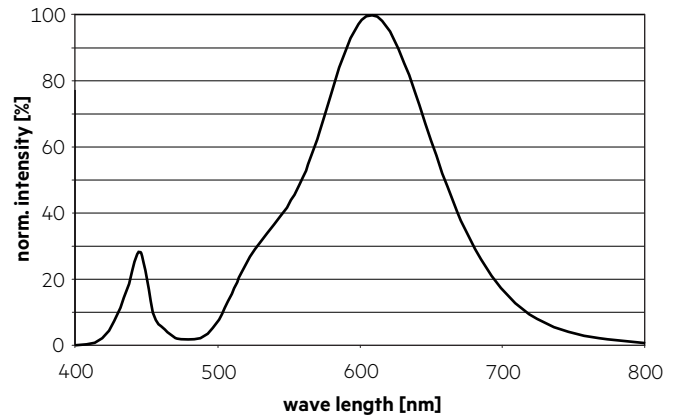

2,700 K, CRI 70

	x0	y0
Centre	0.4577	0.4098

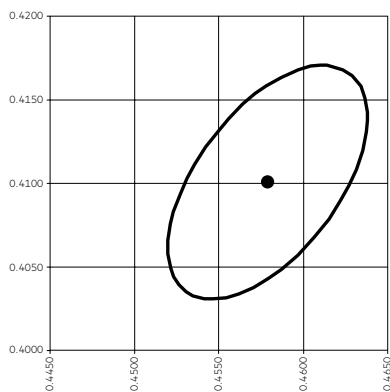

— MacAdam Ellipse: 3SDCM

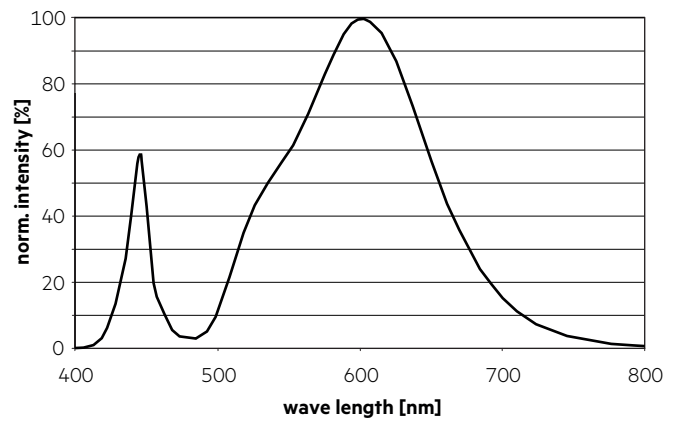

3,000 K, CRI 70

	x0	y0
Centre	0.4339	0.4032

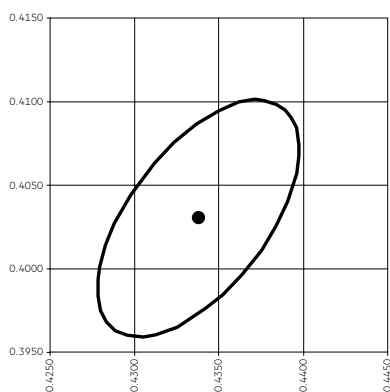

— MacAdam Ellipse: 3SDCM

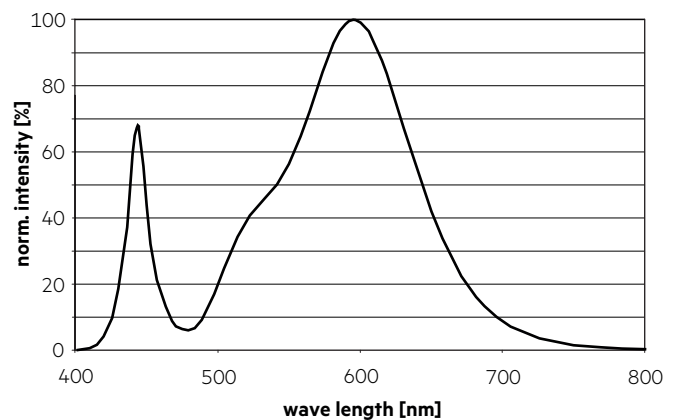

3,500 K, CRI 70

	x0	y0
Centre	0.4077	0.3929

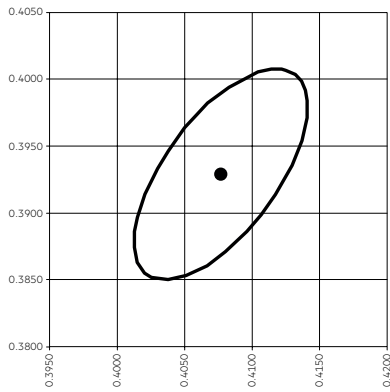

— MacAdam Ellipse: 3SDCM

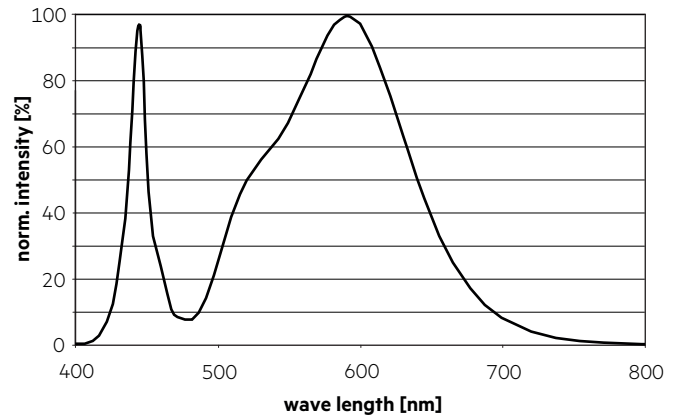

4,000 K, CRI 70

	x0	y0
Centre	0.3818	0.3796

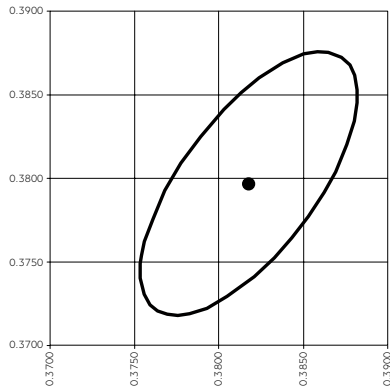

— MacAdam Ellipse: 3SDCM

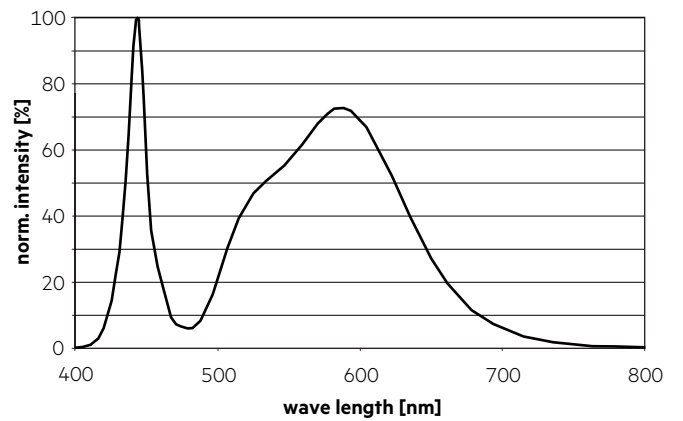

5,000 K, CRI 70

	x0	y0
Centre	0.3446	0.3551

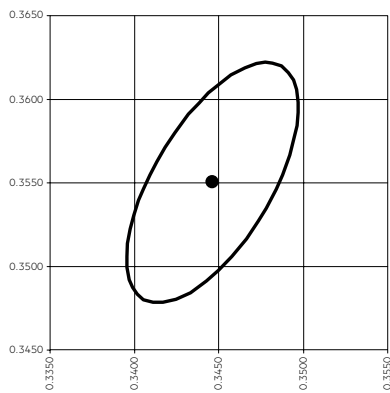

— MacAdam Ellipse: 3SDCM

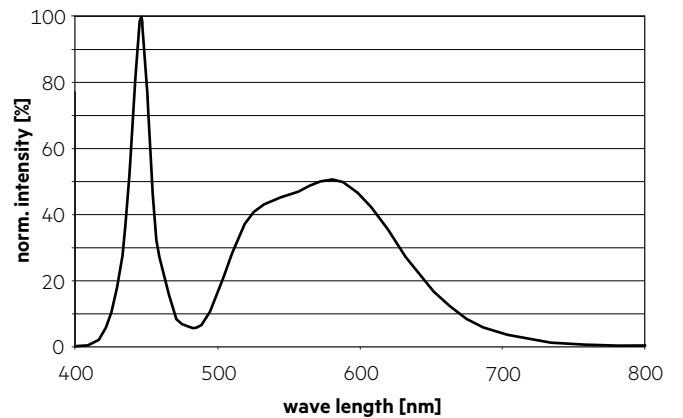

6,500 K, CRI 70

	x0	y0
Centre	0.3123	0.3285

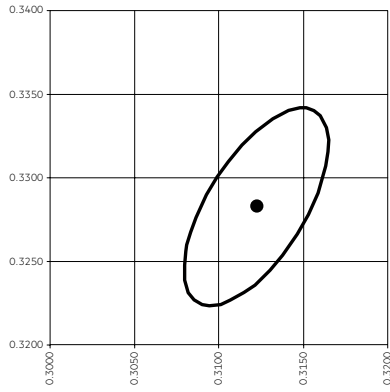

— MacAdam Ellipse: 3SDCM

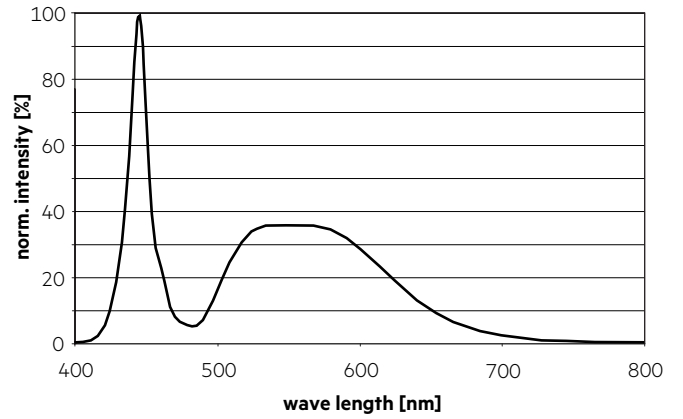

2,200 K, CRI 80

	x0	y0
Centre	0.5020	0.4156

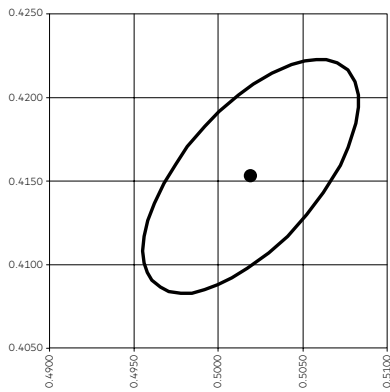

— MacAdam Ellipse: 3SDCM

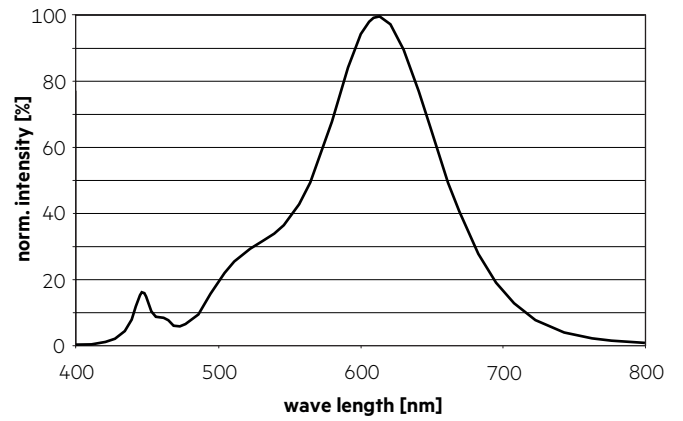

2,700 K, CRI 80

	x0	y0
Centre	0.4577	0.4098

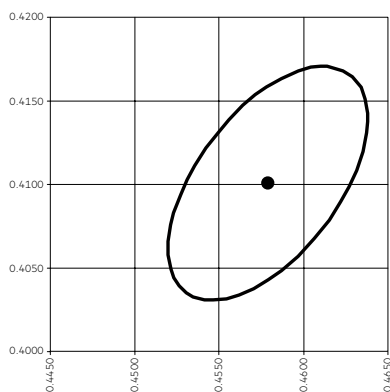

— MacAdam Ellipse: 3SDCM

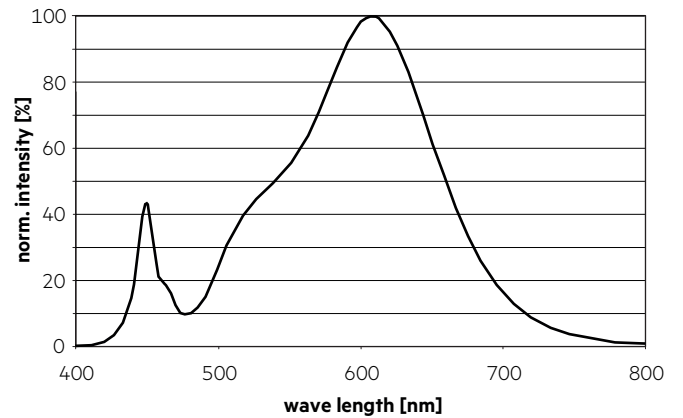

3,000 K, CRI 80

	x0	y0
Centre	0.4339	0.4032

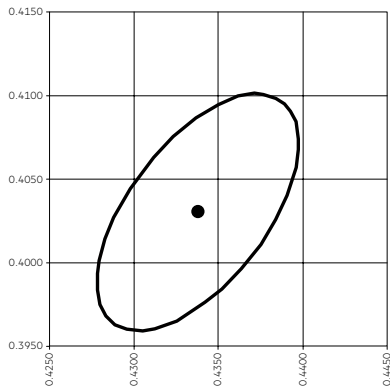

— MacAdam Ellipse: 3SDCM

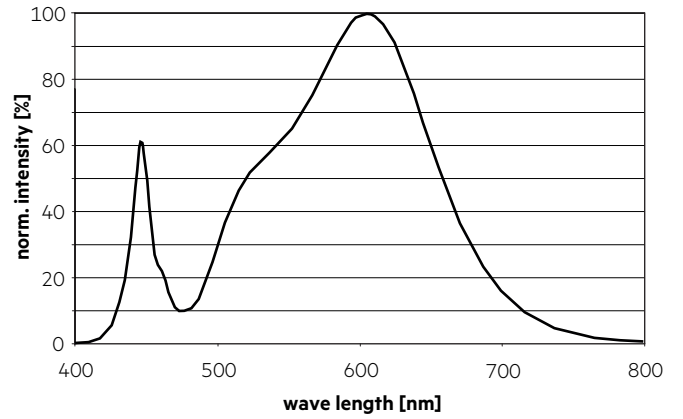

3,500 K, CRI 80

	x0	y0
Centre	0.4077	0.3929

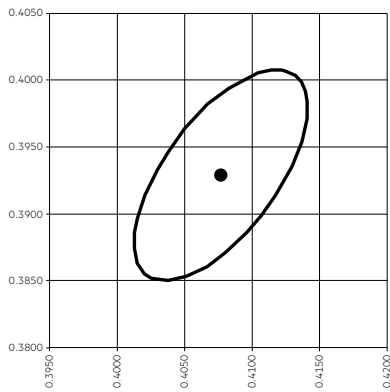

— MacAdam Ellipse: 3SDCM

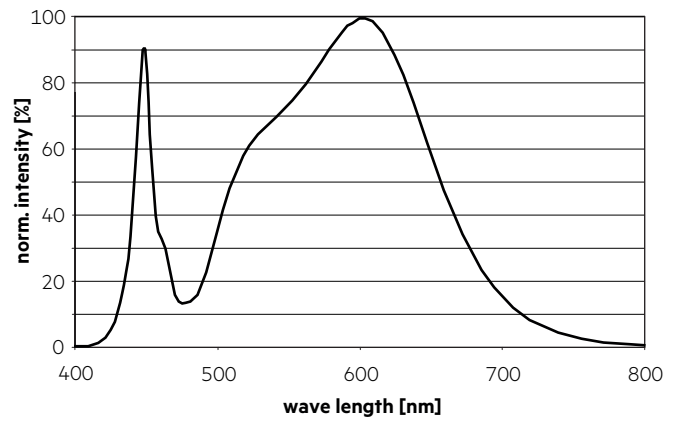

4,000 K, CRI 80

	x0	y0
Centre	0.3818	0.3796

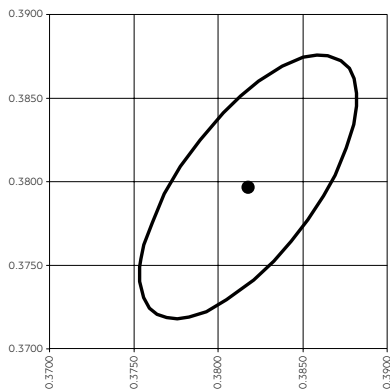

— MacAdam Ellipse: 3SDCM

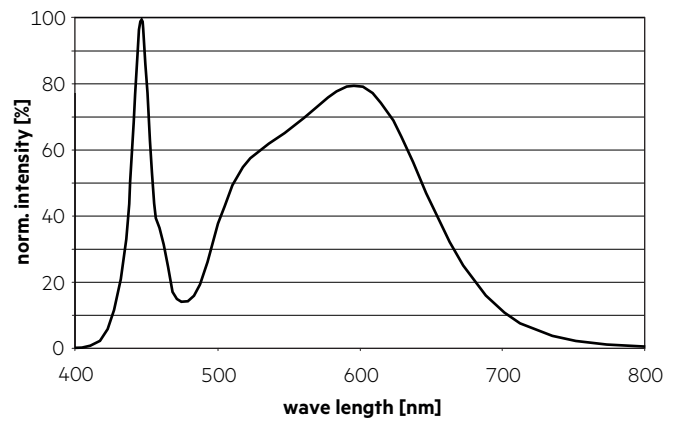

5,000 K, CRI 80

	x0	y0
Centre	0.3446	0.3551

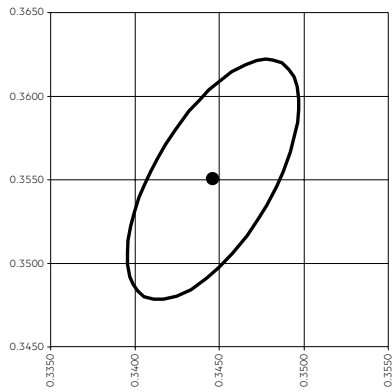

— MacAdam Ellipse: 3SDCM

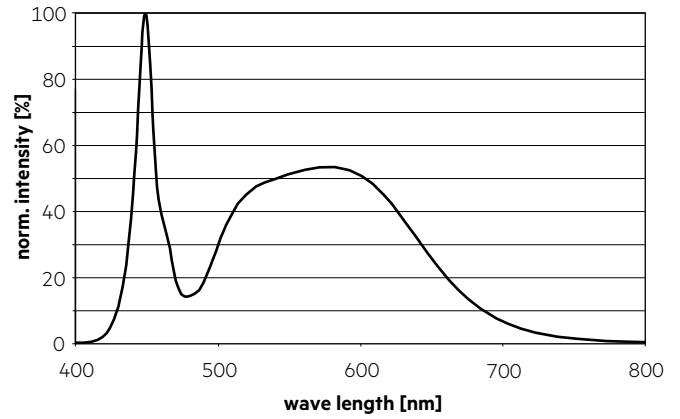

6.2 Spectral G-Index

CCT	CRI	G-Index
2,200 K	70	2.3
2,700 K	70	1.7
3,000 K	70	1.4
3,500 K	70	1.3
4,000 K	70	1.0
5,000 K	70	0.7
6,500 K	70	0.4
2,200 K	80	2.2
2,700 K	80	1.7
3,000 K	80	1.5
3,500 K	80	1.3
4,000 K	80	1.0
5,000 K	80	0.7

Based on typical spectral distribution measured at 25°C and Irated.

6.3 Light distribution

RLE modules are designed to be compatible with 50 x 50 mm lens arrays with 25.4 mm pitch distance. This allows multiple light distributions.

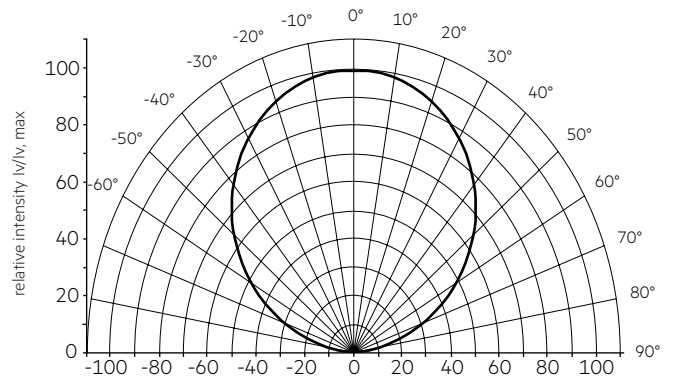

The colour temperature is measured integral over the complete module. The single LED light points can have deviations in the colour coordinates within MacAdam 4.

6.4 Relative luminous flux vs. tc temperature

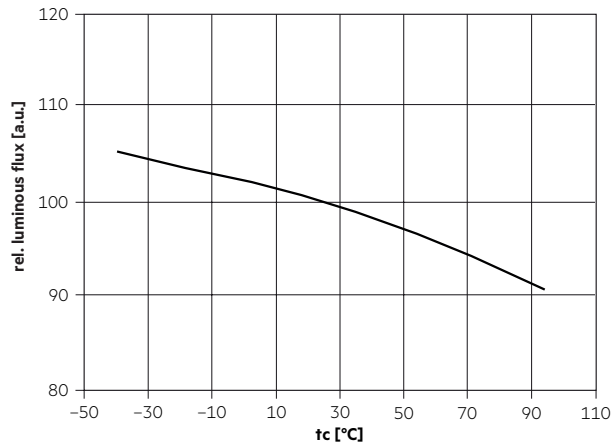

6.5 Relative luminous flux vs. operating current

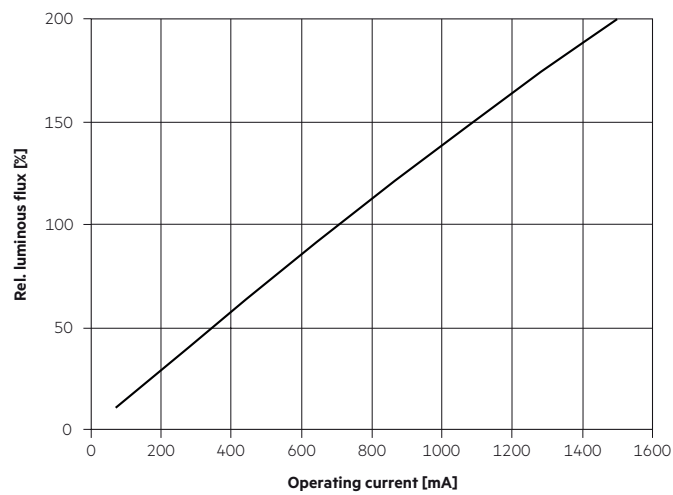

The diagrams are based on statistic values.
The real values can be different.

7. Miscellaneous

7.1 Additional information

Additional technical information at www.tridonic.com → Technical Data

Guarantee conditions at www.tridonic.com → Services

Lifetime declarations are informative and represent no warranty claim.