

**Module LLE G2 700lm premium**

Modules LLE premium



LLE G2 24x280MM 700LM 927-965 LV PRE



For articles manufactured at Tridonic SRB d.o.o.

**Product description**

- \_ Ideal for linear and panel lights
- \_ Optimal solution for Tunable White applications together with LCA PRE DT8 or 2 channel low profile LED drivers
- \_ SELV module – the single module has a forward voltage < 60 V
- \_ Push terminals for quick and simple wiring of LED module to LED module
- \_ Excellent thermal management
- \_ Long lifetime: 50,000 hours
- \_ 5 years guarantee (conditions at <https://www.tridonic.com/en/int/services/manufacturer-guarantee-conditions>)

**Optical properties**

- \_ Linear Tunable White LED module with 2,700 and 6,500 K SMT packages
- \_ Useful luminous flux 685 lm at Irated and tp = 25 °C
- \_ Efficacy of the LED module 127 lm/W at Irated and tp = 25 °C
- \_ High colour rendering index CRI > 90
- \_ Small colour tolerance (MacAdam 3) <sup>①</sup>
- \_ Low tolerances for luminous flux

**Mechanical properties**

- \_ Module dimension 24 x 280 mm (ZHAGA compliant)
- \_ Simple installation (e.g ACL push fix)

<sup>①</sup> Integral measurement over the complete module.

**Website**

<http://www.tridonic.com/89602922>



Linear



High bay



Decorative



Downlights



Spotlights



Free-standing



Area



Floor | Wall



Street

**Module LLE G2 700lm premium**

Modules LLE premium

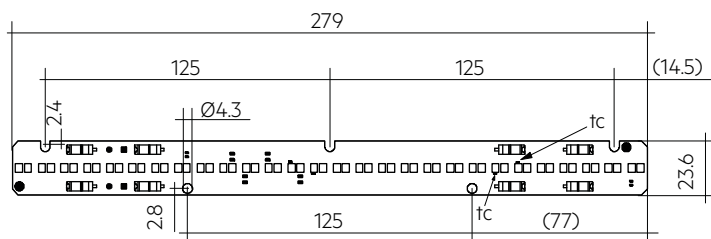

LLE G2 24x280MM 700LM 927-965 LV PRE

**Ordering data**

Type	Article number	Colour temperature	Packaging, carton	Weight per pc.
LLE G2 24x280mm 700lm 927-965 LV PRE	89602922	2,700 – 6,500 K	210 pc(s).	0.029 kg

**Technical data**

Beam characteristic	120°
Ambient temperature $t_a$ ②	-25 ... +55 °C
tp rated	65 °C
tc	85 °C
I <sub>rated</sub>	125 mA
I <sub>max</sub>	165 mA
Max. permissible LF current ripple	185 mA
Max. permissible peak current	240 mA / max. 10 ms
Max. working voltage for insulation SELV ③④	< 60 V
Insulation test voltage	0.5 kV
CTI of the printed circuit board	≥ 600
ESD classification	Severity level 1
Risk group (IEC 62471)	RG0
Classification acc. to IEC 62031	Built-in
Type of protection	IPO0
Lumen maintenance L70B50	50,000 h
Guarantee (conditions at www.tridonic.com)	5 Year(s)

**Approval marks**



**Standards**

EN 62031, EN 62471, EN 61347-1, EN 61547, EN 61000-4-6

**Specific technical data**

Type	Channel	Photometric code	Useful luminous flux at $t_p = 25\text{ °C}$ ④	Expected luminous flux at $t_p$ rated ④	Typ. forward current ③	Min. forward voltage at $t_p$ rated ③	Max. forward voltage at $t_p = 25\text{ °C}$ ③	Power consumption $P_{on}$ at $t_p = 25\text{ °C}$ ③	Efficacy of the module at $t_p = 25\text{ °C}$	Expected efficacy of the module at $t_p$ rated	Colour rendering index CRI
LLE G2 24x280mm 700lm 927-965 LV PRE	WW	927/349	685 lm	647 lm	125 mA	39.3 V	43.8 V	5.4 W	127 lm/W	122 lm/W	>90
LLE G2 24x280mm 700lm 927-965 LV PRE	CW	965/349	-	723 lm	125 mA	39.3 V	43.8 V	-	-	136 lm/W	>90

② Mounted with non-conductive element like ACL CLIP 4.3mm.

③ Tolerance range for electrical data: ±5 %.

④ Tolerance range for optical data over the CCT range: ±5 %.

LINEAR COVER LLE

Accessory



Product description

- \_ LINEAR COVER for LLE
- \_ Protection against direct touch for non-SELV applications (recommendation LLE 20: use all fixing points and screwed Endcap, recommendation LLE 24: use all fixing points)
- \_ Fast snap on mounting on to LLE 20: with M4 screws and plastic washers, to LLE 24: with clips or plastic washers
- \_ High transmission: transparent, semi-transparent and diffuse
- \_ Material: PMMA
- \_ Tolerances:  $\pm 1$  mm for 597 mm length (ends finished), + 10 mm from length 1,150 mm (ends raw)

Website

<http://www.tridonic.com/28000338>

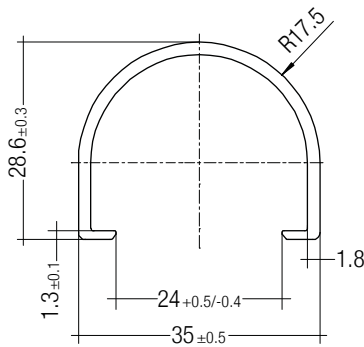

Ordering data

Type	Article number	Colour	Length L	Efficiency	Packaging, carton	Weight per pc.
LINEAR COVER SY Transparent 1600mm	28000338	Transparent	1,600 mm	94 %	12 pc(s).	0.272 kg
LINEAR COVER SY Frosted 1800mm	28000437	Semi-transparent	1,800 mm	87 %	12 pc(s).	0.308 kg
LINEAR COVER SY Frosted 1600mm	28000339	Semi-transparent	1,600 mm	87 %	12 pc(s).	0.272 kg
LINEAR COVER SY Frosted 1500mm	28000435	Semi-transparent	1,500 mm	87 %	12 pc(s).	0.244 kg
LINEAR COVER SY Frosted 1200mm	28000422	Semi-transparent	1,200 mm	87 %	12 pc(s).	0.205 kg
LINEAR COVER SY Frosted 597mm	28000340	Semi-transparent	597 mm	87 %	12 pc(s).	0.102 kg
LINEAR COVER SY Diffuse 1800mm	28000438	Diffuse	1,800 mm	76 %	12 pc(s).	0.308 kg
LINEAR COVER SY Diffuse 1600mm	28000341	Diffuse	1,600 mm	76 %	12 pc(s).	0.272 kg
LINEAR COVER SY Diffuse 1500mm	28000436	Diffuse	1,500 mm	76 %	12 pc(s).	0.257 kg
LINEAR COVER SY Diffuse 1200mm	28000434	Diffuse	1,200 mm	76 %	12 pc(s).	0.205 kg
LINEAR COVER SY Diffuse 597mm	28000342	Diffuse	597 mm	76 %	12 pc(s).	0.102 kg

ACL ENDCAP LLE

Accessory



Product description

- \_ ENDCAP for LLE
- \_ PUSH-FIX: Fast snap on mounting (sheet thickness 0.5 – 1.0 mm), for drilling hole 4 mm
- \_ SCREW-FIX: Screw mounting with EJOT Delta PT WN 5451 30x8 (not included), tightening torque 0.7 Nm
- \_ Clip made of polycarbonate

Website

<http://www.tridonic.com/28001037>

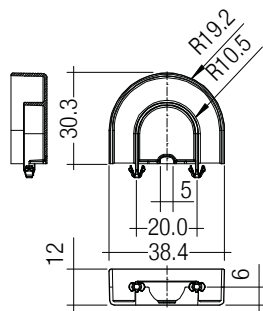

Ordering data

Type	Article number	Colour	Packaging, carton	Weight per pc.
ACL ENDCAP LLE24 PUSH-FIX	28001037	White	480 pc(s).	0.003 kg
ACL ENDCAP LLE24 SCREW-FIX	28002315	White	480 pc(s).	0.003 kg

ACL LINEAR LENS 24mm

Accessory



**Product description LINEAR LENS**

- \_ Linear lens for LLE 20 / 24
- \_ Available with different beam characteristics
- \_ Protection against direct touch for non-SELV applications (recommendation: use all fixing points)
- \_ Fast snap on mounting on to LLE 20: with M4 screws and plastic washers, to LLE 24: with clips or plastic washers
- \_ Recommendation: Fastening with screws and plastic washers, see 2.3 Heat sink specifications in data sheet
- \_ Material: PMMA
- \_ Available lengths: 1,200, 1,500 and 1,800 mm, Tolerance: + 10 mm (ends raw)
- \_ Max. permissible temperature 80 °C
- \_ Photometric data available on website

**Product description Endcap**

- \_ ENDCAP for LINEAR LENS 24mm INTENSE, ASY and DASY
- \_ Mounting by clipping in and screwing from below using screw EJOT Delta PT WN 5451 20x4, tightening torque 0.7 Nm
- \_ Made of Polyamide UL94 V0

**Website**

<http://www.tridonic.com/28001428>

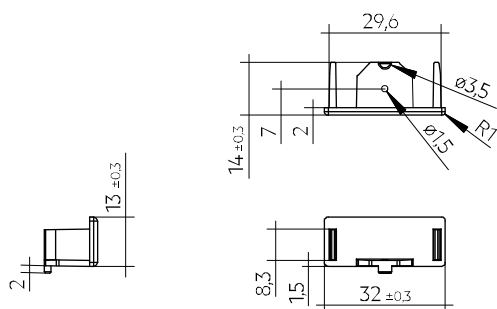

**Ordering data**

Type	Article number	Length L	Beam characteristic	Efficiency	Packaging, carton	Weight per pc.
ACL LINEAR LENS 24x1200mm 60°	28001428	1,200 mm	60°	97 %	21 pc(s).	0.196 kg
ACL LINEAR LENS 24x1200mm 90°	28001429	1,200 mm	90°	97 %	21 pc(s).	0.165 kg
ACL LINEAR LENS 24x1500mm 60°	28000953	1,500 mm	60°	97 %	21 pc(s).	0.261 kg
ACL LINEAR LENS 24x1500mm 90°	28000955	1,500 mm	90°	97 %	21 pc(s).	0.221 kg
ACL LINEAR LENS 24x1200mm INTENSE	28002024	1,200 mm	40°	95 %	18 pc(s).	0.261 kg
ACL LINEAR LENS 24x1500mm INTENSE	28002025	1,500 mm	40°	95 %	18 pc(s).	0.326 kg
ACL LINEAR LENS 24x1800mm INTENSE	28002026	1,800 mm	40°	95 %	18 pc(s).	0.392 kg
ACL LINEAR LENS 24x1200mm BATWING	28002027	1,200 mm	batwing	95 %	18 pc(s).	0.275 kg
ACL LINEAR LENS 24x1500mm BATWING	28002028	1,500 mm	batwing	95 %	18 pc(s).	0.344 kg
ACL LINEAR LENS 24x1800mm BATWING	28002029	1,800 mm	batwing	95 %	18 pc(s).	0.412 kg
ACL LINEAR LENS 24x1200mm ASY	28002030	1,200 mm	asymmetric	95 %	18 pc(s).	0.250 kg
ACL LINEAR LENS 24x1500mm ASY	28002031	1,500 mm	asymmetric	95 %	18 pc(s).	0.312 kg
ACL LINEAR LENS 24x1800mm ASY	28002032	1,800 mm	asymmetric	95 %	18 pc(s).	0.375 kg
ACL LINEAR LENS 24x1200mm DASY	28002033	1,200 mm	double asymmetric	92 %	18 pc(s).	0.249 kg
ACL LINEAR LENS 24x1500mm DASY	28002034	1,500 mm	double asymmetric	92 %	18 pc(s).	0.311 kg
ACL LINEAR LENS 24x1800mm DASY	28002035	1,800 mm	double asymmetric	92 %	18 pc(s).	0.373 kg
ACL Endcap LENS 24mm PSF	28002669	-	-	-	3,600 pc(s).	0.003 kg

ACL CLIP 4.3mm

Accessory



**Product description**

- \_ Clip for fixation of LED modules with 4.3 mm holes
- \_ Fast snap on mounting (sheet thickness 0.5 – 1.0 mm for PUSH-FIX and 1 – 2 mm for PUSH-FIX Long)
- \_ For drilling hole 4 mm
- \_ Clip made of polycarbonate
- \_ Minimum sales quantity 500 pcs.

**Website**

<http://www.tridonic.com/28001036>

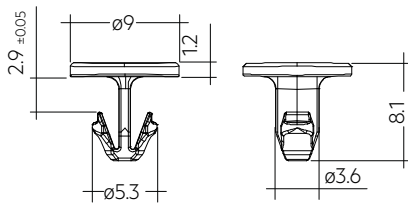

**Ordering data**

Type	Article number	Colour	Packaging, bag <sup>①</sup>	Weight per pc.
ACL CLIP 4.3mm PUSH-FIX	28001036	White	500 pc(s).	0.001 kg
ACL CLIP 4,3mm PUSH-FIX Long	28002314	Transparent	500 pc(s).	0.001 kg

① Minimum sales quantity 500 pcs.

## 1. Standards

EN 62031  
EN 62471  
EN 61347-1  
EN 61547  
EN 61000-4-6

### 1.1 Photometric code

Key for photometric code, e. g. 930 / 349

1 <sup>st</sup> digit	2 <sup>nd</sup> + 3 <sup>rd</sup> digit	4 <sup>th</sup> digit	5 <sup>th</sup> digit	6 <sup>th</sup> digit	
Code CRI	Colour temperature in Kelvin x 100	McAdam initial	McAdam after 25% of the lifetime (max.6000h)	Luminous flux after 25% of the lifetime (max.6000h)	
7 70 – 79				Code	Luminous flux
8 80 – 89				7	≥ 70 %
9 ≥90				8	≥ 80 %
				9	≥ 90 %

### 1.2 Energy classification

Type	Colour temperature	Forward current	Energy classification	Energy consumption
LLE G2 24x280MM 700LM 927-965 LV PRE	2,700 K	125 mA	E	6 kWh / 1,000 h

Energy label and further information at [www.tridonic.com](http://www.tridonic.com) in the certificates tab of the corresponding product page and at the EPREL data base <https://eprel.ec.europa.eu/>

## 2. Thermal details

### 2.1 tc point, ambient temperature and lifetime

The temperature at tp reference point is crucial for the light output and lifetime of a LED product.

For LLE a tp temperature of 65 °C has to be complied in order to achieve an optimum between heat sink requirements, light output and lifetime.

Compliance with the maximum permissible reference temperature at the tc point must be checked under operating conditions in a thermally stable state. The maximum value must be determined under worst-case conditions for the relevant application.

The tc and tp temperature of LED modules from Tridonic are measured at the same reference point.

### 2.2 Storage and humidity

Storage temperature	-30 ... +80 °C
---------------------	----------------

Operation only in non condensing environment.  
Humidity during processing of the module should be between 30 to 70 %.

### 2.3 Thermal design and heat sink

The rated life of LED products depends to a large extent on the temperature. If the permissible temperature limits are exceeded, the life of the LLE will be greatly reduced or the LLE may be destroyed.

Therefore the LLE needs to be mounted onto a heat sink.

Tridonic's excellent thermal design for the LED products provides the lowest thermal resistance and therefore allowing new compact designs without sacrificing quality, safety and lifetime.

## 2.4 Heat sink values

### LLE G2 24x280MM 700LM 927-965 LV PRE

ta	tp	Forward current	R <sub>th, hs-a</sub>	Cooling area
25 °C	65 °C	125 mA	11.8 K/W	57 cm <sup>2</sup>
35 °C	65 °C	125 mA	8.8 K/W	75 cm <sup>2</sup>
40 °C	65 °C	125 mA	7.4 K/W	90 cm <sup>2</sup>
45 °C	65 °C	125 mA	5.9 K/W	113 cm <sup>2</sup>
50 °C	65 °C	125 mA	4.4 K/W	151 cm <sup>2</sup>
55 °C	65 °C	125 mA	2.9 K/W	226 cm <sup>2</sup>
60 °C	65 °C	125 mA	1.4 K/W	454 cm <sup>2</sup>

### LLE G2 24x560MM 1400LM 927-965 LV PRE

ta	tp	Forward current	R <sub>th, hs-a</sub>	Cooling area
25 °C	65 °C	250 mA	6.10 K/W	109 cm <sup>2</sup>
35 °C	65 °C	250 mA	4.57 K/W	146 cm <sup>2</sup>
40 °C	65 °C	250 mA	3.81 K/W	175 cm <sup>2</sup>
45 °C	65 °C	250 mA	3.05 K/W	219 cm <sup>2</sup>
50 °C	65 °C	250 mA	2.28 K/W	292 cm <sup>2</sup>
55 °C	65 °C	250 mA	1.52 K/W	438 cm <sup>2</sup>
60 °C	65 °C	250 mA	0.76 K/W	878 cm <sup>2</sup>

## Notes

These values apply to a single LED module.

The actual cooling surface can differ because of the material, the structural shape, outside influences and the installation situation. The LED modules must rest flat on the heat sink.

## 3. Installation / wiring

### 3.1 Electrical supply/choice of LED driver

LLE modules must be operated with SELV LED drivers.



LLE modules are basic insulated up to 60 V SELV against ground and can be mounted directly on earthed metal parts of the luminaire. If the max. output voltage of the LED driver (also against earth) is above 60 V SELV, an additional insulation between LED module and heat sink is required (for example by insulated thermal pads) or by a suitable luminaire construction.

At voltages > 60 V an additional protection against direct touch (test finger) to the light emitting side of the module has to be guaranteed. This is typically achieved by means of a non removable light distributor over the module.

### 3.2 Wiring

#### Wiring diagram for switchDIM and colourSWITCH for LLE premium

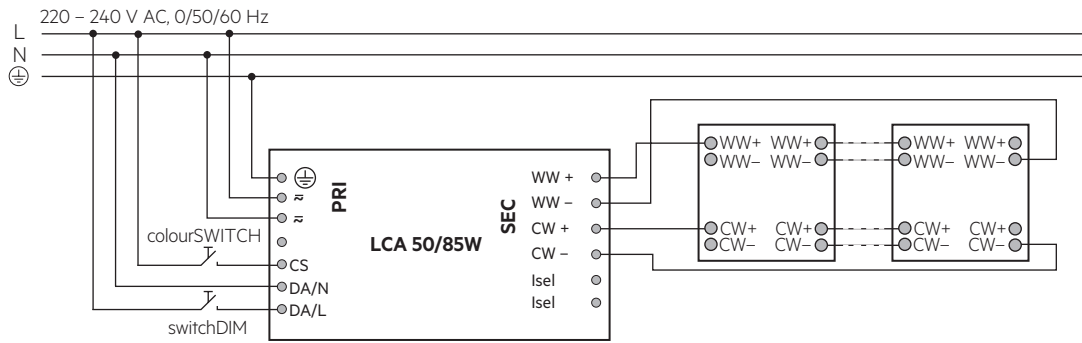

#### Wiring diagram for DALI for LLE premium

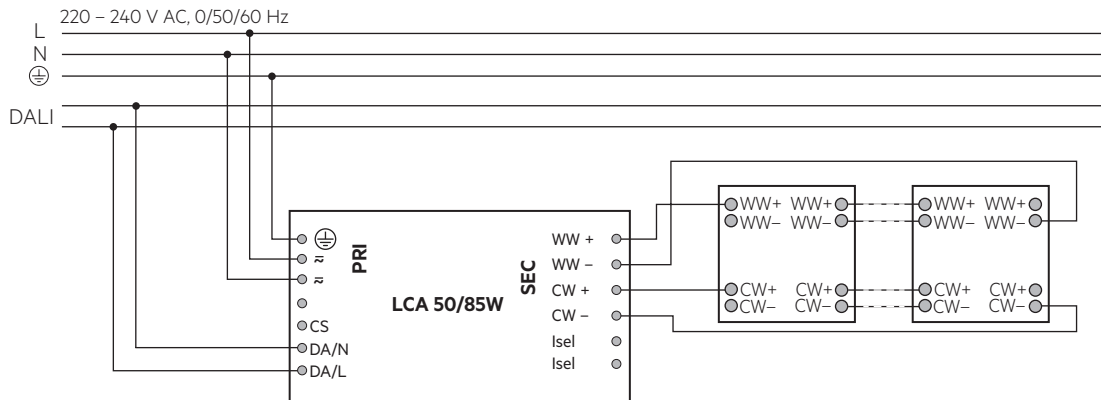

#### Wiring diagram for switchDIM and colourSWITCH for LLE premium

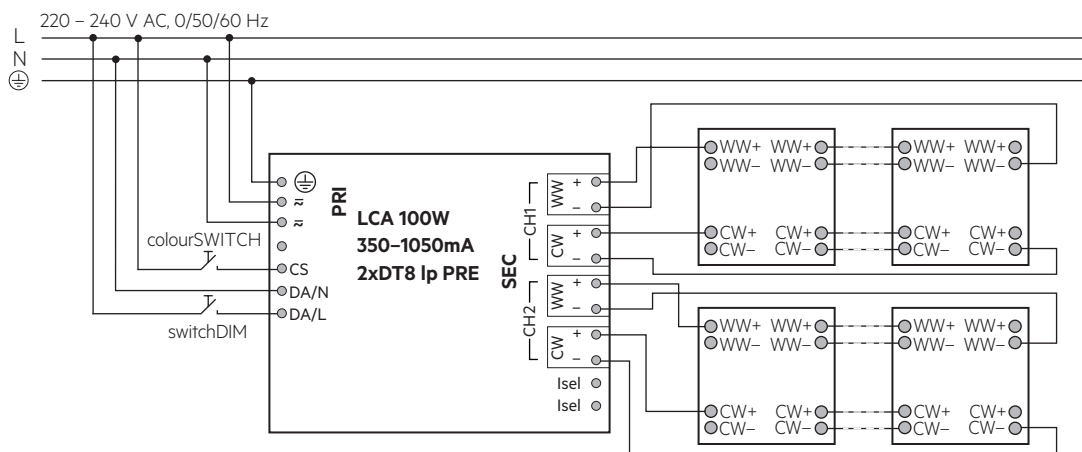

### Wiring diagram for DALI for LLE premium

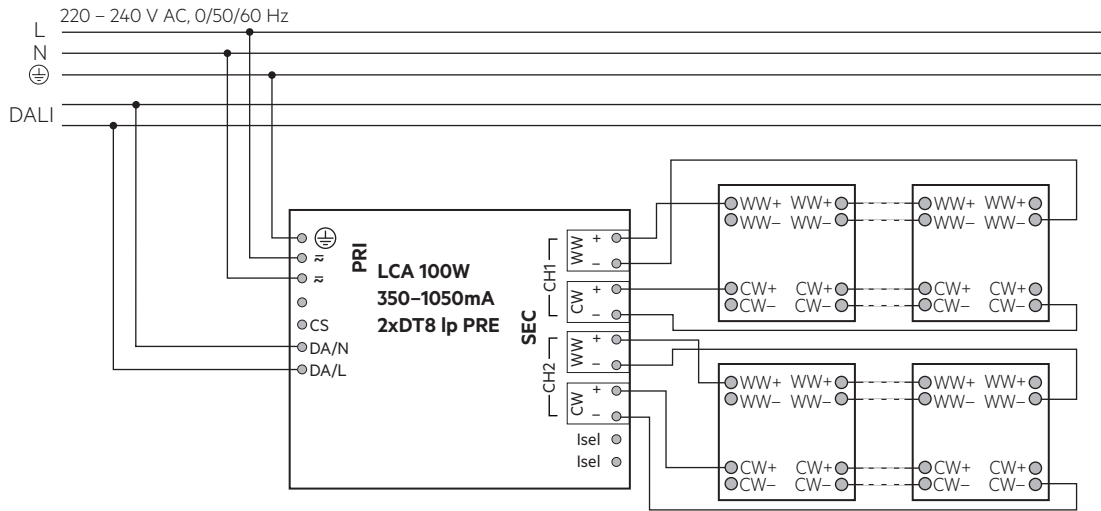

### Wiring diagram for emergency

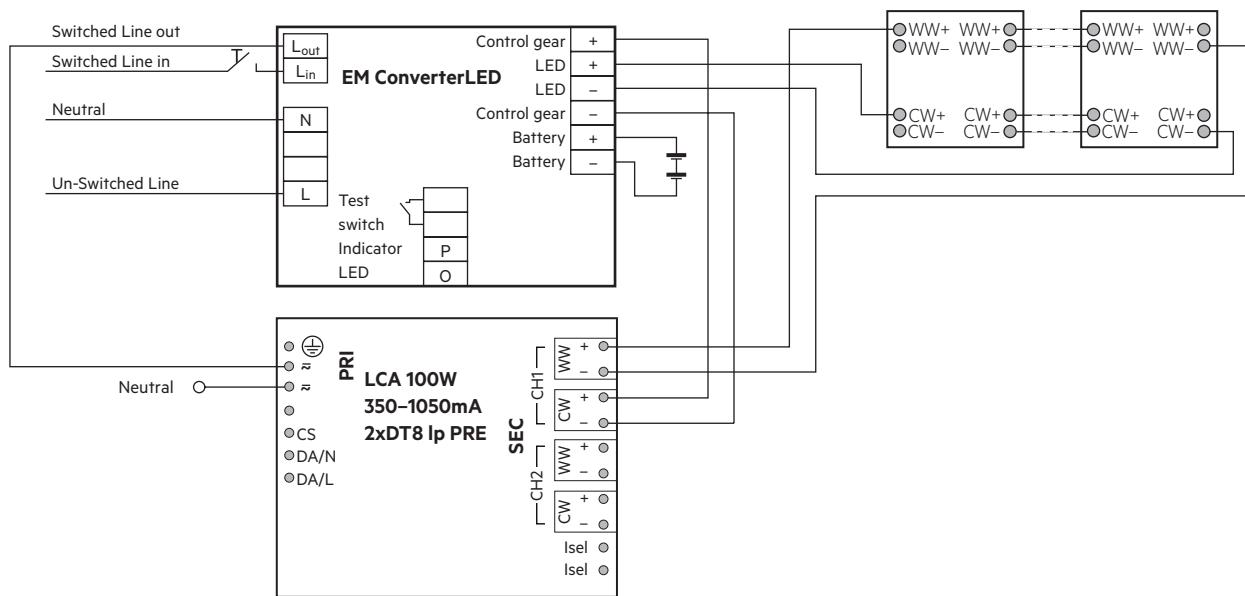

#### Permissible length range of the connected LED modules per LED driver

LED driver	LED module total length
LCA 50W 350-1050mA DT8 Ip PRE	840 - 1,680 mm
LCA 85W 600-1800mA DT8 Ip PRE	1,680 - 2,240 mm
LCA 100W 350-1050mA 2xDT8 Ip PRE	2 x 840 - 1,680 mm

### 3.3 Wiring type and cross section

For wiring use stranded wire with ferrules or solid wire from 0.2 to 0.75 mm<sup>2</sup>. For the push-wire connection you have to strip the insulation (6–9 mm).

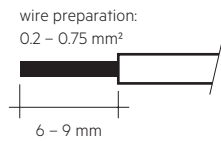

To remove the wires use a suitable tool (e.g. Microcon release pin) or through twist and pull.

### 3.4 Mounting instruction



None of the components of the LLE (substrate, LED, electronic components etc.) may be exposed to tensile or compressive stresses.

Max. torque for fixing: 0.5 Nm.

The LED modules are mounted onto a heat sink with min. 3 screws and plastic washers per module or ACL CLIP 4.3mm.



Chemical substance may harm the LED module. Chemical reactions could lead to colour shift, reduced luminous flux or a total failure of the module caused by corrosion of electrical connections.

Materials which are used in LED applications (e.g. sealings, adhesives) must not produce dissolver gas. They must not be condensation curing based, acetate curing based or contain sulfur, chlorine or phthalate.

Avoid corrosive atmosphere during usage and storage.

### 3.5 EOS/ESD safety guidelines



The device / module contains components that are sensitive to electrostatic discharge and may only be installed in the factory and on site if appropriate EOS/ESD protection measures have been taken. No special measures need be taken for devices/modules with enclosed casings (contact with the pc board not possible), just normal installation practice. Please note the requirements set out in the document EOS / ESD guidelines (Guideline\_EOS\_ESD.pdf) at: <http://www.tridonic.com/esd-protection>

## 4. Lifetime

### 4.1 Lifetime, lumen maintenance and failure rate

The light output of an LED module decreases over the lifetime, this is characterized with the L value.

L70 means that the LED module will have 70 % of its initial luminous flux after the stated operating time. This value is always related to the number of operation hours and therefore defines the lifetime of an LED module.

As the L value is a statistical value the lumen maintenance may vary over the delivered LED modules.

The B value defines the amount of modules which are below the specific L value, e.g. L70B10 means 10 % of the LED modules are below 70 % of the initial luminous flux, respectively 90 % will be above 70 % of the initial value. In addition the percentage of failed modules (fatal failure) is characterized by the C value.

The F value is the combination of the B and C value. That means for F degradation and complete failures are considered, e.g. L70F10 means 10 % of the LED modules may fail or be below 70 % of the initial luminous flux.

### 4.2 Lumen maintenance for LLE premium

Lifetime declarations are informative and represent no warranty claim.

#### LLE G2 24x280MM 700LM LV PRE

Forward current	tp temperature	L90 / F10	L90 / F50	L80 / F10	L80 / F50	L70 / F10	L70 / F50
		>50,000 h	>50,000 h	>50,000 h	>50,000 h	>50,000 h	>50,000 h
165 mA	55 °C	>50,000 h	>50,000 h	>50,000 h	>50,000 h	>50,000 h	>50,000 h
	60 °C	>50,000 h	>50,000 h	>50,000 h	>50,000 h	>50,000 h	>50,000 h
	65 °C	>50,000 h	>50,000 h	>50,000 h	>50,000 h	>50,000 h	>50,000 h
	70 °C	>50,000 h	>50,000 h	>50,000 h	>50,000 h	>50,000 h	>50,000 h

## 5. Photometric characteristics

### 5.1 Coordinates and tolerances according to CIE 1931

The specified colour coordinates are integral measured by a current impulse with typical values of module and a duration of 100 ms. The ambient temperature of the measurement is  $t_a = 25^\circ\text{C}$ . The measurement tolerance of the colour coordinates are  $\pm 0.01$ .

Module type	Current impulse
LLE G2 24x280MM 700LM 927-965 LV PRE	65 mA

#### 2,700 K

	x0	y0
Centre	0.4578	0.4101

MacAdam ellipse: 3SDCM

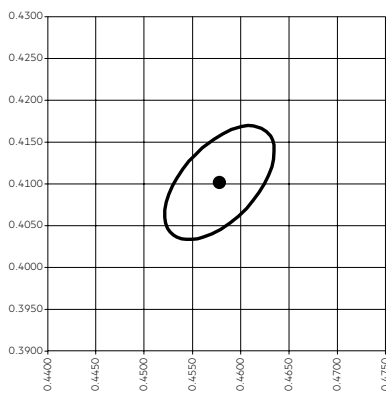

#### 6,500 K

	x0	y0
Centre	0.3123	0.3281

MacAdam ellipse: 3SDCM

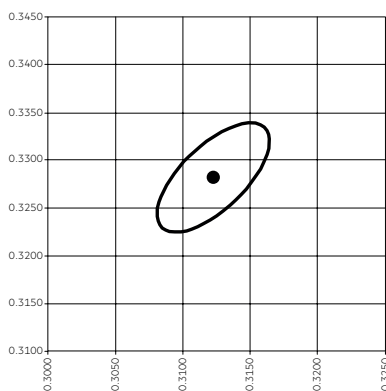

### Colour spectrum at different colour temperatures

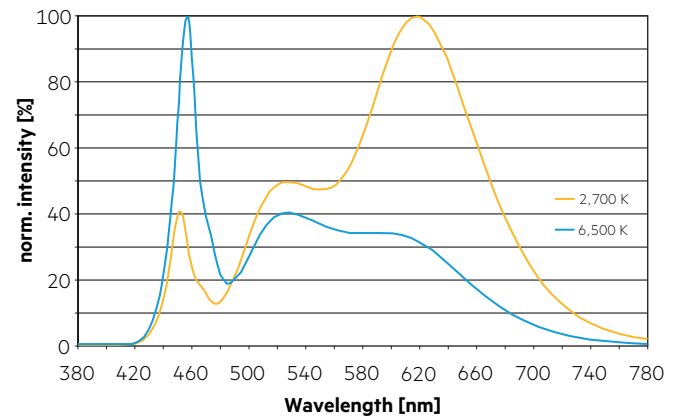

### 5.2 Light distribution

The optical design of the LLE product line ensures optimum homogeneity for the light distribution.



The colour temperature is measured integral over the complete module.

To ensure an ideal mixture of colours and a homogeneous light distribution a suitable optic (e. g. PMMA diffuser) and a sufficient spacing between module and optic (typ. 6 cm) should be used.

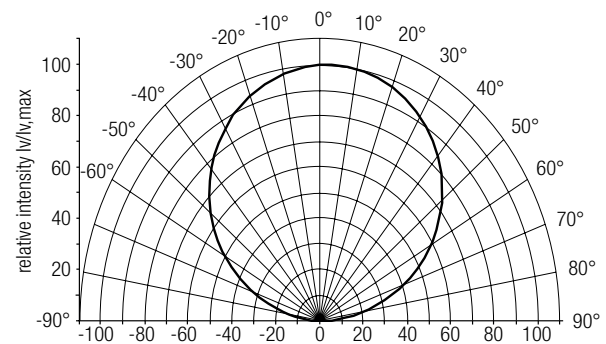

The diagrams are based on statistic values.

### 5.3 Relative luminous flux vs. operating temperature

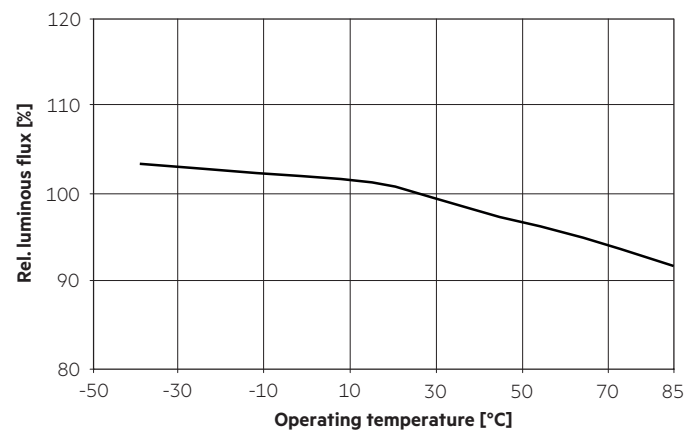

## 6. Miscellaneous

### 6.1 Additional information

Additional technical information Design-in Guide, 3D data, photometric data and Guarantee conditions at [www.tridonic.com](http://www.tridonic.com)

Guarantee conditions at [www.tridonic.com](http://www.tridonic.com) → Services

Lifetime declarations are informative and represent no warranty claim.