

Module LLE 24mm 650lm CRI90 HV ADV5

Modules LLE advanced



LLE 24x140mm 325lm HV ADV5



LLE 24x280mm 650lm HV ADV5



LLE 24x560mm 1300lm HV ADV5

Product description

- _ Ideal for linear and panel lights
- _ 2 terminals for serial wiring
- _ 4,000 K module COI approved acc. to AS/NZS1680.2.5:1997
- _ Perfectly uniform light, even if several LED modules are used together in a line
- _ Push terminals for quick and simple wiring of LED module to LED module
- _ Broad portfolio from extruded lenses and covers available
- _ HE ... High Efficiency, NM ... Nominal Mode, HO ... High Output
- _ Min. order quantity LLE 24x70mm QTY4: 36 pcs. The LLE 24x70mm QTY4 module contains 4 single 24x70mm modules which have to be separated
- _ Long lifetime up to 72,000 hours
- _ 5 years guarantee (conditions at <https://www.tridonic.com/en/int/services/manufacturer-guarantee-conditions>)

Optical properties

- _ Colour temperatures 2,700, 3,000, 3,500 and 4,000 K
- _ Useful luminous flux 1,221 lm at Irated and tp = 25 °C
- _ Efficacy of the LED module 166 lm/W at Irated and tp = 25 °C
- _ High colour rendering index CRI > 90
- _ High colour consistency (MacAdam 3) ①
- _ Small luminous flux tolerances

Mechanical properties

- _ Module dimension 24 x 70 mm, 24 x 140 mm, 24 x 280 mm and 24 x 560 mm (ZHAGA compliant)
- _ Simple installation via clips or screws

System solution

- _ Combine Tridonic's LED modules and dimmable drivers to achieve an outstanding system efficacy (configuration possible via <https://setbuilder.tridonic.com/>)

① Integral measurement over the complete module.

Website

<http://www.tridonic.com/28003964>

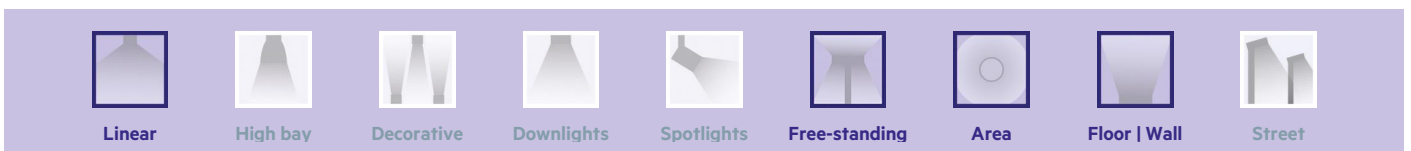

Module LLE 24mm 650lm CRI90 HV ADV5

Modules LLE advanced

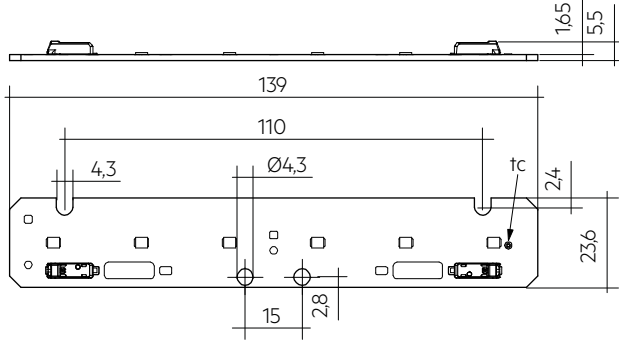

LLE 24x140mm 325lm HV ADV5

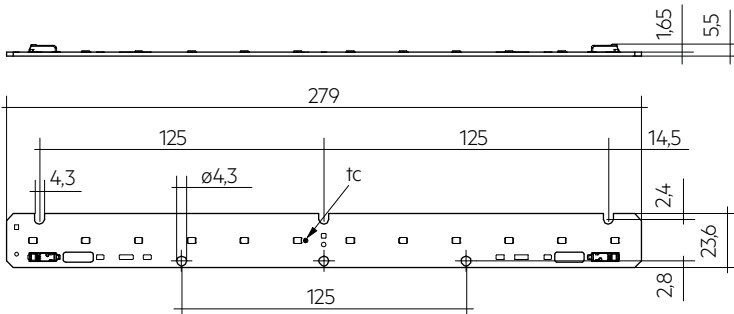

LLE 24x280mm 650lm HV ADV5

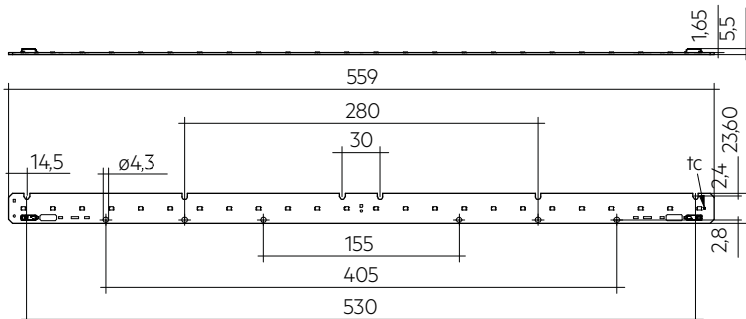

LLE 24x560mm 1300lm HV ADV5

Ordering data

Type	Article number	Colour temperature	Packaging, carton	Weight per pc.
LLE 24x70mm 160lm 930 HV ADV5 QTY4	28003964	3,000 K	108 pc(s).	0.022 kg
LLE 24x70mm 160lm 940 HV ADV5 QTY4	28003966	4,000 K	108 pc(s).	0.022 kg
LLE 24x140mm 325lm 927 HV ADV5	28003027	2,700 K	108 pc(s).	0.011 kg
LLE 24x140mm 325lm 930 HV ADV5	28003028	3,000 K	108 pc(s).	0.011 kg
LLE 24x140mm 325lm 935 HV ADV5	28003319	3,500 K	108 pc(s).	0.011 kg
LLE 24x140mm 325lm 940 HV ADV5	28003029	4,000 K	108 pc(s).	0.011 kg
LLE 24x280mm 650lm 927 HV ADV5	28003030	2,700 K	108 pc(s).	0.021 kg
LLE 24x280mm 650lm 930 HV ADV5	28003031	3,000 K	108 pc(s).	0.021 kg
LLE 24x280mm 650lm 935 HV ADV5	28003320	3,500 K	108 pc(s).	0.021 kg
LLE 24x280mm 650lm 940 HV ADV5	28003032	4,000 K	108 pc(s).	0.021 kg
LLE 24x560mm 1300lm 927 HV ADV5	28003033	2,700 K	108 pc(s).	0.041 kg
LLE 24x560mm 1300lm 930 HV ADV5	28003034	3,000 K	108 pc(s).	0.041 kg
LLE 24x560mm 1300lm 935 HV ADV5	28003402	3,500 K	108 pc(s).	0.041 kg
LLE 24x560mm 1300lm 940 HV ADV5	28003035	4,000 K	108 pc(s).	0.041 kg

Technical data

Beam characteristic	120°
Ambient temperature ta	-40 ... +65 °C
tp rated	50 °C
tc	85 °C
Irated	300 mA
I _{max}	540 mA
Max. permissible LF current ripple	595 mA
Max. permissible peak current	900 mA / max. 10 ms
Max. working voltage for insulation [®]	440 V
Insulation test voltage	1.88 kV
CTI of the printed circuit board	≥ 600
Colour tolerance	3 SDCM
ESD classification	Severity level 4
Risk group (IEC 62471)	RG0
Classification acc. to IEC 62031	Built-in
Type of protection	IP00
Lumen maintenance L70B50	72,000 h
Guarantee (conditions at www.tridonic.com)	5 Year(s)

Approval marks**Standards**

IEC 62031, IEC 62471, IEC 61000-4-2, IEC 62778, IEC 61547, UL 8750

Specific technical data

Type	Article number	Photometric code	Useful luminous flux at tp = 25 °C ^②	Expected luminous flux at tp rated ^③	Typ. forward current	Min. forward voltage at tp rated ^④	Max. forward voltage at tp = 25 °C ^⑤	Power consumption Pon at tp = 25 °C ^⑥	Efficacy of the module at tp = 25 °C	Expected efficacy of the module at tp rated	Colour rendering index CRI
Operating mode HE at 200 mA											
LLE 24x70mm 160lm 930 HV ADV5 QTY4	28003964	930/359	-	83 lm	200 mA	2.6 V	2.8 V	-	-	160 lm/W	>>90
LLE 24x70mm 160lm 940 HV ADV5 QTY4	28003966	940/359	-	89 lm	200 mA	2.6 V	2.8 V	-	-	168 lm/W	>>90
LLE 24x140mm 325lm 927 HV ADV5	28003027	927/359	-	165 lm	200 mA	5.2 V	5.6 V	-	-	151 lm/W	>>90
LLE 24x140mm 325lm 930 HV ADV5	28003028	930/359	-	171 lm	200 mA	5.2 V	5.6 V	-	-	159 lm/W	>>90
LLE 24x140mm 325lm 935 HV ADV5	28003319	935/359	-	173 lm	200 mA	5.2 V	5.6 V	-	-	160 lm/W	>>90
LLE 24x140mm 325lm 940 HV ADV5	28003029	940/359	-	182 lm	200 mA	5.2 V	5.6 V	-	-	165 lm/W	>>90
LLE 24x280mm 650lm 927 HV ADV5	28003030	927/359	-	331 lm	200 mA	10.3 V	11.2 V	-	-	153 lm/W	>>90
LLE 24x280mm 650lm 930 HV ADV5	28003031	930/359	-	341 lm	200 mA	10.3 V	11.2 V	-	-	161 lm/W	>>90
LLE 24x280mm 650lm 935 HV ADV5	28003320	935/359	-	355 lm	200 mA	10.3 V	11.2 V	-	-	165 lm/W	>>90
LLE 24x280mm 650lm 940 HV ADV5	28003032	940/359	-	354 lm	200 mA	10.3 V	11.2 V	-	-	167 lm/W	>>90
LLE 24x560mm 1300lm 927 HV ADV5	28003033	927/359	-	666 lm	200 mA	20.7 V	22.4 V	-	-	152 lm/W	>>90
LLE 24x560mm 1300lm 930 HV ADV5	28003034	930/359	-	687 lm	200 mA	20.7 V	22.4 V	-	-	158 lm/W	>>90
LLE 24x560mm 1300lm 935 HV ADV5	28003402	935/359	-	709 lm	200 mA	20.7 V	22.4 V	-	-	163 lm/W	>>90
LLE 24x560mm 1300lm 940 HV ADV5	28003035	940/359	-	714 lm	200 mA	20.7 V	22.4 V	-	-	165 lm/W	>>90
Operating mode NM at 300 mA											
LLE 24x70mm 160lm 930 HV ADV5 QTY4	28003964	930/359	127 lm	122 lm	300 mA	2.6 V	2.9 V	0.83 W	153 lm/W	150 lm/W	>>90
LLE 24x70mm 160lm 940 HV ADV5 QTY4	28003966	940/359	134 lm	129 lm	300 mA	2.6 V	2.9 V	0.83 W	161 lm/W	158 lm/W	>>90
LLE 24x140mm 325lm 927 HV ADV5	28003027	927/359	242 lm	237 lm	300 mA	5.3 V	5.7 V	1.67 W	145 lm/W	142 lm/W	>>90
LLE 24x140mm 325lm 930 HV ADV5	28003028	930/359	254 lm	249 lm	300 mA	5.3 V	5.7 V	1.67 W	152 lm/W	149 lm/W	>>90
LLE 24x140mm 325lm 935 HV ADV5	28003319	935/359	257 lm	252 lm	300 mA	5.3 V	5.7 V	1.67 W	154 lm/W	150 lm/W	>>90
LLE 24x140mm 325lm 940 HV ADV5	28003029	940/359	265 lm	260 lm	300 mA	5.3 V	5.7 V	1.67 W	159 lm/W	156 lm/W	>>90
LLE 24x280mm 650lm 927 HV ADV5	28003030	927/359	487 lm	477 lm	300 mA	10.5 V	11.4 V	3.30 W	148 lm/W	145 lm/W	>>90
LLE 24x280mm 650lm 930 HV ADV5	28003031	930/359	507 lm	492 lm	300 mA	10.5 V	11.4 V	3.30 W	154 lm/W	151 lm/W	>>90
LLE 24x280mm 650lm 935 HV ADV5	28003320	935/359	525 lm	510 lm	300 mA	10.5 V	11.4 V	3.30 W	159 lm/W	155 lm/W	>>90
LLE 24x280mm 650lm 940 HV ADV5	28003032	940/359	529 lm	514 lm	300 mA	10.5 V	11.4 V	3.30 W	160 lm/W	157 lm/W	>>90
LLE 24x560mm 1300lm 927 HV ADV5	28003033	927/359	979 lm	955 lm	300 mA	21.1 V	22.8 V	6.70 W	146 lm/W	143 lm/W	>>90
LLE 24x560mm 1300lm 930 HV ADV5	28003034	930/359	1,014 lm	985 lm	300 mA	21.1 V	22.8 V	6.70 W	151 lm/W	148 lm/W	>>90
LLE 24x560mm 1300lm 935 HV ADV5	28003402	935/359	1,049 lm	1,019 lm	300 mA	21.1 V	22.8 V	6.70 W	157 lm/W	153 lm/W	>>90
LLE 24x560mm 1300lm 940 HV ADV5	28003035	940/359	1,059 lm	1,030 lm	300 mA	21.1 V	22.8 V	6.70 W	158 lm/W	155 lm/W	>>90
Operating mode HO at 500 mA											
LLE 24x70mm 160lm 930 HV ADV5 QTY4	28003964	930/359	-	200 lm	500 mA	2.7 V	2.9 V	-	-	141 lm/W	>>90
LLE 24x70mm 160lm 940 HV ADV5 QTY4	28003966	940/359	-	213 lm	500 mA	2.7 V	2.9 V	-	-	149 lm/W	>>90
LLE 24x140mm 325lm 927 HV ADV5	28003027	927/359	-	382 lm	500 mA	5.5 V	5.9 V	-	-	132 lm/W	>>90
LLE 24x140mm 325lm 930 HV ADV5	28003028	930/359	-	401 lm	500 mA	5.5 V	5.9 V	-	-	140 lm/W	>>90
LLE 24x140mm 325lm 935 HV ADV5	28003319	935/359	-	405 lm	500 mA	5.5 V	5.9 V	-	-	141 lm/W	>>90
LLE 24x140mm 325lm 940 HV ADV5	28003029	940/359	-	417 lm	500 mA	5.5 V	5.9 V	-	-	146 lm/W	>>90
LLE 24x280mm 650lm 927 HV ADV5	28003030	927/359	-	765 lm	500 mA	10.9 V	11.8 V	-	-	135 lm/W	>>90
LLE 24x280mm 650lm 930 HV ADV5	28003031	930/359	-	795 lm	500 mA	10.9 V	11.8 V	-	-	142 lm/W	>>90
LLE 24x280mm 650lm 935 HV ADV5	28003320	935/359	-	825 lm	500 mA	10.9 V	11.8 V	-	-	146 lm/W	>>90
LLE 24x280mm 650lm 940 HV ADV5	28003032	940/359	-	825 lm	500 mA	10.9 V	11.8 V	-	-	148 lm/W	>>90
LLE 24x560mm 1300lm 927 HV ADV5	28003033	927/359	-	1,547 lm	500 mA	21.8 V	23.5 V	-	-	134 lm/W	>>90
LLE 24x560mm 1300lm 930 HV ADV5	28003034	930/359	-	1,589 lm	500 mA	21.8 V	23.5 V	-	-	140 lm/W	>>90
LLE 24x560mm 1300lm 935 HV ADV5	28003402	935/359	-	1,648 lm	500 mA	21.8 V	23.5 V	-	-	144 lm/W	>>90
LLE 24x560mm 1300lm 940 HV ADV5	28003035	940/359	-	1,652 lm	500 mA	21.8 V	23.5 V	-	-	145 lm/W	>>90

② If mounted with M4 screws and plastic washers.

③ Tolerance of useful light flux - 0 % / + 15 %. Measurement uncertainty ± 10 %.

④ Tolerance of expected light flux - 0 % / + 15 %. Measurement uncertainty ± 10 %. Based on calculation.

⑤ Measurement tolerance forward voltage: ±0.1 V.

⑥ Tolerance of power consumption Pon ± 10 %. Measurement uncertainty ± 5 %.

LINEAR COVER LLE

Accessory

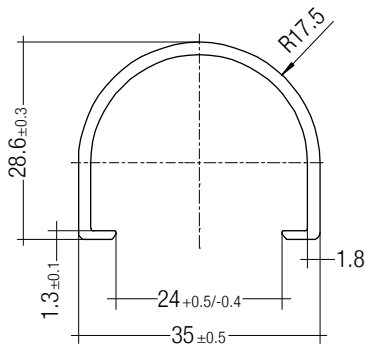

Product description

- _ LINEAR COVER for LLE
- _ Protection against direct touch for non-SELV applications (recommendation LLE 20: use all fixing points and screwed Endcap, recommendation LLE 24: use all fixing points)
- _ Fast snap on mounting on to LLE 20: with M4 screws and plastic washers, to LLE 24: with clips or plastic washers
- _ High transmission: transparent, semi-transparent and diffuse
- _ Material: PMMA
- _ Tolerances: ± 1 mm for 597 mm length (ends finished), + 10 mm from length 1,150 mm (ends raw)

Website

<http://www.tridonic.com/28000338>



Ordering data

Type	Article number	Colour	Length L	Efficiency	Packaging, carton	Weight per pc.
LINEAR COVER SY Transparent 1600mm	28000338	Transparent	1,600 mm	94 %	12 pc(s).	0.272 kg
LINEAR COVER SY Frosted 1800mm	28000437	Semi-transparent	1,800 mm	87 %	12 pc(s).	0.308 kg
LINEAR COVER SY Frosted 1600mm	28000339	Semi-transparent	1,600 mm	87 %	12 pc(s).	0.272 kg
LINEAR COVER SY Frosted 1500mm	28000435	Semi-transparent	1,500 mm	87 %	12 pc(s).	0.244 kg
LINEAR COVER SY Frosted 1200mm	28000422	Semi-transparent	1,200 mm	87 %	12 pc(s).	0.205 kg
LINEAR COVER SY Frosted 597mm	28000340	Semi-transparent	597 mm	87 %	12 pc(s).	0.102 kg
LINEAR COVER SY Diffuse 1800mm	28000438	Diffuse	1,800 mm	76 %	12 pc(s).	0.308 kg
LINEAR COVER SY Diffuse 1600mm	28000341	Diffuse	1,600 mm	76 %	12 pc(s).	0.272 kg
LINEAR COVER SY Diffuse 1500mm	28000436	Diffuse	1,500 mm	76 %	12 pc(s).	0.257 kg
LINEAR COVER SY Diffuse 1200mm	28000434	Diffuse	1,200 mm	76 %	12 pc(s).	0.205 kg
LINEAR COVER SY Diffuse 597mm	28000342	Diffuse	597 mm	76 %	12 pc(s).	0.102 kg

ACL ENDCAP LLE

Accessory

**Product description**

- _ ENDCAP for LLE
- _ PUSH-FIX: Fast snap on mounting (sheet thickness 0.5 – 1.0 mm), for drilling hole 4 mm
- _ SCREW-FIX: Screw mounting with EJOT Delta PT WN 5451 30x8 (not included), tightening torque 0.7 Nm
- _ Clip made of polycarbonate

Website

<http://www.tridonic.com/28001037>

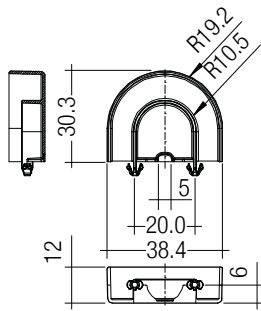
**Ordering data**

Type	Article number	Colour	Packaging, carton	Weight per pc.
ACL ENDCAP LLE24 PUSH-FIX	28001037	White	480 pc(s).	0.003 kg
ACL ENDCAP LLE24 SCREW-FIX	28002315	White	480 pc(s).	0.003 kg

ACL LINEAR LENS 24mm

Accessory

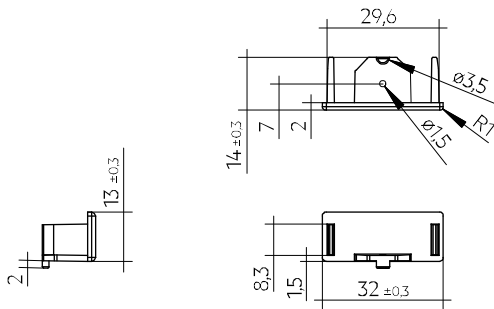
**Product description LINEAR LENS**

- _ Linear lens for LLE 20 / 24
- _ Available with different beam characteristics
- _ Protection against direct touch for non-SELV applications (recommendation: use all fixing points)
- _ Fast snap on mounting on to LLE 20: with M4 screws and plastic washers, to LLE 24: with clips or plastic washers
- _ Recommendation: Fastening with screws and plastic washers, see 2.3 Heat sink specifications in data sheet
- _ Material: PMMA
- _ Available lengths: 1,200, 1,500 and 1,800 mm, Tolerance: + 10 mm (ends raw)
- _ Max. permissible temperature 80 °C
- _ Photometric data available on website

Product description Endcap

- _ ENDCAP for LINEAR LENS 24mm INTENSE, ASY and DASY
- _ Mounting by clipping in and screwing from below using screw EJOT Delta PT WN 5451 20x4, tightening torque 0.7 Nm
- _ Made of Polyamide UL94 V0

Website

<http://www.tridonic.com/28001428>

**Ordering data**

Type	Article number	Length L	Beam characteristic	Efficiency	Packaging, carton	Weight per pc.
ACL LINEAR LENS 24x1200mm 60°	28001428	1,200 mm	60°	97 %	21 pc(s).	0.196 kg
ACL LINEAR LENS 24x1200mm 90°	28001429	1,200 mm	90°	97 %	21 pc(s).	0.165 kg
ACL LINEAR LENS 24x1500mm 60°	28000953	1,500 mm	60°	97 %	21 pc(s).	0.261 kg
ACL LINEAR LENS 24x1500mm 90°	28000955	1,500 mm	90°	97 %	21 pc(s).	0.221 kg
ACL LINEAR LENS 24x1200mm INTENSE	28002024	1,200 mm	40°	95 %	18 pc(s).	0.261 kg
ACL LINEAR LENS 24x1500mm INTENSE	28002025	1,500 mm	40°	95 %	18 pc(s).	0.326 kg
ACL LINEAR LENS 24x1800mm INTENSE	28002026	1,800 mm	40°	95 %	18 pc(s).	0.392 kg
ACL LINEAR LENS 24x1200mm BATWING	28002027	1,200 mm	batwing	95 %	18 pc(s).	0.275 kg
ACL LINEAR LENS 24x1500mm BATWING	28002028	1,500 mm	batwing	95 %	18 pc(s).	0.344 kg
ACL LINEAR LENS 24x1800mm BATWING	28002029	1,800 mm	batwing	95 %	18 pc(s).	0.412 kg
ACL LINEAR LENS 24x1200mm ASY	28002030	1,200 mm	asymmetric	95 %	18 pc(s).	0.250 kg
ACL LINEAR LENS 24x1500mm ASY	28002031	1,500 mm	asymmetric	95 %	18 pc(s).	0.312 kg
ACL LINEAR LENS 24x1800mm ASY	28002032	1,800 mm	asymmetric	95 %	18 pc(s).	0.375 kg
ACL LINEAR LENS 24x1200mm DASY	28002033	1,200 mm	double asymmetric	92 %	18 pc(s).	0.249 kg
ACL LINEAR LENS 24x1500mm DASY	28002034	1,500 mm	double asymmetric	92 %	18 pc(s).	0.311 kg
ACL LINEAR LENS 24x1800mm DASY	28002035	1,800 mm	double asymmetric	92 %	18 pc(s).	0.373 kg
ACL Endcap LENS 24mm PSF	28002669	-	-	-	3,600 pc(s).	0.003 kg

ACL CLIP 4.3mm

Accessory

**Product description**

- _ Clip for fixation of LED modules with 4.3 mm holes
- _ Fast snap on mounting (sheet thickness 0.5 – 1.0 mm for PUSH-FIX and 1 – 2 mm for PUSH-FIX Long)
- _ For drilling hole 4 mm
- _ Clip made of polycarbonate
- _ Minimum sales quantity 500 pcs.

Website

<http://www.tridonic.com/28001036>

**Ordering data**

Type	Article number	Colour	Packaging, bag ^①	Weight per pc.
ACL CLIP 4.3mm PUSH-FIX	28001036	White	500 pc(s).	0.001 kg
ACL CLIP 4,3mm PUSH-FIX Long	28002314	Transparent	500 pc(s).	0.001 kg

① Minimum sales quantity 500 pcs.

ACL BRIDGE LLE24/40

Accessory

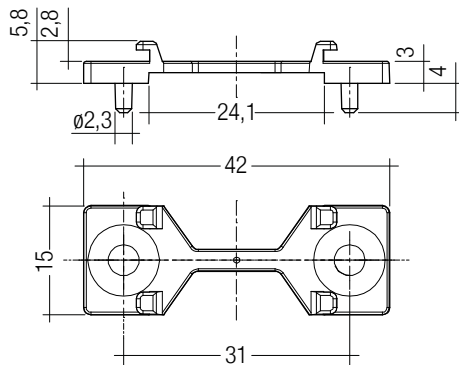
**Product description**

- _ Enables the fixation of 24 mm wide Tridonic LED modules to fixtures made for 40 mm wide modules
- _ Ideal for extruded aluminium gear trays made for 40 mm modules with pre-alignment knobs
- _ Clip-on for LINEAR COVER and LINEAR LENS ^①
- _ For LLE 24 with 280 mm module minimum 2 bridges required
- _ For LLE 24 with 560 mm module minimum 3 bridges required
- _ Fixation via M3 or M4 countersunk screw, max. tightening torque 0.5 Nm
- _ Material: white polycarbonate
- _ Minimum sales quantity 600 pcs.

^① Beam characteristics will change due to the elevated fixation (see photometric files for details).

Website

<http://www.tridonic.com/28001205>

**Ordering data**

Type	Article number	Colour	Packaging, carton	Weight per pc.
ACL BRIDGE LLE24/40 SCREW-FIX	28001205	White	600 pc(s).	0.001 kg

1. Standards

IEC 62031
IEC 62471
IEC 61000-4-2
IEC 62778
IEC 61547
UL 8750

1.1 Photometric code

Key for photometric code, e. g. 830 / 349

1 st digit	2 nd + 3 rd digit	4 th digit	5 th digit	6 th digit		
Code	CRI	Colour temperature in Kelvin x 100	MacAdam initial	MacAdam after 25% of the life-time (max.6000h)		
7	70 – 79				Luminous flux after 25% of the life-time (max.6000h)	
8	80 – 89				Code	Luminous flux
9	≥90				7	≥ 70 %
			8	≥ 80 %		
			9	≥ 90 %		

1.2 Energy classification

Typ	Energieklassifizierung
LLE 24mm HV ADV5	A++

2. Thermal details

2.1 tc point, ambient temperature and life-time

The temperature at tp reference point is crucial for the light output and life-time of a LED product.

For LLE a tp temperature of 50 °C has to be complied in order to achieve an optimum between heat sink requirements, light output and life-time.

Compliance with the maximum permissible reference temperature at the tc point must be checked under operating conditions in a thermally stable state. The maximum value must be determined under worst-case conditions for the relevant application.

The tc and tp temperature of LED modules from Tridonic are measured at the same reference point.

2.2 Storage and humidity

Storage temperature	-30...+80 °C
---------------------	--------------

Operation only in non condensing environment.

Humidity during processing of the module should be between 30 to 70 %.

2.3 Heat sink values

LLE 24x140mm 325lm ADV5

ta	tp	Forward current	R _{th, hs-a}	Cooling area
25 °C	50 °C	300 mA		self cooling
25 °C	50 °C	500 mA	17.2 K/W	39 cm ²
35 °C	50 °C	300 mA	19.5 K/W	35 cm ²
35 °C	50 °C	500 mA	10.3 K/W	65 cm ²
45 °C	50 °C	300 mA	6.3 K/W	105 cm ²
45 °C	50 °C	500 mA	3.4 K/W	194 cm ²

LLE 24x280mm 650lm ADV5

ta	tp	Forward current	R _{th, hs-a}	Cooling area
25 °C	50 °C	300 mA		self cooling
25 °C	50 °C	500 mA	8.61 K/W	77 cm ²
35 °C	50 °C	300 mA	9.50 K/W	70 cm ²
35 °C	50 °C	500 mA	5.17 K/W	129 cm ²
45 °C	50 °C	300 mA	3.16 K/W	211 cm ²
45 °C	50 °C	500 mA	1.72 K/W	388 cm ²

LLE 24x560mm 1300lm ADV5

ta	tp	Forward current	R _{th, hs-a}	Cooling area
25 °C	50 °C	300 mA		self cooling
25 °C	50 °C	500 mA	4.31 K/W	155 cm ²
35 °C	50 °C	300 mA	4.75 K/W	140 cm ²
35 °C	50 °C	500 mA	2.58 K/W	258 cm ²
45 °C	50 °C	300 mA	1.58 K/W	422 cm ²
45 °C	50 °C	500 mA	0.86 K/W	776 cm ²

Notes

The actual cooling surface can differ because of the material, the structural shape, outside influences and the installation situation. Depending on the heat sink a heat conducting paste or heat conducting film might be necessary to keep the specified tp temperature.

3. Installation / wiring

3.1 Electrical supply/choice of LED Driver

LLE modules from Tridonic are not protected against overvoltages, overcurrents, overloads or short-circuit currents. Safe and reliable operation can only be guaranteed in conjunction with a LED Driver which complies with the relevant standards. The use of LED Driver from Tridonic in combination with LLE modules guarantees the necessary protection for safe and reliable operation.

If a LED Driver other than Tridonic is used, it must provide the following protection:

- Short-circuit protection
- Overload protection
- Overtemperature protection



LLE modules must be supplied by a constant current LED Driver. Operation with a constant voltage LED Driver will lead to an irreversible damage of the module.

Wrong polarity can damage the LLE.

The LLE module is designed for serial wiring.

With parallel wiring tolerance-related differences in output are possible (thermal stress of the module) and can cause differences in brightness.

If a wire breaks or a complete module fails then the current passing through the other module increases. This may reduce its life considerably.

Max. 8 pieces 280 mm modules or 4 pieces 560 mm modules may be connected in parallel.

LLE can be operated either from SELV LED Drivers or from LED Drivers with LV output voltage.



LLE are basic insulated up to 440 V (if mounted with M4 screws with head diameter 7 mm in combination with plastic washers) against ground and can be mounted directly on earthed metal parts of the luminaire. If the max. output voltage of the LED Driver (also against earth) is above 440 V, an additional insulation between LED module and heat sink is required (for example by insulated thermal pads) or by a suitable luminaire construction.

At voltages > 60 V an additional protection against direct touch (test finger) to the light emitting side of the module has to be guaranteed.

This is typically achieved by means of a non removable light distributor over the module.

3.2 Wiring

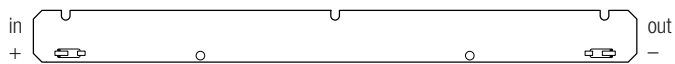

Wiring examples for serial wiring

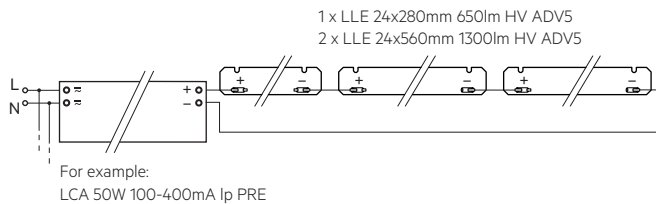
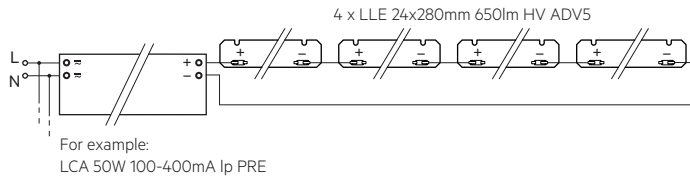

Wiring examples for parallel wiring

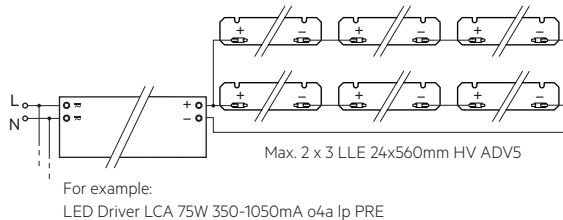

3.3 Wiring type and cross section

The wiring can be in stranded wires or solid with a cross section of 0.2 to 0.75 mm².

For the push-wire connection you have to strip the insulation (8–9 mm).

wire preparation:
0.2 – 0.75 mm²

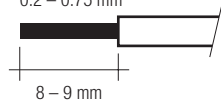

To remove the wires use a suitable tool (e.g. Microcon release pin) or through twist and pull.

3.4 Mounting instruction



None of the components of the LLE (substrate, LED, electronic components etc.) may be exposed to tensile or compressive stresses.

Max. torque for fixing: 0.5 Nm.

The LED modules are mounted onto a heat sink with min. 3 screws per module or ACL CLIP 4.3mm.



Chemical substance may harm the LED module. Chemical reactions could lead to colour shift, reduced luminous flux or a total failure of the module caused by corrosion of electrical connections.

Materials which are used in LED applications (e.g. sealings, adhesives) must not produce dissolver gas. They must not be condensation curing based, acetate curing based or contain sulfur, chlorine or phthalate.

Avoid corrosive atmosphere during usage and storage.

3.5 EOS/ESD safety guidelines



The device / module contains components that are sensitive to electrostatic discharge and may only be installed in the factory and on site if appropriate EOS/ESD protection measures have been taken. No special measures need be taken for devices/modules with enclosed casings (contact with the pc board not possible), just normal installation practice. Please note the requirements set out in the document EOS / ESD guidelines (Guideline_EOS_ESD.pdf) at: <http://www.tridonic.com/esd-protection>

4. Life-time

4.1 Life-time, lumen maintenance and failure rate

The light output of an LED Module decreases over the life-time, this is characterized with the L value.

L70 means that the LED module will give 70 % of its initial luminous flux.

This value is always related to the number of operation hours and therefore defines the life-time of an LED module.

As the L value is a statistical value and the lumen maintenance may vary over the delivered LED modules.

The B value defines the amount of modules which are below the specific L value, e.g. L70B10 means 10 % of the LED modules are below 70 % of the initial luminous flux, respectively 90 % will be above 70 % of the initial value.

In addition the percentage of failed modules (fatal failure) is characterized by the C value.

4.2 Lumen maintenance for LLE 24mm HV ADV5

Forward current	tp						
	tempera- ture	L90 / B10	L90 / B50	L80 / B10	L80 / B50	L70 / B10	L70 / B50
150 mA	40 °C	41k h	51k h	>72k h	>72k h	>72k h	>72k h
	50 °C	38k h	48k h	>72k h	>72k h	>72k h	>72k h
	60 °C	35k h	45k h	71k h	>72k h	>72k h	>72k h
	70 °C	32k h	42k h	65k h	>72k h	>72k h	>72k h
	80 °C	30k h	39k h	60k h	>72k h	>72k h	>72k h
200 mA	40 °C	41k h	51k h	>72k h	>72k h	>72k h	>72k h
	50 °C	37k h	47k h	>72k h	>72k h	>72k h	>72k h
	60 °C	34k h	44k h	70k h	>72k h	>72k h	>72k h
	70 °C	32k h	41k h	64k h	>72k h	>72k h	>72k h
	80 °C	29k h	38k h	59k h	>72k h	>72k h	>72k h
300 mA	40 °C	40k h	50k h	>72k h	>72k h	>72k h	>72k h
	50 °C	37k h	47k h	>72k h	>72k h	>72k h	>72k h
	60 °C	34k h	44k h	69k h	>72k h	>72k h	>72k h
	70 °C	31k h	41k h	63k h	>72k h	>72k h	>72k h
	80 °C	29k h	38k h	58k h	>72k h	>72k h	>72k h
375 mA	40 °C	39k h	49k h	>72k h	>72k h	>72k h	>72k h
	50 °C	36k h	46k h	>72k h	>72k h	>72k h	>72k h
	60 °C	33k h	43k h	68k h	>72k h	>72k h	>72k h
	70 °C	31k h	40k h	62k h	>72k h	>72k h	>72k h
	80 °C	28k h	37k h	57k h	>72k h	>72k h	>72k h
450 mA	40 °C	39k h	49k h	>72k h	>72k h	>72k h	>72k h
	50 °C	36k h	46k h	>72k h	>72k h	>72k h	>72k h
	60 °C	33k h	42k h	67k h	>72k h	>72k h	>72k h
	70 °C	30k h	40k h	61k h	>72k h	>72k h	>72k h
	80 °C	28k h	37k h	56k h	>72k h	>72k h	>72k h
500 mA	40 °C	38k h	48k h	>72k h	>72k h	>72k h	>72k h
	50 °C	35k h	45k h	71k h	>72k h	>72k h	>72k h
	60 °C	32k h	42k h	65k h	>72k h	>72k h	>72k h
	70 °C	30k h	39k h	60k h	>72k h	>72k h	>72k h
	80 °C	27k h	36k h	55k h	>72k h	>72k h	>72k h

LOC10 >72 kh

At tp rated and Irated, based on 10 switching cycles per day.

4.3 Switching capability

100,000 cycles

Tridonic test according to IEC 62717 Cl 10.3.3

30 s on / 30 s off at Imax

5. Electrical values

5.1 Declaration of electrical parameters

Irated ... Nominal operating current the module is designed for.

I_{max} ... Max. permissible continuous operating current incl. The tolerances of the LED driver.

Max. permissible LF current ripple ... Max. output current of the LED driver incl. Tolerances and LF current ripple must not exceed this value.

Max. permissible peak current ... The max. output peak current of the LED driver must not exceed this value.

5.2 Typ. forward voltage vs. forward current

LLE 24x140mm 325lm 9xx HV ADV5

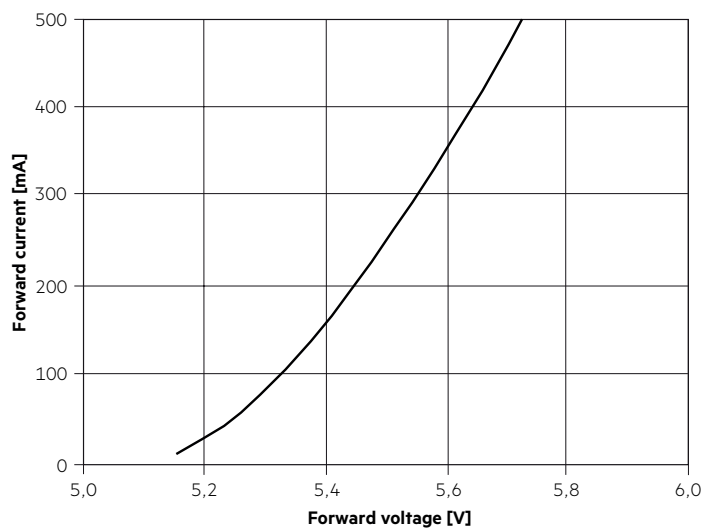

LLE 24x280mm 650lm 9xx HV ADV5

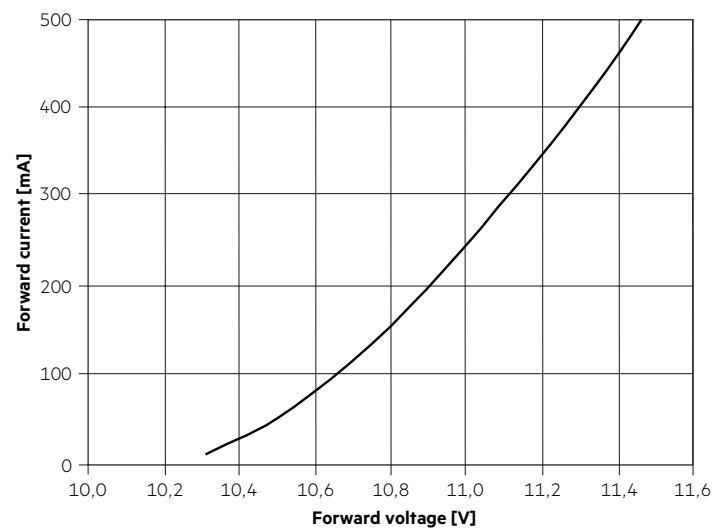

LLE 24x560mm 1300lm 9xx HV ADV5

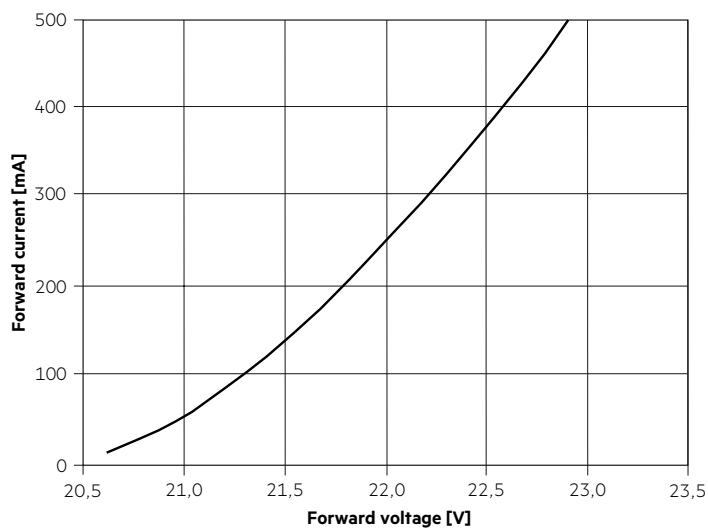

5.3 Forward voltage vs. tc temperature

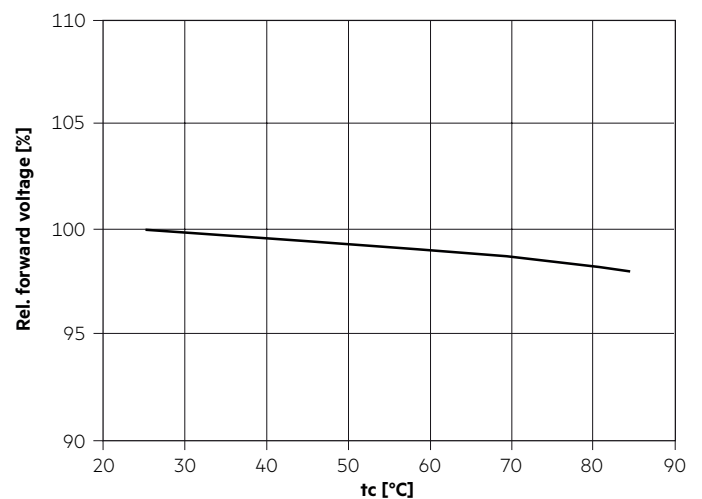

The diagrams are based on statistic values.
The real values can be different.

6. Photometric characteristics

6.1 Coordinates and tolerances according to CIE 1931

The specified colour coordinates are integral measured by current impulse of 195 mA and a duration of 100 ms.
 The ambient temperature of the measurement is $t_a = 25^\circ\text{C}$.
 The measurement tolerance of the colour coordinates are ± 0.01 .

2,700 K

	x0	y0
Centre	0.4578	0.4101

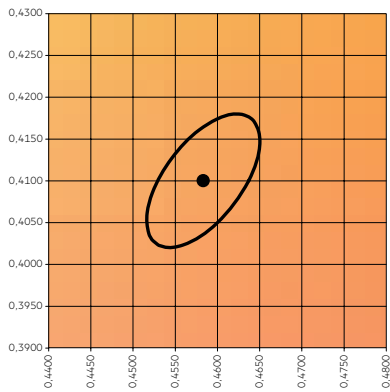

— MacAdam Ellipse: 3SDCM

TM30		CRI	
Rf	Rg	Ra	R9
91	99	93	57

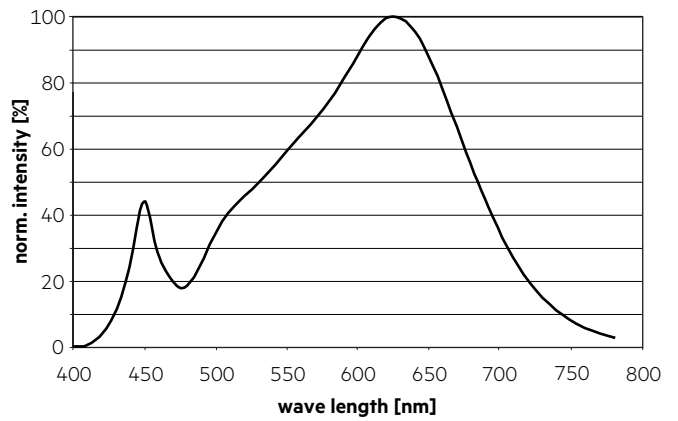

Colour vector graphic

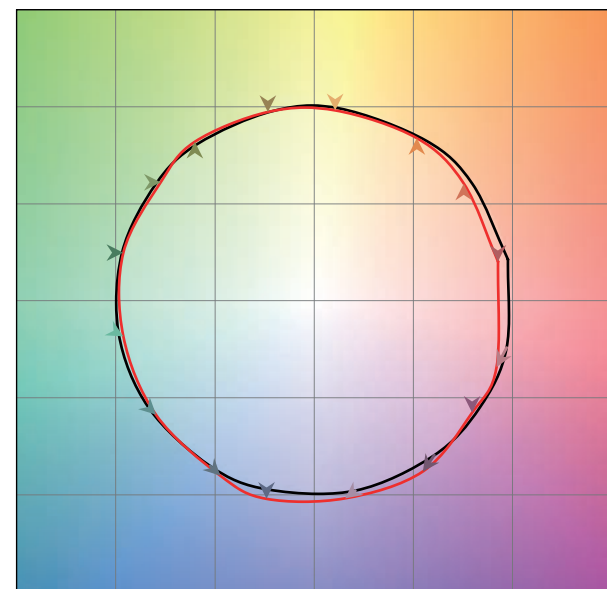

— Reference source
 — Test source

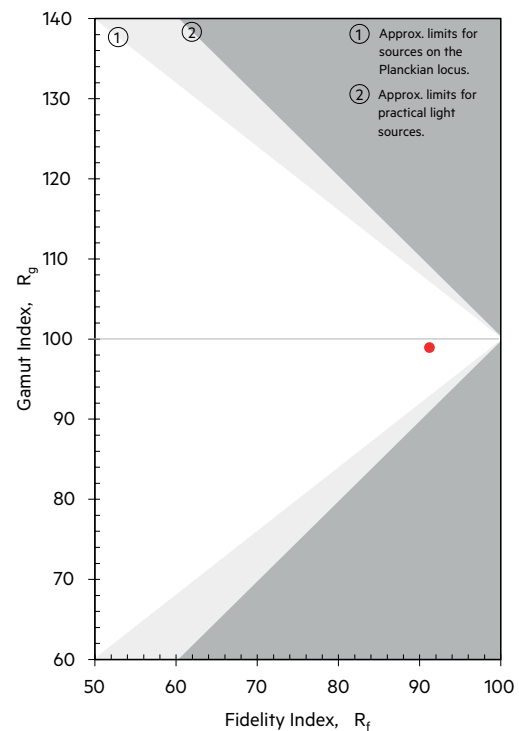

3,000 K

	x0	y0
Centre	0.4338	0.4030

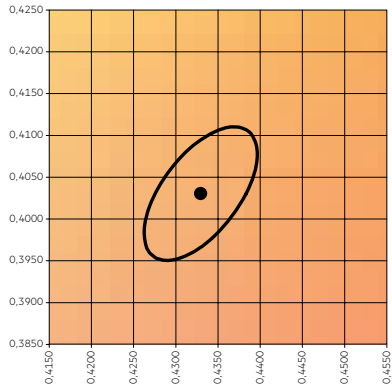

— MacAdam Ellipse: 3SDCM

TM30		CRI	
Rf	Rg	Ra	R9
90	98	92	57

Colour vector graphic

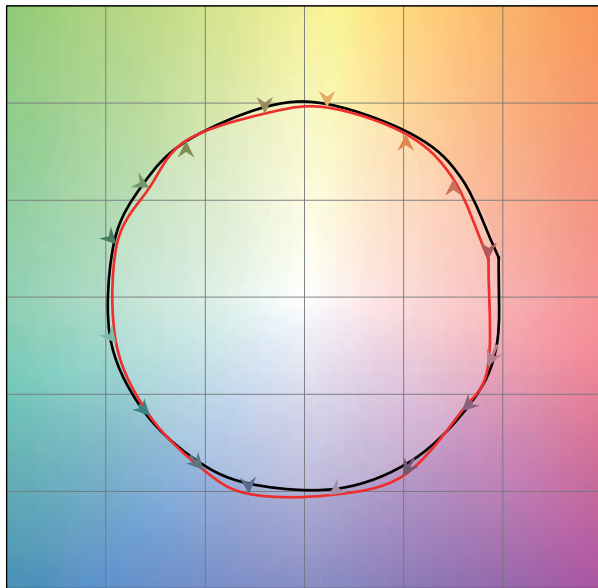

— Reference source
— Test source

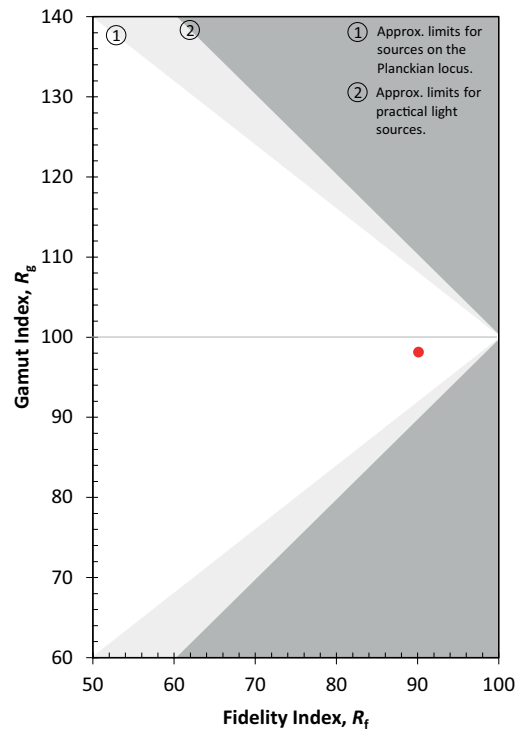
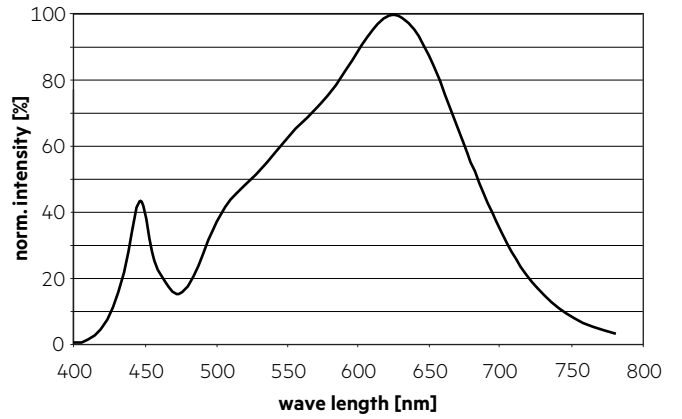

4,000 K

	x0	y0
Center	0.3818	0.3797

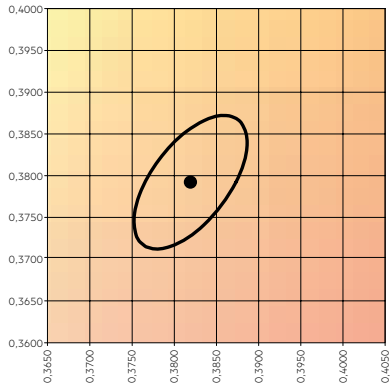

— MacAdam Ellipse: 3SDCM

TM30		CRI	
Rf	Rg	Ra	R9
89	99	91	54

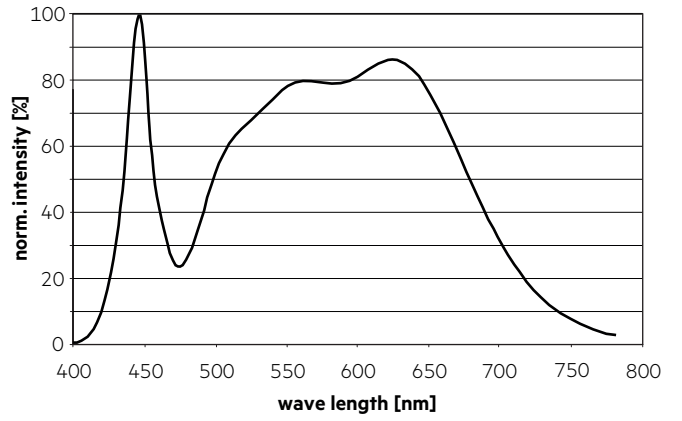

Colour vector graphic

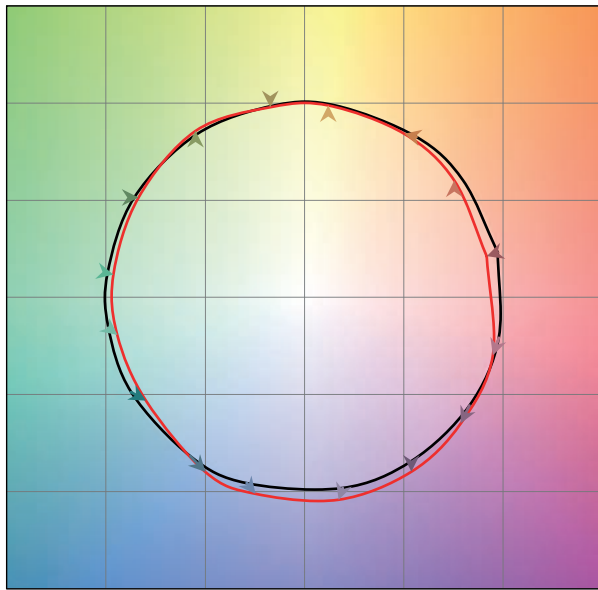

— Reference source
— Test source

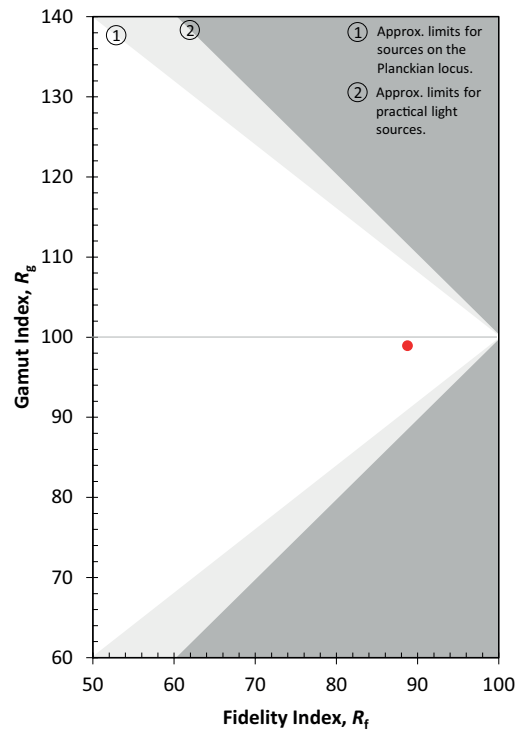

6.2 Light distribution

The optical design of the LLE product line ensures optimum homogeneity for the light distribution.

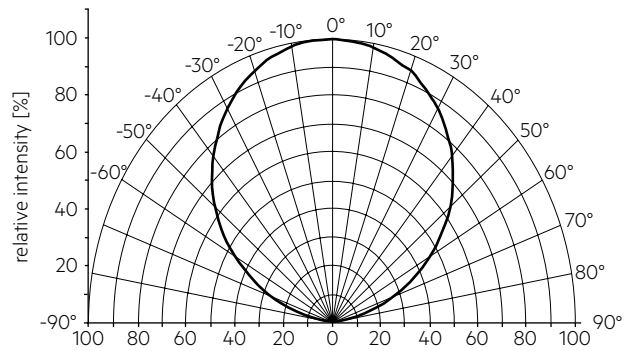

The colour temperature is measured integral over the complete module. The single LED light points can have deviations in the colour coordinates within MacAdam 5. To ensure an ideal mixture of colours and a homogeneous light distribution a suitable optic (e. g. PMMA diffuser) and a sufficient spacing between module and optic (typ. 4 cm) should be used.

6.3 Relative luminous flux vs. tc temperature

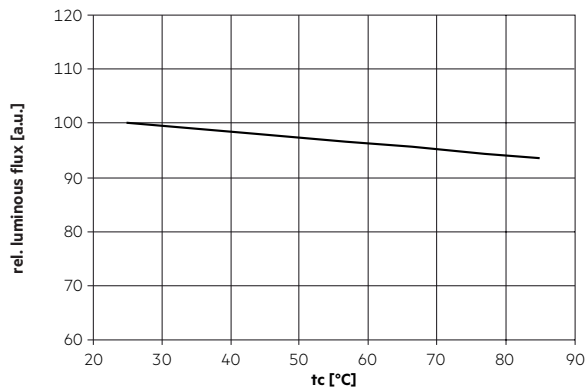

6.4 Relative luminous flux vs. operating current

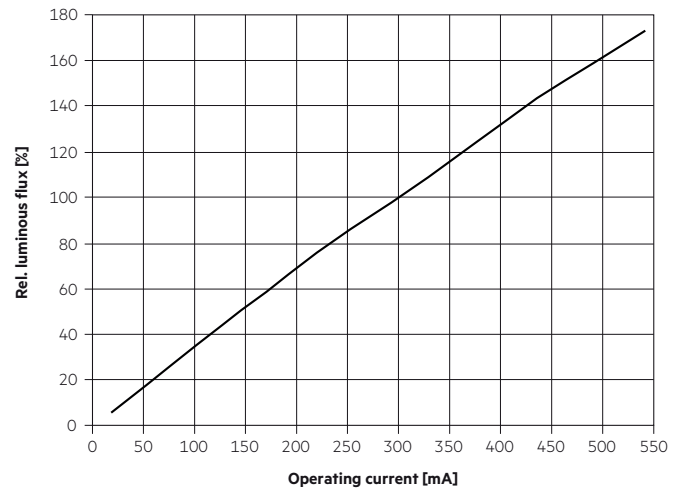

The diagrams are based on statistic values. The real values can be different.

7. Miscellaneous

7.1 Additional information

Additional technical information at www.tridonic.com → Technical Data

Guarantee conditions at www.tridonic.com → Services

Life-time declarations are informative and represent no warranty claim.