

**Module LLE 24mm 1250lm CRI90 HV ADV5**

Modules LLE advanced



LLE 24x140mm 650lm HV ADV5



LLE 24x280mm 1250lm HV ADV5



LLE 24x560mm 2400lm HV ADV5

**Product description**

- \_ Ideal for linear and panel lights
- \_ 2 terminals for serial wiring
- \_ 4,000 K module COI approved acc. to AS/NZS1680.2.5:1997
- \_ Perfectly uniform light, even if several LED modules are used together in a line
- \_ Push terminals for quick and simple wiring of LED module to LED module
- \_ Broad portfolio from extruded lenses and covers available
- \_ HE ... High Efficiency, NM ... Nominal Mode, HO ... High Output
- \_ Min. order quantity LLE 24x70mm QTY4: 36 pcs. The LLE 24x70mm QTY4 module contains 4 single 24x70mm modules which have to be separated
- \_ Long lifetime up to 72,000 hours
- \_ 5 years guarantee (conditions at <https://www.tridonic.com/manufacturer-guarantee-conditions>)

**Optical properties**

- \_ Colour temperatures 2,700, 3,000, 3,500 and 4,000 K
- \_ Useful luminous flux 2,118 lm at Irated and tp = 25 °C
- \_ Efficacy of the LED module 160 lm/W at Irated and tp = 25 °C
- \_ High colour rendering index CRI > 90
- \_ High colour consistency (MacAdam 3) ①
- \_ Small luminous flux tolerances

**Mechanical properties**

- \_ Module dimension 24 x 70 mm, 24 x 140 mm, 24 x 280 mm and 24 x 560 mm (ZHAGA compliant)
- \_ Simple installation via clips or screws

**System solution**

- \_ Combine Tridonic's LED modules and dimmable drivers to achieve an outstanding system efficacy (configuration possible via <https://setbuilder.tridonic.com/>)

① Integral measurement over the complete module.

**Website**

<http://www.tridonic.com/28003972>

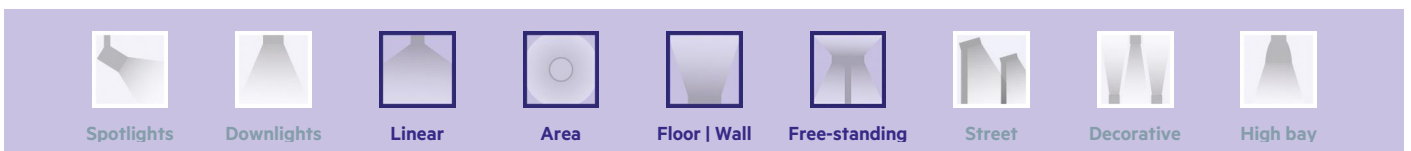
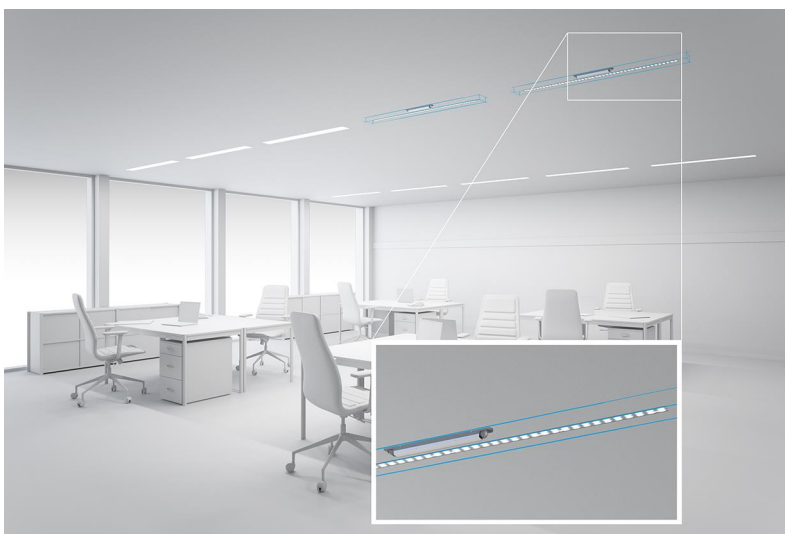

**Module LLE 24mm 1250lm CRI90 HV ADV5**

Modules LLE advanced

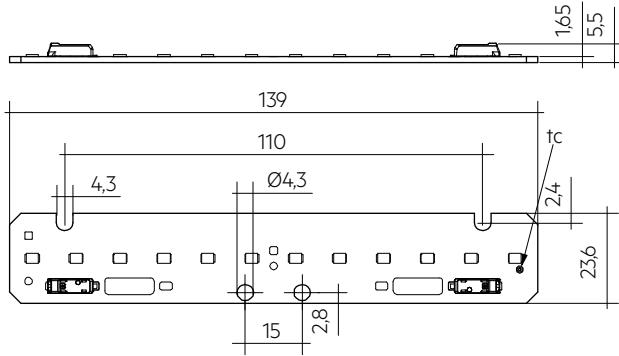

LLE 24x140mm 650lm HV ADV5

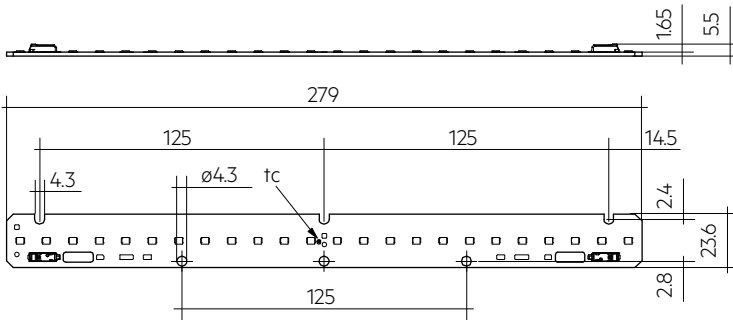

LLE 24x280mm 1250lm HV ADV5

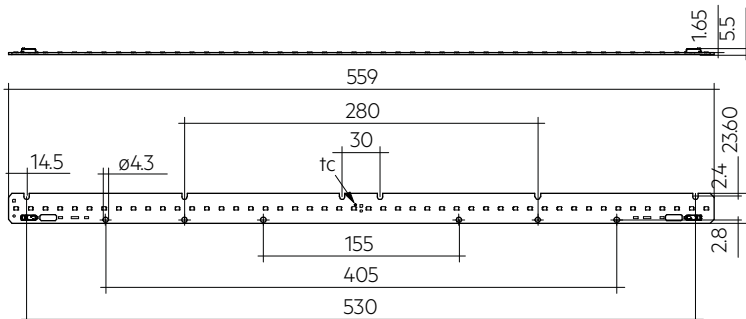

LLE 24x560mm 2400lm HV ADV5

**Ordering data**

Type	Article number	Colour temperature	Packaging, carton	Weight per pc.
LLE 24x70mm 325lm 930 HV ADV5 QTY4	28003972	3,000 K	108 pc(s).	0.022 kg
LLE 24x70mm 325lm 940 HV ADV5 QTY4	28003974	4,000 K	108 pc(s).	0.022 kg
LLE 24x140mm 650lm 927 HV ADV5	89603226	2,700 K	108 pc(s).	0.011 kg
LLE 24x140mm 650lm 930 HV ADV5	89603227	3,000 K	108 pc(s).	0.011 kg
LLE 24x140mm 650lm 935 HV ADV5	28003411	3,500 K	108 pc(s).	0.011 kg
LLE 24x140mm 650lm 940 HV ADV5	89603228	4,000 K	108 pc(s).	0.011 kg
LLE 24x280mm 1250lm 927 HV ADV5	89603229	2,700 K	108 pc(s).	0.023 kg
LLE 24x280mm 1250lm 930 HV ADV5	89603230	3,000 K	108 pc(s).	0.023 kg
LLE 24x280mm 1250lm 935 HV ADV5	28003412	3,500 K	108 pc(s).	0.023 kg
LLE 24x280mm 1250lm 940 HV ADV5	89603231	4,000 K	108 pc(s).	0.023 kg
LLE 24x560mm 2400lm 930 HV ADV5	89603233	3,000 K	108 pc(s).	0.040 kg
LLE 24x560mm 2400lm 935 HV ADV5	28003413	3,500 K	108 pc(s).	0.040 kg
LLE 24x560mm 2400lm 940 HV ADV5	89603234	4,000 K	108 pc(s).	0.040 kg

**Technical data**

Beam characteristic	120°
Ambient temperature $t_a$	-40 ... +65 °C
$t_p$ rated	50 °C
$t_c$	85 °C
$I_{rated}$	300 mA
$I_{max}$	540 mA
Max. permissible LF current ripple	595 mA
Max. permissible peak current	900 mA / max. 10 ms
Max. working voltage for insulation <sup>®</sup>	440 V
Insulation test voltage	1.88 kV
CTI of the printed circuit board	≥ 600
Colour tolerance	3 SDCM
ESD classification	Severity level 4
Risk group (IEC 62471) at ≤ 470 mA	RG0
Risk group (IEC 62471) at $I_{max}$	RG1
Classification acc. to IEC 62031	Built-in
Type of protection	IP00
Lumen maintenance L70B50	72,000 h
Guarantee (conditions at <a href="http://www.tridonic.com">www.tridonic.com</a> )	5 Year(s)

**Approval marks****Standards**

IEC 62031, IEC 62471, IEC 61000-4-2, IEC 62778, IEC 61547, UL 8750

Specific technical data

Type	Article number	Photometric code	Useful luminous flux at tp = 25 °C	Expected luminous flux at tp rated	Typ. forward current	Min. forward voltage at tp rated	Max. forward voltage at tp = 25 °C	Power consumption Pon at tp = 25 °C	Efficacy of the module at tp = 25 °C	Expected efficacy of the module at tp rated	Colour rendering index CRI
<b>Operating mode HE at 200 mA</b>											
LLE 24x70mm 325lm 930 HV ADV5 QTY4	28003972	930/359	-	172 lm	200 mA	5.2 V	5.6 V	-	-	157 lm/W	>>90
LLE 24x70mm 325lm 940 HV ADV5 QTY4	28003974	940/359	-	186 lm	200 mA	5.2 V	5.6 V	-	-	166 lm/W	>>90
LLE 24x140mm 650lm 927 HV ADV5	89603226	927/359	-	327 lm	200 mA	10.3 V	11.2 V	-	-	149 lm/W	>>90
LLE 24x140mm 650lm 930 HV ADV5	89603227	930/359	-	341 lm	200 mA	10.3 V	11.2 V	-	-	161 lm/W	>>90
LLE 24x140mm 650lm 935 HV ADV5	28003411	935/359	-	358 lm	200 mA	10.3 V	11.2 V	-	-	165 lm/W	>>90
LLE 24x140mm 650lm 940 HV ADV5	89603228	940/359	-	354 lm	200 mA	10.3 V	11.2 V	-	-	167 lm/W	>>90
LLE 24x280mm 1250lm 927 HV ADV5	89603229	927/359	-	663 lm	200 mA	20.7 V	22.4 V	-	-	154 lm/W	>>90
LLE 24x280mm 1250lm 930 HV ADV5	89603230	930/359	-	687 lm	200 mA	20.7 V	22.4 V	-	-	158 lm/W	>>90
LLE 24x280mm 1250lm 935 HV ADV5	28003412	935/359	-	709 lm	200 mA	20.7 V	22.4 V	-	-	163 lm/W	>>90
LLE 24x280mm 1250lm 940 HV ADV5	89603231	940/359	-	714 lm	200 mA	20.7 V	22.4 V	-	-	165 lm/W	>>90
LLE 24x560mm 2400lm 930 HV ADV5	89603233	930/359	-	1,375 lm	200 mA	41.4 V	44.8 V	-	-	159 lm/W	>>90
LLE 24x560mm 2400lm 935 HV ADV5	28003413	935/359	-	1,419 lm	200 mA	41.4 V	44.8 V	-	-	164 lm/W	>>90
LLE 24x560mm 2400lm 940 HV ADV5	89603234	940/359	-	1,435 lm	200 mA	41.4 V	44.8 V	-	-	166 lm/W	>>90
<b>Operating mode HE at 250 mA</b>											
LLE 24x70mm 325lm 930 HV ADV5 QTY4	28003972	930/359	-	211 lm	250 mA	5.2 V	5.7 V	-	-	152 lm/W	>>90
LLE 24x70mm 325lm 940 HV ADV5 QTY4	28003974	940/359	-	226 lm	250 mA	5.2 V	5.7 V	-	-	161 lm/W	>>90
LLE 24x140mm 650lm 927 HV ADV5	89603226	927/359	-	402 lm	250 mA	10.4 V	11.3 V	-	-	147 lm/W	>>90
LLE 24x140mm 650lm 930 HV ADV5	89603227	930/359	-	419 lm	250 mA	10.4 V	11.3 V	-	-	156 lm/W	>>90
LLE 24x140mm 650lm 935 HV ADV5	28003411	935/359	-	439 lm	250 mA	10.4 V	11.3 V	-	-	161 lm/W	>>90
LLE 24x140mm 650lm 940 HV ADV5	89603228	940/359	-	442 lm	250 mA	10.4 V	11.3 V	-	-	163 lm/W	>>90
LLE 24x280mm 1250lm 927 HV ADV5	89603229	927/359	-	815 lm	250 mA	20.9 V	22.6 V	-	-	149 lm/W	>>90
LLE 24x280mm 1250lm 930 HV ADV5	89603230	930/359	-	843 lm	250 mA	20.9 V	22.6 V	-	-	153 lm/W	>>90
LLE 24x280mm 1250lm 935 HV ADV5	28003412	935/359	-	874 lm	250 mA	20.9 V	22.6 V	-	-	159 lm/W	>>90
LLE 24x280mm 1250lm 940 HV ADV5	89603231	940/359	-	879 lm	250 mA	20.9 V	22.6 V	-	-	161 lm/W	>>90
LLE 24x560mm 2400lm 930 HV ADV5	89603233	930/359	-	1,688 lm	250 mA	41.8 V	45.3 V	-	-	155 lm/W	>>90
LLE 24x560mm 2400lm 935 HV ADV5	28003413	935/359	-	1,749 lm	250 mA	41.8 V	45.3 V	-	-	160 lm/W	>>90
LLE 24x560mm 2400lm 940 HV ADV5	89603234	940/359	-	1,767 lm	250 mA	41.8 V	45.3 V	-	-	162 lm/W	>>90
<b>Operating mode HE at 275 mA</b>											
LLE 24x70mm 325lm 930 HV ADV5 QTY4	28003972	930/359	-	230 lm	275 mA	5.3 V	5.7 V	-	-	149 lm/W	>>90
LLE 24x70mm 325lm 940 HV ADV5 QTY4	28003974	940/359	-	246 lm	275 mA	5.3 V	5.7 V	-	-	158 lm/W	>>90
LLE 24x140mm 650lm 927 HV ADV5	89603226	927/359	-	435 lm	275 mA	10.5 V	11.4 V	-	-	144 lm/W	>>90
LLE 24x140mm 650lm 930 HV ADV5	89603227	930/359	-	453 lm	275 mA	10.5 V	11.4 V	-	-	153 lm/W	>>90
LLE 24x140mm 650lm 935 HV ADV5	28003411	935/359	-	475 lm	275 mA	10.5 V	11.4 V	-	-	157 lm/W	>>90
LLE 24x140mm 650lm 940 HV ADV5	89603228	940/359	-	476 lm	275 mA	10.5 V	11.4 V	-	-	160 lm/W	>>90
LLE 24x280mm 1250lm 927 HV ADV5	89603229	927/359	-	880 lm	275 mA	21.0 V	22.7 V	-	-	146 lm/W	>>90
LLE 24x280mm 1250lm 930 HV ADV5	89603230	930/359	-	912 lm	275 mA	21.0 V	22.7 V	-	-	150 lm/W	>>90
LLE 24x280mm 1250lm 935 HV ADV5	28003412	935/359	-	944 lm	275 mA	21.0 V	22.7 V	-	-	155 lm/W	>>90
LLE 24x280mm 1250lm 940 HV ADV5	89603231	940/359	-	952 lm	275 mA	21.0 V	22.7 V	-	-	158 lm/W	>>90
LLE 24x560mm 2400lm 930 HV ADV5	89603233	930/359	-	1,824 lm	275 mA	42.0 V	45.5 V	-	-	152 lm/W	>>90
LLE 24x560mm 2400lm 935 HV ADV5	28003413	935/359	-	1,889 lm	275 mA	42.0 V	45.5 V	-	-	156 lm/W	>>90
LLE 24x560mm 2400lm 940 HV ADV5	89603234	940/359	-	1,913 lm	275 mA	42.0 V	45.5 V	-	-	159 lm/W	>>90
<b>Operating mode NM at 300 mA</b>											
LLE 24x70mm 325lm 930 HV ADV5 QTY4	28003972	930/359	255 lm	250 lm	300 mA	5.3 V	5.7 V	1.7 W	150 lm/W	147 lm/W	>>90
LLE 24x70mm 325lm 940 HV ADV5 QTY4	28003974	940/359	271 lm	266 lm	300 mA	5.3 V	5.7 V	1.7 W	159 lm/W	156 lm/W	>>90
LLE 24x140mm 650lm 927 HV ADV5	89603226	927/359	484 lm	471 lm	300 mA	10.5 V	11.4 V	3.3 W	147 lm/W	143 lm/W	>>90
LLE 24x140mm 650lm 930 HV ADV5	89603227	930/359	507 lm	492 lm	300 mA	10.5 V	11.4 V	3.3 W	154 lm/W	151 lm/W	>>90
LLE 24x140mm 650lm 935 HV ADV5	28003411	935/359	525 lm	510 lm	300 mA	10.5 V	11.4 V	3.3 W	159 lm/W	155 lm/W	>>90
LLE 24x140mm 650lm 940 HV ADV5	89603228	940/359	529 lm	514 lm	300 mA	10.5 V	11.4 V	3.3 W	160 lm/W	157 lm/W	>>90
LLE 24x280mm 1250lm 927 HV ADV5	89603229	927/359	979 lm	954 lm	300 mA	21.1 V	22.8 V	6.7 W	148 lm/W	144 lm/W	>>90
LLE 24x280mm 1250lm 930 HV ADV5	89603230	930/359	1,014 lm	985 lm	300 mA	21.1 V	22.8 V	6.7 W	151 lm/W	148 lm/W	>>90
LLE 24x280mm 1250lm 935 HV ADV5	28003412	935/359	1,049 lm	1,019 lm	300 mA	21.1 V	22.8 V	6.7 W	157 lm/W	153 lm/W	>>90
LLE 24x280mm 1250lm 940 HV ADV5	89603231	940/359	1,059 lm	1,030 lm	300 mA	21.1 V	22.8 V	6.7 W	158 lm/W	155 lm/W	>>90
LLE 24x560mm 2400lm 930 HV ADV5	89603233	930/359	2,029 lm	1,970 lm	300 mA	42.2 V	45.7 V	13.3 W	153 lm/W	150 lm/W	>>90
LLE 24x560mm 2400lm 935 HV ADV5	28003413	935/359	2,099 lm	2,039 lm	300 mA	42.2 V	45.7 V	13.3 W	158 lm/W	154 lm/W	>>90
LLE 24x560mm 2400lm 940 HV ADV5	89603234	940/359	2,118 lm	2,059 lm	300 mA	42.2 V	45.7 V	13.3 W	159 lm/W	156 lm/W	>>90
<b>Operating mode HO at 350 mA</b>											
LLE 24x70mm 325lm 930 HV ADV5 QTY4	28003972	930/359	-	289 lm	350 mA	5.3 V	5.8 V	-	-	145 lm/W	>>90
LLE 24x70mm 325lm 940 HV ADV5 QTY4	28003974	940/359	-	306 lm	350 mA	5.3 V	5.8 V	-	-	154 lm/W	>>90
LLE 24x140mm 650lm 927 HV ADV5	89603226	927/359	-	545 lm	350 mA	10.6 V	11.5 V	-	-	140 lm/W	>>90
LLE 24x140mm 650lm 930 HV ADV5	89603227	930/359	-	570 lm	350 mA	10.6 V	11.5 V	-	-	149 lm/W	>>90
LLE 24x140mm 650lm 935 HV ADV5	28003411	935/359	-	596 lm	350 mA	10.6 V	11.5 V	-	-	153 lm/W	>>90
LLE 24x140mm 650lm 940 HV ADV5	89603228	940/359	-	602 lm	350 mA	10.6 V	11.5 V	-	-	155 lm/W	>>90
LLE 24x280mm 1250lm 927 HV ADV5	89603229	927/359	-	1,104 lm	350 mA	21.3 V	23.0 V	-	-	142 lm/W	>>90
LLE 24x280mm 1250lm 930 HV ADV5	89603230	930/359	-	1,141 lm	350 mA	21.3 V	23.0 V	-	-	146 lm/W	>>90
LLE 24x280mm 1250lm 935 HV ADV5	28003412	935/359	-	1,179 lm	350 mA	21.3 V	23.0 V	-	-	151 lm/W	>>90
LLE 24x280mm 1250lm 940 HV ADV5	89603231	940/359	-	1,195 lm	350 mA	21.3 V	23.0 V	-	-	153 lm/W	>>90

Type	Article number	Photometric code	Useful luminous flux at tp = 25 °C <sup>②</sup>	Expected luminous flux at tp rated <sup>③</sup>	Typ. forward current	Min. forward voltage at tp rated	Max. forward voltage at tp = 25 °C	Power consumption Pon at tp = 25 °C <sup>⑤</sup>	Efficacy of the module at tp = 25 °C	Expected efficacy of the module at tp rated	Colour rendering index CRI
LLE 24x560mm 2400lm 930 HV ADV5	89603233	930/359	-	2,292 lm	350 mA	42.5 V	46.1 V	-	-	148 lm/W	>>90
LLE 24x560mm 2400lm 935 HV ADV5	28003413	935/359	-	2,369 lm	350 mA	42.5 V	46.1 V	-	-	152 lm/W	>>90
LLE 24x560mm 2400lm 940 HV ADV5	89603234	940/359	-	2,401 lm	350 mA	42.5 V	46.1 V	-	-	154 lm/W	>>90
<b>Operating mode HO at 400 mA</b>											
LLE 24x70mm 325lm 930 HV ADV5 QTY4	28003972	930/359	-	329 lm	400 mA	5.4 V	5.8 V	-	-	144 lm/W	>>90
LLE 24x70mm 325lm 940 HV ADV5 QTY4	28003974	940/359	-	351 lm	400 mA	5.4 V	5.8 V	-	-	154 lm/W	>>90
LLE 24x140mm 650lm 927 HV ADV5	89603226	927/359	-	625 lm	400 mA	10.7 V	11.6 V	-	-	139 lm/W	>>90
LLE 24x140mm 650lm 930 HV ADV5	89603227	930/359	-	653 lm	400 mA	10.7 V	11.6 V	-	-	148 lm/W	>>90
LLE 24x140mm 650lm 935 HV ADV5	28003411	935/359	-	687 lm	400 mA	10.7 V	11.6 V	-	-	152 lm/W	>>90
LLE 24x140mm 650lm 940 HV ADV5	89603228	940/359	-	684 lm	400 mA	10.7 V	11.6 V	-	-	155 lm/W	>>90
LLE 24x280mm 1250lm 927 HV ADV5	89603229	927/359	-	1,266 lm	400 mA	21.5 V	23.2 V	-	-	141 lm/W	>>90
LLE 24x280mm 1250lm 930 HV ADV5	89603220	930/359	-	1,307 lm	400 mA	21.5 V	23.2 V	-	-	146 lm/W	>>90
LLE 24x280mm 1250lm 935 HV ADV5	28003412	935/359	-	1,359 lm	400 mA	21.5 V	23.2 V	-	-	150 lm/W	>>90
LLE 24x280mm 1250lm 940 HV ADV5	89603231	940/359	-	1,370 lm	400 mA	21.5 V	23.2 V	-	-	153 lm/W	>>90
LLE 24x560mm 2400lm 930 HV ADV5	89603233	930/359	-	2,624 lm	400 mA	42.9 V	46.4 V	-	-	147 lm/W	>>90
LLE 24x560mm 2400lm 935 HV ADV5	28003413	935/359	-	2,709 lm	400 mA	42.9 V	46.4 V	-	-	151 lm/W	>>90
LLE 24x560mm 2400lm 940 HV ADV5	89603234	940/359	-	2,752 lm	400 mA	42.9 V	46.4 V	-	-	154 lm/W	>>90
<b>Operating mode HO at 500 mA</b>											
LLE 24x70mm 325lm 930 HV ADV5 QTY4	28003972	930/359	-	402 lm	500 mA	5.5 V	5.9 V	-	-	138 lm/W	>>90
LLE 24x70mm 325lm 940 HV ADV5 QTY4	28003974	940/359	-	427 lm	500 mA	5.5 V	5.9 V	-	-	147 lm/W	>>90
LLE 24x140mm 650lm 927 HV ADV5	89603226	927/359	-	759 lm	500 mA	10.9 V	11.8 V	-	-	133 lm/W	>>90
LLE 24x140mm 650lm 930 HV ADV5	89603227	930/359	-	795 lm	500 mA	10.9 V	11.8 V	-	-	142 lm/W	>>90
LLE 24x140mm 650lm 935 HV ADV5	28003411	935/359	-	833 lm	500 mA	10.9 V	11.8 V	-	-	146 lm/W	>>90
LLE 24x140mm 650lm 940 HV ADV5	89603228	940/359	-	825 lm	500 mA	10.9 V	11.8 V	-	-	148 lm/W	>>90
LLE 24x280mm 1250lm 927 HV ADV5	89603229	927/359	-	1,537 lm	500 mA	21.8 V	23.5 V	-	-	135 lm/W	>>90
LLE 24x280mm 1250lm 930 HV ADV5	89603230	930/359	-	1,589 lm	500 mA	21.8 V	23.5 V	-	-	140 lm/W	>>90
LLE 24x280mm 1250lm 935 HV ADV5	28003412	935/359	-	1,648 lm	500 mA	21.8 V	23.5 V	-	-	144 lm/W	>>90
LLE 24x280mm 1250lm 940 HV ADV5	89603231	940/359	-	1,652 lm	500 mA	21.8 V	23.5 V	-	-	145 lm/W	>>90
LLE 24x560mm 2400lm 930 HV ADV5	89603233	930/359	-	3,180 lm	500 mA	43.6 V	47.1 V	-	-	141 lm/W	>>90
LLE 24x560mm 2400lm 935 HV ADV5	28003413	935/359	-	3,288 lm	500 mA	43.6 V	47.1 V	-	-	145 lm/W	>>90
LLE 24x560mm 2400lm 940 HV ADV5	89603234	940/359	-	3,328 lm	500 mA	43.6 V	47.1 V	-	-	147 lm/W	>>90

② If mounted with M4 screws and plastic washers.

③ Tolerance of useful light flux - 0 % / + 15 %. Measurement uncertainty ± 10 %.

④ Tolerance of expected light flux - 0 % / + 15 %. Measurement uncertainty ± 10 %. Based on calculation.

⑤ Measurement tolerance forward voltage: ±0.1V.

⑥ Tolerance of power consumption Pon ± 10 %. Measurement uncertainty ± 5 %.

## LINEAR COVER LLE

Accessory

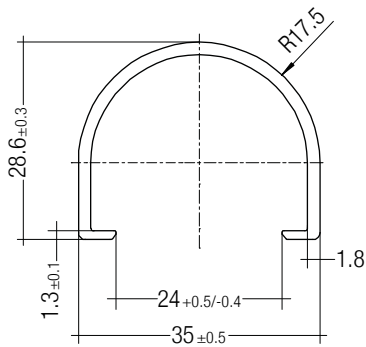

## Product description

- \_ LINEAR COVER for LLE
- \_ Protection against direct touch for non-SELV applications (recommendation LLE 20: use all fixing points and screwed Endcap, recommendation LLE 24: use all fixing points)
- \_ Fast snap on mounting on to LLE 20: with M4 screws and plastic washers, to LLE 24: with clips or plastic washers
- \_ High transmission: transparent, semi-transparent and diffuse
- \_ Material: PMMA
- \_ Tolerances:  $\pm 1$  mm for 597 mm length (ends finished), + 10 mm from length 1,150 mm (ends raw)

## Website

<http://www.tridonic.com/28000338>



## Ordering data

Type	Article number	Colour	Length L	Efficiency	Packaging, carton	Weight per pc.
LINEAR COVER SY Transparent 1600mm	28000338	Transparent	1,600 mm	94 %	12 pc(s).	0.272 kg
LINEAR COVER SY Frosted 1800mm	28000437	Semi-transparent	1,800 mm	87 %	12 pc(s).	0.308 kg
LINEAR COVER SY Frosted 1600mm	28000339	Semi-transparent	1,600 mm	87 %	12 pc(s).	0.272 kg
LINEAR COVER SY Frosted 1500mm	28000435	Semi-transparent	1,500 mm	87 %	12 pc(s).	0.244 kg
LINEAR COVER SY Frosted 1200mm	28000422	Semi-transparent	1,200 mm	87 %	12 pc(s).	0.205 kg
LINEAR COVER SY Frosted 597mm	28000340	Semi-transparent	597 mm	87 %	12 pc(s).	0.102 kg
LINEAR COVER SY Diffuse 1800mm	28000438	Diffuse	1,800 mm	76 %	12 pc(s).	0.308 kg
LINEAR COVER SY Diffuse 1600mm	28000341	Diffuse	1,600 mm	76 %	12 pc(s).	0.272 kg
LINEAR COVER SY Diffuse 1500mm	28000436	Diffuse	1,500 mm	76 %	12 pc(s).	0.257 kg
LINEAR COVER SY Diffuse 1200mm	28000434	Diffuse	1,200 mm	76 %	12 pc(s).	0.205 kg
LINEAR COVER SY Diffuse 597mm	28000342	Diffuse	597 mm	76 %	12 pc(s).	0.102 kg

## ACL ENDCAP LLE

Accessory

**Product description**

- \_ ENDCAP for LLE
- \_ PUSH-FIX: Fast snap on mounting (sheet thickness 0.5 – 1.0 mm), for drilling hole 4 mm
- \_ SCREW-FIX: Screw mounting with EJOT Delta PT WN 5451 30x8 (not included), tightening torque 0.7 Nm
- \_ Clip made of polycarbonate

**Website**

<http://www.tridonic.com/28001037>

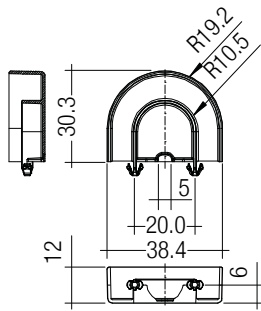
**Ordering data**

Type	Article number	Colour	Packaging, carton	Weight per pc.
ACL ENDCAP LLE24 PUSH-FIX	28001037	White	480 pc(s).	0.003 kg
ACL ENDCAP LLE24 SCREW-FIX	28002315	White	480 pc(s).	0.003 kg

## ACL LINEAR LENS 24mm

Accessory

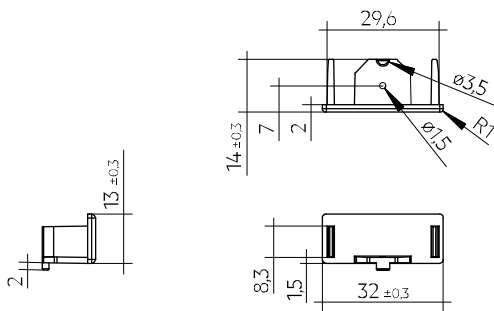
**Product description LINEAR LENS**

- \_ Linear lens for LLE 20 / 24
- \_ Available with different beam characteristics
- \_ Protection against direct touch for non-SELV applications (recommendation: use all fixing points)
- \_ Fast snap on mounting on to LLE 20: with M4 screws and plastic washers, to LLE 24: with clips or plastic washers
- \_ Recommendation: Fastening with screws and plastic washers, see 2.3 Heat sink specifications in data sheet
- \_ Material: PMMA
- \_ Available lengths: 1,200, 1,500 and 1,800 mm, Tolerance: + 10 mm (ends raw)
- \_ Max. permissible temperature 80 °C
- \_ Photometric data available on website

**Product description Endcap**

- \_ ENDCAP for LINEAR LENS 24mm INTENSE, ASY and DASY
- \_ Mounting by clipping in and screwing from below using screw EJOT Delta PT WN 5451 20x4, tightening torque 0.7 Nm
- \_ Made of Polyamide UL94 V0

**Website**

<http://www.tridonic.com/28001428>

**Ordering data**

Type	Article number	Length L	Beam characteristic	Efficiency	Packaging, carton	Weight per pc.
ACL LINEAR LENS 24x1200mm 60°	28001428	1,200 mm	60°	97 %	21 pc(s).	0.196 kg
ACL LINEAR LENS 24x1200mm 90°	28001429	1,200 mm	90°	97 %	21 pc(s).	0.165 kg
ACL LINEAR LENS 24x1500mm 60°	28000953	1,500 mm	60°	97 %	21 pc(s).	0.261 kg
ACL LINEAR LENS 24x1500mm 90°	28000955	1,500 mm	90°	97 %	21 pc(s).	0.221 kg
ACL LINEAR LENS 24x1200mm INTENSE	28002024	1,200 mm	40°	95 %	18 pc(s).	0.261 kg
ACL LINEAR LENS 24x1500mm INTENSE	28002025	1,500 mm	40°	95 %	18 pc(s).	0.326 kg
ACL LINEAR LENS 24x1800mm INTENSE	28002026	1,800 mm	40°	95 %	18 pc(s).	0.392 kg
ACL LINEAR LENS 24x1200mm BATWING	28002027	1,200 mm	batwing	95 %	18 pc(s).	0.275 kg
ACL LINEAR LENS 24x1500mm BATWING	28002028	1,500 mm	batwing	95 %	18 pc(s).	0.344 kg
ACL LINEAR LENS 24x1800mm BATWING	28002029	1,800 mm	batwing	95 %	18 pc(s).	0.412 kg
ACL LINEAR LENS 24x1200mm ASY	28002030	1,200 mm	asymmetric	95 %	18 pc(s).	0.250 kg
ACL LINEAR LENS 24x1500mm ASY	28002031	1,500 mm	asymmetric	95 %	18 pc(s).	0.312 kg
ACL LINEAR LENS 24x1800mm ASY	28002032	1,800 mm	asymmetric	95 %	18 pc(s).	0.375 kg
ACL LINEAR LENS 24x1200mm DASY	28002033	1,200 mm	double asymmetric	92 %	18 pc(s).	0.249 kg
ACL LINEAR LENS 24x1500mm DASY	28002034	1,500 mm	double asymmetric	92 %	18 pc(s).	0.311 kg
ACL LINEAR LENS 24x1800mm DASY	28002035	1,800 mm	double asymmetric	92 %	18 pc(s).	0.373 kg
ACL Endcap LENS 24mm PSF	28002669	-	-	-	3,600 pc(s).	0.003 kg



## ACL CLIP 4.3mm

Accessory

**Product description**

- \_ Clip for fixation of LED modules with 4.3 mm holes
- \_ Fast snap on mounting (sheet thickness 0.5 – 1.0 mm for PUSH-FIX and 1 – 2 mm for PUSH-FIX Long)
- \_ For drilling hole 4 mm
- \_ Clip made of polycarbonate
- \_ Minimum sales quantity 500 pcs.

**Website**

<http://www.tridonic.com/28001036>

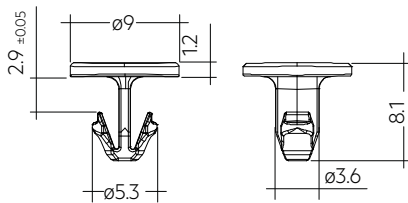
**Ordering data**

Type	Article number	Colour	Packaging, bag <sup>①</sup>	Weight per pc.
ACL CLIP 4.3mm PUSH-FIX	28001036	White	500 pc(s).	0.001 kg
ACL CLIP 4,3mm PUSH-FIX Long	28002314	Transparent	500 pc(s).	0.001 kg

① Minimum sales quantity 500 pcs.

## ACL BRIDGE LLE24/40

Accessory

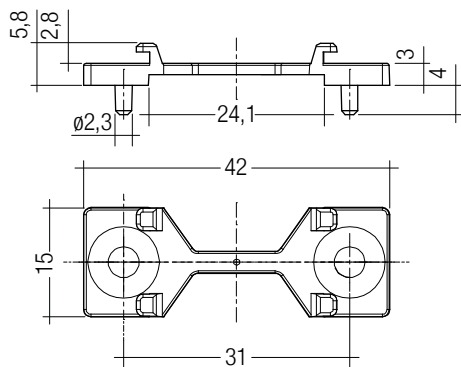
**Product description**

- \_ Enables the fixation of 24 mm wide Tridonic LED modules to fixtures made for 40 mm wide modules
- \_ Ideal for extruded aluminium gear trays made for 40 mm modules with pre-alignment knobs
- \_ Clip-on for LINEAR COVER and LINEAR LENS <sup>①</sup>
- \_ For LLE 24 with 280 mm module minimum 2 bridges required
- \_ For LLE 24 with 560 mm module minimum 3 bridges required
- \_ Fixation via M3 or M4 countersunk screw, max. tightening torque 0.5 Nm
- \_ Material: white polycarbonate
- \_ Minimum sales quantity 600 pcs.

<sup>①</sup> Beam characteristics will change due to the elevated fixation (see photometric files for details).

**Website**

<http://www.tridonic.com/28001205>

**Ordering data**

Type	Article number	Colour	Packaging, carton	Weight per pc.
ACL BRIDGE LLE24/40 SCREW-FIX	28001205	White	600 pc(s).	0.001 kg

## 1. Standards

IEC 62031  
IEC 62471  
IEC 61000-4-2  
IEC 62778  
IEC 61547  
UL 8750 (for CLASS2 circuits and dry locations)

### 1.1 Photometric code

Key for photometric code, e. g. 830 / 349

1 <sup>st</sup> digit	2 <sup>nd</sup> + 3 <sup>rd</sup> digit	4 <sup>th</sup> digit	5 <sup>th</sup> digit	6 <sup>th</sup> digit	
Code	CRI	Colour temperature in Kelvin x 100	MacAdam initial	MacAdam after 25% of the lifetime (max.6000h)	
7	70 – 79			Luminous flux after 25% of the lifetime (max.6000h)	
8	80 – 89			Code	Luminous flux
9	≥90			7	≥ 70 %
				8	≥ 80 %
				9	≥ 90 %

### 1.2 Energy classification

Type	Colour temperature	Forward current	Energy classification	Energy consumption
LLE 24x70mm 325lm 930 HV ADV5 QTY4	3.000 K	300 mA	D	2 kWh / 1000 h
LLE 24x70mm 325lm 940 HV ADV5 QTY4	4.000 K	300 mA	D	2 kWh / 1000 h
LLE 24x140mm 650lm 927 HV ADV5	2.700 K	300 mA	D	4 kWh / 1000 h
LLE 24x140mm 650lm 930 HV ADV5	3.000 K	300 mA	D	4 kWh / 1000 h
LLE 24x140mm 650lm 935 HV ADV5	3.500 K	300 mA	D	4 kWh / 1000 h
LLE 24x140mm 650lm 940 HV ADV5	4.000 K	300 mA	D	4 kWh / 1000 h
LLE 24x280mm 1250lm 927 HV ADV5	2.700 K	300 mA	D	7 kWh / 1000 h
LLE 24x280mm 1250lm 930 HV ADV5	3.000 K	300 mA	D	7 kWh / 1000 h
LLE 24x280mm 1250lm 935 HV ADV5	3.500 K	300 mA	D	7 kWh / 1000 h
LLE 24x280mm 1250lm 940 HV ADV5	4.000 K	300 mA	D	7 kWh / 1000 h
LLE 24x560mm 2400lm 930 HV ADV5	3.000 K	300 mA	D	14 kWh / 1000 h
LLE 24x560mm 2400lm 935 HV ADV5	3.500 K	300 mA	D	14 kWh / 1000 h
LLE 24x560mm 2400lm 940 HV ADV5	4.000 K	300 mA	D	14 kWh / 1000 h

Energy label and further information at [www.tridonic.com](http://www.tridonic.com) in the certificates tab of the corresponding product page and at the EPREL data base <https://eprel.ec.europa.eu/>

## 2. Thermal details

### 2.1 tc point, ambient temperature and lifetime

The temperature at tp reference point is crucial for the light output and lifetime of a LED product.

For LLE a tp temperature of 50 °C has to be complied in order to achieve an optimum between heat sink requirements, light output and lifetime.

Compliance with the maximum permissible reference temperature at the tc point must be checked under operating conditions in a thermally stable state. The maximum value must be determined under worst-case conditions for the relevant application.

The tc and tp temperature of LED modules from Tridonic are measured at the same reference point.

### 2.2 Storage and humidity

Storage temperature	-40...+80 °C
---------------------	--------------

Operation only in non condensing environment.

Humidity during processing of the module should be between 30 to 70 %.

### 2.3 Heat sink values

#### LLE 24x70mm 325lm ADV5

ta	tp	Forward current	R <sub>th, hs-a</sub>	Cooling area
25 °C	50 °C	300 mA	2897 K/W	23 cm <sup>2</sup>
25 °C	50 °C	500 mA	1721 K/W	39 cm <sup>2</sup>
35 °C	50 °C	300 mA	1737 K/W	38 cm <sup>2</sup>
35 °C	50 °C	500 mA	1032 K/W	65 cm <sup>2</sup>
40 °C	50 °C	300 mA	1157 K/W	58 cm <sup>2</sup>
40 °C	50 °C	500 mA	687 K/W	97 cm <sup>2</sup>
45 °C	50 °C	300 mA	577 K/W	115 cm <sup>2</sup>
45 °C	50 °C	500 mA	342 K/W	195 cm <sup>2</sup>

#### LLE 24x140mm 650lm ADV5

ta	tp	Forward current	R <sub>th, hs-a</sub>	Cooling area
25 °C	50 °C	300 mA	1449 K/W	46 cm <sup>2</sup>
25 °C	50 °C	500 mA	861 K/W	77 cm <sup>2</sup>
35 °C	50 °C	300 mA	869 K/W	77 cm <sup>2</sup>
35 °C	50 °C	500 mA	516 K/W	129 cm <sup>2</sup>
40 °C	50 °C	300 mA	579 K/W	115 cm <sup>2</sup>
40 °C	50 °C	500 mA	343 K/W	194 cm <sup>2</sup>
45 °C	50 °C	300 mA	289 K/W	231 cm <sup>2</sup>
45 °C	50 °C	500 mA	171 K/W	390 cm <sup>2</sup>

#### LLE 24x280mm 1250lm ADV5

ta	tp	Forward current	R <sub>th, hs-a</sub>	Cooling area
25 °C	50 °C	300 mA	725 K/W	92 cm <sup>2</sup>
25 °C	50 °C	500 mA	430 K/W	155 cm <sup>2</sup>
35 °C	50 °C	300 mA	435 K/W	153 cm <sup>2</sup>
35 °C	50 °C	500 mA	258 K/W	259 cm <sup>2</sup>
40 °C	50 °C	300 mA	290 K/W	230 cm <sup>2</sup>
40 °C	50 °C	500 mA	172 K/W	388 cm <sup>2</sup>
45 °C	50 °C	300 mA	144 K/W	462 cm <sup>2</sup>
45 °C	50 °C	500 mA	085 K/W	780 cm <sup>2</sup>

#### LLE 24x560mm 2400lm ADV5

ta	tp	Forward current	R <sub>th, hs-a</sub>	Cooling area
25 °C	50 °C	300 mA	362 K/W	184 cm <sup>2</sup>
25 °C	50 °C	500 mA	215 K/W	310 cm <sup>2</sup>
35 °C	50 °C	300 mA	217 K/W	307 cm <sup>2</sup>
35 °C	50 °C	500 mA	129 K/W	517 cm <sup>2</sup>
40 °C	50 °C	300 mA	145 K/W	460 cm <sup>2</sup>
40 °C	50 °C	500 mA	086 K/W	776 cm <sup>2</sup>
45 °C	50 °C	300 mA	072 K/W	923 cm <sup>2</sup>
45 °C	50 °C	500 mA	043 K/W	1,559 cm <sup>2</sup>

### Notes

The actual cooling surface can differ because of the material, the structural shape, outside influences and the installation situation. Depending on the heat sink a heat conducting paste or heat conducting film might be necessary to keep the specified tp temperature.

### 3. Installation / wiring

#### 3.1 Electrical supply/choice of LED driver

LLE modules from Tridonic are not protected against overvoltages, overcurrents, overloads or short-circuit currents. Safe and reliable operation can only be guaranteed in conjunction with a LED driver which complies with the relevant standards. The use of LED driver from Tridonic in combination with LLE modules guarantees the necessary protection for safe and reliable operation.

If a LED driver other than Tridonic is used, it must provide the following protection:

- Short-circuit protection
- Overload protection
- Overtemperature protection



LLE modules must be supplied by a constant current LED driver. Operation with a constant voltage LED driver will lead to an irreversible damage of the module.

Wrong polarity can damage the LLE.

The LLE module is designed for serial wiring.

With parallel wiring tolerance-related differences in output are possible (thermal stress of the module) and can cause differences in brightness.

If a wire breaks or a complete module fails then the current passing through the other module increases. This may reduce its life considerably.

Max. 8 pieces 280 mm modules or 4 pieces 560 mm modules may be connected in parallel.

LLE can be operated either from SELV LED drivers or from LED drivers with LV output voltage.



LLE are basic insulated up to 440 V (if mounted with M4 screws with head diameter 7 mm in combination with plastic washers) against ground and can be mounted directly on earthed metal parts of the luminaire. If the max. output voltage of the LED driver (also against earth) is above 440 V, an additional insulation between LED module and heat sink is required (for example by insulated thermal pads) or by a suitable luminaire construction.

At voltages > 60 V an additional protection against direct touch (test finger) to the light emitting side of the module has to be guaranteed.

This is typically achieved by means of a non removable light distributor over the module.

3.2 Wiring

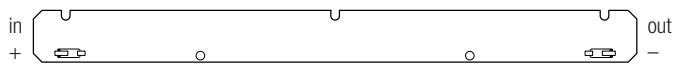

Wiring examples for serial wiring

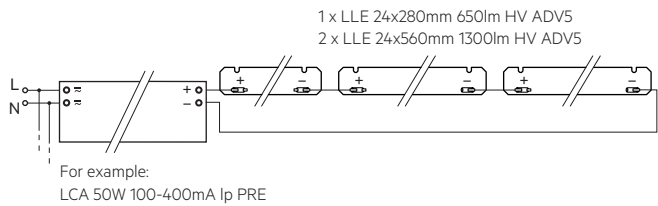
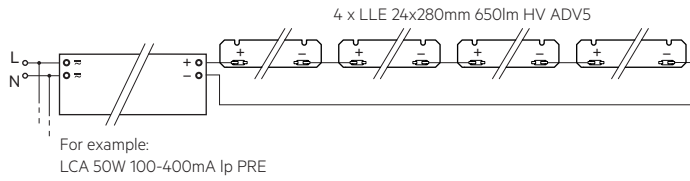

Wiring examples for parallel wiring

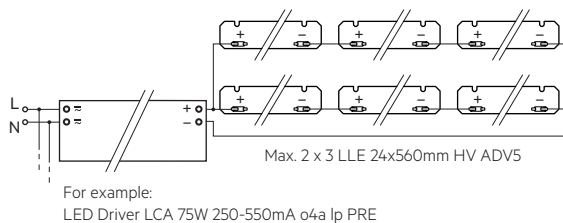
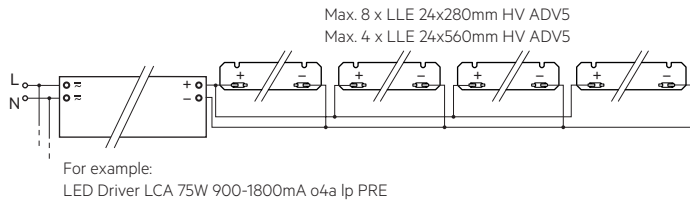

3.3 Wiring type and cross section

For wiring use stranded wire with ferrules or solid wire from 0.2 to 0.75 mm<sup>2</sup>. For the push-wire connection you have to strip the insulation (8–9 mm).

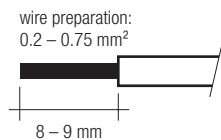

To remove the wires use a suitabel tool (e.g. Microcon release pin) or through twist and pull.

3.4 Mounting instruction



None of the components of the LLE (substrate, LED, electronic components etc.) may be exposed to tensile or compressive stresses.

Max. torque for fixing: 0.5 Nm.

The LED modules are mounted onto a heat sink with min. 3 screws per module or ACL CLIP 4.3mm.

The LLE 24x70mm module is delivered as a board of 280mm (4 pcs.) and must be separated.

Only touch the module at the edge to separate the modules (see marking below).

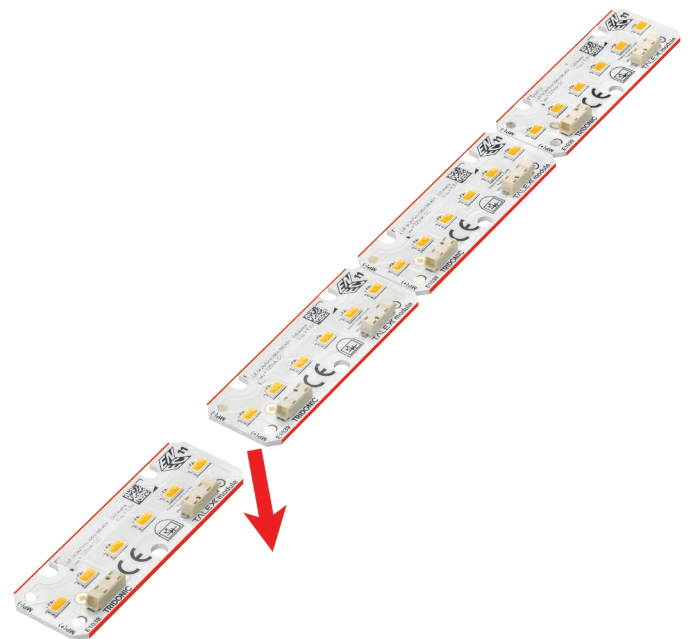

Chemical substance may harm the LED module. Chemical reactions could lead to colour shift, reduced luminous flux or a total failure of the module caused by corrosion of electrical connections.

Materials which are used in LED applications (e.g. sealings, adhesives) must not produce dissolver gas. They must not be condensation curing based, acetate curing based or contain sulfur, chlorine or phthalate.

Avoid corrosive atmosphere during usage and storage.

3.5 EOS/ESD safety guidelines



The device / module contains components that are sensitive to electrostatic discharge and may only be installed in the factory and on site if appropriate EOS/ESD protection measures have been taken. No special measures need be taken for devices/modules with enclosed casings (contact with the pc board not possible), just normal installation practice. Please note the requirements set out in the document EOS / ESD guidelines (Guideline\_EOS\_ESD.pdf) at: <http://www.tridonic.com/esd-protection>

## 4. Lifetime

### 4.1 Lifetime, lumen maintenance and failure rate

The light output of an LED module decreases over the lifetime, this is characterized with the L value.

L70 means that the LED module will give 70 % of its initial luminous flux.

This value is always related to the number of operation hours and therefore defines the lifetime of an LED module.

As the L value is a statistical value and the lumen maintenance may vary over the delivered LED modules.

The B value defines the amount of modules which are below the specific L value, e.g. L70B10 means 10 % of the LED modules are below 70 % of the initial luminous flux, respectively 90 % will be above 70 % of the initial value.

In addition the percentage of failed modules (fatal failure) is characterized by the C value.

The F value is the combination of the B and C value. That means for F degradation and complete failures are considered, e.g. L70F10 means 10 % of the LED modules may fail or be below 70 % of the initial luminous flux.

### 4.2 Lumen maintenance for LLE 24mm HV ADV5

Forward current	tp tempera- ture	L90 / F10	L90 / F50	L80 / F10	L80 / F50	L70 / F10	L70 / F50
150 mA	45 °C	42,000 h	57,000 h	>72,000 h	>72,000 h	>72,000 h	>72,000 h
	50 °C	41,000 h	55,000 h	>72,000 h	>72,000 h	>72,000 h	>72,000 h
	55 °C	40,000 h	54,000 h	>72,000 h	>72,000 h	>72,000 h	>72,000 h
	60 °C	39,000 h	52,000 h	>72,000 h	>72,000 h	>72,000 h	>72,000 h
	65 °C	38,000 h	50,000 h	>72,000 h	>72,000 h	>72,000 h	>72,000 h
	70 °C	38,000 h	49,000 h	>72,000 h	>72,000 h	>72,000 h	>72,000 h
	75 °C	37,000 h	47,000 h	>72,000 h	>72,000 h	>72,000 h	>72,000 h
	80 °C	36,000 h	46,000 h	>72,000 h	>72,000 h	>72,000 h	>72,000 h
	85 °C	35,000 h	45,000 h	>72,000 h	>72,000 h	>72,000 h	>72,000 h
	200 mA	40 °C	43,000 h	58,000 h	>72,000 h	>72,000 h	>72,000 h
45 °C		42,000 h	57,000 h	>72,000 h	>72,000 h	>72,000 h	>72,000 h
50 °C		41,000 h	55,000 h	>72,000 h	>72,000 h	>72,000 h	>72,000 h
55 °C		40,000 h	53,000 h	>72,000 h	>72,000 h	>72,000 h	>72,000 h
60 °C		39,000 h	51,000 h	>72,000 h	>72,000 h	>72,000 h	>72,000 h
65 °C		38,000 h	50,000 h	>72,000 h	>72,000 h	>72,000 h	>72,000 h
70 °C		37,000 h	48,000 h	>72,000 h	>72,000 h	>72,000 h	>72,000 h
75 °C		36,000 h	47,000 h	>72,000 h	>72,000 h	>72,000 h	>72,000 h
80 °C		36,000 h	45,000 h	>72,000 h	>72,000 h	>72,000 h	>72,000 h
85 °C		35,000 h	44,000 h	>72,000 h	>72,000 h	>72,000 h	>72,000 h
300 mA	40 °C	42,000 h	58,000 h	>72,000 h	>72,000 h	>72,000 h	>72,000 h
	45 °C	41,000 h	56,000 h	>72,000 h	>72,000 h	>72,000 h	>72,000 h
	50 °C	40,000 h	54,000 h	>72,000 h	>72,000 h	>72,000 h	>72,000 h
	55 °C	40,000 h	52,000 h	>72,000 h	>72,000 h	>72,000 h	>72,000 h
	60 °C	39,000 h	51,000 h	>72,000 h	>72,000 h	>72,000 h	>72,000 h
	65 °C	38,000 h	49,000 h	>72,000 h	>72,000 h	>72,000 h	>72,000 h
	70 °C	37,000 h	48,000 h	>72,000 h	>72,000 h	>72,000 h	>72,000 h
	75 °C	36,000 h	46,000 h	>72,000 h	>72,000 h	>72,000 h	>72,000 h
	80 °C	35,000 h	45,000 h	>72,000 h	>72,000 h	>72,000 h	>72,000 h
	85 °C	34,000 h	44,000 h	70,000 h	>72,000 h	>72,000 h	>72,000 h

Forward current	tp tempera- ture	L90 / F10	L90 / F50	L80 / F10	L80 / F50	L70 / F10	L70 / F50
375 mA	45 °C	41,000 h	55,000 h	>72,000 h	>72,000 h	>72,000 h	>72,000 h
	50 °C	40,000 h	54,000 h	>72,000 h	>72,000 h	>72,000 h	>72,000 h
	55 °C	39,000 h	52,000 h	>72,000 h	>72,000 h	>72,000 h	>72,000 h
	60 °C	38,000 h	50,000 h	>72,000 h	>72,000 h	>72,000 h	>72,000 h
	65 °C	37,000 h	49,000 h	>72,000 h	>72,000 h	>72,000 h	>72,000 h
	70 °C	37,000 h	47,000 h	>72,000 h	>72,000 h	>72,000 h	>72,000 h
	75 °C	36,000 h	46,000 h	>72,000 h	>72,000 h	>72,000 h	>72,000 h
	80 °C	35,000 h	44,000 h	71,000 h	>72,000 h	>72,000 h	>72,000 h
	85 °C	34,000 h	43,000 h	69,000 h	>72,000 h	>72,000 h	>72,000 h
	450 mA	40 °C	42,000 h	56,000 h	>72,000 h	>72,000 h	>72,000 h
45 °C		41,000 h	55,000 h	>72,000 h	>72,000 h	>72,000 h	>72,000 h
50 °C		40,000 h	53,000 h	>72,000 h	>72,000 h	>72,000 h	>72,000 h
55 °C		39,000 h	51,000 h	>72,000 h	>72,000 h	>72,000 h	>72,000 h
60 °C		38,000 h	50,000 h	>72,000 h	>72,000 h	>72,000 h	>72,000 h
65 °C		37,000 h	48,000 h	>72,000 h	>72,000 h	>72,000 h	>72,000 h
70 °C		36,000 h	47,000 h	>72,000 h	>72,000 h	>72,000 h	>72,000 h
75 °C		35,000 h	45,000 h	>72,000 h	>72,000 h	>72,000 h	>72,000 h
80 °C		35,000 h	44,000 h	70,000 h	>72,000 h	>72,000 h	>72,000 h
85 °C		34,000 h	43,000 h	69,000 h	>72,000 h	>72,000 h	>72,000 h
500 mA	40 °C	41,000 h	56,000 h	>72,000 h	>72,000 h	>72,000 h	>72,000 h
	45 °C	40,000 h	54,000 h	>72,000 h	>72,000 h	>72,000 h	>72,000 h
	50 °C	39,000 h	52,000 h	>72,000 h	>72,000 h	>72,000 h	>72,000 h
	55 °C	38,000 h	51,000 h	>72,000 h	>72,000 h	>72,000 h	>72,000 h
	60 °C	38,000 h	49,000 h	>72,000 h	>72,000 h	>72,000 h	>72,000 h
	65 °C	37,000 h	48,000 h	>72,000 h	>72,000 h	>72,000 h	>72,000 h
	70 °C	36,000 h	46,000 h	>72,000 h	>72,000 h	>72,000 h	>72,000 h
	75 °C	35,000 h	45,000 h	71,000 h	>72,000 h	>72,000 h	>72,000 h
	80 °C	34,000 h	43,000 h	70,000 h	>72,000 h	>72,000 h	>72,000 h
	85 °C	34,000 h	42,000 h	68,000 h	>72,000 h	>72,000 h	>72,000 h

### 4.3 Switching capability

100,000 cycles

Tridonic test according to IEC 62717 Cl 10.3.3

30 s on / 30 s off at I<sub>max</sub>

## 5. Electrical values

### 5.1 Declaration of electrical parameters

I<sub>rated</sub> ... Nominal operating current the module is designed for.

I<sub>max</sub> ... Max. permissible continuous operating current incl. The tolerances of the LED driver.

Max. permissible LF current ripple ... Max. output current of the LED driver incl. Tolerances and LF current ripple must not exceed this value.

Max. permissible peak current ... The max. output peak current of the LED driver must not exceed this value.

### 5.2 Typ. forward voltage vs. forward current

**LLE 24x70mm 325lm 9xx HV ADV5**

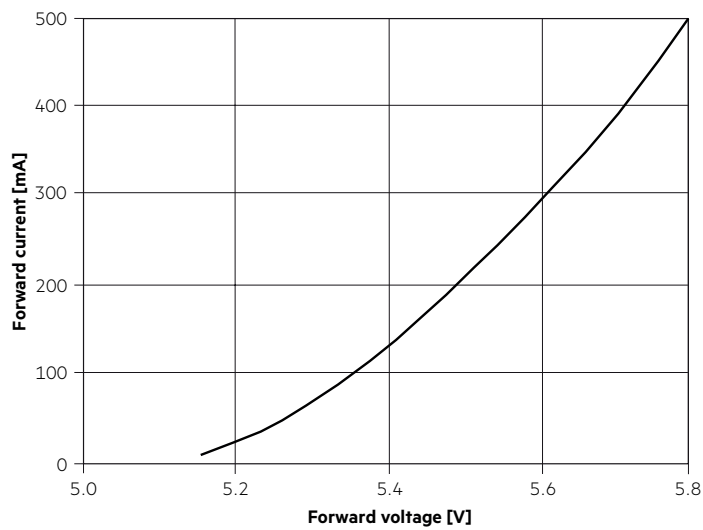

**LLE 24x140mm 650lm 9xx HV ADV5**

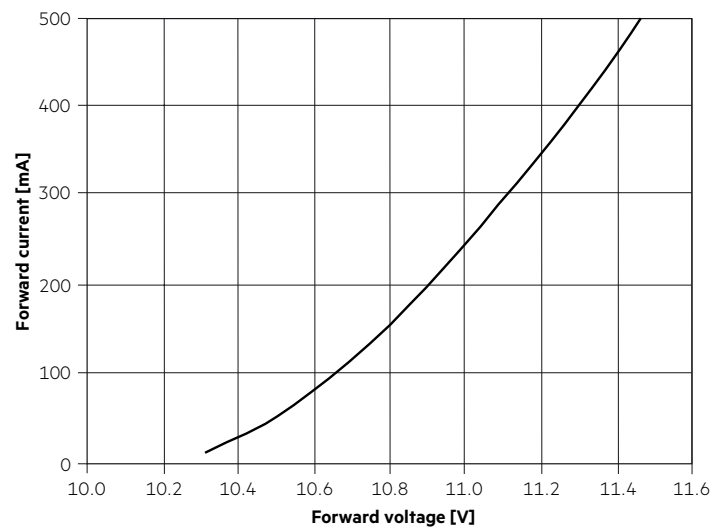

**LLE 24x280mm 1250lm 9xx HV ADV5**

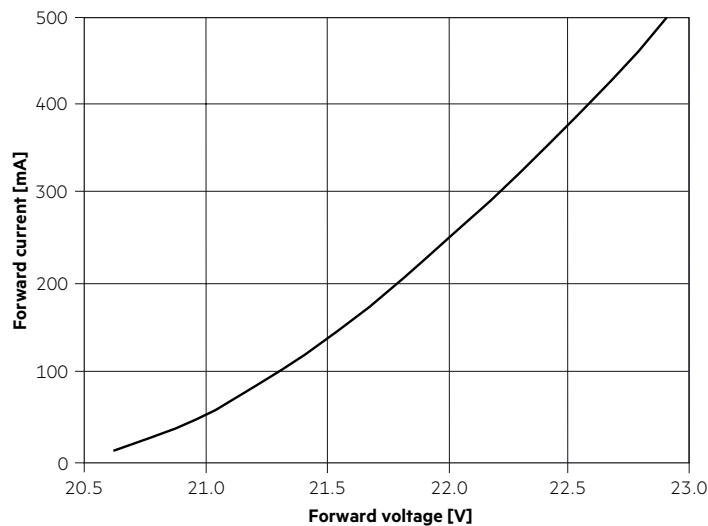

**LLE 24x560mm 2400lm 9xx HV ADV5**

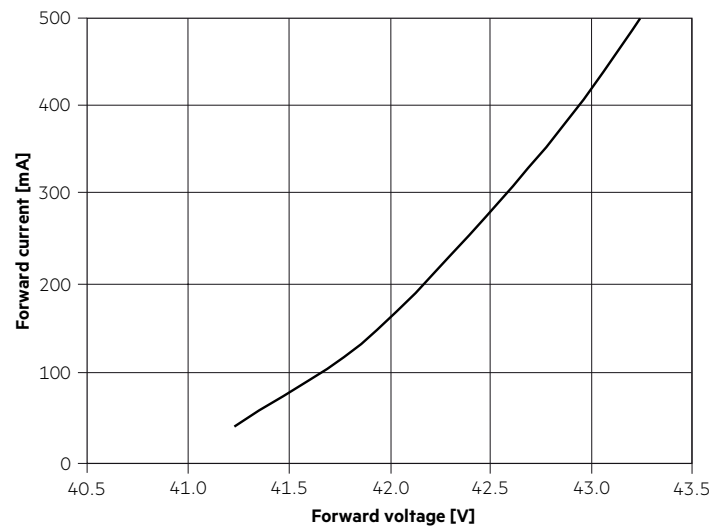

The diagrams are based on statistic values.  
The real values can be different.

### 5.3 Forward voltage vs. tc temperature

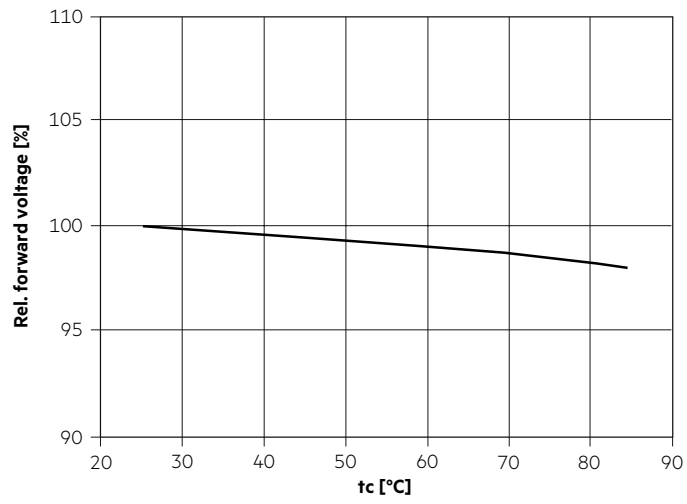



## 6. Photometric characteristics

### 6.1 Coordinates and tolerances according to CIE 1931

The specified colour coordinates are integral measured by current impulse of 195 mA and a duration of 100 ms.  
 The ambient temperature of the measurement is  $t_a = 25^\circ\text{C}$ .  
 The measurement tolerance of the colour coordinates are  $\pm 0.01$ .

2,700 K

	x0	y0
Centre	0.4578	0.4101

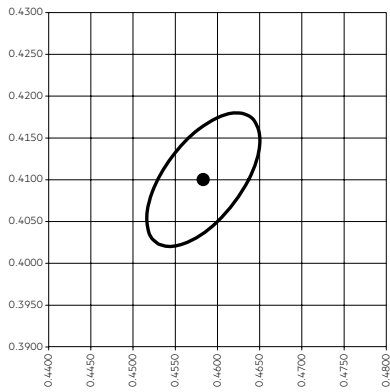

— MacAdam Ellipse: 3SDCM

TM30		CRI	
Rf	Rg	Ra	R9
91	99	93	57

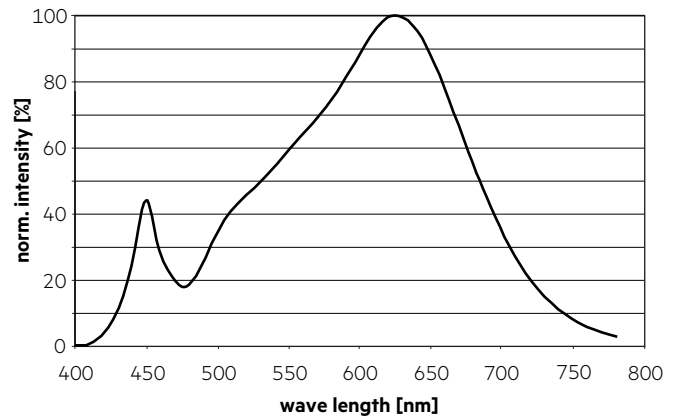

Colour vector graphic

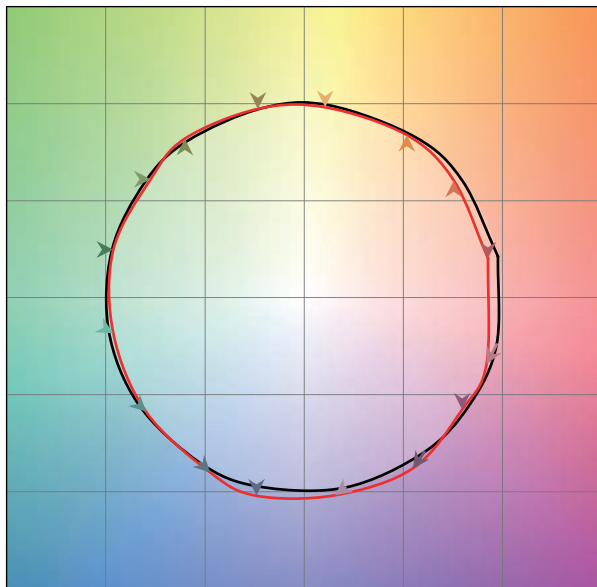

— Reference source  
 — Test source

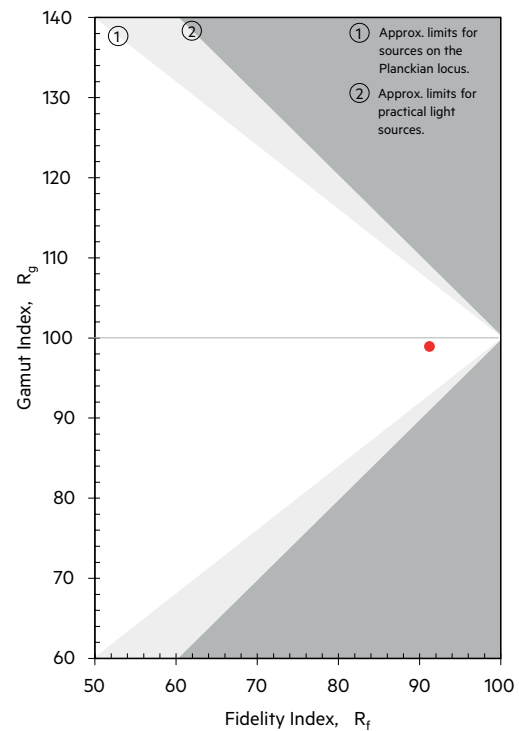

3,000 K

	x0	y0
Centre	0.4338	0.4030

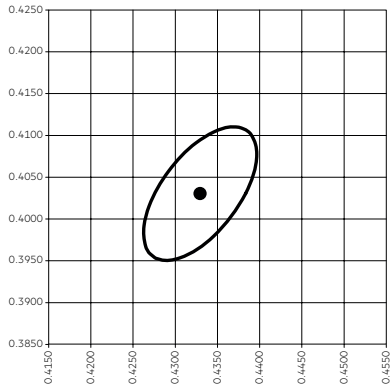

— MacAdam Ellipse: 3SDCM

TM30		CRI	
Rf	Rg	Ra	R9
90	98	92	57

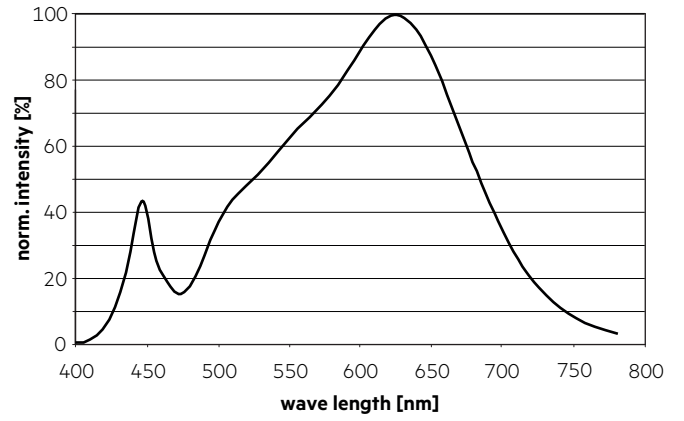

Colour vector graphic

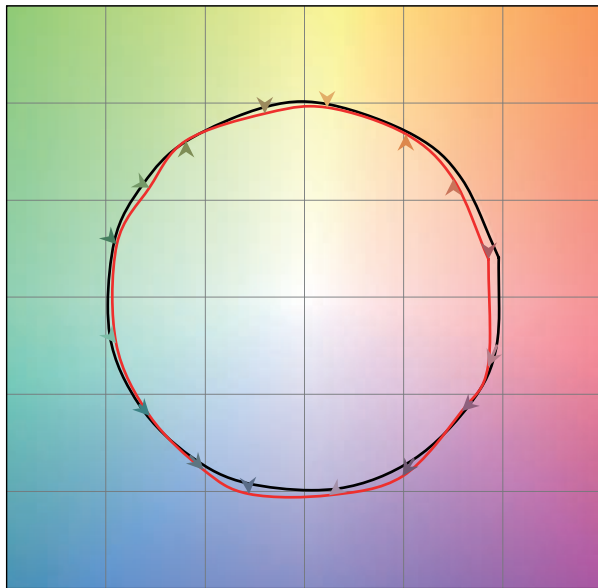

— Reference source  
— Test source

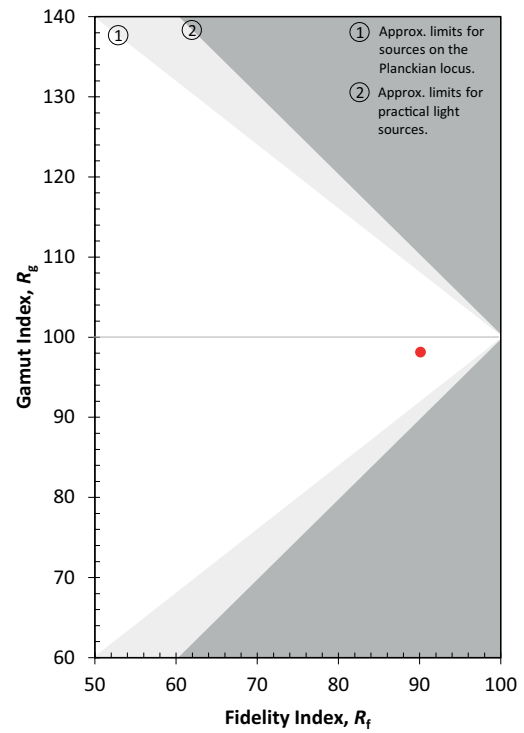

3,500 K

	x0	y0
Centre	0.4073	0.3917

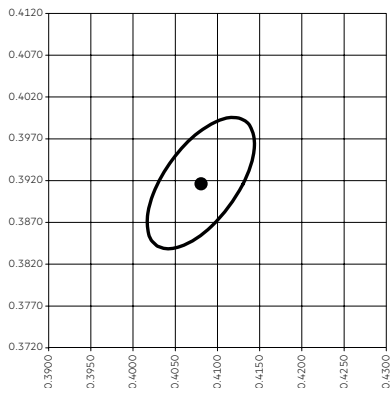

— MacAdam Ellipse: 3SDCM

TM30		CRI	
Rf	Rg	Ra	R9
90	99	93	63

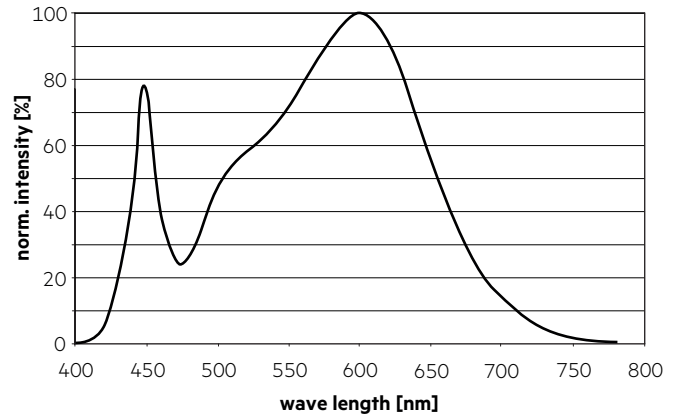

Colour vector graphic

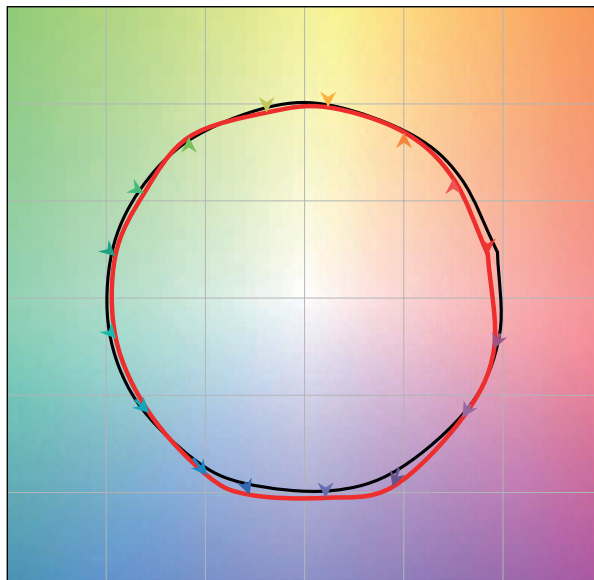

— Reference source  
— Test source

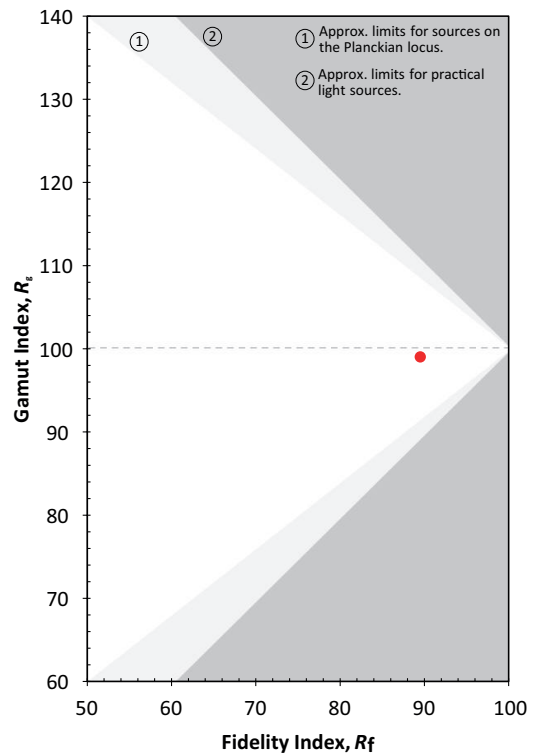

4,000 K

	x0	y0
Center	0.3818	0.3797

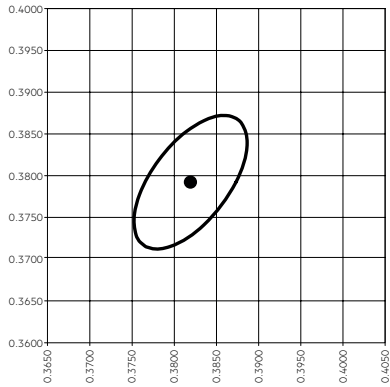

— MacAdam Ellipse: 3SDCM

TM30		CRI	
Rf	Rg	Ra	R9
89	99	91	54

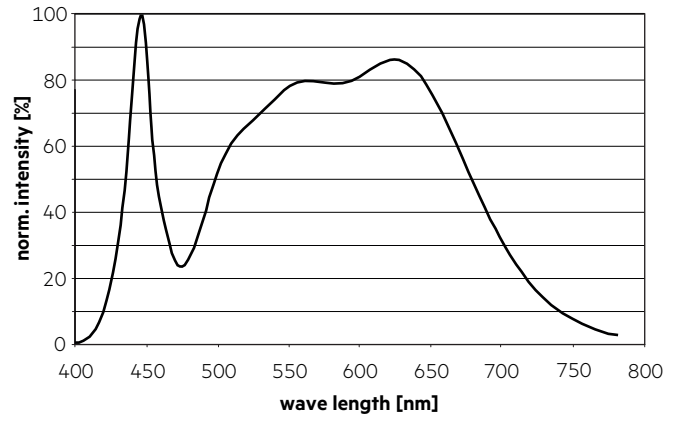

Colour vector graphic

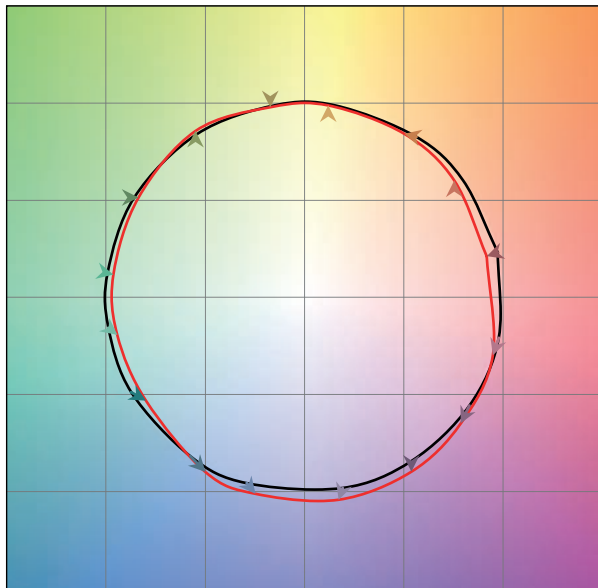

— Reference source  
— Test source

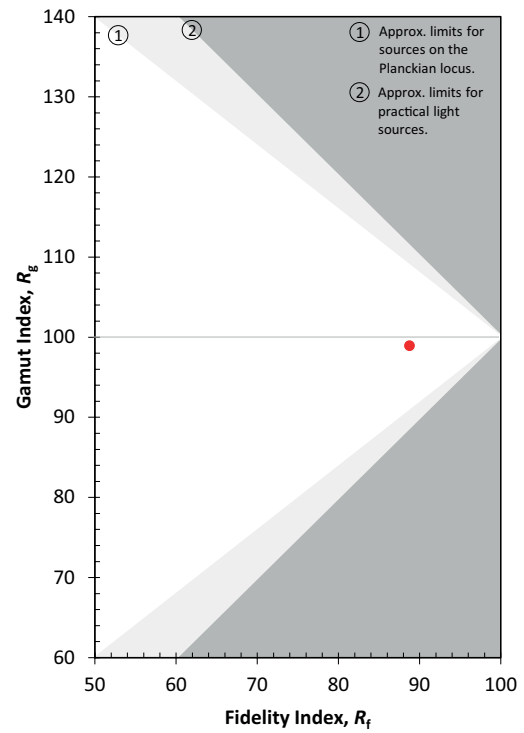

## 6.2 Light distribution

The optical design of the LLE product line ensures optimum homogeneity for the light distribution.

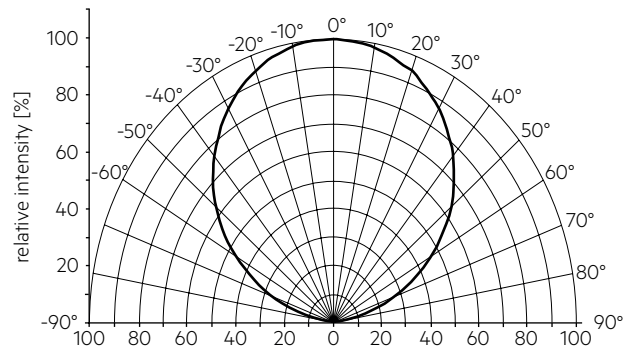

The colour temperature is measured integral over the complete module. The single LED light points can have deviations in the colour coordinates within MacAdam 5.

To ensure an ideal mixture of colours and a homogeneous light distribution a suitable optic (e. g. PMMA diffuser) and a sufficient spacing between module and optic (typ. 4 cm) should be used.

## 6.3 Relative luminous flux vs. tc temperature

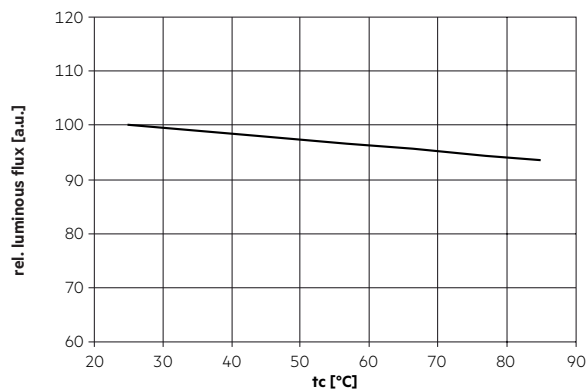

## 6.4 Relative luminous flux vs. operating current

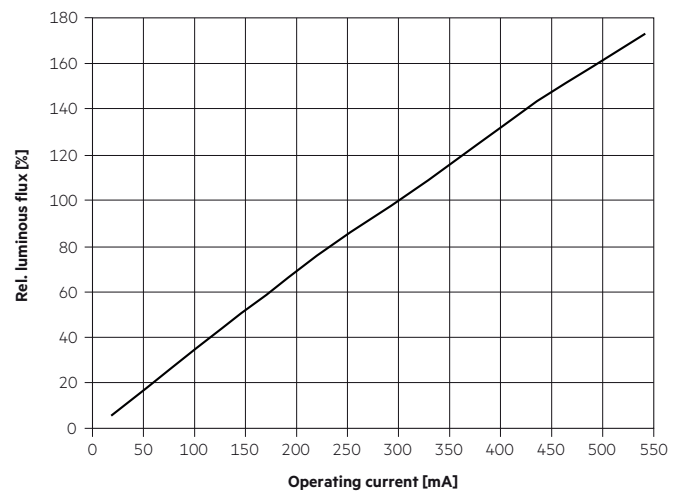

The diagrams are based on statistic values.  
The real values can be different.

## 7. Miscellaneous

### 7.1 Additional information

Additional technical information at [www.tridonic.com](http://www.tridonic.com) → Technical Data

Guarantee conditions at [www.tridonic.com](http://www.tridonic.com) → Services

Lifetime declarations are informative and represent no warranty claim.