

Module LLE 24mm 1100lm CRI80 LV PRE3

Modules LLE premium

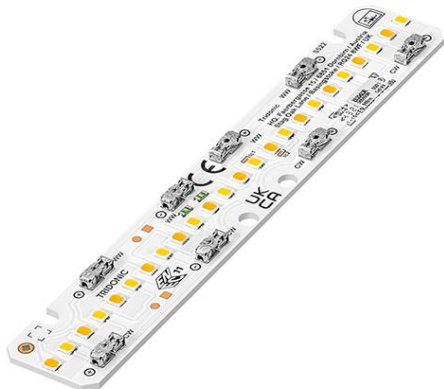

LLE 24x140mm 550lm 827-865 LV PRE3



LLE 24x280mm 1100lm 827-865 LV PRE3



LLE 24x560mm 2200lm 827-865 LV PRE3

Product description

- _ Ideal for linear and panel lights
- _ Optimal solution for Tunable White applications together with LCA PRE DT8 or 2 channel low profile LED drivers
- _ SELV module – the single module has a forward voltage < 60 V
- _ Push terminals for quick and simple wiring
- _ Excellent thermal management
- _ HE ... High Efficiency, NM ... Nominal Mode, HO ... High Output
- _ Long lifetime up to 72,000 hours
- _ 5 years guarantee (conditions at <https://www.tridonic.com/en/int/services/manufacturer-guarantee-conditions>)

Optical properties

- _ Linear Tunable White LED module with 2,700 and 6,500 K SMT packages
- _ Luminous flux 1,110 lm at 6,500 K, Irated and tp = 50 °C
- _ Efficacy of the LED module 188 lm/W at 6,500 K, Irated and tp = 50 °C
- _ High colour rendering index CRI > 80
- _ Small colour tolerance (MacAdam 3) ^①
- _ Low tolerances for luminous flux

Mechanical properties

- _ Module dimension 24 x 140 mm, 24 x 280 mm and 24 x 560 mm (ZHAGA compliant)
- _ Simple installation (e.g ACL push fix)

^① Integral measurement over the complete module.

Website

<http://www.tridonic.com/28004238>



Linear



High bay



Decorative



Downlights



Spotlights



Free-standing



Area



Floor | Wall



Street

Module LLE 24mm 1100lm CRI80 LV PRE3

Modules LLE premium

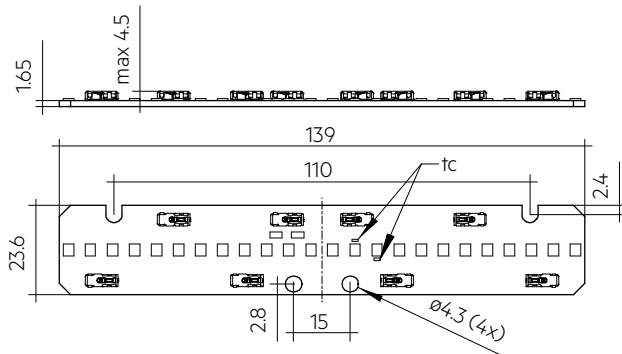

LLE 24x140mm 550lm 827-865 LV PRE3

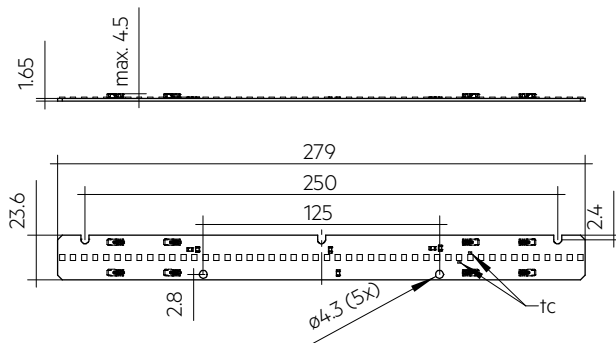

LLE 24x280mm 1100lm 827-865 LV PRE3

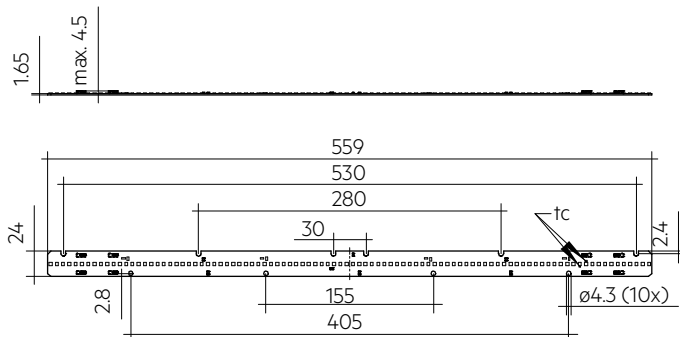

LLE 24x560mm 2200lm 827-865 LV PRE3

Ordering data

Type	Article number	Colour temperature	Packaging, carton	Weight per pc.
LLE 24x140mm 550lm 827-865 LV PRE3	28004238	2,700 – 6,500 K	108 pc(s).	0.012 kg
LLE 24x280mm 1100lm 827-865 LV PRE3	28004239	2,700 – 6,500 K	108 pc(s).	0.023 kg
LLE 24x560mm 2200lm 827-865 LV PRE3	28004240	2,700 – 6,500 K	108 pc(s).	0.045 kg

Technical data

Beam characteristic	120°
Ambient temperature t_a	-25 ... +55 °C
t_p rated	50 °C
t_c	85 °C
I _{rated} for 550 lm	90 mA
I _{rated} for 1,100 lm	180 mA
I _{rated} for 2,200 lm	360 mA
I _{max} for 550 lm	200 mA
I _{max} for 1,100 lm	400 mA
I _{max} for 2,200 lm	800 mA
Max. permissible LF current ripple for 550 lm	250 mA
Max. permissible LF current ripple for 1,100 lm	500 mA
Max. permissible LF current ripple for 2,200 lm	1,000 mA
Max. permissible peak current for 550 lm	450 mA / max. 10 ms
Max. permissible peak current for 1,100 lm	900 mA / max. 10 ms
Max. permissible peak current for 2,200 lm	1,800 mA / max. 10 ms
Max. working voltage for insulation SELV [®]	< 60 V
Insulation test voltage	0.5 kV
CTI of the printed circuit board	≥ 600
ESD classification	Severity level 1
Risk group (IEC 62471)	RG1
Classification acc. to IEC 62031	Built-in
Type of protection	IP00
Lumen maintenance L70B50	72,000 h
Guarantee (conditions at www.tridonic.com)	5 Year(s)

Approval marks**Standards**

EN 62031, EN 62471, EN 61347-1, EN 61547, EN 61000-4-6

Specific technical data

Type	Article number	Colour temperature	Photometric code	Useful luminous flux at tp = 25 °C	Expected luminous flux at tp rated	Typ. forward current	Min. forward voltage at tp rated	Max. forward voltage at tp = 25 °C	Power consumption Pon at tp = 25 °C	Efficacy of the module at tp = 25 °C	Expected efficacy of the module at tp rated	Colour rendering index CRI
Operating mode HE at 100 mA per feet (280 mm module length)												
LLE 24x140mm 550lm 827-865 LV PRE3	28004238	2,700 K	827/359	-	293 lm	50 mA	30.3 V	33.6 V	-	-	183 lm/W	>80
LLE 24x140mm 550lm 827-865 LV PRE3	28004238	3,000 K	830/359	-	300 lm	50 mA	30.3 V	33.6 V	-	-	187 lm/W	>80
LLE 24x140mm 550lm 827-865 LV PRE3	28004238	3,500 K	835/359	-	305 lm	50 mA	30.3 V	33.6 V	-	-	191 lm/W	>80
LLE 24x140mm 550lm 827-865 LV PRE3	28004238	4,000 K	840/359	-	310 lm	50 mA	30.3 V	33.6 V	-	-	194 lm/W	>80
LLE 24x140mm 550lm 827-865 LV PRE3	28004238	5,000 K	850/359	-	312 lm	50 mA	30.3 V	33.6 V	-	-	195 lm/W	>80
LLE 24x140mm 550lm 827-865 LV PRE3	28004238	6,500 K	865/359	-	315 lm	50 mA	30.3 V	33.6 V	-	-	197 lm/W	>80
LLE 24x280mm 1100lm 827-865 LV PRE3	28004239	2,700 K	827/359	-	586 lm	100 mA	30.3 V	33.6 V	-	-	183 lm/W	>80
LLE 24x280mm 1100lm 827-865 LV PRE3	28004239	3,000 K	830/359	-	600 lm	100 mA	30.3 V	33.6 V	-	-	187 lm/W	>80
LLE 24x280mm 1100lm 827-865 LV PRE3	28004239	3,500 K	835/359	-	610 lm	100 mA	30.3 V	33.6 V	-	-	191 lm/W	>80
LLE 24x280mm 1100lm 827-865 LV PRE3	28004239	4,000 K	840/359	-	620 lm	100 mA	30.3 V	33.6 V	-	-	194 lm/W	>80
LLE 24x280mm 1100lm 827-865 LV PRE3	28004239	5,000 K	850/359	-	624 lm	100 mA	30.3 V	33.6 V	-	-	195 lm/W	>80
LLE 24x280mm 1100lm 827-865 LV PRE3	28004239	6,500 K	865/359	-	630 lm	100 mA	30.3 V	33.6 V	-	-	197 lm/W	>80
LLE 24x560mm 2200lm 827-865 LV PRE3	28004240	2,700 K	827/359	-	1,172 lm	200 mA	30.3 V	33.6 V	-	-	183 lm/W	>80
LLE 24x560mm 2200lm 827-865 LV PRE3	28004240	3,000 K	830/359	-	1,200 lm	200 mA	30.3 V	33.6 V	-	-	187 lm/W	>80
LLE 24x560mm 2200lm 827-865 LV PRE3	28004240	3,500 K	835/359	-	1,220 lm	200 mA	30.3 V	33.6 V	-	-	191 lm/W	>80
LLE 24x560mm 2200lm 827-865 LV PRE3	28004240	4,000 K	840/359	-	1,240 lm	200 mA	30.3 V	33.6 V	-	-	194 lm/W	>80
LLE 24x560mm 2200lm 827-865 LV PRE3	28004240	5,000 K	850/359	-	1,248 lm	200 mA	30.3 V	33.6 V	-	-	195 lm/W	>80
LLE 24x560mm 2200lm 827-865 LV PRE3	28004240	6,500 K	865/359	-	1,260 lm	200 mA	30.3 V	33.6 V	-	-	197 lm/W	>80
Operating mode NM at 180 mA per feet (280 mm module length)												
LLE 24x140mm 550lm 827-865 LV PRE3	28004238	2,700 K	827/359	537 lm	515 lm	90 mA	31.0 V	34.3 V	3.0 W	181 lm/W	175 lm/W	>80
LLE 24x140mm 550lm 827-865 LV PRE3	28004238	3,000 K	830/359	-	528 lm	90 mA	31.0 V	34.3 V	-	-	179 lm/W	>80
LLE 24x140mm 550lm 827-865 LV PRE3	28004238	3,500 K	835/359	-	540 lm	90 mA	31.0 V	34.3 V	-	-	183 lm/W	>80
LLE 24x140mm 550lm 827-865 LV PRE3	28004238	4,000 K	840/359	-	550 lm	90 mA	31.0 V	34.3 V	-	-	187 lm/W	>80
LLE 24x140mm 550lm 827-865 LV PRE3	28004238	5,000 K	850/359	-	552 lm	90 mA	31.0 V	34.3 V	-	-	187 lm/W	>80
LLE 24x140mm 550lm 827-865 LV PRE3	28004238	6,500 K	865/359	-	555 lm	90 mA	31.0 V	34.3 V	-	-	188 lm/W	>80
LLE 24x280mm 1100lm 827-865 LV PRE3	28004239	2,700 K	827/359	1,074 lm	1,030 lm	180 mA	31.0 V	34.3 V	5.9 W	181 lm/W	175 lm/W	>80
LLE 24x280mm 1100lm 827-865 LV PRE3	28004239	3,000 K	830/359	-	1,056 lm	180 mA	31.0 V	34.3 V	-	-	179 lm/W	>80
LLE 24x280mm 1100lm 827-865 LV PRE3	28004239	3,500 K	835/359	-	1,080 lm	180 mA	31.0 V	34.3 V	-	-	183 lm/W	>80
LLE 24x280mm 1100lm 827-865 LV PRE3	28004239	4,000 K	840/359	-	1,100 lm	180 mA	31.0 V	34.3 V	-	-	187 lm/W	>80
LLE 24x280mm 1100lm 827-865 LV PRE3	28004239	5,000 K	850/359	-	1,104 lm	180 mA	31.0 V	34.3 V	-	-	187 lm/W	>80
LLE 24x280mm 1100lm 827-865 LV PRE3	28004239	6,500 K	865/359	-	1,110 lm	180 mA	31.0 V	34.3 V	-	-	188 lm/W	>80
LLE 24x560mm 2200lm 827-865 LV PRE3	28004240	2,700 K	827/359	2,148 lm	2,060 lm	360 mA	31.0 V	34.3 V	11.8 W	181 lm/W	175 lm/W	>80
LLE 24x560mm 2200lm 827-865 LV PRE3	28004240	3,000 K	830/359	-	2,112 lm	360 mA	31.0 V	34.3 V	-	-	179 lm/W	>80
LLE 24x560mm 2200lm 827-865 LV PRE3	28004240	3,500 K	835/359	-	2,160 lm	360 mA	31.0 V	34.3 V	-	-	183 lm/W	>80
LLE 24x560mm 2200lm 827-865 LV PRE3	28004240	4,000 K	840/359	-	2,200 lm	360 mA	31.0 V	34.3 V	-	-	187 lm/W	>80
LLE 24x560mm 2200lm 827-865 LV PRE3	28004240	5,000 K	850/359	-	2,208 lm	360 mA	31.0 V	34.3 V	-	-	187 lm/W	>80
LLE 24x560mm 2200lm 827-865 LV PRE3	28004240	6,500 K	865/359	-	2,220 lm	360 mA	31.0 V	34.3 V	-	-	188 lm/W	>80
Operating mode HO at 370 mA per feet (280 mm module length)												
LLE 24x140mm 550lm 827-865 LV PRE3	28004238	2,700 K	827/359	-	1,005 lm	185 mA	32.4 V	35.8 V	-	-	159 lm/W	>80
LLE 24x140mm 550lm 827-865 LV PRE3	28004238	3,000 K	830/359	-	1,050 lm	185 mA	32.4 V	35.8 V	-	-	166 lm/W	>80
LLE 24x140mm 550lm 827-865 LV PRE3	28004238	3,500 K	835/359	-	1,080 lm	185 mA	32.4 V	35.8 V	-	-	171 lm/W	>80
LLE 24x140mm 550lm 827-865 LV PRE3	28004238	4,000 K	840/359	-	1,098 lm	185 mA	32.4 V	35.8 V	-	-	174 lm/W	>80
LLE 24x140mm 550lm 827-865 LV PRE3	28004238	5,000 K	850/359	-	1,108 lm	185 mA	32.4 V	35.8 V	-	-	175 lm/W	>80
LLE 24x140mm 550lm 827-865 LV PRE3	28004238	6,500 K	865/359	-	1,080 lm	185 mA	32.4 V	35.8 V	-	-	171 lm/W	>80
LLE 24x280mm 1100lm 827-865 LV PRE3	28004239	2,700 K	827/359	-	2,010 lm	370 mA	32.4 V	35.8 V	-	-	159 lm/W	>80
LLE 24x280mm 1100lm 827-865 LV PRE3	28004239	3,000 K	830/359	-	2,100 lm	370 mA	32.4 V	35.8 V	-	-	166 lm/W	>80
LLE 24x280mm 1100lm 827-865 LV PRE3	28004239	3,500 K	835/359	-	2,160 lm	370 mA	32.4 V	35.8 V	-	-	171 lm/W	>80
LLE 24x280mm 1100lm 827-865 LV PRE3	28004239	4,000 K	840/359	-	2,196 lm	370 mA	32.4 V	35.8 V	-	-	174 lm/W	>80
LLE 24x280mm 1100lm 827-865 LV PRE3	28004239	5,000 K	850/359	-	2,216 lm	370 mA	32.4 V	35.8 V	-	-	175 lm/W	>80
LLE 24x280mm 1100lm 827-865 LV PRE3	28004239	6,500 K	865/359	-	2,160 lm	370 mA	32.4 V	35.8 V	-	-	171 lm/W	>80
LLE 24x560mm 2200lm 827-865 LV PRE3	28004240	2,700 K	827/359	-	4,020 lm	740 mA	32.4 V	35.8 V	-	-	159 lm/W	>80
LLE 24x560mm 2200lm 827-865 LV PRE3	28004240	3,000 K	830/359	-	4,200 lm	740 mA	32.4 V	35.8 V	-	-	166 lm/W	>80
LLE 24x560mm 2200lm 827-865 LV PRE3	28004240	3,500 K	835/359	-	4,320 lm	740 mA	32.4 V	35.8 V	-	-	171 lm/W	>80
LLE 24x560mm 2200lm 827-865 LV PRE3	28004240	4,000 K	840/359	-	4,392 lm	740 mA	32.4 V	35.8 V	-	-	174 lm/W	>80
LLE 24x560mm 2200lm 827-865 LV PRE3	28004240	5,000 K	850/359	-	4,432 lm	740 mA	32.4 V	35.8 V	-	-	175 lm/W	>80
LLE 24x560mm 2200lm 827-865 LV PRE3	28004240	6,500 K	865/359	-	4,320 lm	740 mA	32.4 V	35.8 V	-	-	171 lm/W	>80

② For details see 3.1 Electrical supply/choice of LED driver in data sheet.

③ Tolerance of useful light flux - 0 % / + 15 %. Measurement uncertainty ± 10 %.

④ Tolerance of expected light flux - 0 % / + 15 %. Measurement uncertainty ± 10 %. Based on calculation.

⑤ Tolerance of power consumption Pon ± 10 %. Measurement uncertainty ± 5 %.

LINEAR COVER LLE

Accessory

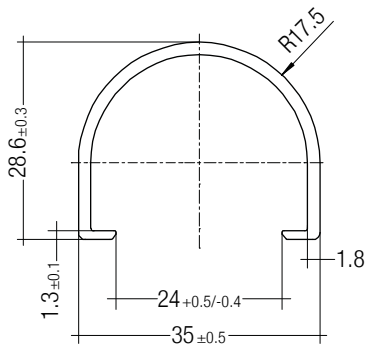

Product description

- _ LINEAR COVER for LLE
- _ Protection against direct touch for non-SELV applications (recommendation LLE 20: use all fixing points and screwed Endcap, recommendation LLE 24: use all fixing points)
- _ Fast snap on mounting on to LLE 20: with M4 screws and plastic washers, to LLE 24: with clips or plastic washers
- _ High transmission: transparent, semi-transparent and diffuse
- _ Material: PMMA
- _ Tolerances: ± 1 mm for 597 mm length (ends finished), + 10 mm from length 1,150 mm (ends raw)

Website

<http://www.tridonic.com/28000338>



Ordering data

Type	Article number	Colour	Length L	Efficiency	Packaging, carton	Weight per pc.
LINEAR COVER SY Transparent 1600mm	28000338	Transparent	1,600 mm	94 %	12 pc(s).	0.272 kg
LINEAR COVER SY Frosted 1800mm	28000437	Semi-transparent	1,800 mm	87 %	12 pc(s).	0.308 kg
LINEAR COVER SY Frosted 1600mm	28000339	Semi-transparent	1,600 mm	87 %	12 pc(s).	0.272 kg
LINEAR COVER SY Frosted 1500mm	28000435	Semi-transparent	1,500 mm	87 %	12 pc(s).	0.244 kg
LINEAR COVER SY Frosted 1200mm	28000422	Semi-transparent	1,200 mm	87 %	12 pc(s).	0.205 kg
LINEAR COVER SY Frosted 597mm	28000340	Semi-transparent	597 mm	87 %	12 pc(s).	0.102 kg
LINEAR COVER SY Diffuse 1800mm	28000438	Diffuse	1,800 mm	76 %	12 pc(s).	0.308 kg
LINEAR COVER SY Diffuse 1600mm	28000341	Diffuse	1,600 mm	76 %	12 pc(s).	0.272 kg
LINEAR COVER SY Diffuse 1500mm	28000436	Diffuse	1,500 mm	76 %	12 pc(s).	0.257 kg
LINEAR COVER SY Diffuse 1200mm	28000434	Diffuse	1,200 mm	76 %	12 pc(s).	0.205 kg
LINEAR COVER SY Diffuse 597mm	28000342	Diffuse	597 mm	76 %	12 pc(s).	0.102 kg

ACL ENDCAP LLE

Accessory



Product description

- _ ENDCAP for LLE
- _ PUSH-FIX: Fast snap on mounting (sheet thickness 0.5 – 1.0 mm), for drilling hole 4 mm
- _ SCREW-FIX: Screw mounting with EJOT Delta PT WN 5451 30x8 (not included), tightening torque 0.7 Nm
- _ Clip made of polycarbonate

Website

<http://www.tridonic.com/28001037>

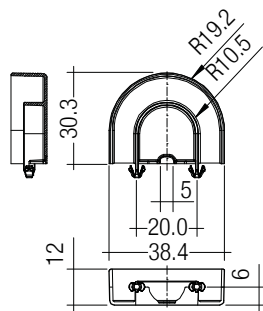

Ordering data

Type	Article number	Colour	Packaging, carton	Weight per pc.
ACL ENDCAP LLE24 PUSH-FIX	28001037	White	480 pc(s).	0.003 kg
ACL ENDCAP LLE24 SCREW-FIX	28002315	White	480 pc(s).	0.003 kg

ACL LINEAR LENS 24mm

Accessory



Product description LINEAR LENS

- _ Linear lens for LLE 20 / 24
- _ Available with different beam characteristics
- _ Protection against direct touch for non-SELV applications (recommendation: use all fixing points)
- _ Fast snap on mounting on to LLE 20: with M4 screws and plastic washers, to LLE 24: with clips or plastic washers
- _ Recommendation: Fastening with screws and plastic washers, see 2.3 Heat sink specifications in data sheet
- _ Material: PMMA
- _ Available lengths: 1,200, 1,500 and 1,800 mm, Tolerance: + 10 mm (ends raw)
- _ Max. permissible temperature 80 °C
- _ Photometric data available on website

Product description Endcap

- _ ENDCAP for LINEAR LENS 24mm INTENSE, ASY and DASY
- _ Mounting by clipping in and screwing from below using screw EJOT Delta PT WN 5451 20x4, tightening torque 0.7 Nm
- _ Made of Polyamide UL94 V0

Website

<http://www.tridonic.com/28001428>

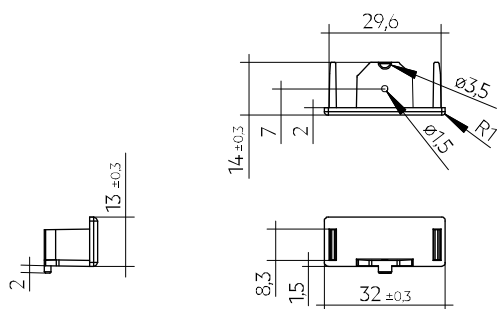

Ordering data

Type	Article number	Length L	Beam characteristic	Efficiency	Packaging, carton	Weight per pc.
ACL LINEAR LENS 24x1200mm 60°	28001428	1,200 mm	60°	97 %	21 pc(s).	0.196 kg
ACL LINEAR LENS 24x1200mm 90°	28001429	1,200 mm	90°	97 %	21 pc(s).	0.165 kg
ACL LINEAR LENS 24x1500mm 60°	28000953	1,500 mm	60°	97 %	21 pc(s).	0.261 kg
ACL LINEAR LENS 24x1500mm 90°	28000955	1,500 mm	90°	97 %	21 pc(s).	0.221 kg
ACL LINEAR LENS 24x1200mm INTENSE	28002024	1,200 mm	40°	95 %	18 pc(s).	0.261 kg
ACL LINEAR LENS 24x1500mm INTENSE	28002025	1,500 mm	40°	95 %	18 pc(s).	0.326 kg
ACL LINEAR LENS 24x1800mm INTENSE	28002026	1,800 mm	40°	95 %	18 pc(s).	0.392 kg
ACL LINEAR LENS 24x1200mm BATWING	28002027	1,200 mm	batwing	95 %	18 pc(s).	0.275 kg
ACL LINEAR LENS 24x1500mm BATWING	28002028	1,500 mm	batwing	95 %	18 pc(s).	0.344 kg
ACL LINEAR LENS 24x1800mm BATWING	28002029	1,800 mm	batwing	95 %	18 pc(s).	0.412 kg
ACL LINEAR LENS 24x1200mm ASY	28002030	1,200 mm	asymmetric	95 %	18 pc(s).	0.250 kg
ACL LINEAR LENS 24x1500mm ASY	28002031	1,500 mm	asymmetric	95 %	18 pc(s).	0.312 kg
ACL LINEAR LENS 24x1800mm ASY	28002032	1,800 mm	asymmetric	95 %	18 pc(s).	0.375 kg
ACL LINEAR LENS 24x1200mm DASY	28002033	1,200 mm	double asymmetric	92 %	18 pc(s).	0.249 kg
ACL LINEAR LENS 24x1500mm DASY	28002034	1,500 mm	double asymmetric	92 %	18 pc(s).	0.311 kg
ACL LINEAR LENS 24x1800mm DASY	28002035	1,800 mm	double asymmetric	92 %	18 pc(s).	0.373 kg
ACL Endcap LENS 24mm PSF	28002669	-	-	-	3,600 pc(s).	0.003 kg

ACL CLIP 4.3mm

Accessory



Product description

- _ Clip for fixation of LED modules with 4.3 mm holes
- _ Fast snap on mounting (sheet thickness 0.5 – 1.0 mm for PUSH-FIX and 1 – 2 mm for PUSH-FIX Long)
- _ For drilling hole 4 mm
- _ Clip made of polycarbonate
- _ Minimum sales quantity 500 pcs.

Website

<http://www.tridonic.com/28001036>

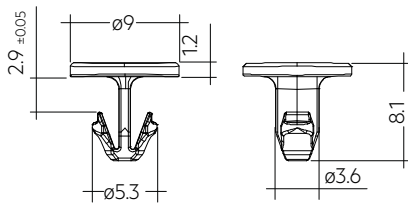

Ordering data

Type	Article number	Colour	Packaging, bag ^①	Weight per pc.
ACL CLIP 4.3mm PUSH-FIX	28001036	White	500 pc(s).	0.001 kg
ACL CLIP 4,3mm PUSH-FIX Long	28002314	Transparent	500 pc(s).	0.001 kg

① Minimum sales quantity 500 pcs.

1. Standards

EN 62031
EN 62471
EN 61347-1
EN 61547
EN 61000-4-6

1.1 Photometric code

Key for photometric code, e. g. 930 / 349

1 st digit	2 nd + 3 rd digit	4 th digit	5 th digit	6 th digit	
Code CRI	Colour temperature in Kelvin x 100	McAdam initial	McAdam after 25% of the lifetime (max.6000h)	Luminous flux after 25% of the lifetime (max.6000h)	
7 70 – 79				Code	Luminous flux
8 80 – 89				7	≥ 70 %
9 ≥90				8	≥ 80 %
				9	≥ 90 %

1.2 Energy classification

Type	Colour temperature	Forward current	Energy classification	Energy consumption
LLE 24x140mm 550lm 827-865 LV PRE3	2,700 K	90 mA	C	3 kWh / 1,000 h
LLE 24x280mm 1100lm 827-865 LV PRE3	2,700 K	180 mA	C	6 kWh / 1,000 h
LLE 24x560mm 2200lm 827-865 LV PRE3	2,700 K	360 mA	C	12 kWh / 1,000 h

Energy label and further information at www.tridonic.com in the certificates tab of the corresponding product page and at the EPREL data base <https://eprel.ec.europa.eu/>

2. Thermal details

2.1 tc point, ambient temperature and lifetime

The temperature at tp reference point is crucial for the light output and lifetime of a LED product.

For LLE a tp temperature of 50 °C has to be complied in order to achieve an optimum between heat sink requirements, light output and lifetime.

Compliance with the maximum permissible reference temperature at the tc point must be checked under operating conditions in a thermally stable state. The maximum value must be determined under worst-case conditions for the relevant application.

The tc and tp temperature of LED modules from Tridonic are measured at the same reference point.

2.2 Storage and humidity

Storage temperature	-40 ... +80 °C
---------------------	----------------

Operation only in non condensing environment.
Humidity during processing of the module should be between 30 to 70 %.

2.3 Thermal design and heat sink

The rated life of LED products depends to a large extent on the temperature. If the permissible temperature limits are exceeded, the life of the LLE will be greatly reduced or the LLE may be destroyed.

Therefore the LLE needs to be mounted onto a heat sink.

Tridonic's excellent thermal design for the LED products provides the lowest thermal resistance and therefore allowing new compact designs without sacrificing quality, safety and lifetime.

2.4 Heat sink values

LLE 24x140mm 550lm 827-865 LV PRE3

ta	tp	Forward current	R _{th, hs-a}	Cooling area
25 °C	50 °C	90 mA	15.55 K/W	43 cm ²
35 °C	50 °C	90 mA	8.76 K/W	76 cm ²
40 °C	50 °C	90 mA	5.36 K/W	124 cm ²
45 °C	50 °C	90 mA	1.97 K/W	339 cm ²

LLE 24x280mm 1100lm 827-865 LV PRE3

ta	tp	Forward current	R _{th, hs-a}	Cooling area
25 °C	50 °C	180 mA	7.86 K/W	85 cm ²
35 °C	50 °C	180 mA	4.43 K/W	151 cm ²
40 °C	50 °C	180 mA	2.71 K/W	246 cm ²
45 °C	50 °C	180 mA	1.00 K/W	667 cm ²

LLE 24x560mm 2200lm 827-865 LV PRE3

ta	tp	Forward current	R _{th, hs-a}	Cooling area
25 °C	50 °C	360 mA	3.85 K/W	173 cm ²
35 °C	50 °C	360 mA	2.17 K/W	308 cm ²
40 °C	50 °C	360 mA	1.33 K/W	503 cm ²
45 °C	50 °C	360 mA	0.48 K/W	1,377 cm ²

Notes

These values apply to a single LED module.

The actual cooling surface can differ because of the material, the structural shape, outside influences and the installation situation. The LED modules must rest flat on the heat sink.

3. Installation / wiring

3.1 Electrical supply/choice of LED driver

LLE modules from Tridonic are not protected against overvoltages, overcurrents, overloads or short-circuit currents. Safe and reliable operation can only be guaranteed in conjunction with a LED driver which complies with the relevant standards. The use of LED driver from Tridonic in combination with LLE modules guarantees the necessary protection for safe and reliable operation.

If a LED driver other than Tridonic is used, it must provide the following protection:

- Short-circuit protection
- Overload protection
- Overtemperature protection



LLE modules must be supplied by a constant current LED driver. Operation with a constant voltage LED driver will lead to an irreversible damage of the module.

Wrong polarity can damage the LLE.

With parallel wiring tolerance-related differences in output are possible (thermal stress of the module) and can cause differences in brightness.

If a wire breaks or a complete module fails then the current passing through the other module increases. This may reduce its life considerably.

The max. permissible output current of the LED driver for parallel wiring is 3 A.

LLE have to be operated with SELV LED drivers.



LLE are basic insulated up to 60 V SELV (if mounted with M4 screws with head diameter 8 mm) against ground and can be mounted directly on earthed metal parts of the luminaire. If the max. output voltage of the LED driver (also against earth) is above 60 V SELV, an additional insulation between LED module and heat sink is required (for example by insulated thermal pads) or by a suitable luminaire construction.



Protection against accidental contact of live parts and compliance with clearances and creepage distances must be ensured in the final application.

3.2 Wiring

Wiring diagram for switchDIM and colourSWITCH for LLE premium

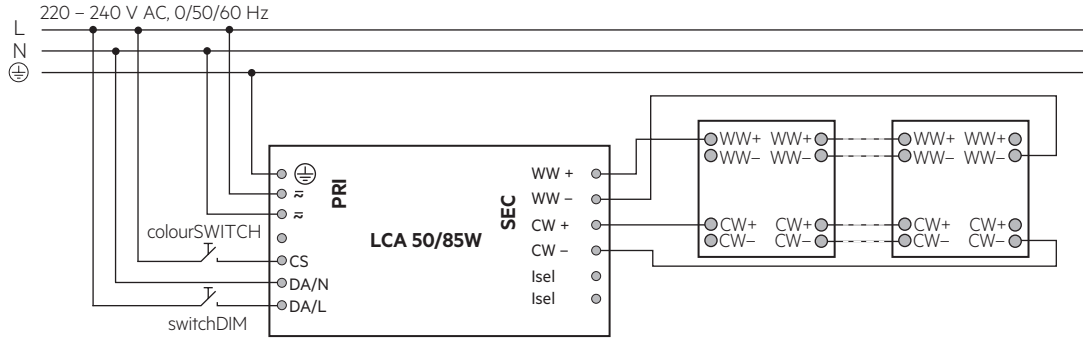

Wiring diagram for DALI for LLE premium

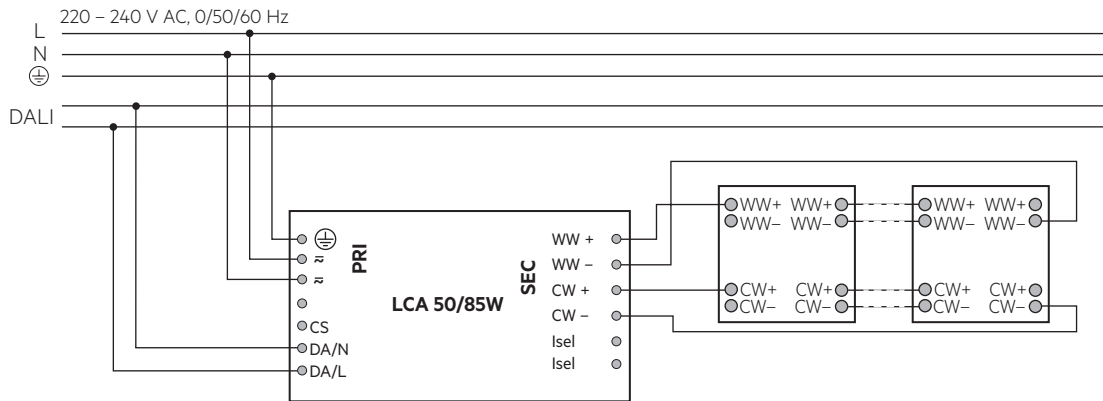

Wiring diagram for switchDIM and colourSWITCH for LLE premium

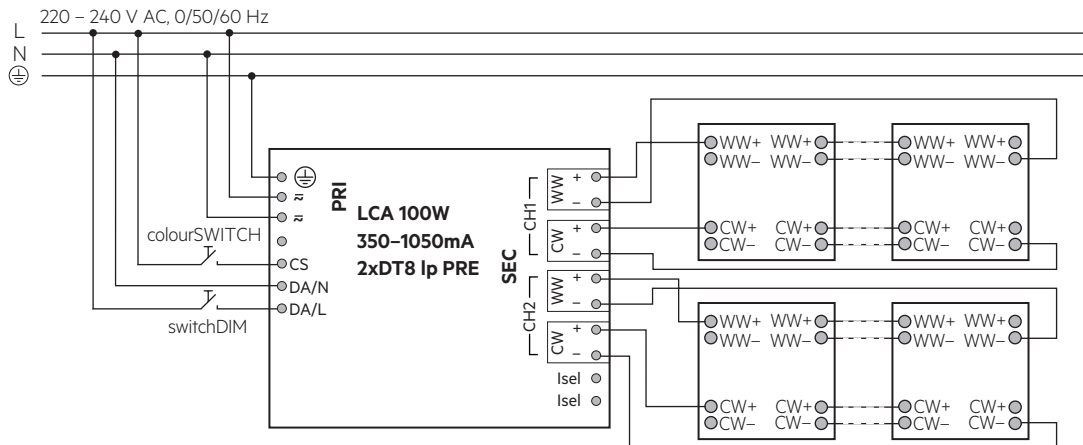

Wiring diagram for DALI for LLE premium

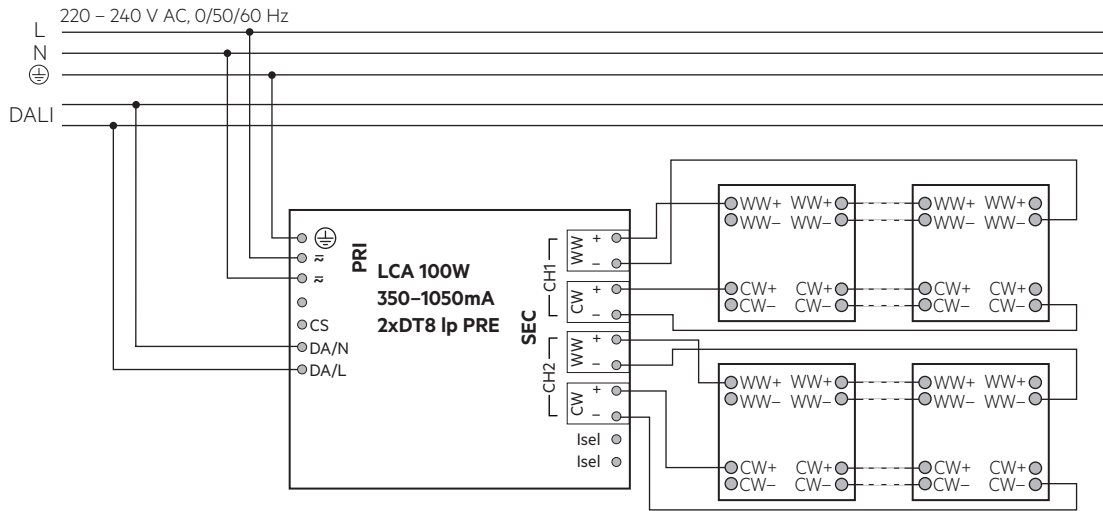

Wiring diagram for emergency

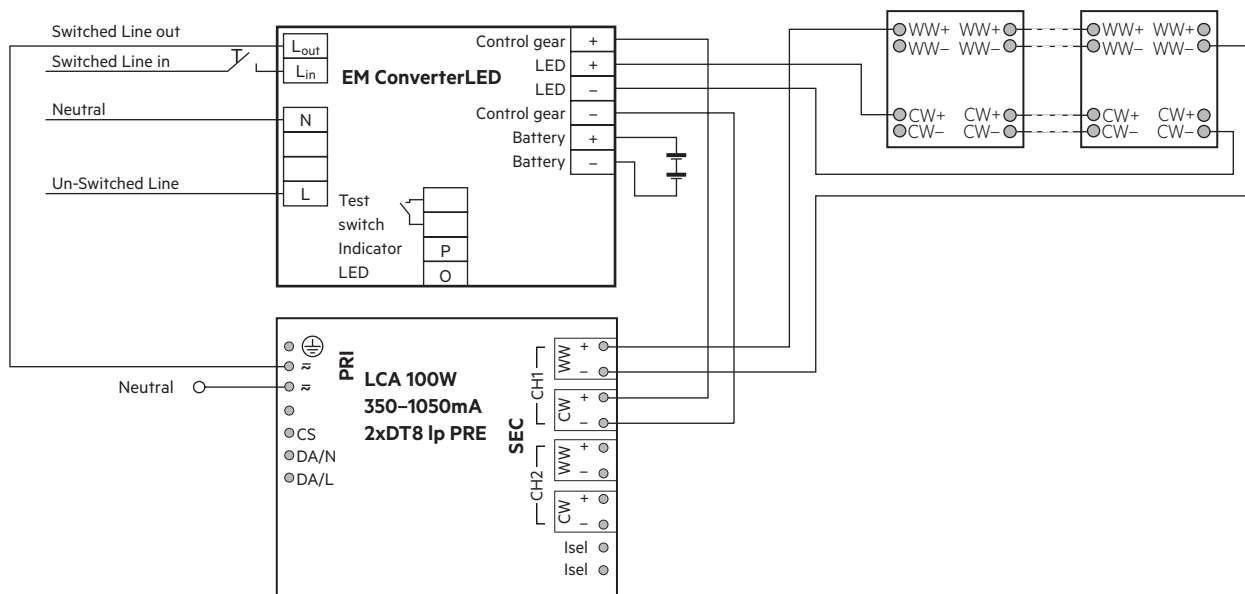

3.3 Wiring type and cross section

For horizontal wiring use stranded wire of 0.5 mm² or solid wire from 0.2 to 0.5 mm² (stripping length 8 - 9 mm) and for vertical wiring solid wire with 0.5 mm² (stripping length > 3 mm).

Only one wire per terminal allowed.

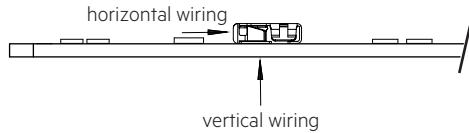

wire preparation (horizontal):
0.2 - 0.5 mm²

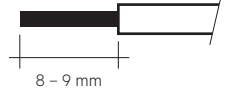

wire preparation (vertical):
0.5 mm²

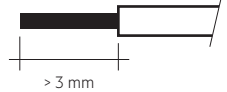

Removing the wires through wrist and pull.

Cut-out for vertical wiring of LLE 24x140mm PRE3:

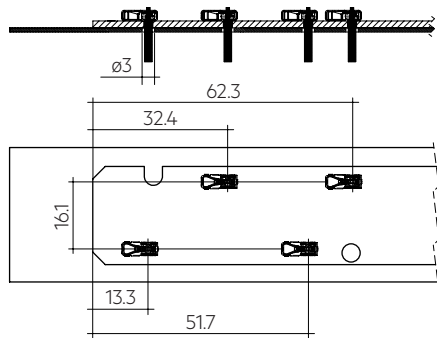

Cut-out for vertical wiring of LLE 24x280mm PRE3 and LLE 24x560mm PRE3:

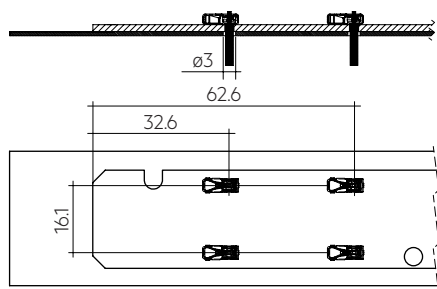

3.4 Mounting instruction



None of the components of the LLE (substrate, LED, electronic components etc.) may be exposed to tensile or compressive stresses.

Max. torque for fixing: 0.5 Nm.

The LED modules are mounted onto a heat sink with min. 3 screws per module or ACL CLIP 4.3mm.



Chemical substance may harm the LED module. Chemical reactions could lead to colour shift, reduced luminous flux or a total failure of the module caused by corrosion of electrical connections.

Materials which are used in LED applications (e.g. sealings, adhesives) must not produce dissolver gas. They must not be condensation curing based, acetate curing based or contain sulfur, chlorine or phthalate.

Avoid corrosive atmosphere during usage and storage.

3.5 EOS/ESD safety guidelines



The device / module contains components that are sensitive to electrostatic discharge and may only be installed in the factory and on site if appropriate EOS/ESD protection measures have been taken. No special measures need be taken for devices/modules with enclosed casings (contact with the pc board not possible), just normal installation practice. Please note the requirements set out in the document EOS / ESD guidelines (Guideline_EOS_ESD.pdf) at: <http://www.tridonic.com/esd-protection>

4. Lifetime

4.1 Lifetime, lumen maintenance and failure rate

The light output of an LED module decreases over the lifetime, this is characterized with the L value.

L70 means that the LED module will have 70 % of its initial luminous flux after the stated operating time. This value is always related to the number of operation hours and therefore defines the lifetime of an LED module.

As the L value is a statistical value the lumen maintenance may vary over the delivered LED modules.

The B value defines the amount of modules which are below the specific L value, e.g. L70B10 means 10 % of the LED modules are below 70 % of the initial luminous flux, respectively 90 % will be above 70 % of the initial value. In addition the percentage of failed modules (fatal failure) is characterized by the C value.

4.2 Lumen maintenance for LLE premium

Lifetime declarations are informative and represent no warranty claim.

Forward current	tp tempera- ture	L90 / B10		L80 / B10		L70 / B10	
		L90 / B10	L90 / B50	L80 / B10	L80 / B50	L70 / B10	L70 / B50
100 mA / ft (280 mm module length)	40 °C	>72k h	>72k h	>72k h	>72k h	>72k h	>72k h
	45 °C	>72k h	>72k h	>72k h	>72k h	>72k h	>72k h
	50 °C	>72k h	>72k h	>72k h	>72k h	>72k h	>72k h
	55 °C	>72k h	>72k h	>72k h	>72k h	>72k h	>72k h
	60 °C	>72k h	>72k h	>72k h	>72k h	>72k h	>72k h
	65 °C	>72k h	>72k h	>72k h	>72k h	>72k h	>72k h
	70 °C	>72k h	>72k h	>72k h	>72k h	>72k h	>72k h
	75 °C	>72k h	>72k h	>72k h	>72k h	>72k h	>72k h
	80 °C	>72k h	>72k h	>72k h	>72k h	>72k h	>72k h
	180 mA / ft (280 mm module length)	40 °C	61k h	>72k h	>72k h	>72k h	>72k h
45 °C		57k h	>72k h	>72k h	>72k h	>72k h	>72k h
50 °C		53k h	71k h	>72k h	>72k h	>72k h	>72k h
55 °C		50 kh	67k h	>72k h	>72k h	>72k h	>72k h
60 °C		46k h	62k h	>72k h	>72k h	>72k h	>72k h
65 °C		43k h	58k h	>72k h	>72k h	>72k h	>72k h
70 °C		40k h	54k h	>72k h	>72k h	>72k h	>72k h
75 °C		38k h	51k h	>72k h	>72k h	>72k h	>72k h
80 °C		35k h	47k h	>72k h	>72k h	>72k h	>72k h
210 mA / ft (280 mm module length)		40 °C	61k h	>72k h	>72k h	>72k h	>72k h
	45 °C	57k h	>72k h	>72k h	>72k h	>72k h	>72k h
	50 °C	53k h	71k h	>72k h	>72k h	>72k h	>72k h
	55 °C	50k h	67k h	>72k h	>72k h	>72k h	>72k h
	60 °C	46k h	62k h	>72k h	>72k h	>72k h	>72k h
	65 °C	43k h	58k h	>72k h	>72k h	>72k h	>72k h
	70 °C	40k h	54k h	>72k h	>72k h	>72k h	>72k h
	75 °C	38k h	51k h	>72k h	>72k h	>72k h	>72k h
	80 °C	35k h	47k h	>72k h	>72k h	>72k h	>72k h
	370 mA / ft (280 mm module length)	40 °C	54k h	>72k h	>72k h	>72k h	>72k h
45 °C		51k h	69k h	>72k h	>72k h	>72k h	>72k h
50 °C		47k h	64k h	>72k h	>72k h	>72k h	>72k h
55 °C		44k h	60k h	>72k h	>72k h	>72k h	>72k h
60 °C		41k h	55k h	>72k h	>72k h	>72k h	>72k h
65 °C		39k h	52k h	>72k h	>72k h	>72k h	>72k h
70 °C		36k h	48k h	>72k h	>72k h	>72k h	>72k h
75 °C		34k h	45k h	69k h	>72k h	>72k h	>72k h
80 °C		31k h	42k h	64k h	>72k h	>72k h	>72k h

LOC10 >72k h. At tp rated, based on 10 switching cycles per day.

4.3 Switching capability

100,000 cycles

Tridonic test according to IEC 62717 Cl 10.3.3
30 s on / 30 s off at Imax

5. Electrical values

5.1 Declaration of electrical parameters

Irated ... Nominal operating current the module is designed for.

I_{max} ... Max. permissible continuous operating current incl. The tolerances of the LED driver.

Max. permissible LF current ripple ... Max. output current of the LED driver incl. Tolerances and LF current ripple must not exceed this value.

Max. permissible peak current ... The max. output peak current of the LED driver must not exceed this value.

5.2 Typ. forward voltage vs. forward current

LLE 24x140mm 550lm 827-865 LV PRE3

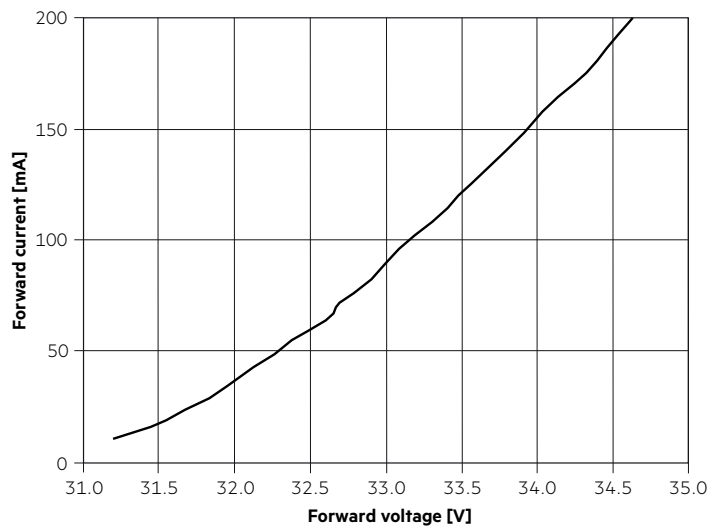

LLE 24x280mm 1100lm 827-865 LV PRE3

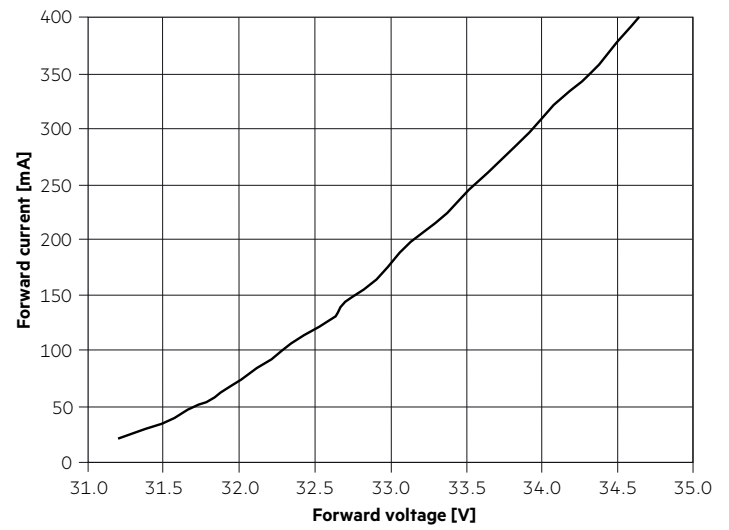

LLE 24x560mm 2200lm 827-865 LV PRE3

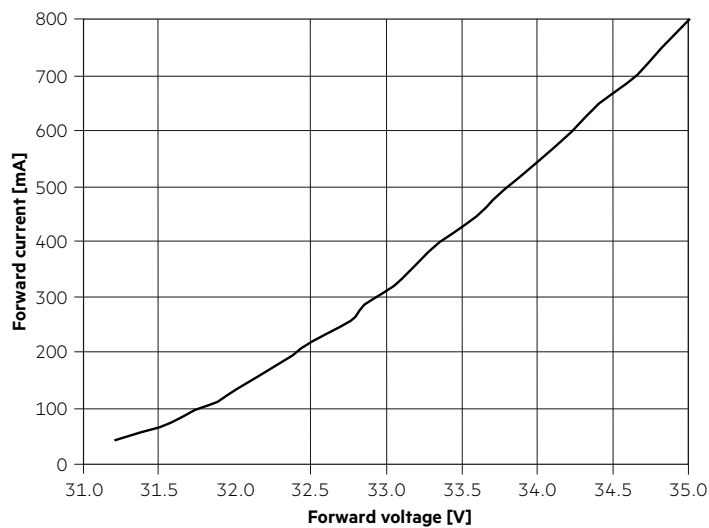

5.3 Forward voltage vs. tc temperature

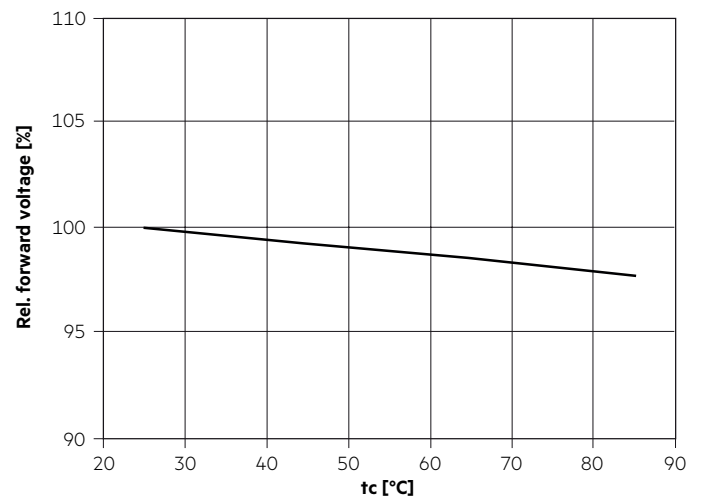

The diagrams are based on statistic values.
The real values can be different.

6. Photometric characteristics

6.1 Coordinates and tolerances according to CIE 1931

The specified colour coordinates are integral measured by a current impulse with typical values of module and a duration of 100 ms.
The ambient temperature of the measurement is $t_a = 25^\circ\text{C}$.
The measurement tolerance of the colour coordinates are ± 0.01 .

Module type	Current impulse
LLE 24x140mm 550lm 827-865 LV PRE3	65 mA
LLE 24x280mm 1100lm 827-865 LV PRE3	130 mA
LLE 24x560mm 2200lm 827-865 LV PRE3	260 mA

2,700 K

	x0	y0
Centre	0.4578	0.4101

MacAdam ellipse: 3SDCM

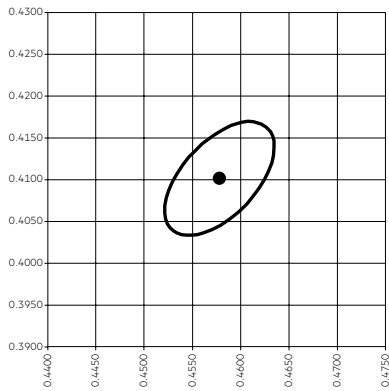

TM30		CRI	
Rf	Rg	Ra	R9
83	96	83	12

Colour vector graphic

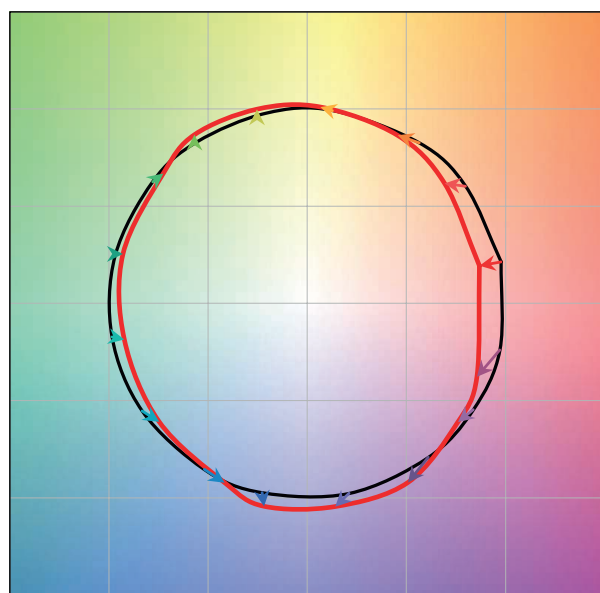

— Reference source
— Test source

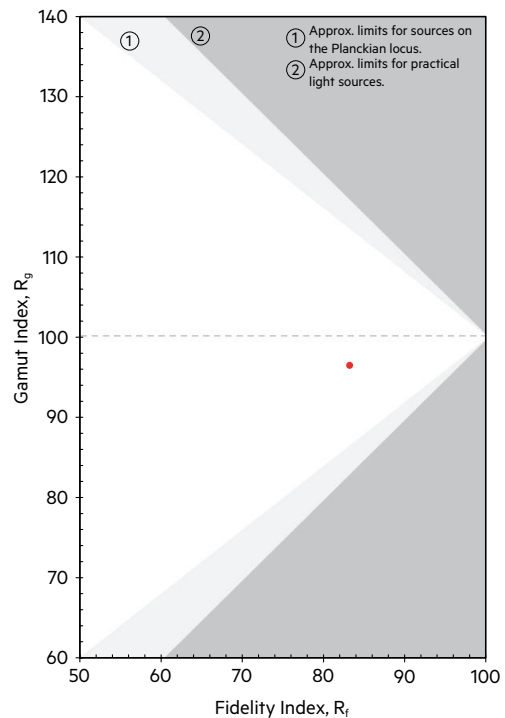

6,500 K

	x0	y0
Centre	0.3123	0.3282

MacAdam ellipse: 3SDCM

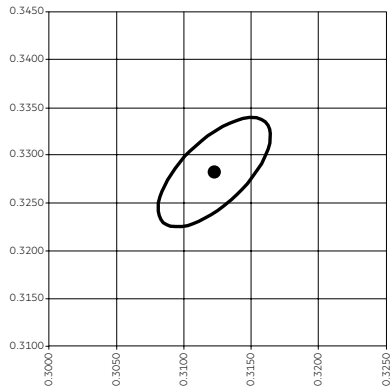

TM30		CRI	
Rf	Rg	Ra	R9
80	97	81	8

Colour vector graphic

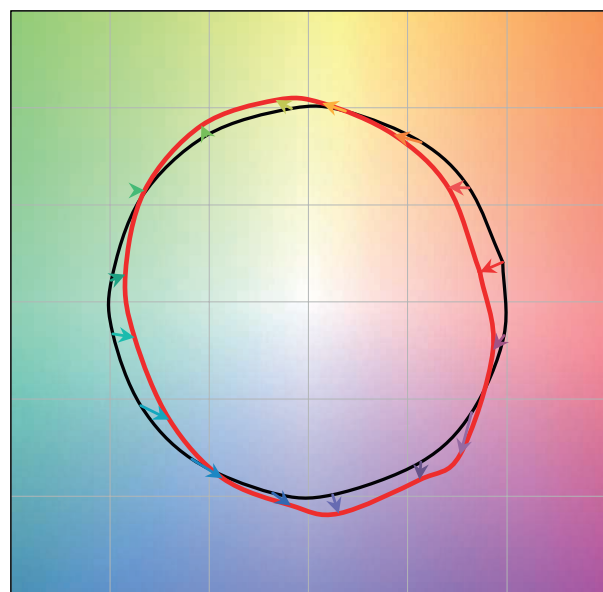

— Reference source
— Test source

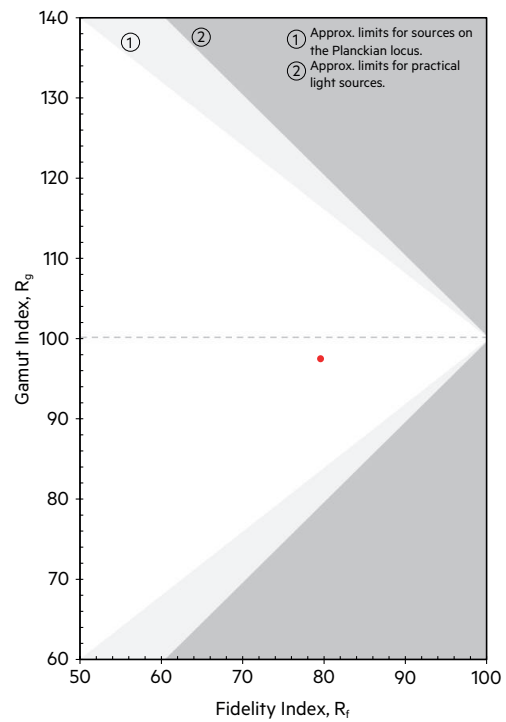

Colour spectrum at different colour temperatures

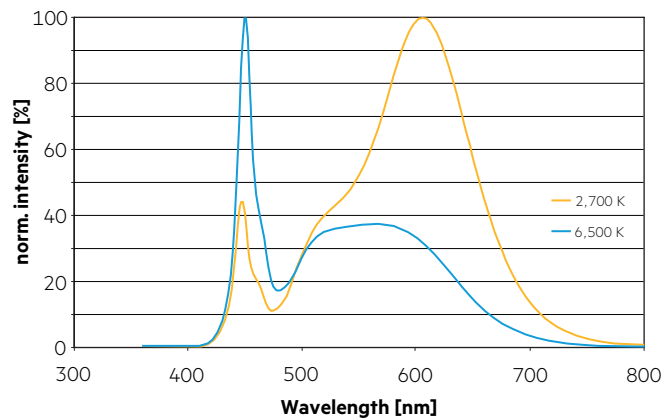

6.2 Light distribution

The optical design of the LLE product line ensures optimum homogeneity for the light distribution.



The colour temperature is measured integral over the complete module.
To ensure an ideal mixture of colours and a homogeneous light distribution a suitable optic (e. g. PMMA diffuser) and a sufficient spacing between module and optic (typ. 6 cm) should be used.

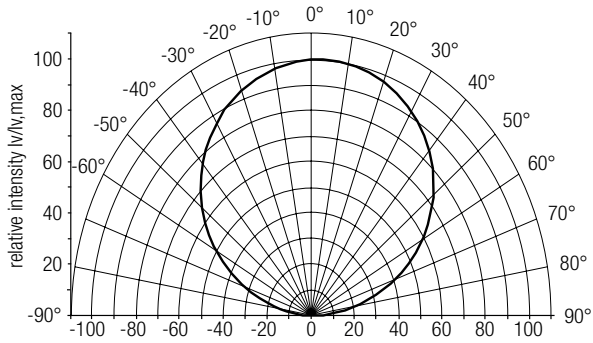

The diagrams are based on statistic values.

6.3 Relative luminous flux vs. operating temperature

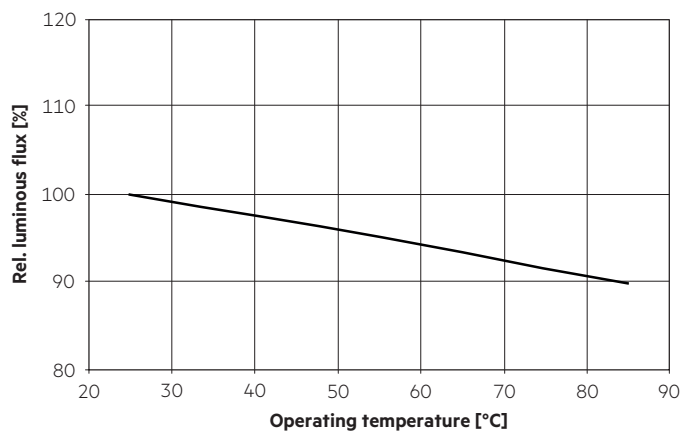

6.4 Relative luminous flux vs. operating current

LLE 24x140mm 550lm 827-865 LV PRE3

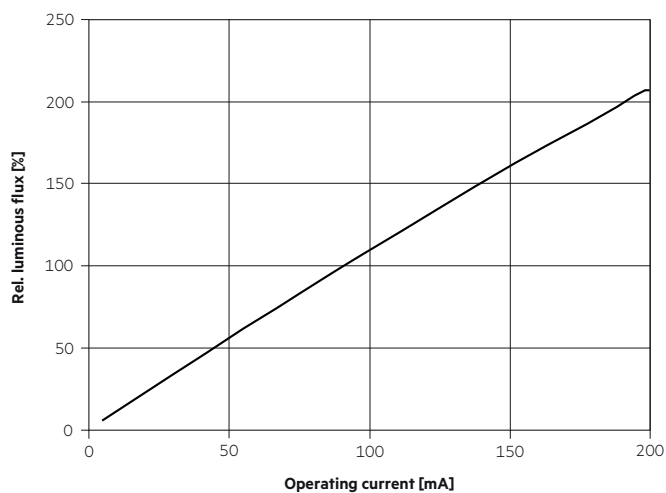

LLE 24x280mm 1100lm 827-865 LV PRE3

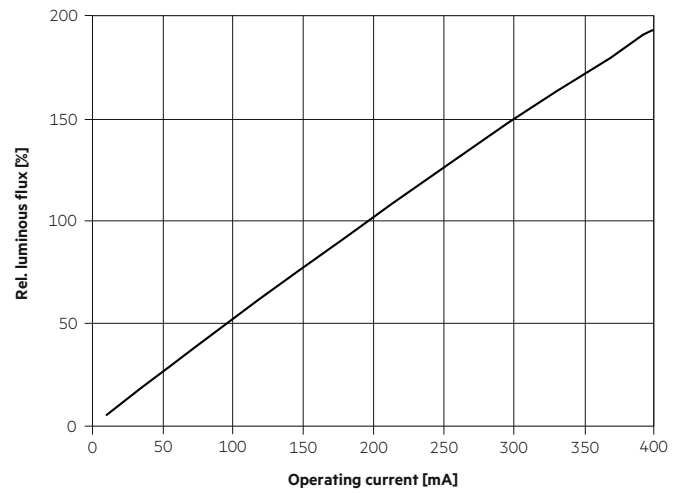

LLE 24x560mm 2200lm 827-865 LV PRE3

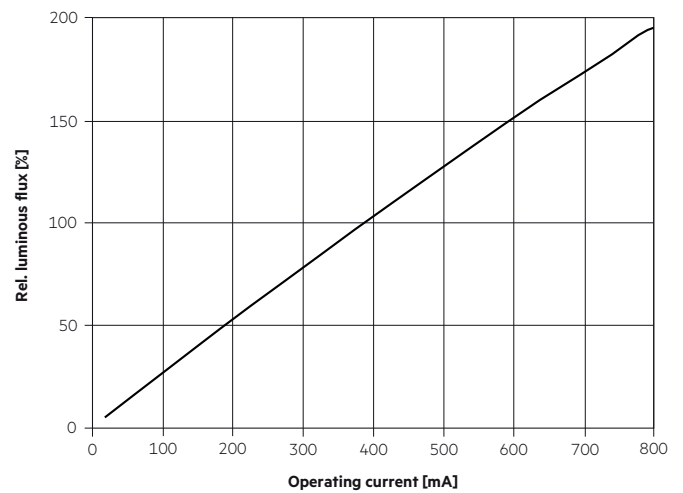

7. Miscellaneous

7.1 Additional information

Additional technical information Design-in Guide, 3D data, photometric data and Guarantee conditions at www.tridonic.com

Guarantee conditions at www.tridonic.com → Services

Lifetime declarations are informative and represent no warranty claim.