

Module LLE 16mm 650lm HV ADV6

Modules LLE advanced



LLE 16x140mm 325lm HV ADV6



LLE 16x280mm 650lm HV ADV6



LLE 16x560mm 1300lm HV ADV6

Product description

- _ Ideal for compact linear luminaire designs
- _ Homogenous illumination thanks to small package distance
- _ 2 terminals for serial wiring
- _ Perfectly uniform light, even if several LED modules are used together in a line
- _ Push terminals for quick and simple wiring of LED module to LED module
- _ HE ... High Efficiency, NM ... Nominal Mode, HO ... High Output
- _ Long lifetime up to 102,000 hours
- _ 5 years guarantee (Conditions at <https://www.tridonic.com/en/int/services/manufacturer-guarantee-conditions>)

Optical properties

- _ Colour temperatures 2,700, 3,000, 3,500, 4,000, 5,000 and 6,500 K
- _ Efficacy of the LED module 211 lm/W at Irated and tp = 25 °C
- _ High colour rendering index CRI > 80
- _ High colour consistency (MacAdam 3) ^①
- _ Small luminous flux tolerances

Mechanical properties

- _ Module dimension 16 x 140 mm, 16 x 280 mm and 16 x 560 mm
- _ Simple installation via clips or screws

System solution

- _ Integrate compatible partner products into your final system solution:
<https://www.tridonic.com/en/int/products/accessories#partner>
- _ Combine Tridonic's LED modules and dimmable drivers to achieve an outstanding system efficacy (configuration possible via <https://setbuilder.tridonic.com/>)

^① Integral measurement over the complete module.

Website

<http://www.tridonic.com/28004947>

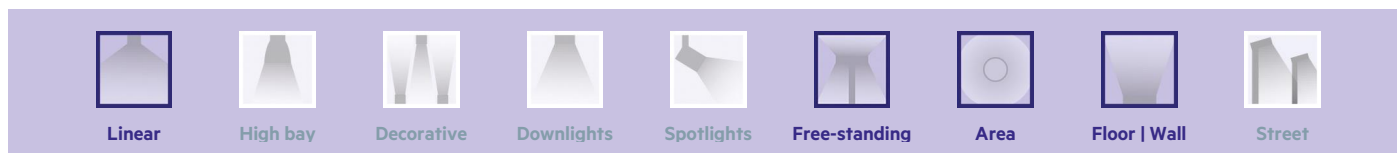
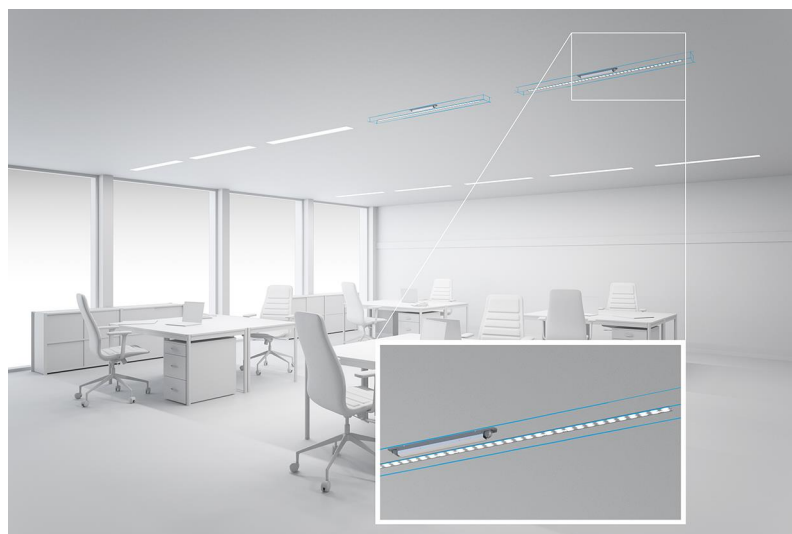

Module LLE 16mm 650lm HV ADV6

Modules LLE advanced

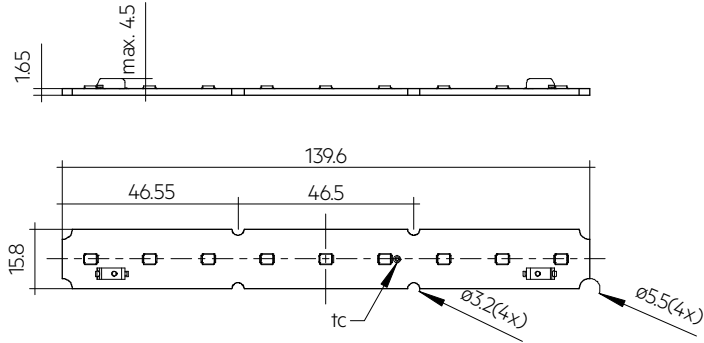

LLE 16x140mm 325lm HV ADV6

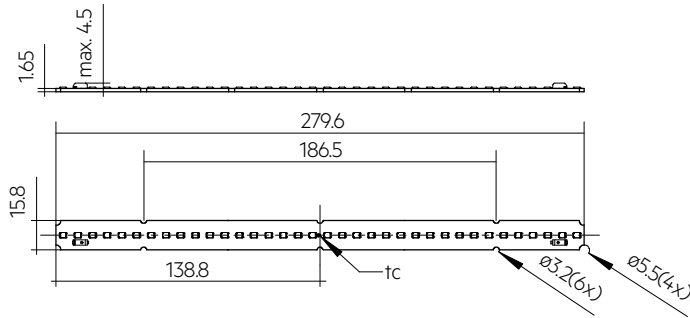

LLE 16x280mm 650lm HV ADV6

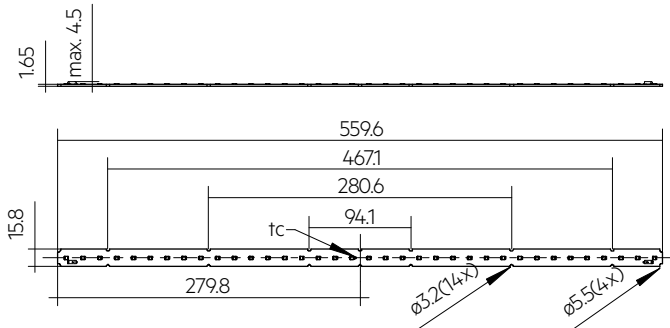

LLE 16x560mm 1300lm HV ADV6

Ordering data

Type	Article number	Colour temperature	Packaging, carton	Weight per pc.
LLE 16x140mm 325lm 827 HV ADV6	28004947	2,700 K	144 pc(s).	0.007 kg
LLE 16x140mm 325lm 830 HV ADV6	28004948	3,000 K	144 pc(s).	0.007 kg
LLE 16x140mm 325lm 835 HV ADV6	28004949	3,500 K	144 pc(s).	0.007 kg
LLE 16x140mm 325lm 840 HV ADV6	28004950	4,000 K	144 pc(s).	0.007 kg
LLE 16x140mm 325lm 850 HV ADV6	28004951	5,000 K	144 pc(s).	0.007 kg
LLE 16x140mm 325lm 865 HV ADV6	28004952	6,500 K	144 pc(s).	0.007 kg
LLE 16x280mm 650lm 827 HV ADV6	28004957	2,700 K	144 pc(s).	0.014 kg
LLE 16x280mm 650lm 830 HV ADV6	28004958	3,000 K	144 pc(s).	0.014 kg
LLE 16x280mm 650lm 835 HV ADV6	28004959	3,500 K	144 pc(s).	0.014 kg
LLE 16x280mm 650lm 840 HV ADV6	28004960	4,000 K	144 pc(s).	0.014 kg
LLE 16x280mm 650lm 850 HV ADV6	28004961	5,000 K	144 pc(s).	0.014 kg
LLE 16x280mm 650lm 865 HV ADV6	28004962	6,500 K	144 pc(s).	0.014 kg
LLE 16x560mm 1300lm 827 HV ADV6	28004970	2,700 K	144 pc(s).	0.028 kg
LLE 16x560mm 1300lm 830 HV ADV6	28004971	3,000 K	144 pc(s).	0.028 kg
LLE 16x560mm 1300lm 835 HV ADV6	28004972	3,500 K	144 pc(s).	0.028 kg
LLE 16x560mm 1300lm 840 HV ADV6	28004973	4,000 K	144 pc(s).	0.028 kg
LLE 16x560mm 1300lm 850 HV ADV6	28004974	5,000 K	144 pc(s).	0.028 kg
LLE 16x560mm 1300lm 865 HV ADV6	28004975	6,500 K	144 pc(s).	0.028 kg

Technical data

Beam characteristic	360°
Ambient temperature t_a	-40 ... +65 °C
t_p rated	50 °C
t_c	85 °C
I_{rated}	200 mA
I_{max}	700 mA
Max. permissible LF current ripple	800 mA
Max. permissible peak current	1,350 mA / max. 10 ms
Max. working voltage for insulation [®]	440 V
Insulation test voltage	1.88 kV
Colour tolerance	3 SDCM
ESD classification	Severity level 2
Risk group (IEC 62471)	RG1 (> 280 – 700 mA (I_{max})), RGO (\leq 280 mA)
Classification acc. to IEC 62031	Built-in
Type of protection	IP00
Lumen maintenance L70B50	102,000 h
Guarantee (conditions at www.tridonic.com)	5 Year(s)

Approval marks**Standards**

IEC 62031, IEC 62471, IEC 61000-4-2, IEC 62778, IEC 61547

Specific technical data

Type	Article number	Photometric code ^②	Useful luminous flux at tp = 25 °C ^③	Expected luminous flux at tp rated ^④	Typ. forward current	Min. forward voltage at tp rated	Max. forward voltage at tp = 25 °C	Power consumption Pon at tp = 25 °C ^⑤	Efficacy of the module at tp = 25 °C	Expected efficacy of the module at tp rated	Colour rendering index CRI
Operating mode HE											
LLE 16x140mm 325lm 827 HV ADV6	28004947	827/359	-	153 lm	100 mA	7.6 V	8.2 V	-	-	193 lm/W	>80
LLE 16x140mm 325lm 830 HV ADV6	28004948	830/359	-	156 lm	100 mA	7.6 V	8.2 V	-	-	197 lm/W	>80
LLE 16x140mm 325lm 835 HV ADV6	28004949	835/359	-	161 lm	100 mA	7.6 V	8.2 V	-	-	204 lm/W	>80
LLE 16x140mm 325lm 840 HV ADV6	28004950	840/359	-	166 lm	100 mA	7.6 V	8.2 V	-	-	209 lm/W	>80
LLE 16x140mm 325lm 850 HV ADV6	28004951	850/359	-	165 lm	100 mA	7.6 V	8.2 V	-	-	208 lm/W	>80
LLE 16x140mm 325lm 865 HV ADV6	28004952	865/359	-	162 lm	100 mA	7.6 V	8.2 V	-	-	205 lm/W	>80
LLE 16x280mm 650lm 827 HV ADV6	28004957	827/359	-	305 lm	100 mA	15.1 V	16.5 V	-	-	193 lm/W	>80
LLE 16x280mm 650lm 830 HV ADV6	28004958	830/359	-	312 lm	100 mA	15.1 V	16.5 V	-	-	197 lm/W	>80
LLE 16x280mm 650lm 835 HV ADV6	28004959	835/359	-	323 lm	100 mA	15.1 V	16.5 V	-	-	204 lm/W	>80
LLE 16x280mm 650lm 840 HV ADV6	28004960	840/359	-	331 lm	100 mA	15.1 V	16.5 V	-	-	209 lm/W	>80
LLE 16x280mm 650lm 850 HV ADV6	28004961	850/359	-	329 lm	100 mA	15.1 V	16.5 V	-	-	208 lm/W	>80
LLE 16x280mm 650lm 865 HV ADV6	28004962	865/359	-	325 lm	100 mA	15.1 V	16.5 V	-	-	205 lm/W	>80
LLE 16x560mm 1300lm 827 HV ADV6	28004970	827/359	-	610 lm	100 mA	30.2 V	32.9 V	-	-	193 lm/W	>80
LLE 16x560mm 1300lm 830 HV ADV6	28004971	830/359	-	624 lm	100 mA	30.2 V	32.9 V	-	-	197 lm/W	>80
LLE 16x560mm 1300lm 835 HV ADV6	28004972	835/359	-	646 lm	100 mA	30.2 V	32.9 V	-	-	204 lm/W	>80
LLE 16x560mm 1300lm 840 HV ADV6	28004973	840/359	-	662 lm	100 mA	30.2 V	32.9 V	-	-	208 lm/W	>80
LLE 16x560mm 1300lm 850 HV ADV6	28004974	850/359	-	658 lm	100 mA	30.2 V	32.9 V	-	-	208 lm/W	>80
LLE 16x560mm 1300lm 865 HV ADV6	28004975	865/359	-	649 lm	100 mA	30.2 V	32.9 V	-	-	205 lm/W	>80
Operating mode NM											
LLE 16x140mm 325lm 827 HV ADV6	28004947	827/359	318 lm	305 lm	200 mA	7.7 V	8.4 V	1.6 W	195 lm/W	189 lm/W	>80
LLE 16x140mm 325lm 830 HV ADV6	28004948	830/359	326 lm	313 lm	200 mA	7.7 V	8.4 V	1.6 W	199 lm/W	193 lm/W	>80
LLE 16x140mm 325lm 835 HV ADV6	28004949	835/359	337 lm	323 lm	200 mA	7.7 V	8.4 V	1.6 W	206 lm/W	200 lm/W	>80
LLE 16x140mm 325lm 840 HV ADV6	28004950	840/359	345 lm	331 lm	200 mA	7.7 V	8.4 V	1.6 W	211 lm/W	205 lm/W	>80
LLE 16x140mm 325lm 850 HV ADV6	28004951	850/359	343 lm	329 lm	200 mA	7.7 V	8.4 V	1.6 W	210 lm/W	204 lm/W	>80
LLE 16x140mm 325lm 865 HV ADV6	28004952	865/359	339 lm	325 lm	200 mA	7.7 V	8.4 V	1.6 W	207 lm/W	201 lm/W	>80
LLE 16x280mm 650lm 827 HV ADV6	28004957	827/359	636 lm	611 lm	200 mA	15.5 V	16.8 V	3.3 W	195 lm/W	189 lm/W	>80
LLE 16x280mm 650lm 830 HV ADV6	28004958	830/359	651 lm	625 lm	200 mA	15.5 V	16.8 V	3.3 W	199 lm/W	193 lm/W	>80
LLE 16x280mm 650lm 835 HV ADV6	28004959	835/359	673 lm	646 lm	200 mA	15.5 V	16.8 V	3.3 W	206 lm/W	200 lm/W	>80
LLE 16x280mm 650lm 840 HV ADV6	28004960	840/359	691 lm	663 lm	200 mA	15.5 V	16.8 V	3.3 W	211 lm/W	205 lm/W	>80
LLE 16x280mm 650lm 850 HV ADV6	28004961	850/359	686 lm	659 lm	200 mA	15.5 V	16.8 V	3.3 W	210 lm/W	203 lm/W	>80
LLE 16x280mm 650lm 865 HV ADV6	28004962	865/359	677 lm	650 lm	200 mA	15.5 V	16.8 V	3.3 W	207 lm/W	201 lm/W	>80
LLE 16x560mm 1300lm 827 HV ADV6	28004970	827/359	1,273 lm	1,222 lm	200 mA	30.9 V	33.6 V	6.5 W	195 lm/W	189 lm/W	>80
LLE 16x560mm 1300lm 830 HV ADV6	28004971	830/359	1,302 lm	1,250 lm	200 mA	30.9 V	33.6 V	6.5 W	199 lm/W	193 lm/W	>80
LLE 16x560mm 1300lm 835 HV ADV6	28004972	835/359	1,346 lm	1,292 lm	200 mA	30.9 V	33.6 V	6.5 W	206 lm/W	200 lm/W	>80
LLE 16x560mm 1300lm 840 HV ADV6	28004973	840/359	1,381 lm	1,326 lm	200 mA	30.9 V	33.6 V	6.5 W	210 lm/W	203 lm/W	>80
LLE 16x560mm 1300lm 850 HV ADV6	28004974	850/359	1,372 lm	1,317 lm	200 mA	30.9 V	33.6 V	6.5 W	210 lm/W	203 lm/W	>80
LLE 16x560mm 1300lm 865 HV ADV6	28004975	865/359	1,354 lm	1,299 lm	200 mA	30.9 V	33.6 V	6.5 W	207 lm/W	201 lm/W	>80
Operating mode HO											
LLE 16x140mm 325lm 827 HV ADV6	28004947	827/359	-	855 lm	600 mA	8.2 V	8.9 V	-	-	166 lm/W	>80
LLE 16x140mm 325lm 830 HV ADV6	28004948	830/359	-	875 lm	600 mA	8.2 V	8.9 V	-	-	170 lm/W	>80
LLE 16x140mm 325lm 835 HV ADV6	28004949	835/359	-	905 lm	600 mA	8.2 V	8.9 V	-	-	175 lm/W	>80
LLE 16x140mm 325lm 840 HV ADV6	28004950	840/359	-	928 lm	600 mA	8.2 V	8.9 V	-	-	180 lm/W	>80
LLE 16x140mm 325lm 850 HV ADV6	28004951	850/359	-	922 lm	600 mA	8.2 V	8.9 V	-	-	179 lm/W	>80
LLE 16x140mm 325lm 865 HV ADV6	28004952	865/359	-	910 lm	600 mA	8.2 V	8.9 V	-	-	176 lm/W	>80
LLE 16x280mm 650lm 827 HV ADV6	28004957	827/359	-	1,710 lm	600 mA	16.5 V	17.8 V	-	-	166 lm/W	>80
LLE 16x280mm 650lm 830 HV ADV6	28004958	830/359	-	1,750 lm	600 mA	16.5 V	17.8 V	-	-	170 lm/W	>80
LLE 16x280mm 650lm 835 HV ADV6	28004959	835/359	-	1,809 lm	600 mA	16.5 V	17.8 V	-	-	176 lm/W	>80
LLE 16x280mm 650lm 840 HV ADV6	28004960	840/359	-	1,856 lm	600 mA	16.5 V	17.8 V	-	-	180 lm/W	>80
LLE 16x280mm 650lm 850 HV ADV6	28004961	850/359	-	1,844 lm	600 mA	16.5 V	17.8 V	-	-	179 lm/W	>80
LLE 16x280mm 650lm 865 HV ADV6	28004962	865/359	-	1,819 lm	600 mA	16.5 V	17.8 V	-	-	177 lm/W	>80
LLE 16x560mm 1300lm 827 HV ADV6	28004970	827/359	-	3,420 lm	600 mA	32.9 V	35.6 V	-	-	166 lm/W	>80
LLE 16x560mm 1300lm 830 HV ADV6	28004971	830/359	-	3,499 lm	600 mA	32.9 V	35.6 V	-	-	170 lm/W	>80
LLE 16x560mm 1300lm 835 HV ADV6	28004972	835/359	-	3,618 lm	600 mA	32.9 V	35.6 V	-	-	176 lm/W	>80
LLE 16x560mm 1300lm 840 HV ADV6	28004973	840/359	-	3,711 lm	600 mA	32.9 V	35.6 V	-	-	179 lm/W	>80
LLE 16x560mm 1300lm 850 HV ADV6	28004974	850/359	-	3,687 lm	600 mA	32.9 V	35.6 V	-	-	179 lm/W	>80
LLE 16x560mm 1300lm 865 HV ADV6	28004975	865/359	-	3,638 lm	600 mA	32.9 V	35.6 V	-	-	177 lm/W	>80

② If mounted with M3 screws with 6 mm head diameter and plastic washer.

③ The detailed explanation, see data sheet section 1.1.

④ Tolerance of useful light flux - 0 % / + 15 %. Measurement uncertainty ± 10 %.

⑤ Measurement uncertainty ± 10 %. Based on calculation.

⑥ Tolerance of power consumption Pon ± 10 %. Measurement uncertainty ± 5 %.

ACL BRIDGE LLE16

Accessory

**Product description**

- _ Clip for fixation for LLE16
- _ Fast snap on mounting (for sheet thickness 0.5 – 1.0 mm)
- _ For drilling hole 3 mm
- _ Clip made of polycarbonate
- _ Minimum sales quantity 200 pcs.

Website

<http://www.tridonic.com/28001035>

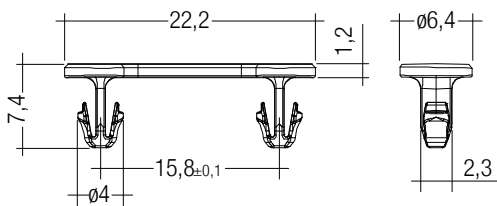
**Ordering data**

Type	Article number	Colour	Packaging, bag	Weight per pc.
ACL BRIDGE LLE16 PUSH-FIX	28001035	White	200 pc(s).	0.001 kg

ACL LINEAR COVER 16mm

Accessory

**Product description**

- _ LINEAR COVER for LLE 16
- _ Protection against direct touch for non-SELV applications (recommendation: use all fixing points) ^①
- _ Fast snap on mounting on to LLE 16 with clips or plastic washers
- _ High transmission: transparent, semi-transparent and diffuse
- _ Linear lense made of PMMA
- _ Tolerances LINEAR COVER: + 10 mm for 1,600 / 1,200 mm length (ends raw)

① Ends must be covered by the luminaire construction.

Website

<http://www.tridonic.com/28000950>

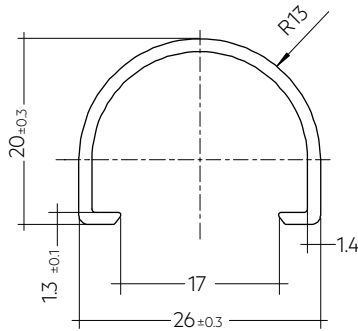
**Ordering data**

Type	Article number	Colour	Length L	Packaging, carton	Weight per pc.
ACL LINEAR COVER 16x1600mm FROSTED	28000950	Semi-transparent	1,600 mm	24 pc(s).	0.147 kg
ACL LINEAR COVER 16x1200mm FROSTED	28002827	Semi-transparent	1,200 mm	24 pc(s).	0.100 kg
ACL LINEAR COVER 16x1600mm DIFFUSE	28000951	Diffuse	1,600 mm	24 pc(s).	0.147 kg
ACL LINEAR COVER 16x1200mm DIFFUSE	28002828	Diffuse	1,200 mm	24 pc(s).	0.100 kg

1. Standards

IEC 62031
IEC 62471
IEC 61000-4-2
IEC 62778
IEC 61547

1.1 Photometric code

Key for photometric code, e. g. 830 / 349

1 st digit	2 nd + 3 rd digit	4 th digit	5 th digit	6 th digit		
Code	Colour temperature in Kelvin x 100	MacAdam initial	MacAdam after 25% of the lifetime (max.6000h)	Luminous flux after 25% of the lifetime (max.6000h)		
CRI				Code	Luminous flux	
7				70 – 79	7	≥ 70 %
8				80 – 89	8	≥ 80 %
9	≥90	9	≥ 90 %			

1.2 Risk group

Forward current	Risk group (IEC 62471)
≤ 280 mA	RG0
> 280 – 700 mA (Imax)	RG1

1.3 Energy classification

Type	Colour temperature	Forward current	Energy classification	Energy consumption
LLE 16x140mm 325lm 827 HV ADV6	2,700 K	200 mA	C	2 kWh / 1,000 h
LLE 16x140mm 325lm 830 HV ADV6	3,000 K	200 mA	B	2 kWh / 1,000 h
LLE 16x140mm 325lm 835 HV ADV6	3,500 K	200 mA	B	2 kWh / 1,000 h
LLE 16x140mm 325lm 840 HV ADV6	4,000 K	200 mA	B	2 kWh / 1,000 h
LLE 16x140mm 325lm 850 HV ADV6	5,000 K	200 mA	B	2 kWh / 1,000 h
LLE 16x140mm 325lm 865 HV ADV6	6,500 K	200 mA	B	2 kWh / 1,000 h
LLE 16x280mm 650lm 827 HV ADV6	2,700 K	200 mA	C	4 kWh / 1,000 h
LLE 16x280mm 650lm 830 HV ADV6	3,000 K	200 mA	C	4 kWh / 1,000 h
LLE 16x280mm 650lm 835 HV ADV6	3,500 K	200 mA	B	4 kWh / 1,000 h
LLE 16x280mm 650lm 840 HV ADV6	4,000 K	200 mA	B	4 kWh / 1,000 h
LLE 16x280mm 650lm 850 HV ADV6	5,000 K	200 mA	B	4 kWh / 1,000 h
LLE 16x280mm 650lm 865 HV ADV6	6,500 K	200 mA	B	4 kWh / 1,000 h
LLE 16x560mm 1300lm 827 HV ADV6	2,700 K	200 mA	C	7 kWh / 1,000 h
LLE 16x560mm 1300lm 830 HV ADV6	3,000 K	200 mA	B	7 kWh / 1,000 h
LLE 16x560mm 1300lm 835 HV ADV6	3,500 K	200 mA	B	7 kWh / 1,000 h
LLE 16x560mm 1300lm 840 HV ADV6	4,000 K	200 mA	B	7 kWh / 1,000 h
LLE 16x560mm 1300lm 850 HV ADV6	5,000 K	200 mA	B	7 kWh / 1,000 h
LLE 16x560mm 1300lm 865 HV ADV6	6,500 K	200 mA	B	7 kWh / 1,000 h

Energy label and further information at www.tridonic.com in the certificates tab of the corresponding product page and at the EPREL data base <https://eprel.ec.europa.eu/>

2. Thermal details

2.1 tc point, ambient temperature and lifetime

The temperature at tp reference point is crucial for the light output and lifetime of a LED product.

For LLE a tp temperature of 50 °C has to be complied in order to achieve an optimum between heat sink requirements, light output and lifetime.

Compliance with the maximum permissible reference temperature at the tc point must be checked under operating conditions in a thermally stable state. The maximum value must be determined under worst-case conditions for the relevant application.

The tc and tp temperature of LED modules from Tridonic are measured at the same reference point.

2.2 Storage and humidity

Storage temperature	-40...+85 °C
---------------------	--------------

Operation only in non condensing environment.

Humidity during processing of the module should be between 30 to 70 %.

2.3 Heat sink values

LLE 16x140mm 325lm ADV6

ta	tp	Forward current	R _{th, hs-a}	Cooling area
25 °C	50 °C	200 mA		self cooling
25 °C	50 °C	600 mA	8.10 K/W	82 cm ²
35 °C	50 °C	200 mA	22.40 K/W	30 cm ²
35 °C	50 °C	600 mA	4.00 K/W	167 cm ²
40 °C	50 °C	200 mA	14.22 K/W	47 cm ²
40 °C	50 °C	600 mA	1.95 K/W	341 cm ²
45 °C	50 °C	200 mA	6.04 K/W	110 cm ²

LLE 16x280mm 650lm ADV6

ta	tp	Forward current	R _{th, hs-a}	Cooling area
25 °C	50 °C	200 mA		self cooling
25 °C	50 °C	600 mA	4.05 K/W	165 cm ²
35 °C	50 °C	200 mA	11.20 K/W	60 cm ²
35 °C	50 °C	600 mA	2.00 K/W	333 cm ²
40 °C	50 °C	200 mA	7.11 K/W	94 cm ²
40 °C	50 °C	600 mA	0.98 K/W	683 cm ²
45 °C	50 °C	200 mA	3.02 K/W	221 cm ²

LLE 16x560mm 1300lm ADV6

ta	tp	Forward current	R _{th, hs-a}	Cooling area
25 °C	50 °C	225 mA		self cooling
25 °C	50 °C	600 mA	2.02 K/W	329 cm ²
35 °C	50 °C	200 mA	5.60 K/W	119 cm ²
35 °C	50 °C	600 mA	1.00 K/W	666 cm ²
40 °C	50 °C	200 mA	3.56 K/W	188 cm ²
40 °C	50 °C	600 mA	0.49 K/W	1365 cm ²
45 °C	50 °C	200 mA	1.51 K/W	442 cm ²

Notes

The actual cooling surface can differ because of the material, the structural shape, outside influences and the installation situation. Depending on the heat sink a heat conducting paste or heat conducting film might be necessary to keep the specified tp temperature.

For applications with a small distance between LED module and lens or operating currents higher than 500 mA, screw mounting is recommended to ensure a reliable thermal connection between LED module and cooling surface.

3. Installation / wiring

3.1 Electrical supply/choice of LED driver

LLE modules from Tridonic are not protected against overvoltages, overcurrents, overloads or short-circuit currents. Safe and reliable operation can only be guaranteed in conjunction with a LED driver which complies with the relevant standards. The use of LED driver from Tridonic in combination with LLE modules guarantees the necessary protection for safe and reliable operation.

If a LED driver other than Tridonic is used, it must provide the following protection:

- Short-circuit protection
- Overload protection
- Overtemperature protection



LLE modules must be supplied by a constant current LED driver. Operation with a constant voltage LED driver will lead to an irreversible damage of the module.

Wrong polarity can damage the LLE.

The LLE module is designed for serial wiring.

LLE can be operated either from SELV LED drivers or from LED drivers with LV output voltage.



LLE are basic insulated up to 440 V (if mounted with M3 screws with head diameter 6 mm in combination with plastic washers) against ground and can be mounted directly on earthed metal parts of the luminaire. If the max. output voltage of the LED driver (also against earth) is above 440 V, an additional insulation between LED module and heat sink is required (for example by insulated thermal pads) or by a suitable luminaire construction.

At voltages > 60 V an additional protection against direct touch (test finger) to the light emitting side of the module has to be guaranteed. This is typically achieved by means of a non removable light distributor over the module.

3.2 Wiring

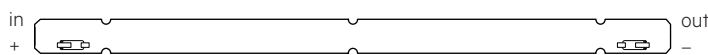

Wiring examples for serial wiring

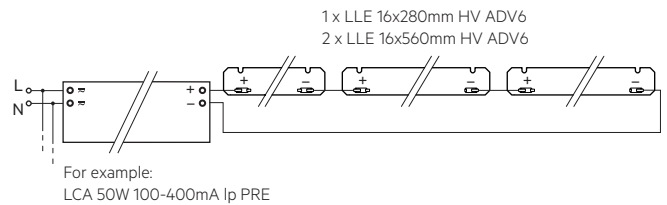
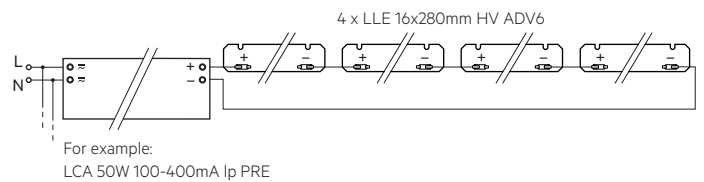

3.3 Wiring type and cross section

For wiring use solid wire from 0.14 to 0.5 mm².

No reconnection with smaller diameters possible if used with >0.34 mm².

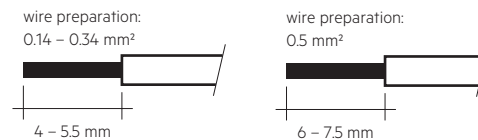

To remove the wires use a suitabel tool (Wago 206-859) or through twist and pull.

3.4 Mounting instruction



None of the components of the LLE (substrate, LED, electronic components etc.) may be exposed to tensile or compressive stresses.

Max. torque for fixing: 0.5 Nm.

The LED modules are mounted onto a heat sink with M3 screws with plastic washers or ACL BRIDGE LLE16 PUSH-FIX.

All fastening point must be used for mounting.

The cut-outs on the end faces must not be used for fastening.

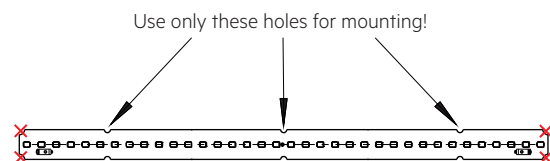

Chemical substance may harm the LED module. Chemical reactions could lead to colour shift, reduced luminous flux or a total failure of the module caused by corrosion of electrical connections.

Materials which are used in LED applications (e.g. sealings, adhesives) must not produce dissolver gas. They must not be condensation curing based, acetate curing based or contain sulfur, chlorine or phthalate.

Avoid corrosive atmosphere during usage and storage.

3.5 EOS/ESD safety guidelines



The device / module contains components that are sensitive to electrostatic discharge and may only be installed in the factory and on site if appropriate EOS/ESD protection measures have been taken. No special measures need be taken for devices/modules with enclosed casings (contact with the pc board not possible), just normal installation practice. Please note the requirements set out in the document EOS / ESD guidelines (Guideline_EOS_ESD.pdf) at: <http://www.tridonic.com/esd-protection>

4. Lifetime

4.1 Lifetime, lumen maintenance and failure rate

The light output of an LED module decreases over the lifetime, this is characterized with the L value.

L70 means that the LED module will give 70 % of its initial luminous flux.

This value is always related to the number of operation hours and therefore defines the lifetime of an LED module.

As the L value is a statistical value and the lumen maintenance may vary over the delivered LED modules.

The B value defines the amount of modules which are below the specific L value, e.g. L70B10 means 10 % of the LED modules are below 70 % of the initial luminous flux, respectively 90 % will be above 70 % of the initial value.

In addition the percentage of failed modules (fatal failure) is characterized by the C value.

4.2 Lumen maintenance for LLE 16mm HV ADV6

Forward current	tp						
	tempera- ture	L90 / B10	L90 / B50	L80 / B10	L80 / B50	L70 / B10	L70 / B50
700 mA	55 °C	52k h	52k h	> 102k h	> 102k h	> 102k h	> 102k h
	85 °C	52k h	52k h	> 102k h	> 102k h	> 102k h	> 102k h

L00C03 > 102k h. At tp rated and I rated, based on 10 swichting cycles per day.

4.3 Switching capability

100,000 cycles

Tridonic test according to IEC 62717 Cl 10.3.3

30 s on / 30 s off at I_{max}

5. Electrical values

5.1 Declaration of electrical parameters

I_{rated} ... Nominal operating current the module is designed for.

I_{max} ... Max. permissible continuous operating current incl. The tolerances of the LED driver.

Max. permissible LF current ripple ... Max. output current of the LED driver incl. Tolerances and LF current ripple must not exceed this value.

Max. permissible peak current ... The max. output peak current of the LED driver must not exceed this value.

5.2 Typ. forward voltage vs. forward current

LLE 16x140mm 325lm 8xx HV ADV6

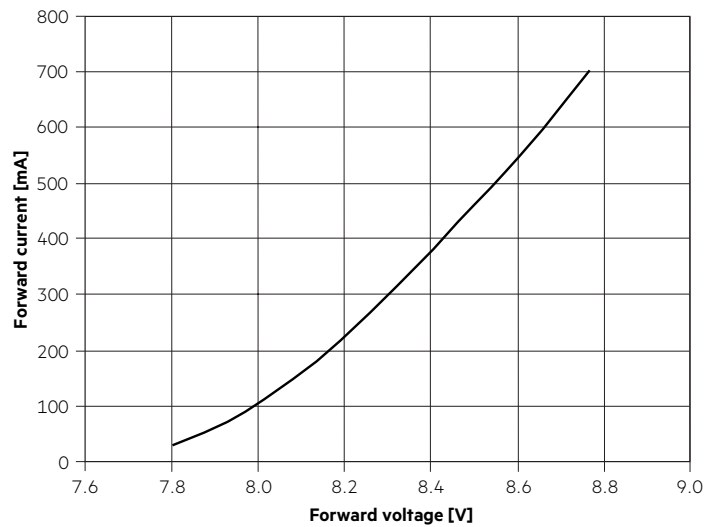

LLE 16x280mm 650lm 8xx HV ADV6

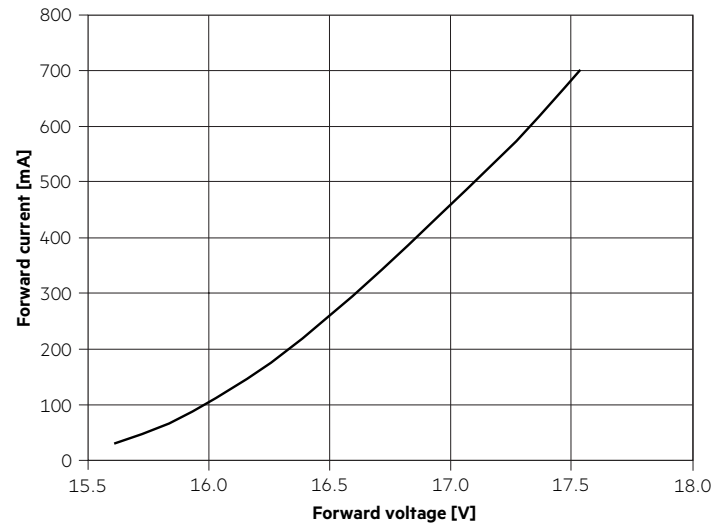

LLE 16x560mm 1300lm 8xx HV ADV6

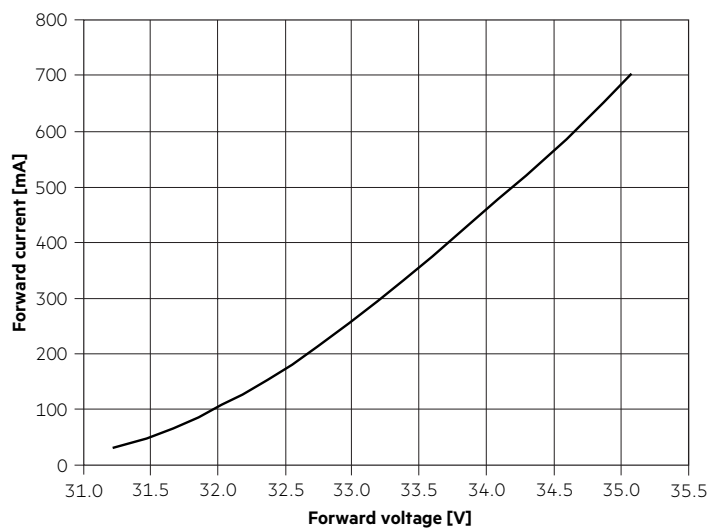

5.3 Forward voltage vs. tc temperature

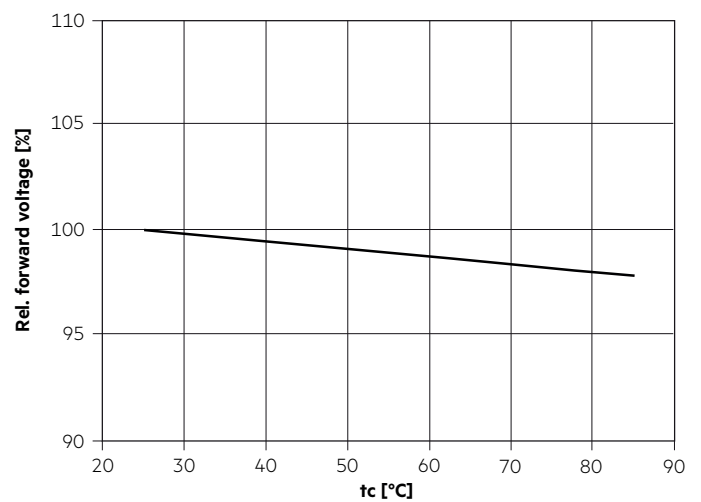

The diagrams are based on statistic values.
The real values can be different.

6. Photometric characteristics

6.1 Coordinates and tolerances according to CIE 1931

The specified colour coordinates are integral measured by current impulse of 195 mA and a duration of 100 ms.

The ambient temperature of the measurement is $t_a = 25^\circ\text{C}$.

The measurement tolerance of the colour coordinates are ± 0.01 .

2,700 K

	x0	y0
Centre	0.4578	0.4101

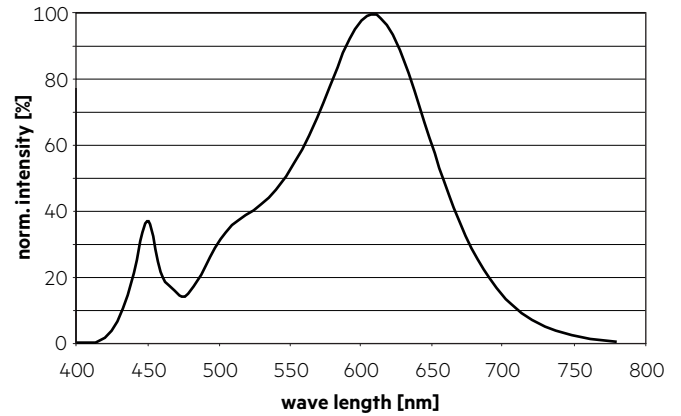
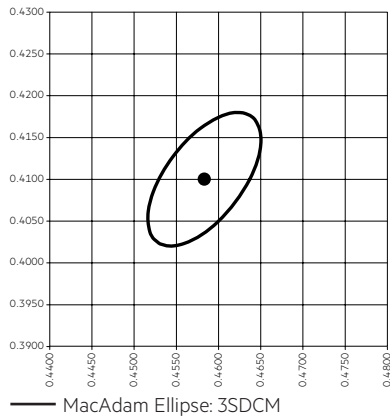

3,000 K

	x0	y0
Centre	0.4338	0.4030

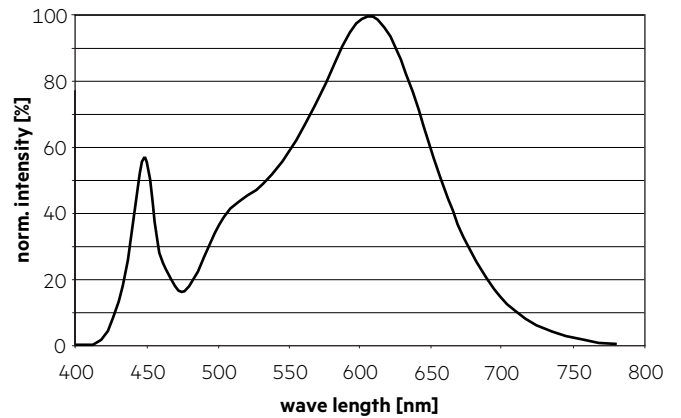
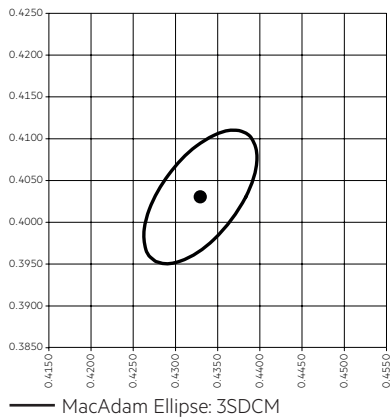

3,500 K

	x0	y0
Centre	0.4073	0.3917

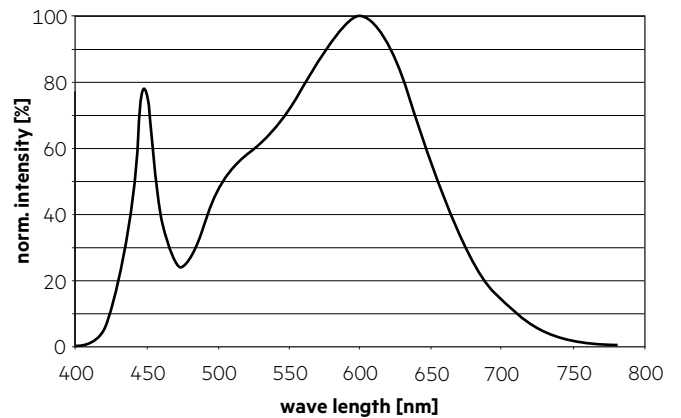
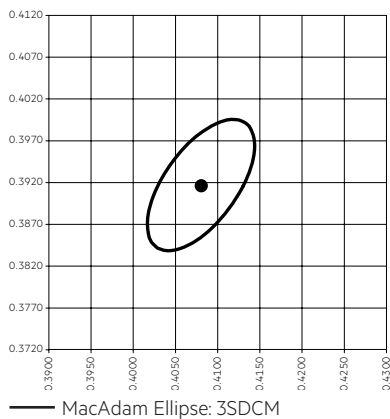

4,000 K

	x0	y0
Center	0.3818	0.3797

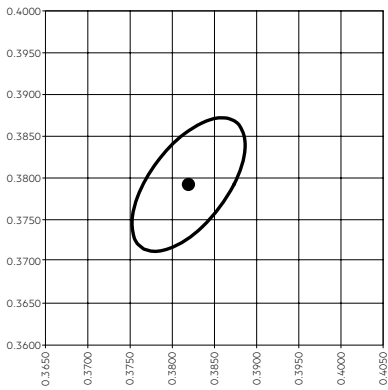

— MacAdam Ellipse: 3SDCM

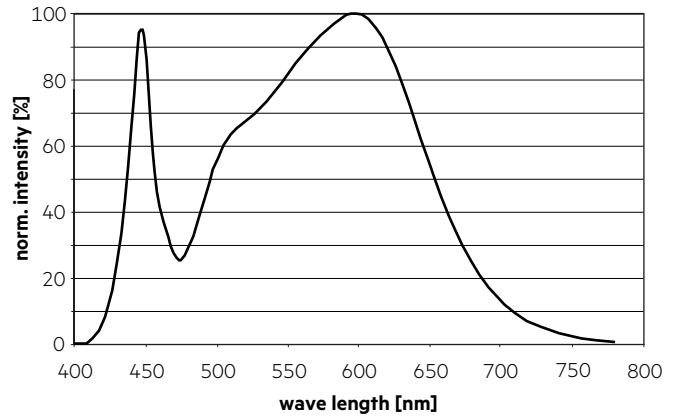

5,000 K

	x0	y0
Center	0.3447	0.3553

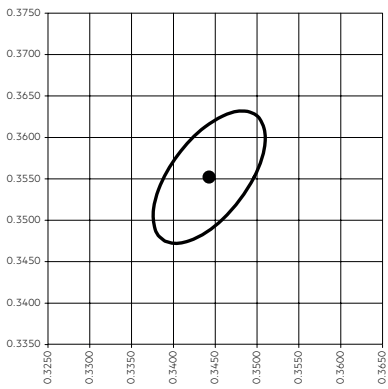

— MacAdam Ellipse: 3SDCM

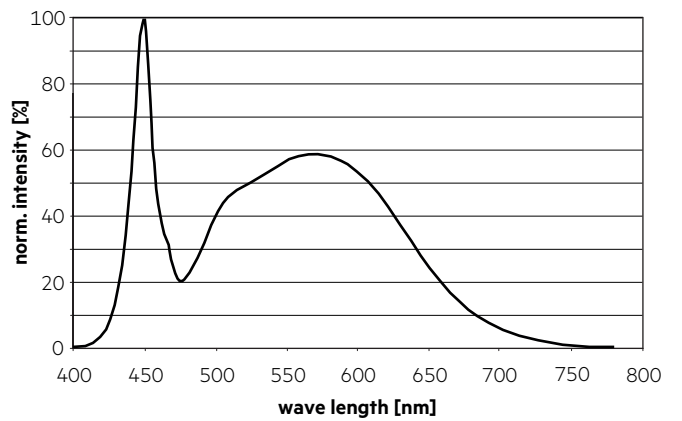

6,500 K

	x0	y0
Center	0.3123	0.3282

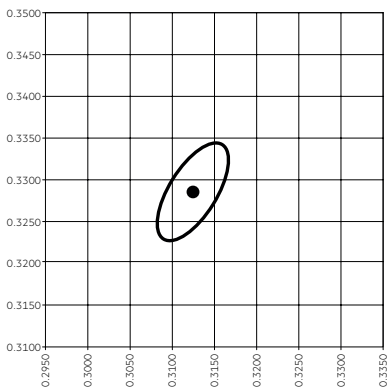

— MacAdam Ellipse: 3SDCM

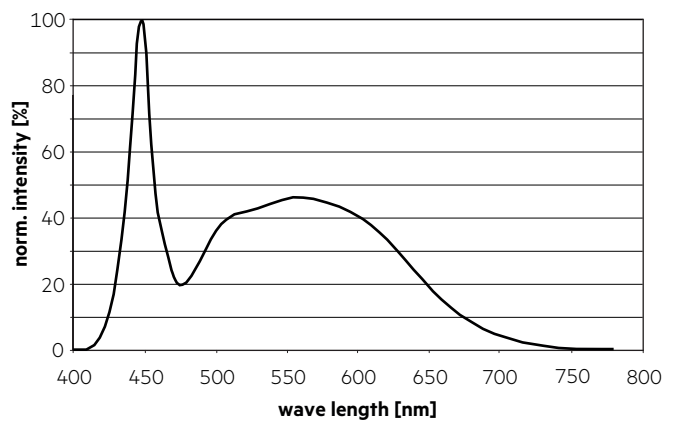

6.2 Light distribution

The optical design of the LLE product line ensures optimum homogeneity for the light distribution.

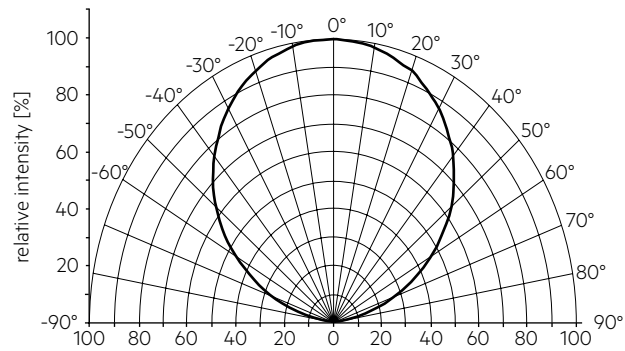

The colour temperature is measured integral over the complete module. The single LED light points can have deviations in the colour coordinates within MacAdam 5.

To ensure an ideal mixture of colours and a homogeneous light distribution a suitable optic (e. g. PMMA diffuser) and a sufficient spacing between module and optic (typ. 4 cm) should be used.

6.3 Relative luminous flux vs. tc temperature

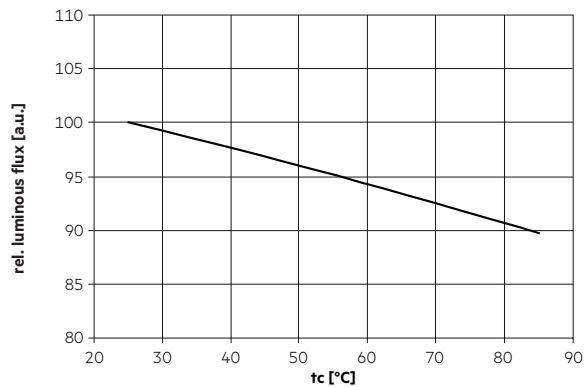

6.4 Relative luminous flux vs. operating current

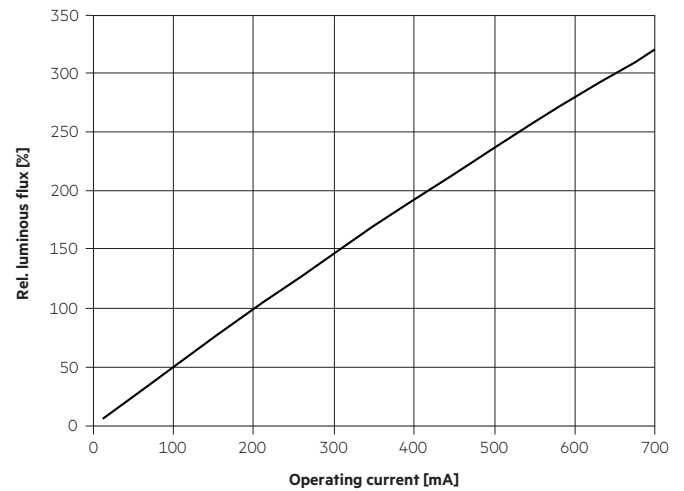

The diagrams are based on statistic values.
The real values can be different.

7. Miscellaneous

7.1 Additional information

Additional technical information at www.tridonic.com → Technical Data

Lifetime declarations are informative and represent no warranty claim.