

**Module LLE 16mm 650lm CRI90 HV ADV5**

Modules LLE advanced



LLE 16x140mm 325lm HV ADV5



LLE 16x280mm 650lm HV ADV5



LLE 16x560mm 1300lm HV ADV5

**Product description**

- \_ Ideal for compact linear luminaire designs
- \_ Homogenous illumination thanks to small package distance
- \_ 2 terminals for serial wiring
- \_ Perfectly uniform light, even if several LED modules are used together in a line
- \_ Push terminals for quick and simple wiring of LED module to LED module
- \_ HE ... High Efficiency, NM ... Nominal Mode, HO ... High Output
- \_ Long lifetime up to 72,000 hours
- \_ 5 years guarantee (Conditions at <https://www.tridonic.com/en/int/services/manufacturer-guarantee-conditions>)

**Optical properties**

- \_ Colour temperatures 2,700, 3,000, 3,500 and 4,000 K
- \_ Useful luminous flux 1,221 lm at Irated and tp = 25 °C
- \_ Efficacy of the LED module 166 lm/W at Irated and tp = 25 °C
- \_ High colour rendering index CRI > 90
- \_ High colour consistency (MacAdam 3) ①
- \_ Small luminous flux tolerances

**Mechanical properties**

- \_ Module dimension 16 x 140 mm, 16 x 280 mm and 16 x 560 mm
- \_ Simple installation via clips or screws

**System solution**

- \_ Combine Tridonic's LED modules and dimmable drivers to achieve an outstanding system efficacy (configuration possible via <https://setbuilder.tridonic.com/>)

① Integral measurement over the complete module.

**Website**

<http://www.tridonic.com/28003309>

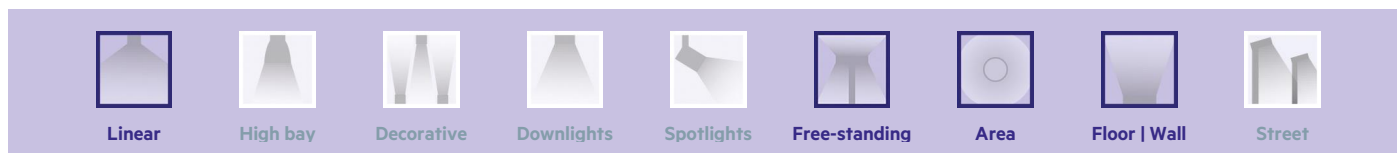
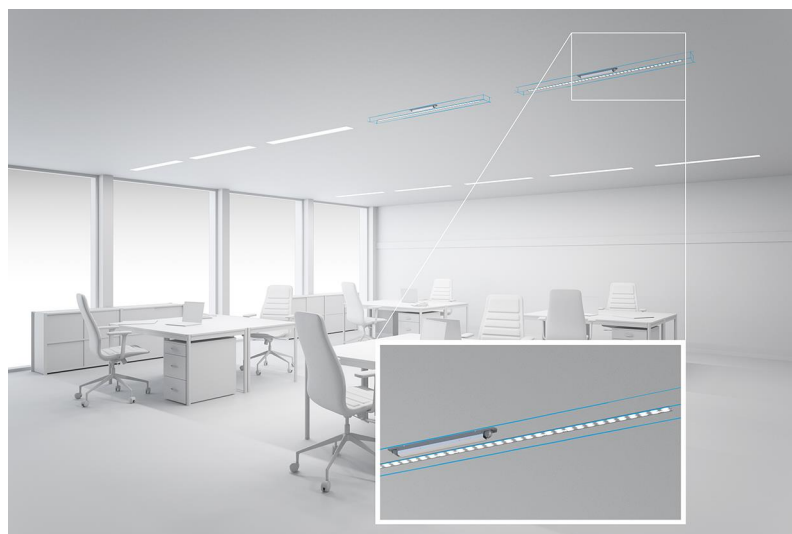

**Module LLE 16mm 650lm CRI90 HV ADV5**

Modules LLE advanced

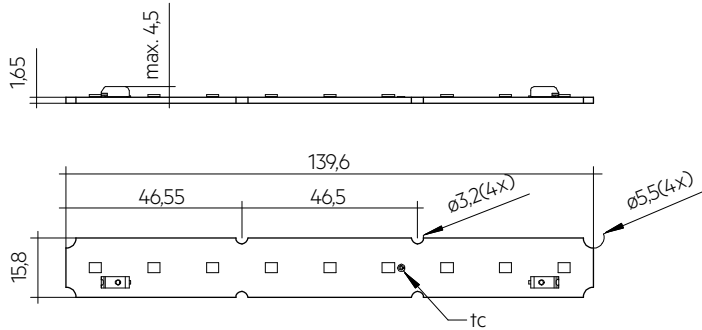

**LLE 16x140mm 325lm HV ADV5**

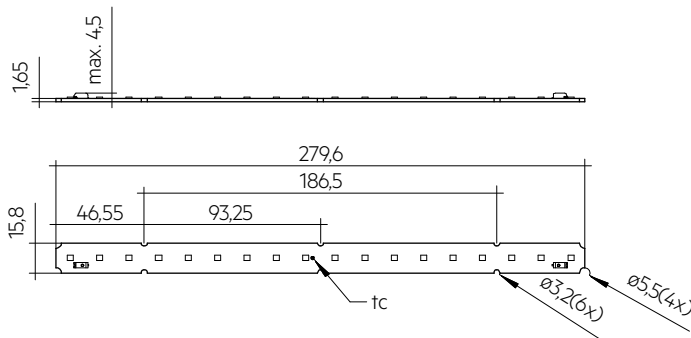

**LLE 16x280mm 650lm HV ADV5**

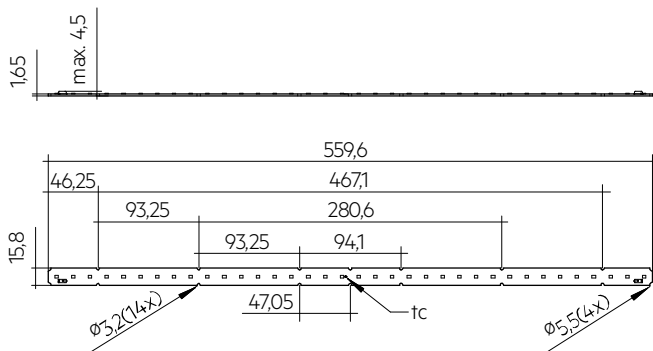

**LLE 16x560mm 1300lm HV ADV5**

**Ordering data**

Type	Article number	Article status	Colour temperature	Packaging, carton	Weight per pc.
LLE 16x140mm 325lm 927 HV ADV5	28003309	Standard	2,700 K	144 pc(s).	0.007 kg
LLE 16x140mm 325lm 930 HV ADV5	28003312	Standard	3,000 K	144 pc(s).	0.007 kg
LLE 16x140mm 325lm 935 HV ADV5	28003313	Standard	3,500 K	144 pc(s).	0.007 kg
LLE 16x140mm 325lm 940 HV ADV5	28003314	Standard	4,000 K	144 pc(s).	0.007 kg
LLE 16x280mm 650lm 927 HV ADV5	28003315	Standard	2,700 K	144 pc(s).	0.014 kg
LLE 16x280mm 650lm 930 HV ADV5	28003316	Standard	3,000 K	144 pc(s).	0.014 kg
LLE 16x280mm 650lm 935 HV ADV5	28003317	On demand	3,500 K	144 pc(s).	0.014 kg
LLE 16x280mm 650lm 940 HV ADV5	28003318	Standard	4,000 K	144 pc(s).	0.014 kg
LLE 16x560mm 1300lm 927 HV ADV5	28003997	On demand	2,700 K	144 pc(s).	0.028 kg
LLE 16x560mm 1300lm 930 HV ADV5	28003998	Standard	3,000 K	144 pc(s).	0.028 kg
LLE 16x560mm 1300lm 935 HV ADV5	28003999	On demand	3,500 K	144 pc(s).	0.028 kg
LLE 16x560mm 1300lm 940 HV ADV5	28004000	Standard	4,000 K	144 pc(s).	0.028 kg

**Technical data**

Beam characteristic	120°
Ambient temperature $t_a$	-40 ... +65 °C
$t_p$ rated	50 °C
$t_c$	85 °C
$I_{rated}$	225 mA
$I_{max}$	540 mA
Max. permissible LF current ripple	595 mA
Max. permissible peak current	900 mA / max. 8 ms
Max. working voltage for insulation <sup>®</sup>	400 V
Insulation test voltage	1.8 kV
CTI of the printed circuit board	≥ 600
Colour tolerance	3 SDCM
ESD classification	Severity level 4
Risk group (IEC 62471) at ≤ 470 mA	RG0
Risk group (IEC 62471) at $I_{max}$	RG1
Classification acc. to IEC 62031	Built-in
Type of protection	IP00
Lumen maintenance L70B50	72,000 h
Guarantee (conditions at <a href="http://www.tridonic.com">www.tridonic.com</a> )	5 Year(s)

**Approval marks****Standards**

IEC 62031, IEC 62471, IEC 61000-4-2, IEC 62778, IEC 61547, UL 8750

## Specific technical data

Type	Article number	Photometric code	Useful luminous flux at $t_p = 25^\circ\text{C}$ <sup>③</sup>	Expected luminous flux at $t_p$ rated <sup>④</sup>	Typ. forward current	Min. forward voltage at $t_p$ rated	Max. forward voltage at $t_p = 25^\circ\text{C}$	Power consumption $P_{on}$ at $t_p = 25^\circ\text{C}$ <sup>⑤</sup>	Efficacy of the module at $t_p = 25^\circ\text{C}$	Expected efficacy of the module at $t_p$ rated	Colour rendering index CRI
<b>Operating mode HE at 200 mA</b>											
LLE 16x140mm 325lm 927 HV ADV5	28003309	927/359	-	244 lm	200 mA	7.8 V	8.4 V	-	-	152 lm/W	>>90
LLE 16x140mm 325lm 930 HV ADV5	28003312	930/359	-	252 lm	200 mA	7.8 V	8.4 V	-	-	156 lm/W	>>90
LLE 16x140mm 325lm 935 HV ADV5	28003313	935/359	-	239 lm	200 mA	7.8 V	8.4 V	-	-	149 lm/W	>>90
LLE 16x140mm 325lm 940 HV ADV5	28003314	940/359	-	268 lm	200 mA	7.8 V	8.4 V	-	-	164 lm/W	>>90
LLE 16x280mm 650lm 927 HV ADV5	28003315	927/359	-	477 lm	200 mA	15.5 V	16.9 V	-	-	146 lm/W	>>90
LLE 16x280mm 650lm 930 HV ADV5	28003316	930/359	-	475 lm	200 mA	15.5 V	16.9 V	-	-	148 lm/W	>>90
LLE 16x280mm 650lm 935 HV ADV5	28003317	935/359	-	525 lm	200 mA	15.5 V	16.9 V	-	-	164 lm/W	>>90
LLE 16x280mm 650lm 940 HV ADV5	28003318	940/359	-	534 lm	200 mA	15.5 V	16.9 V	-	-	164 lm/W	>>90
LLE 16x560mm 1300lm 927 HV ADV5	28003997	927/359	-	954 lm	200 mA	30.7 V	34.0 V	-	-	147 lm/W	>>90
LLE 16x560mm 1300lm 930 HV ADV5	28003998	930/359	-	1,020 lm	200 mA	30.7 V	34.0 V	-	-	156 lm/W	>>90
LLE 16x560mm 1300lm 935 HV ADV5	28003999	935/359	-	1,054 lm	200 mA	30.7 V	34.0 V	-	-	162 lm/W	>>90
LLE 16x560mm 1300lm 940 HV ADV5	28004000	940/359	-	1,066 lm	200 mA	30.7 V	34.0 V	-	-	164 lm/W	>>90
<b>Operating mode NM at 225 mA</b>											
LLE 16x140mm 325lm 927 HV ADV5	28003309	927/359	277 lm	272 lm	225 mA	7.8 V	8.5 V	1.8 W	154 lm/W	150 lm/W	>>90
LLE 16x140mm 325lm 930 HV ADV5	28003312	930/359	285 lm	280 lm	225 mA	7.8 V	8.5 V	1.8 W	158 lm/W	155 lm/W	>>90
LLE 16x140mm 325lm 935 HV ADV5	28003313	935/359	275 lm	267 lm	225 mA	7.8 V	8.5 V	1.8 W	153 lm/W	148 lm/W	>>90
LLE 16x140mm 325lm 940 HV ADV5	28003314	940/359	307 lm	302 lm	225 mA	7.8 V	8.5 V	1.8 W	166 lm/W	162 lm/W	>>90
LLE 16x280mm 650lm 927 HV ADV5	28003315	927/359	547 lm	533 lm	225 mA	15.6 V	17.1 V	3.7 W	148 lm/W	144 lm/W	>>90
LLE 16x280mm 650lm 930 HV ADV5	28003316	930/359	545 lm	530 lm	225 mA	15.6 V	17.1 V	3.7 W	147 lm/W	143 lm/W	>>90
LLE 16x280mm 650lm 935 HV ADV5	28003317	935/359	604 lm	588 lm	225 mA	15.6 V	17.1 V	3.7 W	163 lm/W	159 lm/W	>>90
LLE 16x280mm 650lm 940 HV ADV5	28003318	940/359	612 lm	597 lm	225 mA	15.6 V	17.1 V	3.7 W	165 lm/W	163 lm/W	>>90
LLE 16x560mm 1300lm 927 HV ADV5	28003997	927/359	1,094 lm	1,064 lm	225 mA	30.8 V	34.2 V	7.4 W	148 lm/W	146 lm/W	>>90
LLE 16x560mm 1300lm 930 HV ADV5	28003998	930/359	1,164 lm	1,135 lm	225 mA	30.8 V	34.2 V	7.4 W	157 lm/W	154 lm/W	>>90
LLE 16x560mm 1300lm 935 HV ADV5	28003999	935/359	1,209 lm	1,176 lm	225 mA	30.8 V	34.2 V	7.4 W	163 lm/W	161 lm/W	>>90
LLE 16x560mm 1300lm 940 HV ADV5	28004000	940/359	1,221 lm	1,192 lm	225 mA	30.8 V	34.2 V	7.4 W	165 lm/W	162 lm/W	>>90
<b>Operating mode HO at 500 mA</b>											
LLE 16x140mm 325lm 927 HV ADV5	28003309	927/359	-	564 lm	500 mA	8.1 V	8.9 V	-	-	134 lm/W	>>90
LLE 16x140mm 325lm 930 HV ADV5	28003312	930/359	-	580 lm	500 mA	8.1 V	8.9 V	-	-	138 lm/W	>>90
LLE 16x140mm 325lm 935 HV ADV5	28003313	935/359	-	557 lm	500 mA	8.1 V	8.9 V	-	-	133 lm/W	>>90
LLE 16x140mm 325lm 940 HV ADV5	28003314	940/359	-	624 lm	500 mA	8.1 V	8.9 V	-	-	145 lm/W	>>90
LLE 16x280mm 650lm 927 HV ADV5	28003315	927/359	-	1,103 lm	500 mA	16.4 V	17.7 V	-	-	128 lm/W	>>90
LLE 16x280mm 650lm 930 HV ADV5	28003316	930/359	-	1,102 lm	500 mA	16.4 V	17.7 V	-	-	130 lm/W	>>90
LLE 16x280mm 650lm 935 HV ADV5	28003317	935/359	-	1,220 lm	500 mA	16.4 V	17.7 V	-	-	144 lm/W	>>90
LLE 16x280mm 650lm 940 HV ADV5	28003318	940/359	-	1,243 lm	500 mA	16.4 V	17.7 V	-	-	145 lm/W	>>90
LLE 16x560mm 1300lm 927 HV ADV5	28003997	927/359	-	2,213 lm	500 mA	32.3 V	35.7 V	-	-	129 lm/W	>>90
LLE 16x560mm 1300lm 930 HV ADV5	28003998	930/359	-	2,357 lm	500 mA	32.3 V	35.7 V	-	-	138 lm/W	>>90
LLE 16x560mm 1300lm 935 HV ADV5	28003999	935/359	-	2,445 lm	500 mA	32.3 V	35.7 V	-	-	143 lm/W	>>90
LLE 16x560mm 1300lm 940 HV ADV5	28004000	940/359	-	2,481 lm	500 mA	32.3 V	35.7 V	-	-	145 lm/W	>>90

② If mounted with M3 screws and plastic washers.

③ Tolerance of useful light flux - 0 % / + 15 %. Measurement uncertainty  $\pm 10\%$ .

④ Tolerance of expected light flux - 0 % / + 15 %. Measurement uncertainty  $\pm 10\%$ . Based on calculation.

⑤ Tolerance of power consumption  $P_{on}$   $\pm 10\%$ . Measurement uncertainty  $\pm 5\%$ .

## ACL BRIDGE LLE16

Accessory

**Product description**

- \_ Clip for fixation for LLE16
- \_ Fast snap on mounting (for sheet thickness 0.5 – 1.0 mm)
- \_ For drilling hole 3 mm
- \_ Clip made of polycarbonate
- \_ Minimum sales quantity 200 pcs.

**Website**

<http://www.tridonic.com/28001035>

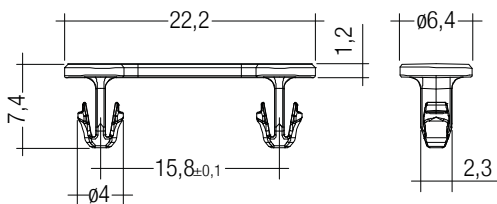
**Ordering data**

Type	Article number	Colour	Packaging, bag	Weight per pc.
ACL BRIDGE LLE16 PUSH-FIX	28001035	White	200 pc(s).	0.001 kg

## ACL LINEAR COVER 16mm

Accessory

**Product description**

- \_ LINEAR COVER for LLE 16
- \_ Protection against direct touch for non-SELV applications (recommendation: use all fixing points) <sup>①</sup>
- \_ Fast snap on mounting on to LLE 16 with clips or plastic washers
- \_ High transmission: transparent, semi-transparent and diffuse
- \_ Linear lense made of PMMA
- \_ Tolerances LINEAR COVER: + 10 mm for 1,600 / 1,200 mm length (ends raw)

① Ends must be covered by the luminaire construction.

**Website**

<http://www.tridonic.com/28000950>

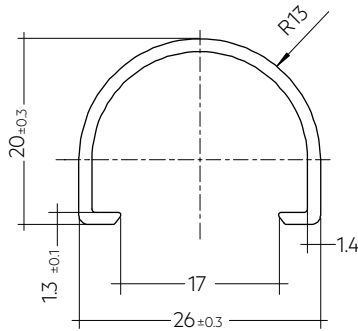
**Ordering data**

Type	Article number	Colour	Length L	Packaging, carton	Weight per pc.
ACL LINEAR COVER 16x1600mm FROSTED	28000950	Semi-transparent	1,600 mm	24 pc(s).	0.147 kg
ACL LINEAR COVER 16x1200mm FROSTED	28002827	Semi-transparent	1,200 mm	24 pc(s).	0.100 kg
ACL LINEAR COVER 16x1600mm DIFFUSE	28000951	Diffuse	1,600 mm	24 pc(s).	0.147 kg
ACL LINEAR COVER 16x1200mm DIFFUSE	28002828	Diffuse	1,200 mm	24 pc(s).	0.100 kg

## 1. Standards

IEC 62031  
 IEC 62471  
 IEC 61000-4-2  
 IEC 62778  
 IEC 61547  
 UL 8750 (for CLASS2 circuits and dry locations)

### 1.1 Photometric code

Key for photometric code, e. g. 830 / 349

1 <sup>st</sup> digit	2 <sup>nd</sup> + 3 <sup>rd</sup> digit	4 <sup>th</sup> digit	5 <sup>th</sup> digit	6 <sup>th</sup> digit	
Code	CRI	Colour temperature in Kelvin x 100	MacAdam initial	MacAdam after 25% of the lifetime (max.6000h)	
7	70 – 79			Luminous flux after 25% of the lifetime (max.6000h)	
8	80 – 89			Code	Luminous flux
9	≥90			7	≥ 70 %
				8	≥ 80 %
				9	≥ 90 %

### 1.2 Energy classification

Type	Colour temperature	Forward current	Energy classification	Energy consumption
LLE 16x140mm 325lm 927 HV ADV5	2,700 K	225 mA	D	2 kWh / 1,000 h
LLE 16x140mm 325lm 930 HV ADV5	3,000 K	225 mA	D	2 kWh / 1,000 h
LLE 16x140mm 325lm 935 HV ADV5	3,500 K	225 mA	D	2 kWh / 1,000 h
LLE 16x140mm 325lm 940 HV ADV5	4,000 K	225 mA	D	2 kWh / 1,000 h
LLE 16x280mm 650lm 927 HV ADV5	2,700 K	225 mA	D	4 kWh / 1,000 h
LLE 16x280mm 650lm 930 HV ADV5	3,000 K	225 mA	D	4 kWh / 1,000 h
LLE 16x280mm 650lm 935 HV ADV5	3,500 K	225 mA	D	4 kWh / 1,000 h
LLE 16x280mm 650lm 940 HV ADV5	4,000 K	225 mA	D	4 kWh / 1,000 h
LLE 16x560mm 1300lm 927 HV ADV5	2,700 K	225 mA	D	8 kWh / 1,000 h
LLE 16x560mm 1300lm 930 HV ADV5	3,000 K	225 mA	D	8 kWh / 1,000 h
LLE 16x560mm 1300lm 935 HV ADV5	3,500 K	225 mA	D	8 kWh / 1,000 h
LLE 16x560mm 1300lm 940 HV ADV5	4,000 K	225 mA	D	8 kWh / 1,000 h

Energy label and further information at [www.tridonic.com](http://www.tridonic.com) in the certificates tab of the corresponding product page and at the EPREL data base <https://eprel.ec.europa.eu/>

## 2. Thermal details

### 2.1 tc point, ambient temperature and lifetime

The temperature at tp reference point is crucial for the light output and lifetime of a LED product.

For LLE a tp temperature of 50 °C has to be complied in order to achieve an optimum between heat sink requirements, light output and lifetime.

Compliance with the maximum permissible reference temperature at the tc point must be checked under operating conditions in a thermally stable state. The maximum value must be determined under worst-case conditions for the relevant application.

The tc and tp temperature of LED modules from Tridonic are measured at the same reference point.

### 2.2 Storage and humidity

Storage temperature	-40...+85 °C
---------------------	--------------

Operation only in non condensing environment.

Humidity during processing of the module should be between 30 to 70 %.

## 2.3 Heat sink values

### LLE 16x140mm 325lm ADV5

ta	tp	Forward current	R <sub>th, hs-a</sub>	Cooling area
25 °C	50 °C	225 mA		self cooling
25 °C	50 °C	500 mA		self cooling
35 °C	50 °C	225 mA	16.59 K/W	40 cm <sup>2</sup>
35 °C	50 °C	500 mA	6.36 K/W	105 cm <sup>2</sup>
40 °C	50 °C	225 mA	11.05 K/W	60 cm <sup>2</sup>
40 °C	50 °C	500 mA	4.23 K/W	157 cm <sup>2</sup>
45 °C	50 °C	225 mA	5.51 K/W	121 cm <sup>2</sup>
45 °C	50 °C	500 mA	2.11 K/W	316 cm <sup>2</sup>

### LLE 16x280mm 650lm ADV5

ta	tp	Forward current	R <sub>th, hs-a</sub>	Cooling area
25 °C	50 °C	225 mA		self cooling
25 °C	50 °C	500 mA		self cooling
35 °C	50 °C	225 mA	8.58 K/W	78 cm <sup>2</sup>
35 °C	50 °C	500 mA	3.29 K/W	203 cm <sup>2</sup>
40 °C	50 °C	225 mA	5.72 K/W	117 cm <sup>2</sup>
40 °C	50 °C	500 mA	2.19 K/W	305 cm <sup>2</sup>
45 °C	50 °C	225 mA	2.85 K/W	234 cm <sup>2</sup>
45 °C	50 °C	500 mA	1.09 K/W	613 cm <sup>2</sup>

### LLE 16x560mm 1300lm ADV5

ta	tp	Forward current	R <sub>th, hs-a</sub>	Cooling area
25 °C	50 °C	225 mA		self cooling
25 °C	50 °C	500 mA		self cooling
35 °C	50 °C	225 mA	4.56 K/W	146 cm <sup>2</sup>
35 °C	50 °C	500 mA	1.74 K/W	384 cm <sup>2</sup>
40 °C	50 °C	225 mA	3.04 K/W	219 cm <sup>2</sup>
40 °C	50 °C	500 mA	1.16 K/W	576 cm <sup>2</sup>
45 °C	50 °C	225 mA	1.52 K/W	439 cm <sup>2</sup>
45 °C	50 °C	500 mA	0.58 K/W	1,157 cm <sup>2</sup>

### Notes

The actual cooling surface can differ because of the material, the structural shape, outside influences and the installation situation. Depending on the heat sink a heat conducting paste or heat conducting film might be necessary to keep the specified tp temperature.

### 3. Installation / wiring

#### 3.1 Electrical supply/choice of LED driver

LLE modules from Tridonic are not protected against overvoltages, overcurrents, overloads or short-circuit currents. Safe and reliable operation can only be guaranteed in conjunction with a LED driver which complies with the relevant standards. The use of LED driver from Tridonic in combination with LLE modules guarantees the necessary protection for safe and reliable operation.

If a LED driver other than Tridonic is used, it must provide the following protection:

- Short-circuit protection
- Overload protection
- Overtemperature protection



LLE modules must be supplied by a constant current LED driver. Operation with a constant voltage LED driver will lead to an irreversible damage of the module.

Wrong polarity can damage the LLE.

The LLE module is designed for serial wiring.

With parallel wiring tolerance-related differences in output are possible (thermal stress of the module) and can cause differences in brightness.

If a wire breaks or a complete module fails then the current passing through the other module increases. This may reduce its life considerably.

The max. permissible output current of the LED driver for parallel wiring is 1,080 mA.

Parallel wiring is only permitted with 280 or 560 mm modules.

LLE can be operated either from SELV LED drivers or from LED drivers with LV output voltage.



LLE are basic insulated up to 400 V (if mounted with M3 screws with head diameter 7 mm in combination with plastic washers) against ground and can be mounted directly on earthed metal parts of the luminaire. If the max. output voltage of the LED driver (also against earth) is above 400 V, an additional insulation between LED module and heat sink is required (for example by insulated thermal pads) or by a suitable luminaire construction.

At voltages > 60 V an additional protection against direct touch (test finger) to the light emitting side of the module has to be guaranteed. This is typically achieved by means of a non removable light distributor over the module.

#### 3.2 Wiring



#### Wiring examples for serial wiring

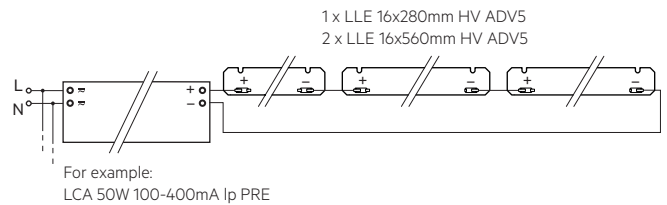
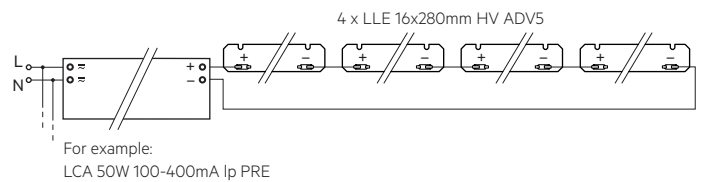

#### Wiring examples for parallel wiring

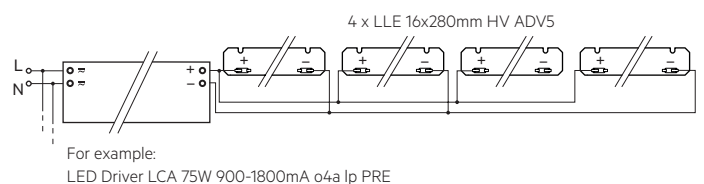

#### 3.3 Wiring type and cross section

For wiring use solid wire from 0.14 to 0.5 mm<sup>2</sup>.

No reconnection with smaller diameters possible if used with >0.34 mm<sup>2</sup>.

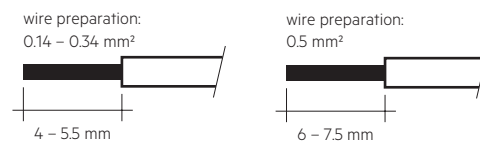

To remove the wires use a suitabel tool (Wago 206-859) or through twist and pull.

#### 3.4 Mounting instruction



None of the components of the LLE (substrate, LED, electronic components etc.) may be exposed to tensile or compressive stresses.

Max. torque for fixing: 0.5 Nm.

The LED modules are mounted onto a heat sink with min. 6 M3 screws with plastic washers per module or ACL BRIDGE LLE16 PUSH-FIX.



Chemical substance may harm the LED module. Chemical reactions could lead to colour shift, reduced luminous flux or a total failure of the module caused by corrosion of electrical connections.

Materials which are used in LED applications (e.g. sealings, adhesives) must not produce dissolver gas. They must not be condensation curing based, acetate curing based or contain sulfur, chlorine or phthalate.

Avoid corrosive atmosphere during usage and storage.

### 3.5 EOS/ESD safety guidelines



The device / module contains components that are sensitive to electrostatic discharge and may only be installed in the factory and on site if appropriate EOS/ESD protection measures have been taken. No special measures need be taken for devices/modules with enclosed casings (contact with the pc board not possible), just normal installation practice. Please note the requirements set out in the document EOS / ESD guidelines (Guideline\_EOS\_ESD.pdf) at: <http://www.tridonic.com/esd-protection>

## 4. Lifetime

### 4.1 Lifetime, lumen maintenance and failure rate

The light output of an LED module decreases over the lifetime, this is characterized with the L value.

L70 means that the LED module will give 70 % of its initial luminous flux.

This value is always related to the number of operation hours and therefore defines the lifetime of an LED module.

As the L value is a statistical value and the lumen maintenance may vary over the delivered LED modules.

The B value defines the amount of modules which are below the specific L value, e.g. L70B10 means 10 % of the LED modules are below 70 % of the initial luminous flux, respectively 90 % will be above 70 % of the initial value.

In addition the percentage of failed modules (fatal failure) is characterized by the C value.

The F value is the combination of the B and C value. That means for F degradation and complete failures are considered, e.g. L70F10 means 10 % of the LED modules may fail or be below 70 % of the initial luminous flux.

### 4.2 Lumen maintenance for LLE 16mm HV ADV5

Forward current	tp tempera- ture	tp						
		L90 / F10	L90 / F50	L80 / F10	L80 / F50	L70 / F10	L70 / F50	
150 mA	40 °C	43,000 h	59,000 h	>72,000 h	>72,000 h	>72,000 h	>72,000 h	
	45 °C	42,000 h	57,000 h	>72,000 h	>72,000 h	>72,000 h	>72,000 h	
	50 °C	41,000 h	55,000 h	>72,000 h	>72,000 h	>72,000 h	>72,000 h	
	55 °C	40,000 h	54,000 h	>72,000 h	>72,000 h	>72,000 h	>72,000 h	
	60 °C	39,000 h	52,000 h	>72,000 h	>72,000 h	>72,000 h	>72,000 h	
	65 °C	38,000 h	50,000 h	>72,000 h	>72,000 h	>72,000 h	>72,000 h	
	70 °C	38,000 h	49,000 h	>72,000 h	>72,000 h	>72,000 h	>72,000 h	
	75 °C	37,000 h	47,000 h	>72,000 h	>72,000 h	>72,000 h	>72,000 h	
	80 °C	36,000 h	46,000 h	>72,000 h	>72,000 h	>72,000 h	>72,000 h	
	85 °C	35,000 h	45,000 h	>72,000 h	>72,000 h	>72,000 h	>72,000 h	
	200 mA	40 °C	43,000 h	58,000 h	>72,000 h	>72,000 h	>72,000 h	>72,000 h
		45 °C	42,000 h	57,000 h	>72,000 h	>72,000 h	>72,000 h	>72,000 h
		50 °C	41,000 h	55,000 h	>72,000 h	>72,000 h	>72,000 h	>72,000 h
		55 °C	40,000 h	53,000 h	>72,000 h	>72,000 h	>72,000 h	>72,000 h
		60 °C	39,000 h	51,000 h	>72,000 h	>72,000 h	>72,000 h	>72,000 h
65 °C		38,000 h	50,000 h	>72,000 h	>72,000 h	>72,000 h	>72,000 h	
70 °C		37,000 h	48,000 h	>72,000 h	>72,000 h	>72,000 h	>72,000 h	
75 °C		36,000 h	47,000 h	>72,000 h	>72,000 h	>72,000 h	>72,000 h	
80 °C		36,000 h	45,000 h	>72,000 h	>72,000 h	>72,000 h	>72,000 h	
85 °C		35,000 h	44,000 h	>72,000 h	>72,000 h	>72,000 h	>72,000 h	
300 mA		40 °C	42,000 h	58,000 h	>72,000 h	>72,000 h	>72,000 h	>72,000 h
		45 °C	41,000 h	56,000 h	>72,000 h	>72,000 h	>72,000 h	>72,000 h
		50 °C	40,000 h	54,000 h	>72,000 h	>72,000 h	>72,000 h	>72,000 h
		55 °C	40,000 h	52,000 h	>72,000 h	>72,000 h	>72,000 h	>72,000 h
		60 °C	39,000 h	51,000 h	>72,000 h	>72,000 h	>72,000 h	>72,000 h
	65 °C	38,000 h	49,000 h	>72,000 h	>72,000 h	>72,000 h	>72,000 h	
	70 °C	37,000 h	48,000 h	>72,000 h	>72,000 h	>72,000 h	>72,000 h	
	75 °C	36,000 h	46,000 h	>72,000 h	>72,000 h	>72,000 h	>72,000 h	
	80 °C	35,000 h	45,000 h	>72,000 h	>72,000 h	>72,000 h	>72,000 h	
	85 °C	34,000 h	44,000 h	70,000 h	>72,000 h	>72,000 h	>72,000 h	

Forward current	tp tempera- ture	tp						
		L90 / F10	L90 / F50	L80 / F10	L80 / F50	L70 / F10	L70 / F50	
375 mA	40 °C	42,000 h	57,000 h	>72,000 h	>72,000 h	>72,000 h	>72,000 h	
	45 °C	41,000 h	55,000 h	>72,000 h	>72,000 h	>72,000 h	>72,000 h	
	50 °C	40,000 h	54,000 h	>72,000 h	>72,000 h	>72,000 h	>72,000 h	
	55 °C	39,000 h	52,000 h	>72,000 h	>72,000 h	>72,000 h	>72,000 h	
	60 °C	38,000 h	50,000 h	>72,000 h	>72,000 h	>72,000 h	>72,000 h	
	65 °C	37,000 h	49,000 h	>72,000 h	>72,000 h	>72,000 h	>72,000 h	
	70 °C	37,000 h	47,000 h	>72,000 h	>72,000 h	>72,000 h	>72,000 h	
	75 °C	36,000 h	46,000 h	>72,000 h	>72,000 h	>72,000 h	>72,000 h	
	80 °C	35,000 h	44,000 h	71,000 h	>72,000 h	>72,000 h	>72,000 h	
	85 °C	34,000 h	43,000 h	69,000 h	>72,000 h	>72,000 h	>72,000 h	
	450 mA	40 °C	42,000 h	56,000 h	>72,000 h	>72,000 h	>72,000 h	>72,000 h
		45 °C	41,000 h	55,000 h	>72,000 h	>72,000 h	>72,000 h	>72,000 h
		50 °C	40,000 h	53,000 h	>72,000 h	>72,000 h	>72,000 h	>72,000 h
		55 °C	39,000 h	51,000 h	>72,000 h	>72,000 h	>72,000 h	>72,000 h
		60 °C	38,000 h	50,000 h	>72,000 h	>72,000 h	>72,000 h	>72,000 h
65 °C		37,000 h	48,000 h	>72,000 h	>72,000 h	>72,000 h	>72,000 h	
70 °C		36,000 h	47,000 h	>72,000 h	>72,000 h	>72,000 h	>72,000 h	
75 °C		35,000 h	45,000 h	>72,000 h	>72,000 h	>72,000 h	>72,000 h	
80 °C		35,000 h	44,000 h	70,000 h	>72,000 h	>72,000 h	>72,000 h	
85 °C		34,000 h	43,000 h	69,000 h	>72,000 h	>72,000 h	>72,000 h	
500 mA		40 °C	41,000 h	56,000 h	>72,000 h	>72,000 h	>72,000 h	>72,000 h
		45 °C	40,000 h	54,000 h	>72,000 h	>72,000 h	>72,000 h	>72,000 h
		50 °C	39,000 h	52,000 h	>72,000 h	>72,000 h	>72,000 h	>72,000 h
		55 °C	38,000 h	51,000 h	>72,000 h	>72,000 h	>72,000 h	>72,000 h
		60 °C	38,000 h	49,000 h	>72,000 h	>72,000 h	>72,000 h	>72,000 h
	65 °C	37,000 h	48,000 h	>72,000 h	>72,000 h	>72,000 h	>72,000 h	
	70 °C	36,000 h	46,000 h	>72,000 h	>72,000 h	>72,000 h	>72,000 h	
	75 °C	35,000 h	45,000 h	71,000 h	>72,000 h	>72,000 h	>72,000 h	
	80 °C	34,000 h	43,000 h	70,000 h	>72,000 h	>72,000 h	>72,000 h	
	85 °C	34,000 h	42,000 h	68,000 h	>72,000 h	>72,000 h	>72,000 h	

### 4.3 Switching capability

100,000 cycles

Tridonic test according to IEC 62717 Cl 10.3.3  
30 s on / 30 s off at I<sub>max</sub>

## 5. Electrical values

### 5.1 Declaration of electrical parameters

Irated ... Nominal operating current the module is designed for.

I<sub>max</sub> ... Max. permissible continuous operating current incl. The tolerances of the LED driver.

Max. permissible LF current ripple ... Max. output current of the LED driver incl. Tolerances and LF current ripple must not exceed this value.

Max. permissible peak current ... The max. output peak current of the LED driver must not exceed this value.

### 5.2 Typ. forward voltage vs. forward current

LLE 16x140mm 325lm 9xx HV ADV5

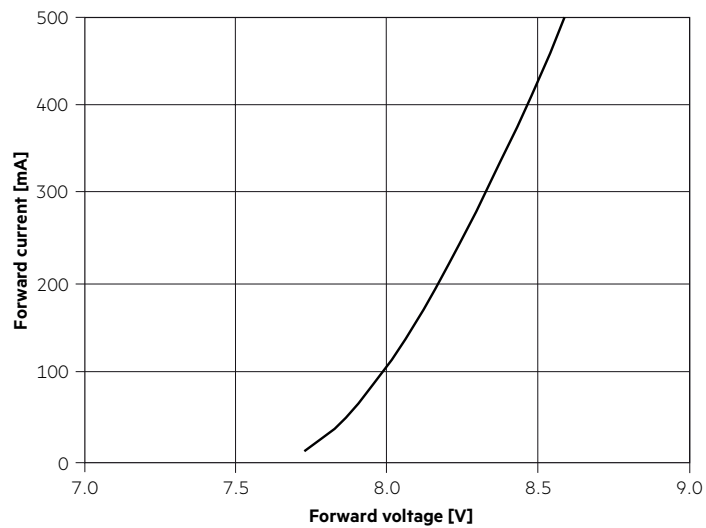

LLE 16x280mm 650lm 9xx HV ADV5

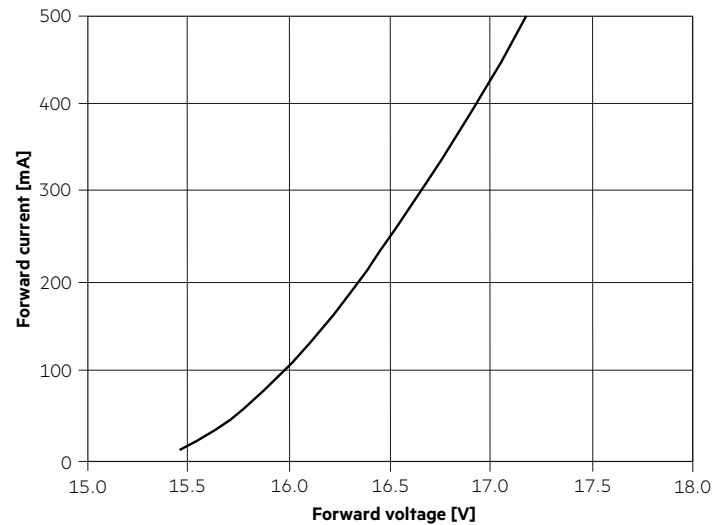

LLE 16x560mm 1300lm 9xx HV ADV5

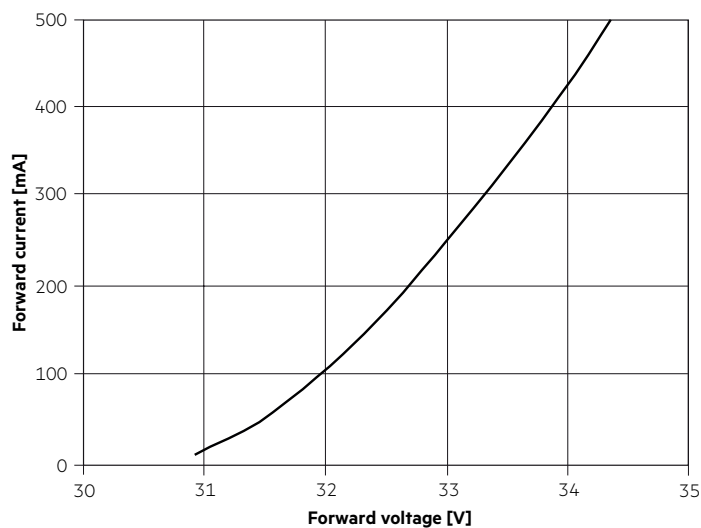

### 5.3 Forward voltage vs. tc temperature

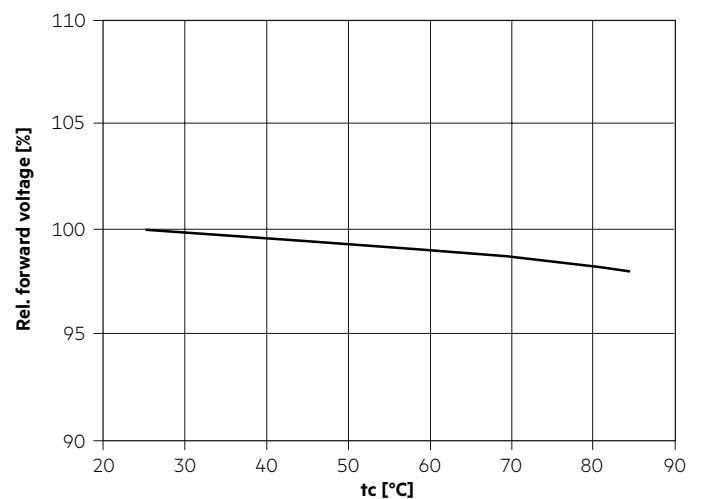

The diagrams are based on statistic values.  
The real values can be different.

## 6. Photometric characteristics

### 6.1 Coordinates and tolerances according to CIE 1931

The specified colour coordinates are integral measured by current impulse of 195 mA and a duration of 100 ms.  
 The ambient temperature of the measurement is  $t_a = 25^\circ\text{C}$ .  
 The measurement tolerance of the colour coordinates are  $\pm 0.01$ .

#### 2,700 K

	x0	y0
Centre	0.4578	0.4101

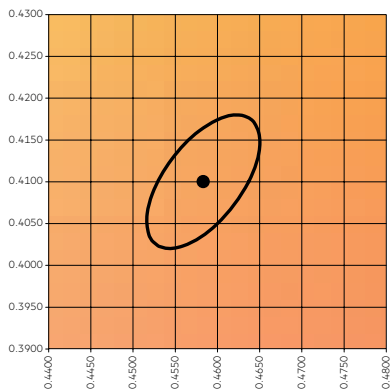

— MacAdam Ellipse: 3SDCM

TM30		CRI	
Rf	Rg	Ra	R9
91	99	93	57

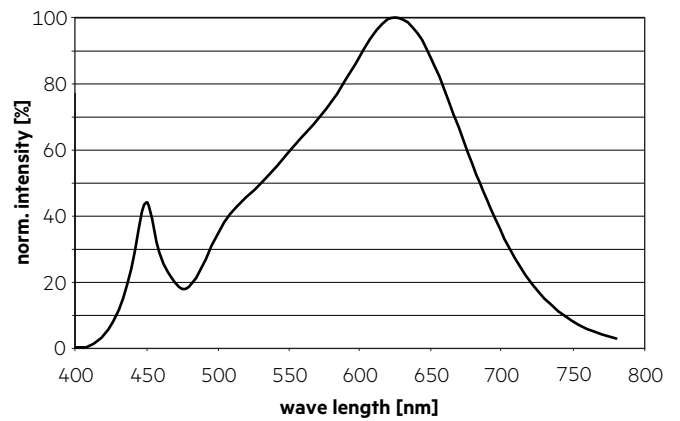

#### Colour vector graphic

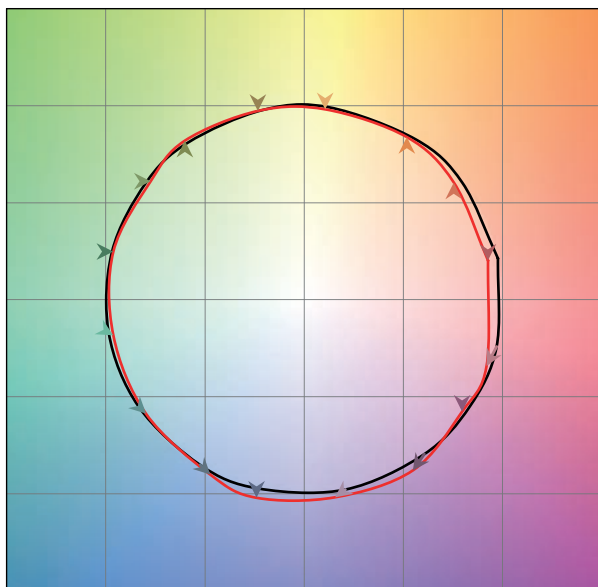

— Reference source  
 — Test source

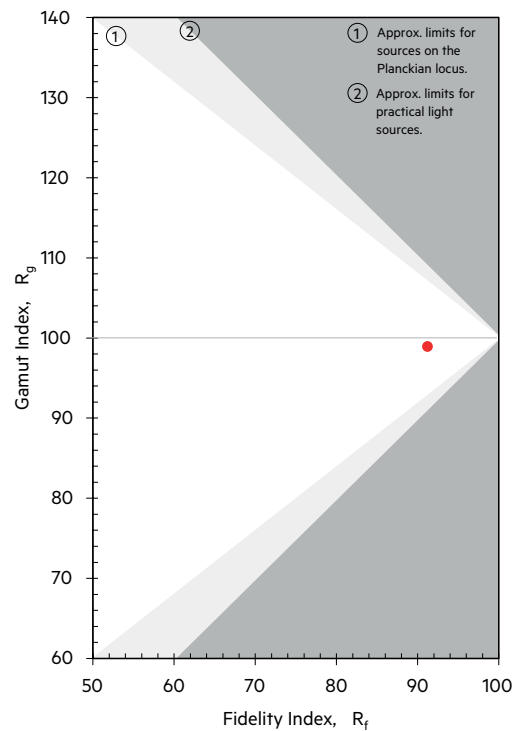

3,000 K

	x0	y0
Centre	0.4338	0.4030

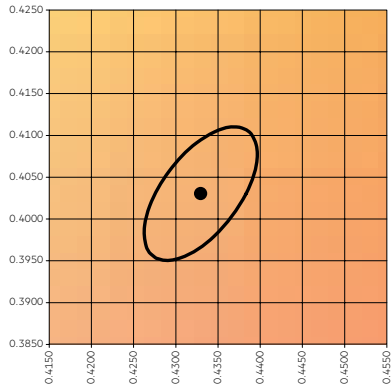

— MacAdam Ellipse: 3SDCM

TM30		CRI	
Rf	Rg	Ra	R9
90	98	92	57

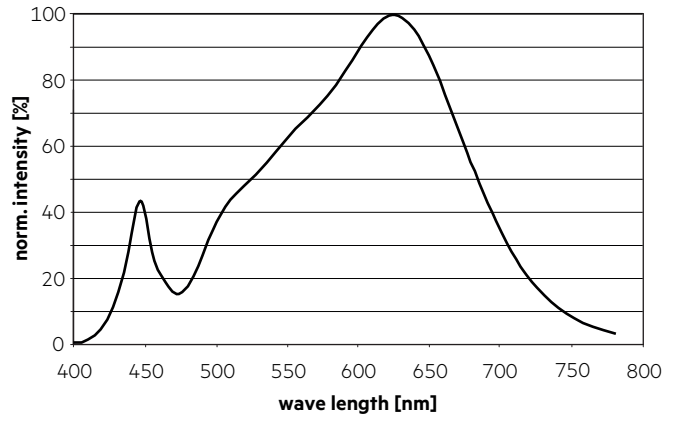

Colour vector graphic

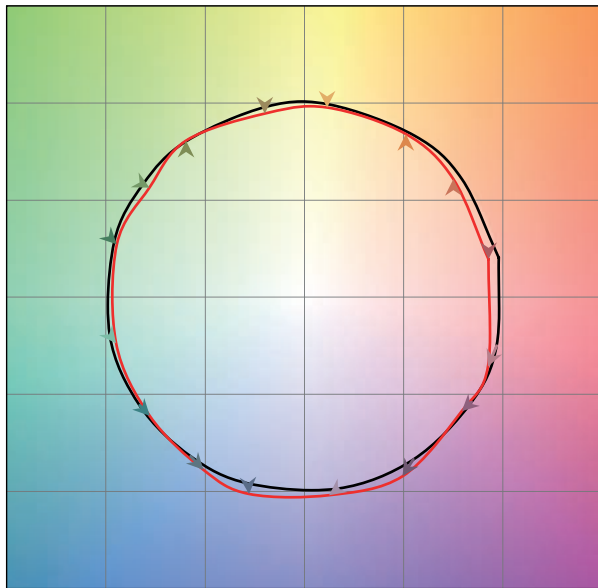

— Reference source  
— Test source

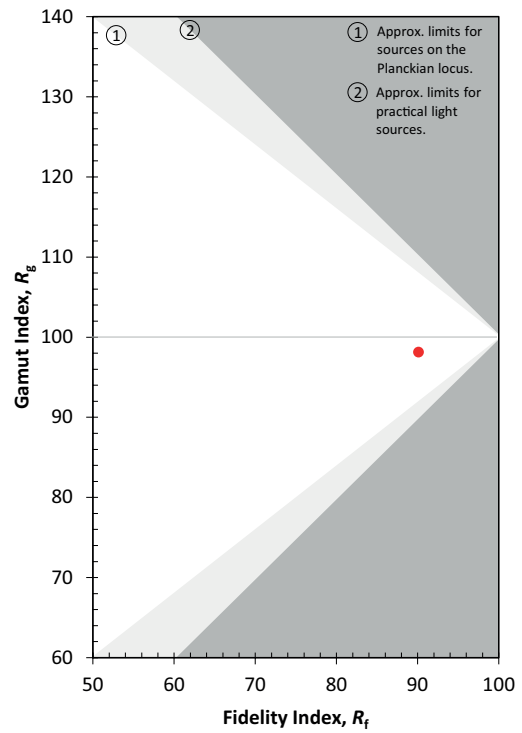

3,500 K

	x0	y0
Centre	0.4073	0.3917

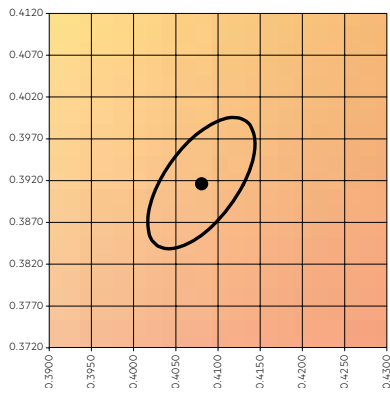

TM30		CRI	
Rf	Rg	Ra	R9
90	99	93	63

Colour vector graphic

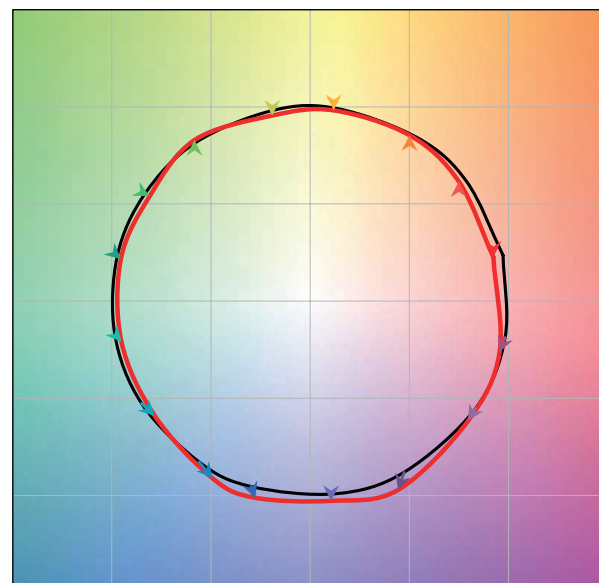

— Reference source  
— Test source

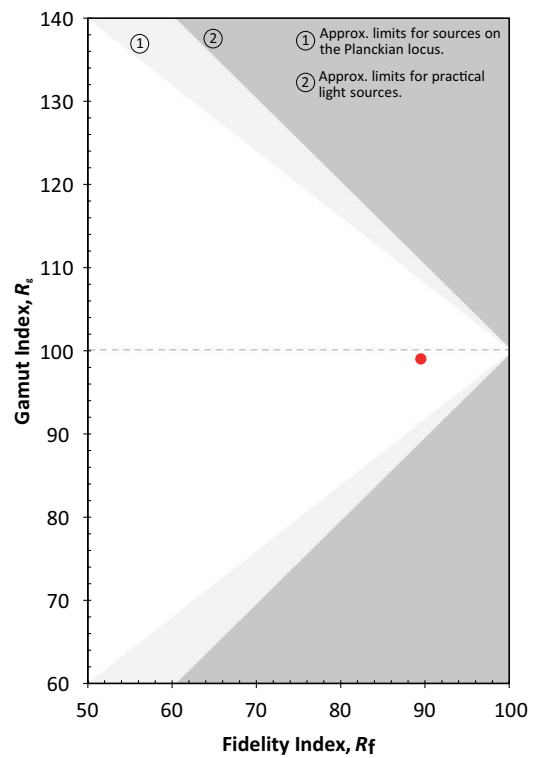
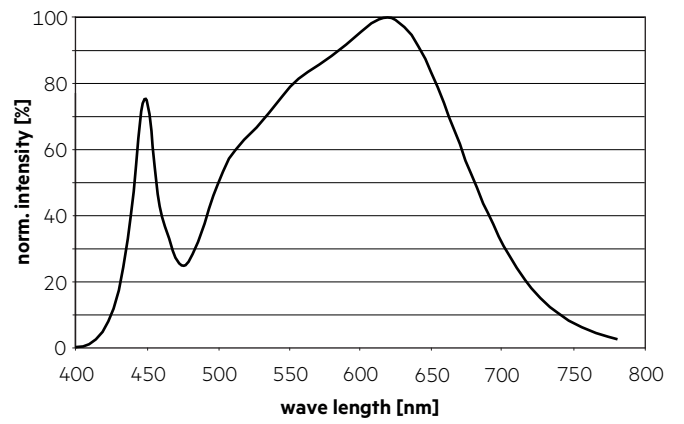

4,000 K

	x0	y0
Center	0.3818	0.3797

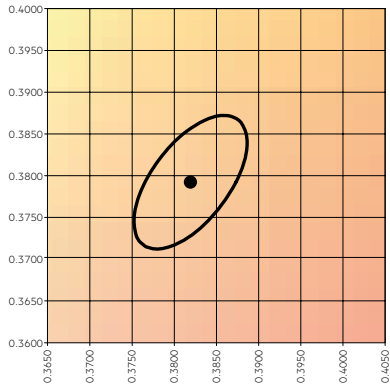

— MacAdam Ellipse: 3SDCM

TM30		CRI	
Rf	Rg	Ra	R9
89	99	91	54

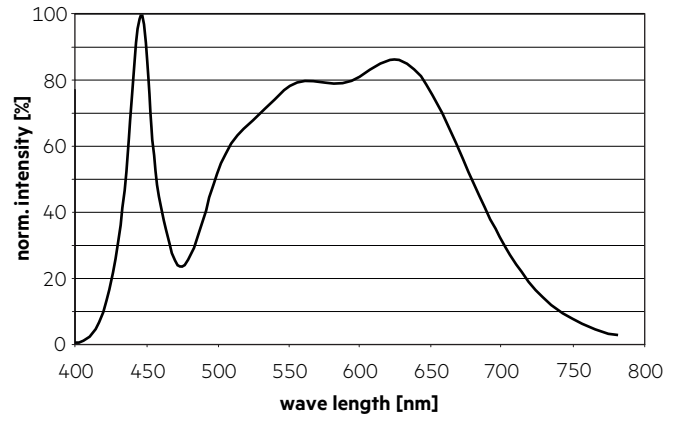

Colour vector graphic

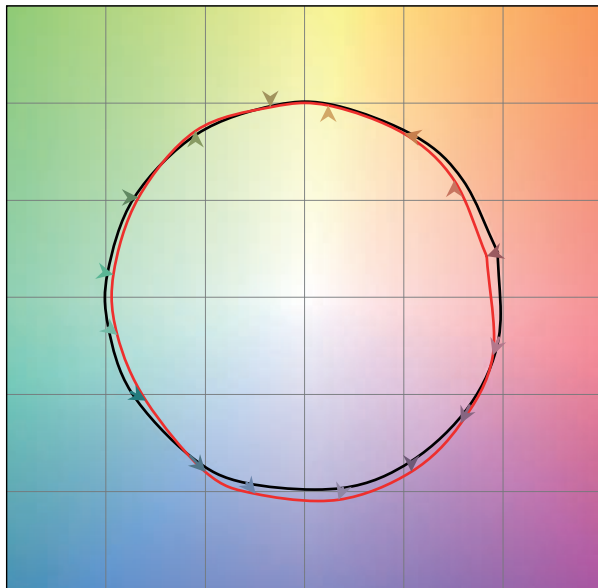

— Reference source  
— Test source

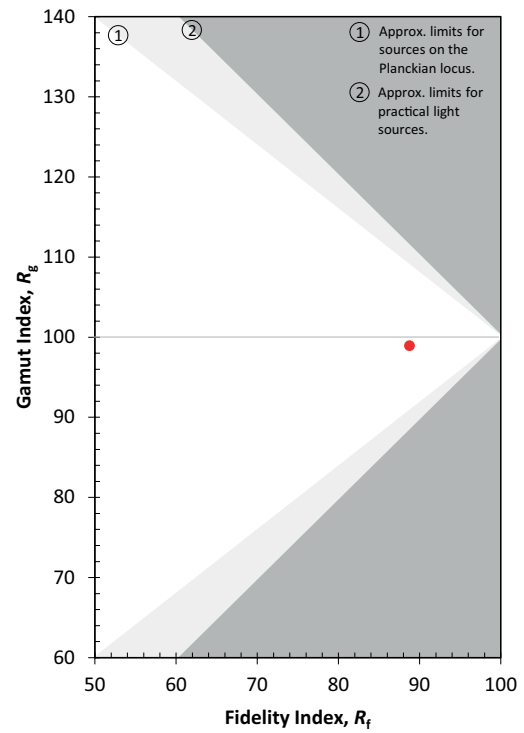

## 6.2 Light distribution

The optical design of the LLE product line ensures optimum homogeneity for the light distribution.

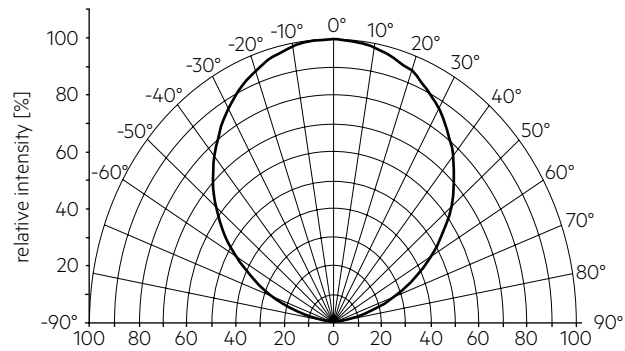

The colour temperature is measured integral over the complete module. The single LED light points can have deviations in the colour coordinates within MacAdam 5.

To ensure an ideal mixture of colours and a homogeneous light distribution a suitable optic (e. g. PMMA diffuser) and a sufficient spacing between module and optic (typ. 4 cm) should be used.

## 6.3 Relative luminous flux vs. tc temperature

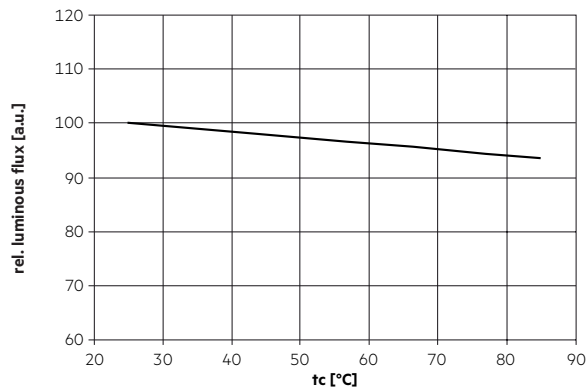

## 6.4 Relative luminous flux vs. operating current

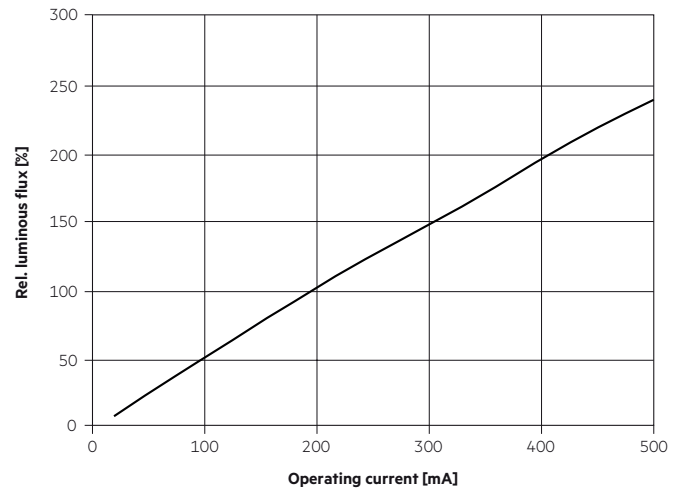

The diagrams are based on statistic values.  
The real values can be different.

## 7. Miscellaneous

### 7.1 Additional information

Additional technical information at [www.tridonic.com](http://www.tridonic.com) → Technical Data

Lifetime declarations are informative and represent no warranty claim.