

Module LLE 16mm 2000lm HV ADV6

Modules LLE advanced



LLE 16x280mm 2000lm HV ADV6



LLE 16x560mm 4000lm HV ADV6



For articles manufactured at Tridonic SRB d.o.o.

Product description

- _ Ideal for compact linear luminaire designs
- _ Homogenous illumination thanks to small package distance
- _ 2 terminals for serial wiring
- _ Perfectly uniform light, even if several LED modules are used together in a line
- _ Push terminals for quick and simple wiring of LED module to LED module
- _ HE ... High Efficiency, NM ... Nominal Mode, HO ... High Output
- _ Long lifetime up to 102,000 hours
- _ 5 years guarantee (Conditions at <https://www.tridonic.com/en/int/services/manufacturer-guarantee-conditions>)

Optical properties

- _ Colour temperatures 3,000 and 4,000 K
- _ Efficacy of the LED module 203 lm/W at Irated and tp = 25 °C
- _ High colour rendering index CRI > 80
- _ High colour consistency (MacAdam 3) ①
- _ Small luminous flux tolerances

Mechanical properties

- _ Module dimension 16 x 280 mm and 16 x 560 mm
- _ Simple installation via clips or screws

System solution

- _ Integrate compatible partner products into your final system solution: <https://www.tridonic.com/en/int/products/accessories#partner>
- _ Combine Tridonic's LED modules and dimmable drivers to achieve an outstanding system efficacy (configuration possible via <https://setbuilder.tridonic.com/>)

① Integral measurement over the complete module.

Website

<http://www.tridonic.com/28005020>

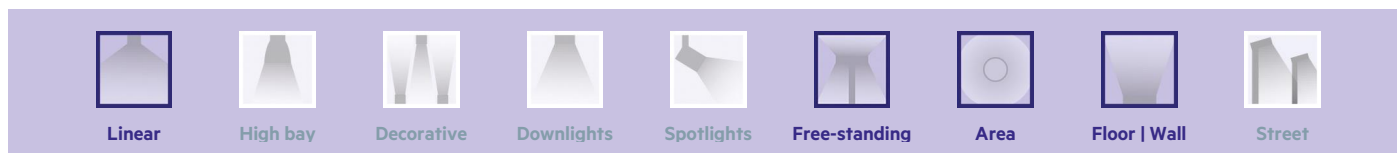
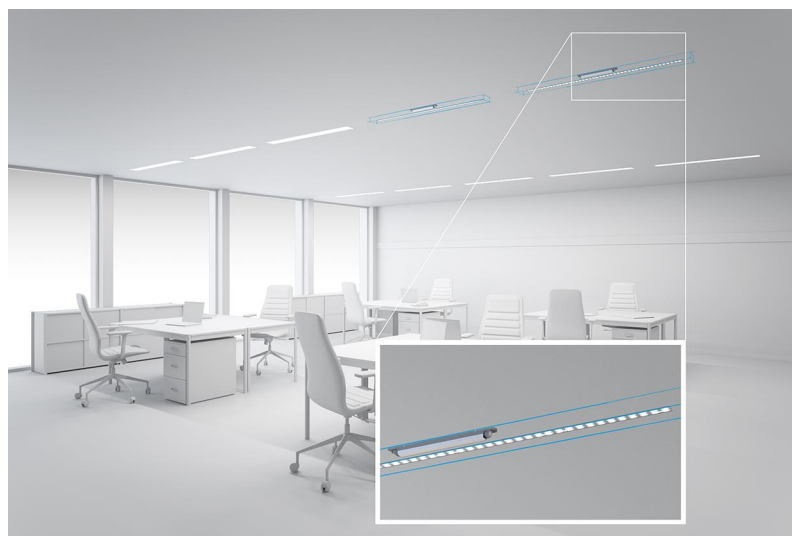

Module LLE 16mm 2000lm HV ADV6

Modules LLE advanced

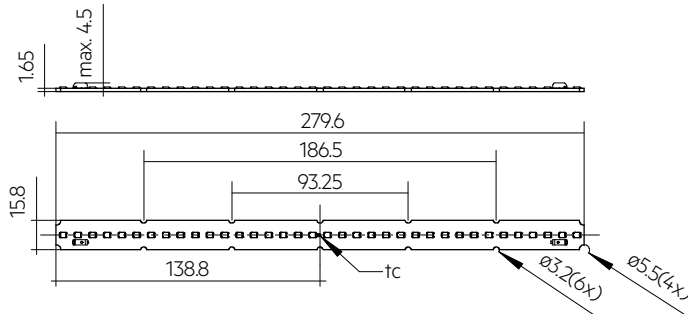

LLE 16x280mm 2000lm HV ADV6

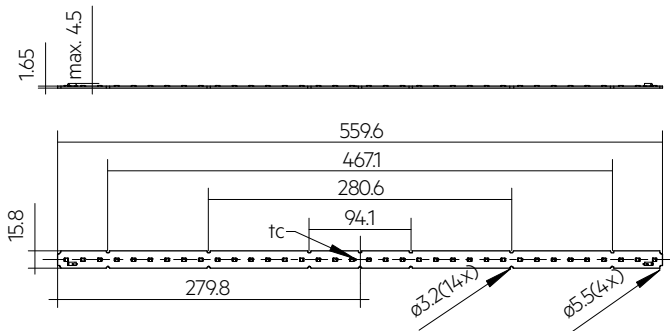

LLE 16x560mm 4000lm HV ADV6

Ordering data

Type	Article number	Colour temperature	Packaging, carton	Weight per pc.
LLE 16x280mm 2000lm 830 HV ADV6	28005020	3,000 K	144 pc(s).	0.014 kg
LLE 16x280mm 2000lm 840 HV ADV6	28005021	4,000 K	144 pc(s).	0.014 kg
LLE 16x560mm 4000lm 830 HV ADV6	28005022	3,000 K	144 pc(s).	0.028 kg
LLE 16x560mm 4000lm 840 HV ADV6	28005023	4,000 K	144 pc(s).	0.028 kg

Technical data

Beam characteristic	360°
Ambient temperature t_a	-40 ... +65 °C
t_p rated	50 °C
t_c	95 °C
I _{rated}	300 mA
I _{max}	600 mA
Max. permissible LF current ripple	700 mA
Max. permissible peak current	1,350 mA / max. 10 ms
Max. working voltage for insulation [®]	320 V
Insulation test voltage	1.64 kV
Colour tolerance	3 SDCM
ESD classification	Severity level 2
Risk group (IEC 62471)	RG1 (> 208 – 600 mA (I _{max})), RGO (≤ 208 mA)
Classification acc. to IEC 62031	Built-in
Type of protection	IP00
Lumen maintenance L70B50	102,000 h
Guarantee (conditions at www.tridonic.com)	5 Year(s)

Approval marks**Standards**

IEC 62031, IEC 62471, IEC 61000-4-2, IEC 62778, IEC 61547

Specific technical data

Type	Article number	Photometric code [®]	Useful luminous flux at $t_p = 25\text{ °C}$ ^④	Expected luminous flux at t_p rated ^⑤	Typ. forward current	Min. forward voltage at t_p rated	Max. forward voltage at $t_p = 25\text{ °C}$	Power consumption P_{on} at $t_p = 25\text{ °C}$ ^⑥	Efficacy of the module at $t_p = 25\text{ °C}$	Expected efficacy of the module at t_p rated	Colour rendering index CRI
Operating mode HE											
LLE 16x280mm 2000lm 830 HV ADV6	28005020	830/359	-	624 lm	100 mA	30.2 V	32.9 V	-	-	197 lm/W	>80
LLE 16x280mm 2000lm 840 HV ADV6	28005021	840/359	-	662 lm	100 mA	30.2 V	32.9 V	-	-	209 lm/W	>80
LLE 16x560mm 4000lm 830 HV ADV6	28005022	830/359	-	1,249 lm	100 mA	60.5 V	65.9 V	-	-	197 lm/W	>80
LLE 16x560mm 4000lm 840 HV ADV6	28005023	840/359	-	1,324 lm	100 mA	60.5 V	65.9 V	-	-	209 lm/W	>80
Operating mode NM											
LLE 16x280mm 2000lm 830 HV ADV6	28005020	830/359	1,909 lm	1,832 lm	300 mA	31.5 V	34.2 V	10.0 W	192 lm/W	186 lm/W	>80
LLE 16x280mm 2000lm 840 HV ADV6	28005021	840/359	2,025 lm	1,944 lm	300 mA	31.5 V	34.2 V	10.0 W	203 lm/W	197 lm/W	>80
LLE 16x560mm 4000lm 830 HV ADV6	28005022	830/359	3,818 lm	3,665 lm	300 mA	63.0 V	68.4 V	19.9 W	192 lm/W	186 lm/W	>80
LLE 16x560mm 4000lm 840 HV ADV6	28005023	840/359	4,050 lm	3,887 lm	300 mA	63.0 V	68.4 V	19.9 W	203 lm/W	197 lm/W	>80
Operating mode HO											
LLE 16x280mm 2000lm 830 HV ADV6	28005020	830/359	-	2,957 lm	500 mA	32.5 V	35.2 V	-	-	175 lm/W	>80
LLE 16x280mm 2000lm 840 HV ADV6	28005021	840/359	-	3,136 lm	500 mA	32.5 V	35.2 V	-	-	185 lm/W	>80
LLE 16x560mm 4000lm 830 HV ADV6	28005022	830/359	-	5,914 lm	500 mA	64.9 V	70.3 V	-	-	175 lm/W	>80
LLE 16x560mm 4000lm 840 HV ADV6	28005023	840/359	-	6,273 lm	500 mA	64.9 V	70.3 V	-	-	185 lm/W	>80

② If mounted with M3 screws with 6 mm head diameter and plastic washer.

③ The detailed explanation, see data sheet section 1.1.

④ Tolerance of useful light flux - 0 % / + 15 %. Measurement uncertainty ± 10 %.

⑤ Measurement uncertainty ± 10 %. Based on calculation.

⑥ Tolerance of power consumption P_{on} ± 10 %. Measurement uncertainty ± 5 %.

ACL LINEAR COVER 16mm

Accessory

**Product description**

- _ LINEAR COVER for LLE 16
- _ Protection against direct touch for non-SELV applications (recommendation: use all fixing points) ^①
- _ Fast snap on mounting on to LLE 16 with clips or plastic washers
- _ High transmission: transparent, semi-transparent and diffuse
- _ Linear lense made of PMMA
- _ Tolerances LINEAR COVER: + 10 mm for 1,600 / 1,200 mm length (ends raw)

① Ends must be covered by the luminaire construction.

Website

<http://www.tridonic.com/28000950>

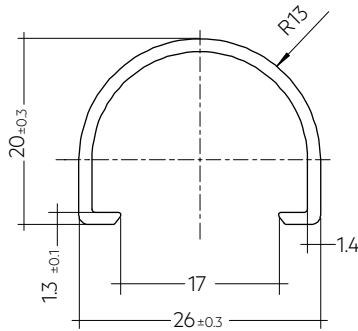
**Ordering data**

Type	Article number	Colour	Length L	Packaging, carton	Weight per pc.
ACL LINEAR COVER 16x1600mm FROSTED	28000950	Semi-transparent	1,600 mm	24 pc(s).	0.147 kg
ACL LINEAR COVER 16x1200mm FROSTED	28002827	Semi-transparent	1,200 mm	24 pc(s).	0.100 kg
ACL LINEAR COVER 16x1600mm DIFFUSE	28000951	Diffuse	1,600 mm	24 pc(s).	0.147 kg
ACL LINEAR COVER 16x1200mm DIFFUSE	28002828	Diffuse	1,200 mm	24 pc(s).	0.100 kg

1. Standards

IEC 62031
IEC 62471
IEC 61000-4-2
IEC 62778
IEC 61547

1.1 Photometric code

Key for photometric code, e. g. 830 / 349

1 st digit	2 nd + 3 rd digit	4 th digit	5 th digit	6 th digit
Code CRI	Colour temperature in Kelvin x 100	MacAdam initial	MacAdam after 25% of the lifetime (max.6000h)	Luminous flux after 25% of the lifetime (max.6000h)
7 70 – 79				Code Luminous flux
8 80 – 89				7 ≥ 70 %
9 ≥90				8 ≥ 80 % 9 ≥ 90 %

1.2 Risk group

Forward current	Risk group (IEC 62471)
≤ 208 mA	RG0
> 208 – 600 mA (Imax)	RG1

1.3 Energy classification

Type	Colour temperature	Forward current	Energy classification	Energy consumption
LLE 16x280mm 2000lm 830 HV ADV6	3,000 K	300 mA	C	10 kWh / 1,000 h
LLE 16x280mm 2000lm 840 HV ADV6	4,000 K	300 mA	B	10 kWh / 1,000 h
LLE 16x560mm 4000lm 830 HV ADV6	3,000 K	300 mA	C	20 kWh / 1,000 h
LLE 16x560mm 4000lm 840 HV ADV6	4,000 K	300 mA	B	20 kWh / 1,000 h

Energy label and further information at www.tridonic.com in the certificates tab of the corresponding product page and at the EPREL data base <https://eprel.ec.europa.eu/>

2. Thermal details

2.1 tc point, ambient temperature and lifetime

The temperature at tp reference point is crucial for the light output and lifetime of a LED product.

For LLE a tp temperature of 65 °C has to be complied in order to achieve an optimum between heat sink requirements, light output and lifetime.

Compliance with the maximum permissible reference temperature at the tc point must be checked under operating conditions in a thermally stable state. The maximum value must be determined under worst-case conditions for the relevant application.

The tc and tp temperature of LED modules from Tridonic are measured at the same reference point.

2.2 Storage and humidity

Storage temperature	-40...+85 °C
---------------------	--------------

Operation only in non condensing environment.

Humidity during processing of the module should be between 30 to 70 %.

2.3 Heat sink values

LLE 16x280mm 2000lm ADV6

ta	tp	Forward current	R _{th, hs-a}	Cooling area
25 °C	65 °C	300 mA	4.64 K/W	144 cm ²
25 °C	65 °C	500 mA	1.84 K/W	363 cm ²
35 °C	65 °C	300 mA	2.35 K/W	283 cm ²
35 °C	65 °C	500 mA	0.67 K/W	990 cm ²
40 °C	65 °C	300 mA	1.21 K/W	550 cm ²
40 °C	65 °C	500 mA	0.09 K/W	7,269 cm ²
45 °C	65 °C	300 mA	0.07 K/W	9,507 cm ²

LLE 16x560mm 4000lm ADV6

ta	tp	Forward current	R _{th, hs-a}	Cooling area
25 °C	65 °C	300 mA	2.32 K/W	288 cm ²
25 °C	65 °C	500 mA	0.92 K/W	726 cm ²
35 °C	65 °C	300 mA	1.18 K/W	567 cm ²
35 °C	65 °C	500 mA	0.34 K/W	1,980 cm ²
40 °C	65 °C	300 mA	0.61 K/W	1,100 cm ²
40 °C	65 °C	500 mA	0.05 K/W	14,539 cm ²
45 °C	65 °C	300 mA	0.04 K/W	19,014 cm ²

Notes

The actual cooling surface can differ because of the material, the structural shape, outside influences and the installation situation. Depending on the heat sink a heat conducting paste or heat conducting film might be necessary to keep the specified tp temperature.

For applications with a small distance between LED module and lens or operating currents higher than 500 mA, screw mounting is recommended to ensure a reliable thermal connection between LED module and cooling surface.

3. Installation / wiring

3.1 Electrical supply/choice of LED driver

LLE modules from Tridonic are not protected against overvoltages, overcurrents, overloads or short-circuit currents. Safe and reliable operation can only be guaranteed in conjunction with a LED driver which complies with the relevant standards. The use of LED driver from Tridonic in combination with LLE modules guarantees the necessary protection for safe and reliable operation.

If a LED driver other than Tridonic is used, it must provide the following protection:

- Short-circuit protection
- Overload protection
- Overtemperature protection



LLE modules must be supplied by a constant current LED driver. Operation with a constant voltage LED driver will lead to an irreversible damage of the module.

Wrong polarity can damage the LLE.

The LLE module is designed for serial wiring.

LLE can be operated either from SELV LED drivers or from LED drivers with LV output voltage.



LLE are basic insulated up to 320 V (if mounted with M3 screws with head diameter 6 mm in combination with plastic washers) against ground and can be mounted directly on earthed metal parts of the luminaire. If the max. output voltage of the LED driver (also against earth) is above 320 V, an additional insulation between LED module and heat sink is required (for example by insulated thermal pads) or by a suitable luminaire construction.

At voltages > 60 V an additional protection against direct touch (test finger) to the light emitting side of the module has to be guaranteed. This is typically achieved by means of a non removable light distributor over the module.

3.2 Wiring



Wiring examples for serial wiring

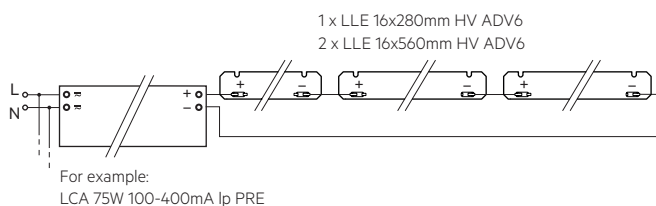
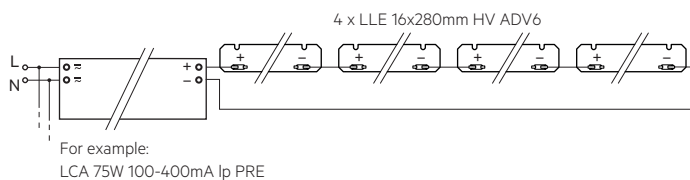

3.3 Wiring type and cross section

For wiring use solid wire from 0.14 to 0.5 mm².

No reconnection with smaller diameters possible if used with >0.34 mm².

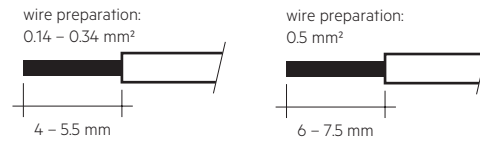

To remove the wires use a suitabel tool (Wago 206-859) or through twist and pull.

3.4 Mounting instruction



None of the components of the LLE (substrate, LED, electronic components etc.) may be exposed to tensile or compressive stresses.

Max. torque for fixing: 0.5 Nm.

The LED modules are mounted onto a heat sink with M3 screws with plastic washers or ACL BRIDGE LLE16 PUSH-FIX.

All fastening point must be used for mounting.

The cut-outs on the end faces must not be used for fastening.

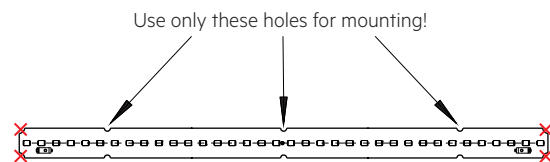

Chemical substance may harm the LED module. Chemical reactions could lead to colour shift, reduced luminous flux or a total failure of the module caused by corrosion of electrical connections.

Materials which are used in LED applications (e.g. sealings, adhesives) must not produce dissolver gas. They must not be condensation curing based, acetate curing based or contain sulfur, chlorine or phthalate.

Avoid corrosive atmosphere during usage and storage.

3.5 EOS/ESD safety guidelines



The device / module contains components that are sensitive to electrostatic discharge and may only be installed in the factory and on site if appropriate EOS/ESD protection measures have been taken. No special measures need be taken for devices/modules with enclosed casings (contact with the pc board not possible), just normal installation practice. Please note the requirements set out in the document EOS / ESD guidelines (Guideline_EOS_ESD.pdf) at: <http://www.tridonic.com/esd-protection>

4. Lifetime

4.1 Lifetime, lumen maintenance and failure rate

The light output of an LED module decreases over the lifetime, this is characterized with the L value.

L70 means that the LED module will give 70 % of its initial luminous flux. This value is always related to the number of operation hours and therefore defines the lifetime of an LED module.

As the L value is a statistical value and the lumen maintenance may vary over the delivered LED modules.

The B value defines the amount of modules which are below the specific L value, e.g. L70B10 means 10 % of the LED modules are below 70 % of the initial luminous flux, respectively 90 % will be above 70 % of the initial value.

In addition the percentage of failed modules (fatal failure) is characterized by the C value.

The F value is the combination of the B and C value. That means for F degradation and complete failures are considered, e.g. L70F10 means 10 % of the LED modules may fail or be below 70 % of the initial luminous flux.

4.2 Lumen maintenance for LLE 16mm HV ADV6

Forward current	tp	L90 / B10	L90 / B50	L80 / B10	L80 / B50	L70 / B10	L70 / B50
	tempera- ture						
600 mA	55 °C	52k h	52k h	> 102k h	> 102k h	> 102k h	> 102k h
	85 °C	52k h	52k h	> 102k h	> 102k h	> 102k h	> 102k h
	95 °C	38k h	38k h	> 102k h	> 102k h	> 102k h	> 102k h

L00C03 >102k h. At tp rated and I rated, based on 10 switching cycles per day.

4.3 Switching capability

100,000 cycles

Tridonic test according to IEC 62717 Cl 10.3.3

30 s on / 30 s off at I_{max}

5. Electrical values

5.1 Declaration of electrical parameters

Irated ... Nominal operating current the module is designed for.

I_{max} ... Max. permissible continuous operating current incl. The tolerances of the LED driver.

Max. permissible LF current ripple ... Max. output current of the LED driver incl. Tolerances and LF current ripple must not exceed this value.

Max. permissible peak current ... The max. output peak current of the LED driver must not exceed this value.

5.2 Typ. forward voltage vs. forward current

LLE 16x280mm 2000lm 8xx HV ADV6

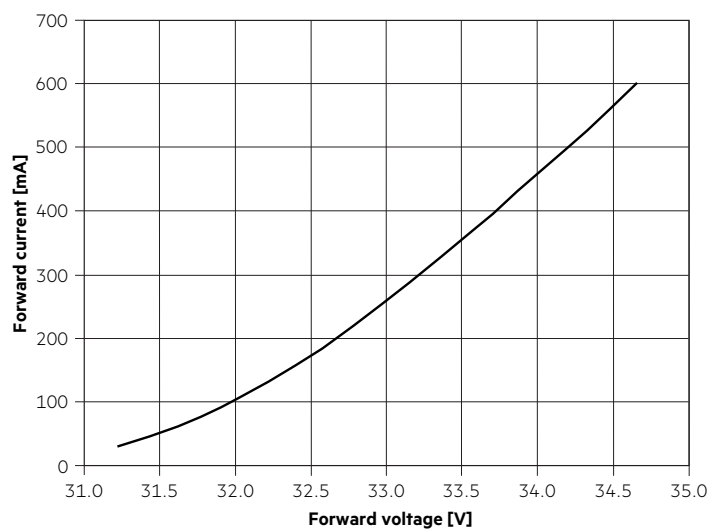

LLE 16x560mm 4000lm 8xx HV ADV6

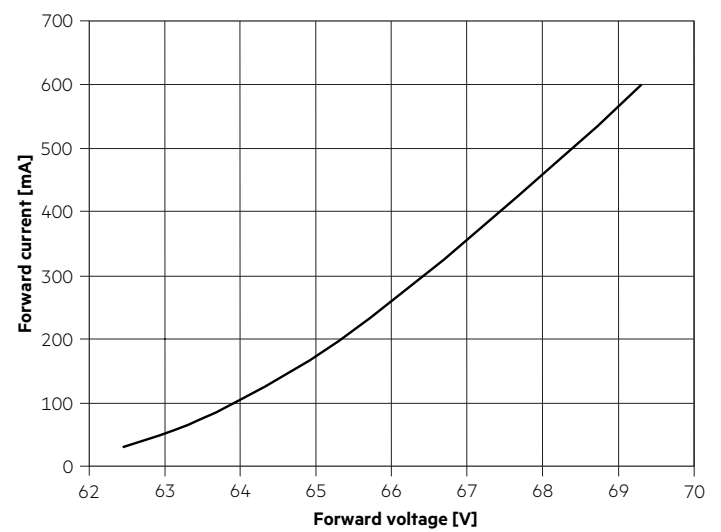

The diagrams are based on statistic values.
The real values can be different.

5.3 Forward voltage vs. tc temperature

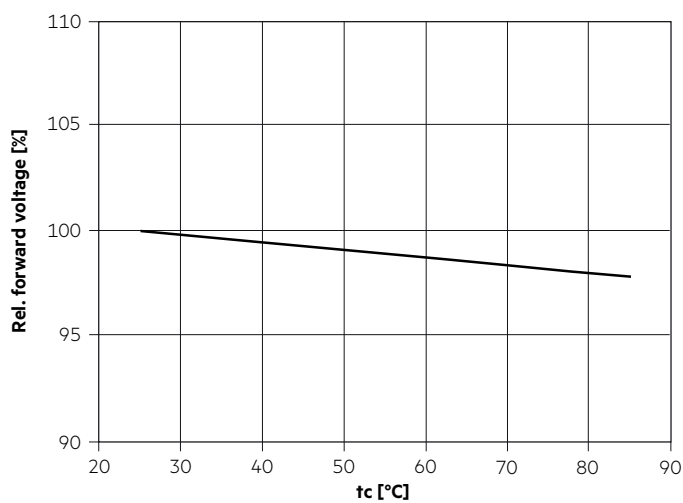

The diagrams are based on statistic values.
The real values can be different.

6. Photometric characteristics

6.1 Coordinates and tolerances according to CIE 1931

The specified colour coordinates are integral measured by current impulse of 195 mA and a duration of 100 ms.

The ambient temperature of the measurement is $t_a = 25^\circ\text{C}$.

The measurement tolerance of the colour coordinates are ± 0.01 .

3,000 K

	x0	y0
Centre	0.4338	0.4030

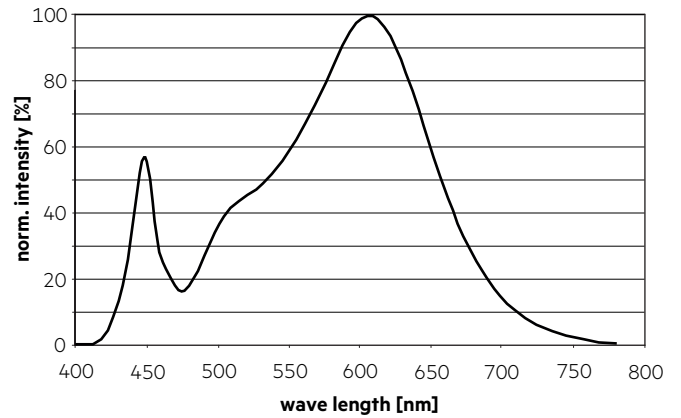
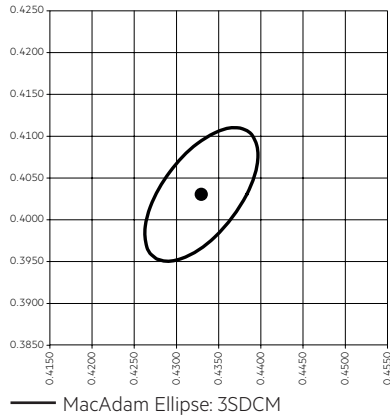

4,000 K

	x0	y0
Center	0.3818	0.3797

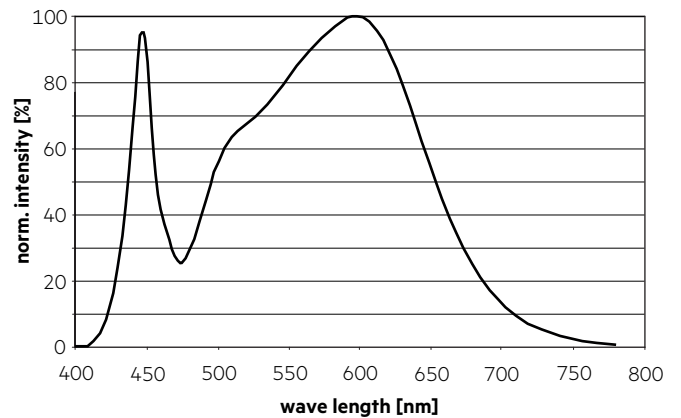
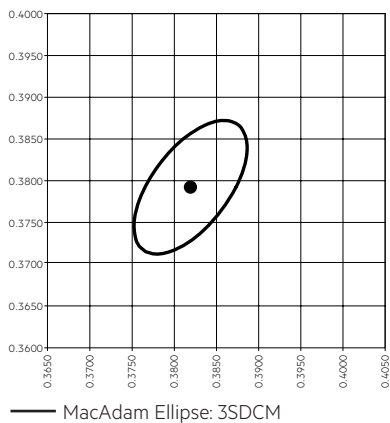

6.2 Light distribution

The optical design of the LLE product line ensures optimum homogeneity for the light distribution.

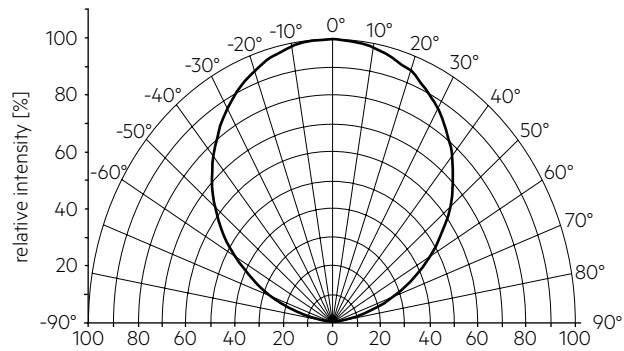

The colour temperature is measured integral over the complete module. The single LED light points can have deviations in the colour coordinates within MacAdam 5. To ensure an ideal mixture of colours and a homogeneous light distribution a suitable optic (e. g. PMMA diffuser) and a sufficient spacing between module and optic (typ. 4 cm) should be used.

6.3 Relative luminous flux vs. tc temperature

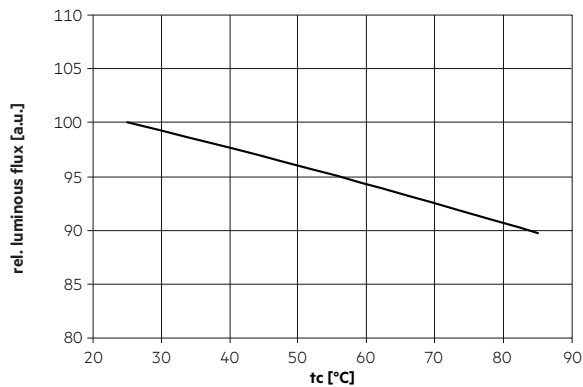

6.4 Relative luminous flux vs. operating current

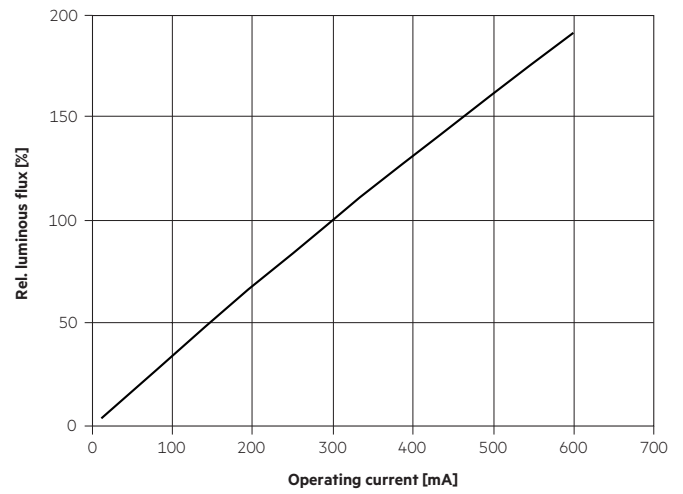

The diagrams are based on statistic values. The real values can be different.

7. Miscellaneous

7.1 Additional information

Additional technical information at www.tridonic.com → Technical Data

Lifetime declarations are informative and represent no warranty claim.