

Module CLE Shallow EXC3

Modules CLE excite

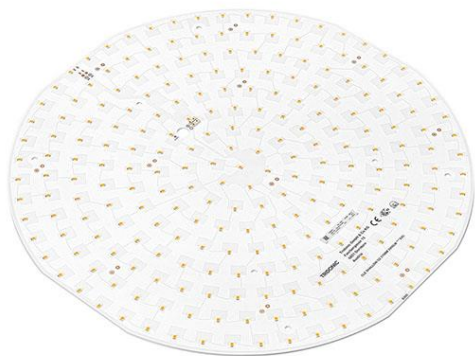

CLE SHALLOW 370mm 2900lm EXC3



CLE SHALLOW 802MM 3800LM EXC3

Product description

- _ Ideal for extra-flat luminaires, minimum backlight distance 30 mm
- _ For round shaped luminaires with a diameter of 370 – 1,082 mm
- _ Compatible with Tridonic ADV, EXC and PRE driver in different modes (HE, NM, HO), enables more flexibility on luminaire design
- _ Self-cooling (no additional heat sink required)
- _ HE ... High Efficiency, NM ... Nominal Mode, HO ... High Output
- _ Long lifetime up to 102,000 hours
- _ 5 years guarantee (Conditions at <https://www.tridonic.com/en/int/services/manufacturer-guarantee-conditions>)

Optical properties

- _ Colour temperatures 3,000, 3,500 and 4,000 K
- _ Efficacy of the LED module up to 190 lm/W
- _ High colour rendering index CRI > 90
- _ Small colour tolerance (MacAdam 3)

Mechanical properties

- _ Module dimension $\varnothing 360$ mm, $\varnothing 522$ mm, $\varnothing 802$ mm and $\varnothing 1,082$ mm, from $\varnothing 522$ mm with several module segments
- _ Simple installation (e.g. screws)

Website

<http://www.tridonic.com/28006354>

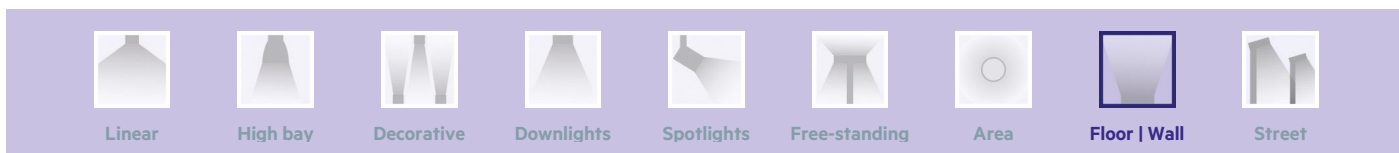

Module CLE Shallow EXC3

Modules CLE excite

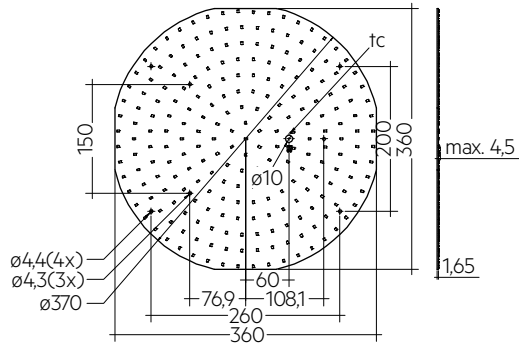

CLE SHALLOW 370mm 2900lm EXC3

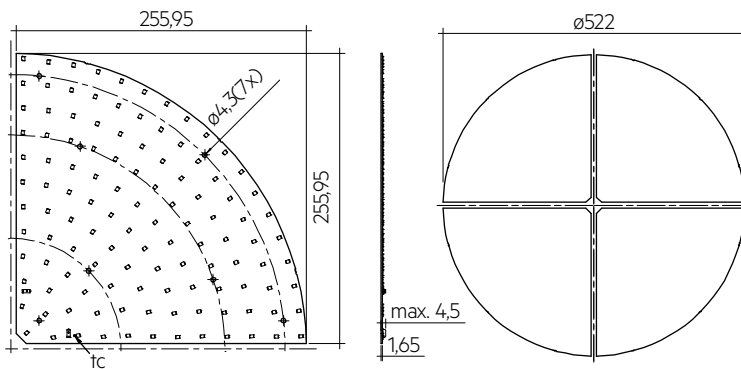

CLE SHALLOW 522MM 1750LM EXC3

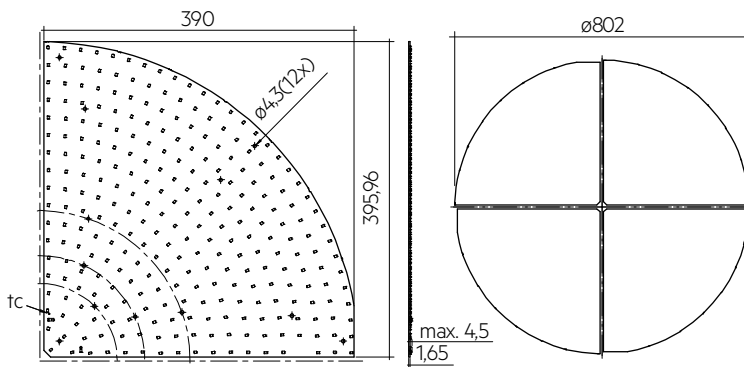

CLE SHALLOW 802MM 3800LM EXC3

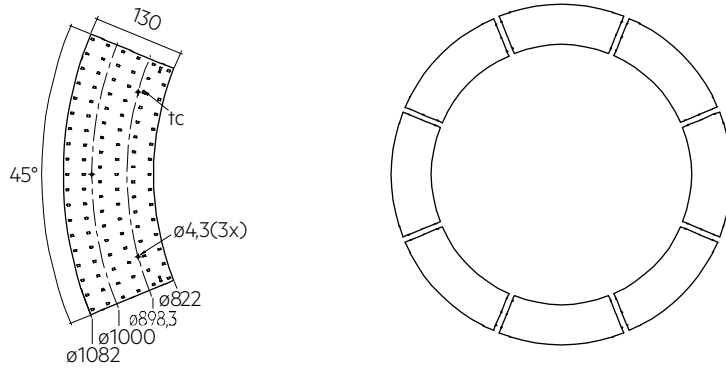

CLE SHALLOW 1082MM 1500LM EXC3

Ordering data

Type	Article number	Colour temperature	Packaging, carton	Weight per pc.
CLE SHALLOW 370MM 2900LM 930 EXC3	28006354	3,000 K	8 pc(s).	0.280 kg
CLE SHALLOW 370MM 2900LM 935 EXC3	28006861	3,500 K	8 pc(s).	0.280 kg
CLE SHALLOW 370MM 2900LM 940 EXC3	28006352	4,000 K	8 pc(s).	0.280 kg
CLE SHALLOW 522MM 1750LM 930 EXC3	28006353	3,000 K	8 pc(s).	0.135 kg
CLE SHALLOW 522MM 1750LM 935 EXC3	28006862	3,500 K	8 pc(s).	0.135 kg
CLE SHALLOW 522MM 1750LM 940 EXC3	28006355	4,000 K	8 pc(s).	0.135 kg
CLE SHALLOW 802MM 3800LM 930 EXC3	28006356	3,000 K	8 pc(s).	0.321 kg
CLE SHALLOW 802MM 3800LM 935 EXC3	28006863	3,500 K	8 pc(s).	0.321 kg
CLE SHALLOW 802MM 3800LM 940 EXC3	28006357	4,000 K	8 pc(s).	0.321 kg
CLE SHALLOW 1082MM 1500LM 930 EXC3	28006358	3,000 K	10 pc(s).	0.124 kg
CLE SHALLOW 1082MM 1500LM 935 EXC3	28006864	3,500 K	10 pc(s).	0.124 kg
CLE SHALLOW 1082MM 1500LM 940 EXC3	28006359	4,000 K	10 pc(s).	0.124 kg

Technical data

Beam characteristic	120°
Ambient temperature ta	-25 ... +65 °C
tp rated	65 °C
tc	85 °C
Irated for CLE Shallow G2 370mm	500 mA
Irated for CLE Shallow G2 522mm	300 mA
Irated for CLE Shallow G2 802mm	700 mA
Irated for CLE Shallow G2 1082mm	450 mA
Imax for CLE Shallow G2 370mm	1,900 mA
Imax for CLE Shallow G2 522mm	950 mA
Imax for CLE Shallow G2 802mm	2,200 mA
Imax for CLE Shallow G2 1082mm	1,350 mA
Max. perm. LF current ripple for CLE S G2 370mm	3,600 mA
Max. perm. LF current ripple for CLE S G2 522mm	1,800 mA
Max. perm. LF current ripple for CLE S G2 802mm	4,200 mA
Max. perm. LF current ripple for CLE S G2 1082mm	2,600 mA
Max. perm. peak current for CLE S G2 370mm	5,400 mA / max. 10 ms
Max. perm. peak current for CLE S G2 522mm	2,700 mA / max. 10 ms
Max. perm. peak current for CLE S G2 802mm	6,300 mA / max. 10 ms
Max. perm. peak current for CLE S G2 1082mm	3,900 mA / max. 10 ms
Max. working voltage for insulation ^①	250 V
Insulation test voltage	1.5 kV
CTI of the printed circuit board	≥ 600
Colour tolerance	3 SDCM
ESD classification	Severity level 2
Risk group (IEC 62471) ^②	RG1
Classification acc. to IEC 62031	Built-in
Type of protection	IP00
Lumen maintenance L70B50	102,000 h
Guarantee (conditions at www.tridonic.com)	5 Year(s)

Approval marks

Standards

IEC 62031, IEC 62471, IEC 62778, IEC 61547, IEC 61000-4-2

Specific technical data

Type	Article number	Photometric code	Useful luminous flux at tp = 25 °C ^①	Expected luminous flux at tp rated ^②	Typ. forward current	Min. forward voltage at tp rated	Max. forward voltage at tp = 25 °C	Power consumption Pon at tp = 25 °C ^③	Efficacy of the module at tp = 25 °C	Expected efficacy of the module at tp rated	Colour rendering index CRI
CLE Shallow 370mm – Operating mode HE at 350 mA											
CLE SHALLOW 370MM 2900LM 930 EXC3	28006354	930/359	-	2,031 lm	350 mA	31.6 V	36.1 V	-	-	174 lm/W	>90
CLE SHALLOW 370MM 2900LM 935 EXC3	28006861	835/359	-	2,085 lm	350 mA	31.6 V	36.1 V	-	-	179 lm/W	>90
CLE SHALLOW 370MM 2900LM 940 EXC3	28006352	940/359	-	2,153 lm	350 mA	31.6 V	36.1 V	-	-	185 lm/W	>90
CLE Shallow 370mm – Operating mode NM at 500 mA											
CLE SHALLOW 370MM 2900LM 930 EXC3	28006354	930/359	3,060 lm	2,927 lm	500 mA	31.9 V	36.4 V	17.1 W	179 lm/W	174 lm/W	>90
CLE SHALLOW 370MM 2900LM 935 EXC3	28006861	835/359	3,130 lm	3,004 lm	500 mA	31.9 V	36.4 V	17.1 W	183 lm/W	179 lm/W	>90
CLE SHALLOW 370MM 2900LM 940 EXC3	28006352	940/359	3,240 lm	3,103 lm	500 mA	31.9 V	36.4 V	17.1 W	189 lm/W	185 lm/W	>90
CLE Shallow 370mm – Operating mode HO at 1400 mA											
CLE SHALLOW 370MM 2900LM 930 EXC3	28006354	930/359	-	8,144 lm	1,400 mA	33.0 V	37.6 V	-	-	167 lm/W	>90
CLE SHALLOW 370MM 2900LM 935 EXC3	28006861	835/359	-	8,359 lm	1,400 mA	33.0 V	37.6 V	-	-	172 lm/W	>90
CLE SHALLOW 370MM 2900LM 940 EXC3	28006352	940/359	-	8,633 lm	1,400 mA	33.0 V	37.6 V	-	-	177 lm/W	>90
CLE Shallow 522mm – Operating mode HE at 180 mA											
CLE SHALLOW 522MM 1750LM 930 EXC3	28006353	930/359	-	1,046 lm	180 mA	31.7 V	36.1 V	-	-	174 lm/W	>90
CLE SHALLOW 522MM 1750LM 935 EXC3	28006862	835/359	-	1,073 lm	180 mA	31.7 V	36.1 V	-	-	179 lm/W	>90
CLE SHALLOW 522MM 1750LM 940 EXC3	28006355	940/359	-	1,108 lm	180 mA	31.7 V	36.1 V	-	-	185 lm/W	>90
CLE Shallow 522mm – Operating mode NM at 300 mA											
CLE SHALLOW 522MM 1750LM 930 EXC3	28006353	930/359	1,840 lm	1,767 lm	300 mA	32.0 V	36.5 V	10.3 W	179 lm/W	175 lm/W	>90
CLE SHALLOW 522MM 1750LM 935 EXC3	28006862	835/359	1,890 lm	1,814 lm	300 mA	32.0 V	36.5 V	10.3 W	183 lm/W	179 lm/W	>90
CLE SHALLOW 522MM 1750LM 940 EXC3	28006355	940/359	1,950 lm	1,873 lm	300 mA	32.0 V	36.5 V	10.3 W	189 lm/W	185 lm/W	>90
CLE Shallow 522mm – Operating mode HO at 700 mA											
CLE SHALLOW 522MM 1750LM 930 EXC3	28006353	930/359	-	4,072 lm	700 mA	33.0 V	37.6 V	-	-	167 lm/W	>90
CLE SHALLOW 522MM 1750LM 935 EXC3	28006862	835/359	-	4,179 lm	700 mA	33.0 V	37.6 V	-	-	172 lm/W	>90
CLE SHALLOW 522MM 1750LM 940 EXC3	28006355	940/359	-	4,317 lm	700 mA	33.0 V	37.6 V	-	-	177 lm/W	>90
CLE Shallow 802mm – Operating mode HE at 400 mA											
CLE SHALLOW 802MM 3800LM 930 EXC3	28006356	930/359	-	2,320 lm	400 mA	31.6 V	34.8 V	-	-	174 lm/W	>90
CLE SHALLOW 802MM 3800LM 935 EXC3	28006863	835/359	-	2,381 lm	400 mA	31.6 V	34.8 V	-	-	179 lm/W	>90
CLE SHALLOW 802MM 3800LM 940 EXC3	28006357	940/359	-	2,459 lm	400 mA	31.6 V	34.8 V	-	-	185 lm/W	>90
CLE Shallow 802mm – Operating mode NM at 700 mA											
CLE SHALLOW 802MM 3800LM 930 EXC3	28006356	930/359	4,310 lm	4,123 lm	700 mA	32.0 V	35.2 V	24.0 W	180 lm/W	175 lm/W	>90
CLE SHALLOW 802MM 3800LM 935 EXC3	28006863	835/359	4,420 lm	4,232 lm	700 mA	32.0 V	35.2 V	24.0 W	184 lm/W	179 lm/W	>90
CLE SHALLOW 802MM 3800LM 940 EXC3	28006357	940/359	4,570 lm	4,371 lm	700 mA	32.0 V	35.2 V	24.0 W	190 lm/W	185 lm/W	>90
CLE Shallow 802mm – Operating mode HO at 1950 mA											
CLE SHALLOW 802MM 3800LM 930 EXC3	28006356	930/359	-	11,252 lm	1,950 mA	33.3 V	36.6 V	-	-	165 lm/W	>90
CLE SHALLOW 802MM 3800LM 935 EXC3	28006863	835/359	-	11,549 lm	1,950 mA	33.3 V	36.6 V	-	-	169 lm/W	>90
CLE SHALLOW 802MM 3800LM 940 EXC3	28006357	940/359	-	11,928 lm	1,950 mA	33.3 V	36.6 V	-	-	175 lm/W	>90
CLE Shallow 1082mm – Operating mode HE at 250 mA											
CLE SHALLOW 1082MM 1500LM 930 EXC3	28006358	930/359	-	892 lm	250 mA	19.5 V	21.4 V	-	-	174 lm/W	>90
CLE SHALLOW 1082MM 1500LM 935 EXC3	28006864	835/359	-	916 lm	250 mA	19.5 V	21.4 V	-	-	179 lm/W	>90
CLE SHALLOW 1082MM 1500LM 940 EXC3	28006359	940/359	-	946 lm	250 mA	19.5 V	21.4 V	-	-	184 lm/W	>90
CLE Shallow 1082mm – Operating mode NM at 450 mA											
CLE SHALLOW 1082MM 1500LM 930 EXC3	28006358	930/359	1,700 lm	1,631 lm	450 mA	19.7 V	21.7 V	9.5 W	179 lm/W	174 lm/W	>90
CLE SHALLOW 1082MM 1500LM 935 EXC3	28006864	835/359	1,740 lm	1,674 lm	450 mA	19.7 V	21.7 V	9.5 W	183 lm/W	179 lm/W	>90
CLE SHALLOW 1082MM 1500LM 940 EXC3	28006359	940/359	1,800 lm	1,729 lm	450 mA	19.7 V	21.7 V	9.5 W	189 lm/W	185 lm/W	>90
CLE Shallow 1082mm – Operating mode HO at 1200 mA											
CLE SHALLOW 1082MM 1500LM 930 EXC3	28006358	930/359	-	4,262 lm	1,200 mA	20.5 V	22.5 V	-	-	165 lm/W	>90
CLE SHALLOW 1082MM 1500LM 935 EXC3	28006864	835/359	-	4,375 lm	1,200 mA	20.5 V	22.5 V	-	-	169 lm/W	>90
CLE SHALLOW 1082MM 1500LM 940 EXC3	28006359	940/359	-	4,518 lm	1,200 mA	20.5 V	22.5 V	-	-	175 lm/W	>90

① If mounted with M4 screws.

② Measured at operating mode HO.

③ Tolerance of useful light flux - 0 % / + 15 %. Measurement uncertainty ± 10 %.

④ Tolerance of expected light flux - 0 % / + 15 %. Measurement uncertainty ± 10 %. Based on calculation.

⑤ Tolerance of power consumption Pon ± 10 %. Measurement uncertainty ± 5 %.

1. Standards

IEC 62031
IEC 62471
IEC 62778
IEC 61547
IEC 61000-4-2

1.1 Photometric code

Key for photometric code, e. g. 830 / 449

1 st digit	2 nd + 3 rd digit	4 th digit	5 th digit	6 th digit	
Code CRI	Colour temperature in Kelvin x 100	MacAdam initial	MacAdam after 25% of the lifetime (max.6000h)	Luminous flux after 25% of the lifetime (max.6000h)	
7 70 – 79				Code	Luminous flux
8 80 – 89				7	≥ 70 %
9 ≥90				8	≥ 80 %
				9	≥ 90 %

1.2 Energy classification

Type	Colour temperature	Forward current	Energy classification	Energy consumption
CLE SHALLOW 370MM 2900LM				
CLE SHALLOW 370MM 2900LM 930 EXC3	3,000 K	500 mA	C	18 kWh / 1,000 h
CLE SHALLOW 370MM 2900LM 935 EXC3	3,500 K	500 mA	C	18 kWh / 1,000 h
CLE SHALLOW 370MM 2900LM 940 EXC3	4,000 K	500 mA	C	18 kWh / 1,000 h
CLE SHALLOW 522MM 1750LM				
CLE SHALLOW 522MM 1750LM 930 EXC3	3,000 K	300 mA	C	11 kWh / 1,000 h
CLE SHALLOW 522MM 1750LM 935 EXC3	3,500 K	300 mA	C	11 kWh / 1,000 h
CLE SHALLOW 522MM 1750LM 940 EXC3	4,000 K	300 mA	C	11 kWh / 1,000 h
CLE SHALLOW 802MM 3800LM				
CLE SHALLOW 802MM 3800LM 930 EXC3	3,000 K	700 mA	C	24 kWh / 1,000 h
CLE SHALLOW 802MM 3800LM 935 EXC3	3,500 K	700 mA	C	24 kWh / 1,000 h
CLE SHALLOW 802MM 3800LM 940 EXC3	4,000 K	700 mA	C	24 kWh / 1,000 h
CLE SHALLOW 1082MM 1500LM				
CLE SHALLOW 1082MM 1500LM 930 EXC3	3,000 K	450 mA	C	10 kWh / 1,000 h
CLE SHALLOW 1082MM 1500LM 935 EXC3	3,500 K	450 mA	C	10 kWh / 1,000 h
CLE SHALLOW 1082MM 1500LM 940 EXC3	4,000 K	450 mA	C	10 kWh / 1,000 h

Energy label and further information at www.tridonic.com in the certificates tab of the corresponding product page and at the EPREL data base <https://eprel.ec.europa.eu/>

2. Thermal details

2.1 tc point, ambient temperature and lifetime

The temperature at tp reference point is crucial for the light output and lifetime of a LED product.

For CLE a tp temperature of 65°C has to be complied in order to achieve an optimum between heat sink requirements, light output and lifetime.

Compliance with the maximum permissible reference temperature at the tc point must be checked under operating conditions in a thermally stable state. The maximum value must be determined under worst-case conditions for the relevant application.

The tc and tp temperature of LED modules from Tridonic are measured at the same reference point.

2.2 Storage and humidity

Storage temperature	-30...+80 °C
---------------------	--------------

Operation only in non condensing environment.
Humidity during processing of the module should be between 30 to 70 %.

2.3 Thermal design and heat sink

The rated life of LED products depends to a large extent on the temperature. If the permissible temperature limits are exceeded, the life of the CLE will be greatly reduced or the CLE may be destroyed.

CLE 370mm 2900lm

ta	tp	Forward current	R _{th, hs-a}	Cooling area
25°C	65°C	350 mA	6.55 K/W	102 cm ²
25°C	65°C	500 mA	4.51 K/W	148 cm ²
25°C	65°C	1,400 mA	1.47 K/W	454 cm ²
35°C	65°C	350 mA	4.90 K/W	136 cm ²
35°C	65°C	500 mA	3.37 K/W	198 cm ²
35°C	65°C	1,400 mA	1.09 K/W	610 cm ²
40°C	65°C	350 mA	4.08 K/W	163 cm ²
40°C	65°C	500 mA	2.81 K/W	238 cm ²
40°C	65°C	1,400 mA	0.90 K/W	737 cm ²
45°C	65°C	350 mA	3.26 K/W	205 cm ²
45°C	65°C	500 mA	2.24 K/W	298 cm ²
45°C	65°C	1,400 mA	0.72 K/W	931 cm ²
50°C	65°C	350 mA	2.43 K/W	274 cm ²
50°C	65°C	500 mA	1.67 K/W	400 cm ²
50°C	65°C	1,400 mA	0.53 K/W	1,263 cm ²
55°C	65°C	350 mA	1.61 K/W	414 cm ²
55°C	65°C	500 mA	1.10 K/W	606 cm ²
55°C	65°C	1,400 mA	0.34 K/W	1,963 cm ²
60°C	65°C	350 mA	0.79 K/W	848 cm ²
60°C	65°C	500 mA	0.53 K/W	1,254 cm ²
60°C	65°C	1,400 mA	0.15 K/W	4,407 cm ²

CLE 522mm 1750lm

ta	tp	Forward current	R _{th, hs-a}	Cooling area
25°C	65°C	180 mA	12.73 K/W	52 cm ²
25°C	65°C	300 mA	7.43 K/W	90 cm ²
25°C	65°C	700 mA	2.95 K/W	226 cm ²
35°C	65°C	180 mA	9.53 K/W	70 cm ²
35°C	65°C	300 mA	5.56 K/W	120 cm ²
35°C	65°C	700 mA	2.19 K/W	304 cm ²
40°C	65°C	180 mA	7.93 K/W	84 cm ²
40°C	65°C	300 mA	4.62 K/W	144 cm ²
40°C	65°C	700 mA	1.82 K/W	367 cm ²
45°C	65°C	180 mA	6.33 K/W	105 cm ²
45°C	65°C	300 mA	3.68 K/W	181 cm ²
45°C	65°C	700 mA	1.44 K/W	463 cm ²
50°C	65°C	180 mA	4.73 K/W	141 cm ²
50°C	65°C	300 mA	2.75 K/W	243 cm ²
50°C	65°C	700 mA	1.06 K/W	627 cm ²
55°C	65°C	180 mA	3.13 K/W	213 cm ²
55°C	65°C	300 mA	1.81 K/W	369 cm ²
55°C	65°C	700 mA	0.69 K/W	970 cm ²
60°C	65°C	180 mA	1.53 K/W	435 cm ²
60°C	65°C	300 mA	0.87 K/W	765 cm ²
60°C	65°C	700 mA	0.31 K/W	2,145 cm ²

CLE 802mm 3800lm

ta	tp	Forward current	R _{th, hs-a}	Cooling area
25°C	65°C	400 mA	6.29 K/W	106 cm ²
25°C	65°C	700 mA	3.48 K/W	192 cm ²
25°C	65°C	1,950 mA	1.12 K/W	594 cm ²
35°C	65°C	400 mA	4.71 K/W	142 cm ²
35°C	65°C	700 mA	2.60 K/W	256 cm ²
35°C	65°C	1,950 mA	0.83 K/W	800 cm ²
40°C	65°C	400 mA	3.92 K/W	170 cm ²
40°C	65°C	700 mA	2.16 K/W	308 cm ²
40°C	65°C	1,950 mA	0.69 K/W	966 cm ²
45°C	65°C	400 mA	3.13 K/W	213 cm ²
45°C	65°C	700 mA	1.72 K/W	387 cm ²
45°C	65°C	1,950 mA	0.55 K/W	1,221 cm ²
50°C	65°C	400 mA	2.34 K/W	285 cm ²
50°C	65°C	700 mA	1.29 K/W	518 cm ²
50°C	65°C	1,950 mA	0.40 K/W	1,659 cm ²
55°C	65°C	400 mA	1.55 K/W	430 cm ²
55°C	65°C	700 mA	0.85 K/W	787 cm ²
55°C	65°C	1,950 mA	0.26 K/W	2,586 cm ²
60°C	65°C	400 mA	0.76 K/W	878 cm ²
60°C	65°C	700 mA	0.41 K/W	1,632 cm ²
60°C	65°C	1,950 mA	0.11 K/W	5,860 cm ²

CLE 1082mm 1500lm

ta	tp	Forward current	R _{th, hs-a}	Cooling area
25°C	65°C	250 mA	16.15 K/W	41 cm ²
25°C	65°C	450 mA	8.66 K/W	77 cm ²
25°C	65°C	1,200 mA	2.92 K/W	228 cm ²
35°C	65°C	250 mA	12.09 K/W	55 cm ²
35°C	65°C	450 mA	6.47 K/W	103 cm ²
35°C	65°C	1,200 mA	2.17 K/W	307 cm ²
40°C	65°C	250 mA	10.06 K/W	66 cm ²
40°C	65°C	450 mA	5.38 K/W	124 cm ²
40°C	65°C	1,200 mA	1.79 K/W	372 cm ²
45°C	65°C	250 mA	8.03 K/W	83 cm ²
45°C	65°C	450 mA	4.29 K/W	156 cm ²
45°C	65°C	1,200 mA	1.42 K/W	471 cm ²
50°C	65°C	250 mA	6.00 K/W	111 cm ²
50°C	65°C	450 mA	3.19 K/W	209 cm ²
50°C	65°C	1,200 mA	1.04 K/W	642 cm ²
55°C	65°C	250 mA	3.97 K/W	168 cm ²
55°C	65°C	450 mA	2.10 K/W	318 cm ²
55°C	65°C	1,200 mA	0.66 K/W	1,007 cm ²
60°C	65°C	250 mA	1.94 K/W	344 cm ²
60°C	65°C	450 mA	1.00 K/W	665 cm ²
60°C	65°C	1,200 mA	0.29 K/W	2,335 cm ²

Notes

The actual cooling can differ because of the material, the structural shape, outside influences and the installation situation. A thermal connection between CLE and heat sink with heat-conducting paste or heat conducting adhesive film is absolutely necessary.

Additionally the CLE has to be fixed on the heat sink with M3 screws to optimise the thermal connection.

Use of thermal interface material with thermal conductivity of $\lambda > 1$ W/mK and layer thickness of interface material with max. 50 μ m or a similar interface material where the quotient of layer thickness and thermal conductivity $b < 50$ μ mK/W.

3. Installation / wiring**3.1 Electrical supply/choice of LED driver**

CLE from Tridonic are not protected against overvoltages, overcurrents, overloads or short-circuit currents. Safe and reliable operation can only be guaranteed in conjunction with a LED driver which complies with the relevant standards. The use of LED driver from Tridonic in combination with CLE guarantees the necessary protection for safe and reliable operation.

If a LED driver other than Tridonic is used, it must provide the following protection:

- Short-circuit protection
- Overload protection
- Overtemperature protection



CLE must be supplied by a constant current LED driver.

Operation with a constant voltage LED driver will lead to an irreversible damage of the module.

Wrong polarity can damage the CLE.

With serial wiring tolerance-related differences in output are possible (thermal stress of the module) and can cause differences in brightness. If one module fails, the remaining modules may be overloaded.

CLE can be operated either from SELV LED drivers or from LED drivers with LV output voltage.



CLE are basic insulated up to 250 V against ground and can be mounted directly on earthed metal parts of the luminaire. If the max. output voltage of the led Driver (also against earth) is above 250 V, an additional insulation between LED module and heat sink is required (for example by insulated thermal pads) or by a suitable luminaire construction.

At voltages > 60 V an additional protection against direct touch (test finger) to the light emitting side of the module has to be guaranteed. This is typically achieved by means of a non removable light distributor over the module.

3.2 Wiring

CLE SHALLOW 370MM 2900LM EXC3

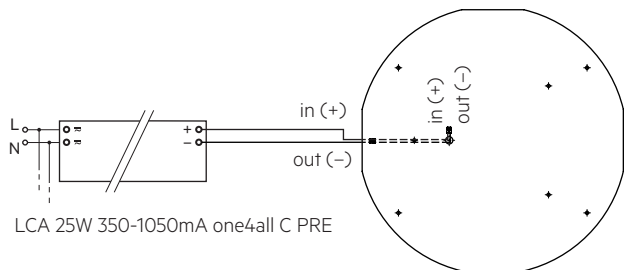

LCA 25W 350-1050mA one4all C PRE

CLE Shallow G2 522/802mm 1750/3800lm EXC3

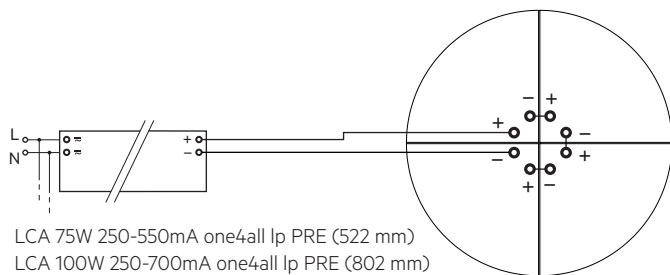

LCA 75W 250-550mA one4all lp PRE (522 mm)
LCA 100W 250-700mA one4all lp PRE (802 mm)

CLE SHALLOW 1082MM 1500lm EXC3

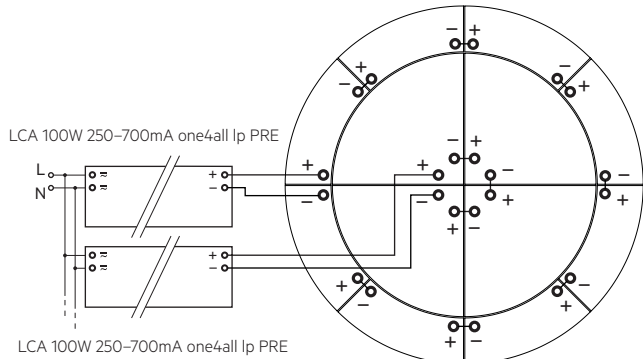

LCA 100W 250-700mA one4all lp PRE

LCA 100W 250-700mA one4all lp PRE

3.3 Wiring type and cross section

For wiring use solid wire from 0.14 to 0.5 mm².
No reconnection with smaller diameters possible if used with >0.34 mm².

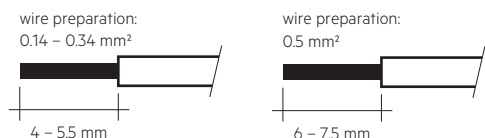

To remove the wires use a suitabel tool (Wago 206-859) or through twist and pull.

3.4 Mounting instruction

! None of the components of the CLE (substrate, LED, electronic components etc.) may be exposed to tensile or compressive stresses.

Max. torque for fixing: 0.5 Nm.

The LED modules are mounted with M4 screws or with ACL clips. In order not to damage the modules only rounded head screws and an additional plastic flat washer should be used.

! Chemical substance may harm the LED module. Chemical reactions could lead to colour shift, reduced luminous flux or a total failure of the module caused by corrosion of electrical connections.

Materials which are used in LED applications (e.g. sealings, adhesives) must not produce dissolver gas. They must not be condensation curing based, acetate curing based or contain sulfur, chlorine or phthalate.
Avoid corrosive atmosphere during usage and storage.

CLE SHALLOW 522MM 1750lm EXC3

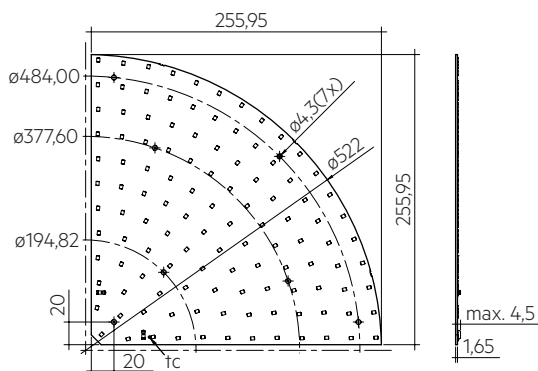

CLE SHALLOW 802MM 3800lm EXC3

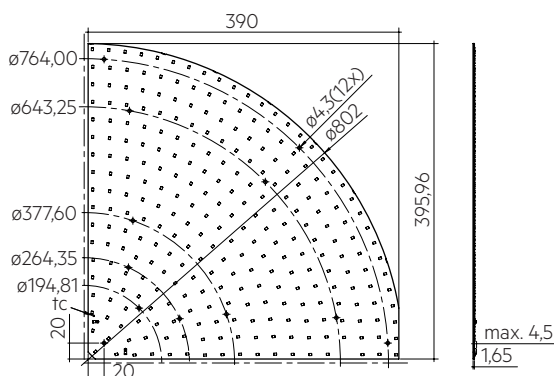

CLE SHALLOW 1082MM 1500lm EXC3

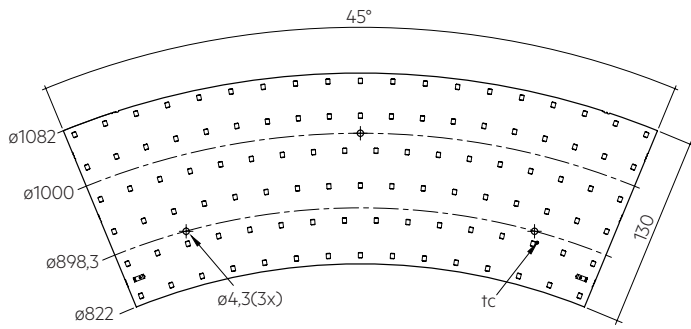

3.5 EOS/ESD safety guidelines



The device / module contains components that are sensitive to electrostatic discharge and may only be installed in the factory and on site if appropriate EOS/ESD protection measures have been taken. No special measures need be taken for devices/modules with enclosed casings (contact with the pc board not possible), just normal installation practice. Please note the requirements set out in the document EOS / ESD guidelines (Guideline_EOS_ESD.pdf) at: <http://www.tridonic.com/esd-protection>

4. Lifetime

4.1 Lifetime, lumen maintenance and failure rate

The light output of an LED module decreases over the lifetime, this is characterized with the L value. L70 means that the LED module will give 70 % of its initial luminous flux. This value is always related to the number of operation hours and therefore defines the lifetime of an LED module.

As the L value is a statistical value and the lumen maintenance may vary over the delivered LED modules.

The B value defines the amount of modules which are below the specific L value, e.g. L70B10 means 10 % of the LED modules are below 70 % of the initial luminous flux, respectively 90 % will be above 70 % of the initial value. In addition the percentage of failed modules (fatal failure) is characterized by the C value.

The F value is the combination of the B and C value. That means for F degradation and complete failures are considered, e.g. L70F10 means 10 % of the LED modules may fail or be below 70 % of the initial luminous flux.

4.2 Lumen maintenance for CLE

CLE SHALLOW 370MM 2900LM EXC3

Forward current	tp temperature	L90 / B10	L90 / B50	L80 / B10	L80 / B50	L70 / B10	L70 / B50
1400 mA	55 °C	> 102,000 h	> 102,000 h	> 102,000 h	> 102,000 h	> 102,000 h	> 102,000 h
	60 °C	> 102,000 h	> 102,000 h	> 102,000 h	> 102,000 h	> 102,000 h	> 102,000 h
	65 °C	> 102,000 h	> 102,000 h	> 102,000 h	> 102,000 h	> 102,000 h	> 102,000 h
	70 °C	> 102,000 h	> 102,000 h	> 102,000 h	> 102,000 h	> 102,000 h	> 102,000 h
	75 °C	> 102,000 h	> 102,000 h	> 102,000 h	> 102,000 h	> 102,000 h	> 102,000 h

CLE Shallow G2 522mm 1750lm EXC3

Forward current	tp temperature	L90 / B10	L90 / B50	L80 / B10	L80 / B50	L70 / B10	L70 / B50
700 mA	55 °C	> 102,000 h	> 102,000 h	> 102,000 h	> 102,000 h	> 102,000 h	> 102,000 h
	60 °C	> 102,000 h	> 102,000 h	> 102,000 h	> 102,000 h	> 102,000 h	> 102,000 h
	65 °C	> 102,000 h	> 102,000 h	> 102,000 h	> 102,000 h	> 102,000 h	> 102,000 h
	70 °C	> 102,000 h	> 102,000 h	> 102,000 h	> 102,000 h	> 102,000 h	> 102,000 h
	75 °C	> 102,000 h	> 102,000 h	> 102,000 h	> 102,000 h	> 102,000 h	> 102,000 h

CLE Shallow G2 802mm 3800lm EXC3

Forward current	tp temperature	L90 / B10	L90 / B50	L80 / B10	L80 / B50	L70 / B10	L70 / B50
1950 mA	55 °C	> 102,000 h	> 102,000 h	> 102,000 h	> 102,000 h	> 102,000 h	> 102,000 h
	60 °C	> 102,000 h	> 102,000 h	> 102,000 h	> 102,000 h	> 102,000 h	> 102,000 h
	65 °C	> 102,000 h	> 102,000 h	> 102,000 h	> 102,000 h	> 102,000 h	> 102,000 h
	70 °C	> 102,000 h	> 102,000 h	> 102,000 h	> 102,000 h	> 102,000 h	> 102,000 h
	75 °C	> 102,000 h	> 102,000 h	> 102,000 h	> 102,000 h	> 102,000 h	> 102,000 h

CLE Shallow G2 1082mm 1500lm EXC3

Forward current	tp temperature	L90 / B10	L90 / B50	L80 / B10	L80 / B50	L70 / B10	L70 / B50
1200 mA	55 °C	> 102,000 h	> 102,000 h	> 102,000 h	> 102,000 h	> 102,000 h	> 102,000 h
	60 °C	> 102,000 h	> 102,000 h	> 102,000 h	> 102,000 h	> 102,000 h	> 102,000 h
	65 °C	> 102,000 h	> 102,000 h	> 102,000 h	> 102,000 h	> 102,000 h	> 102,000 h
	70 °C	> 102,000 h	> 102,000 h	> 102,000 h	> 102,000 h	> 102,000 h	> 102,000 h
	75 °C	> 102,000 h	> 102,000 h	> 102,000 h	> 102,000 h	> 102,000 h	> 102,000 h

5. Electrical values

5.1 Typ. forward voltage vs. forward current

CLE SHALLOW 370MM 2900LM

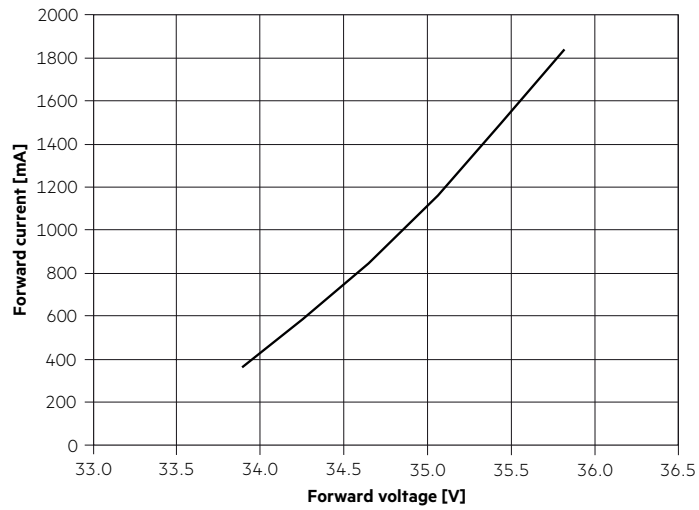

CLE SHALLOW 1082MM 1500lm

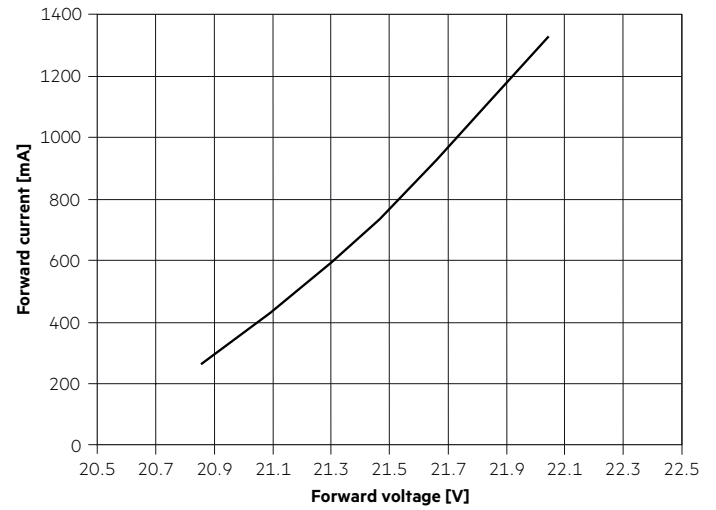

CLE SHALLOW 522MM 1750lm

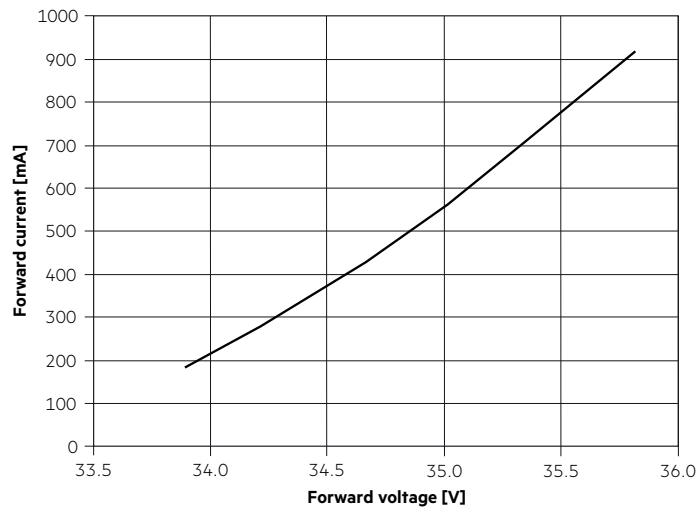

5.2 Forward voltage vs. t_c temperature

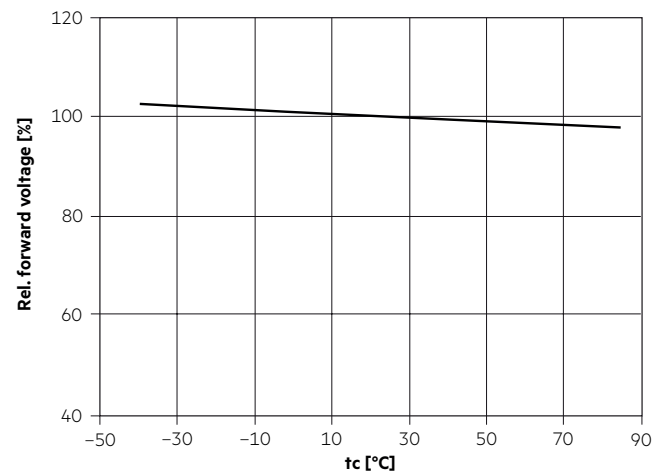

CLE SHALLOW 802MM 3800lm

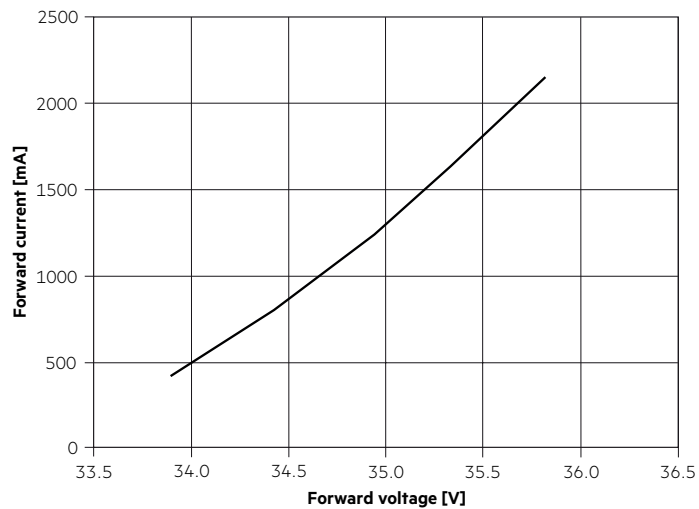

The diagrams are based on statistic values.
The real values can be different.

6. Photometric characteristics

6.1 Coordinates and tolerances according to CIE 1931

MacAdams 3 is for: CLE 370 mm and 522 mm

MacAdams 2 is for: CLE 802 mm and 1082 mm

The specified colour coordinates are measured integral after a settling time of 100 ms. The current impuls depends on the module type.

The ambient temperature of the measurement is $t_a = 25^\circ\text{C}$.

The measurement tolerance of the colour coordinates are ± 0.01 .

Module type	Current impulse
CLE SHALLOW 370MM 2900LM 9x0 EXC3	990 mA
CLE SHALLOW 522MM 1750LM 9x0 EXC3	495 mA
CLE SHALLOW 802MM 3800LM 9x0 EXC3	1,155 mA
CLE SHALLOW 1082MM 1500LM 9x0 EXC3	715 mA

3,000 K

	x0	y0
Centre	0.4338	0.4030

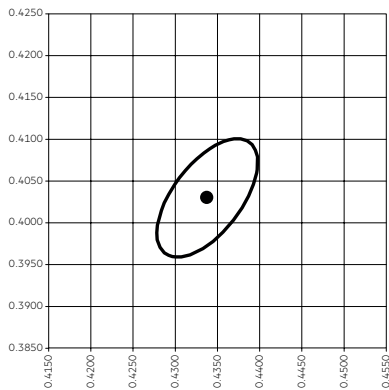

— MacAdam Ellipse: 3SDCM

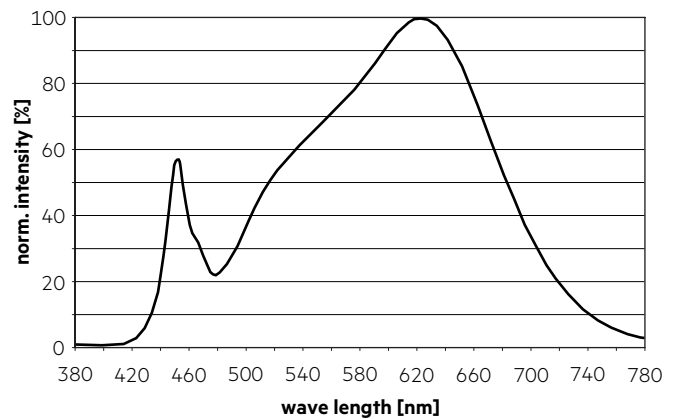

3,500 K

	x0	y0
Centre	0.4073	0.3917

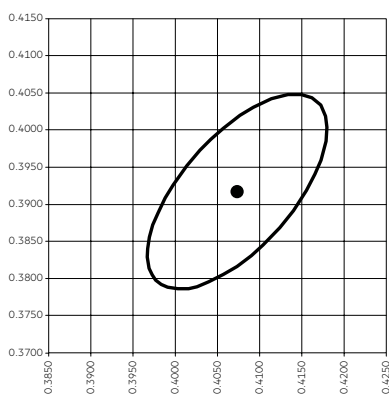

— MacAdam Ellipse: 3SDCM

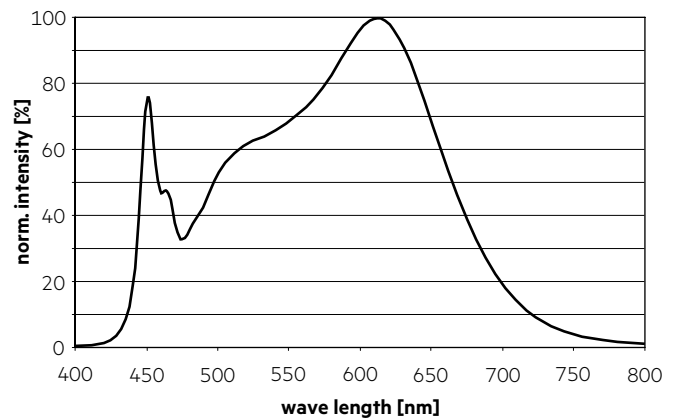

4,000 K

	x0	y0
Centre	0.3818	0.3797

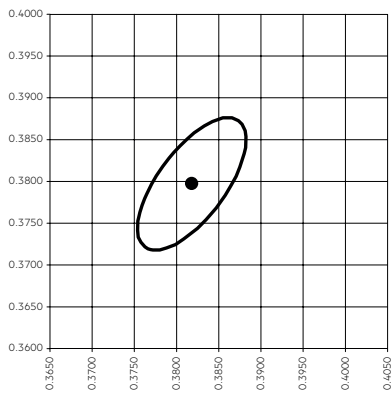

— MacAdam Ellipse: 3SDCM

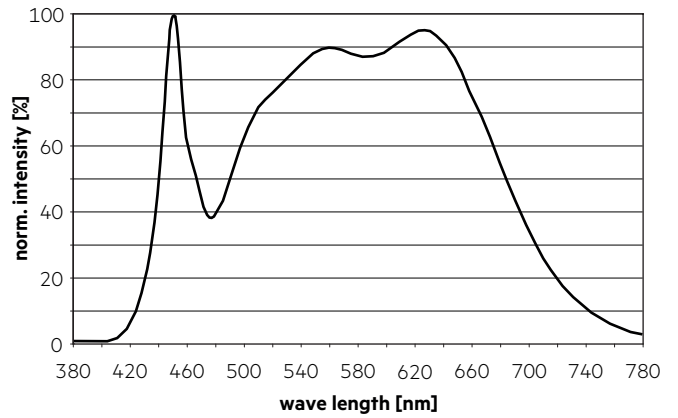

3,000 K

	x0	y0
Centre	0.4338	0.4030

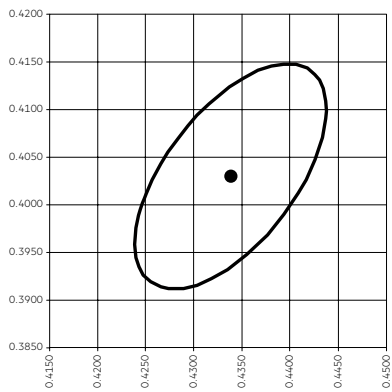

— MacAdam Ellipse: 2SDCM

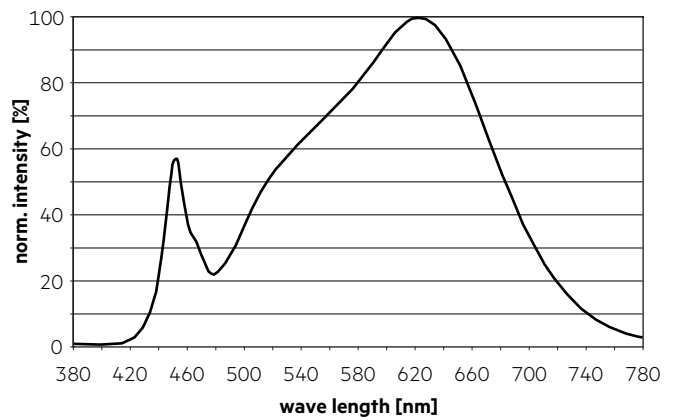

3,500 K

	x0	y0
Centre	0.4073	0.3917

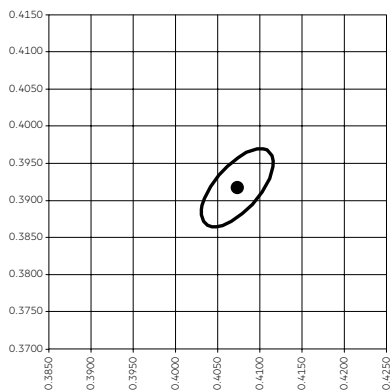

— MacAdam Ellipse: 2SDCM

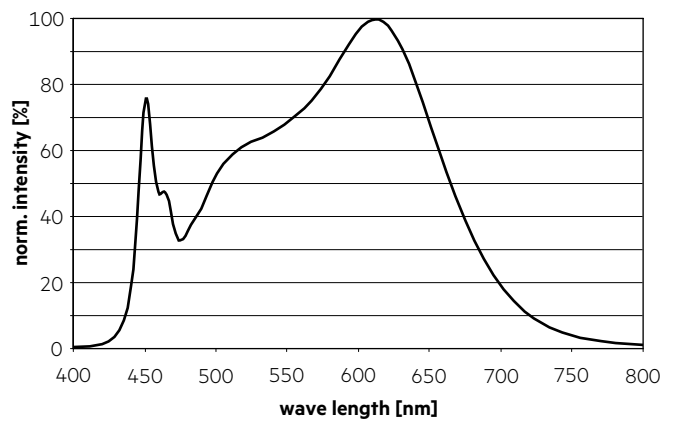

4,000 K

	x0	y0
Centre	0.3818	0.3797

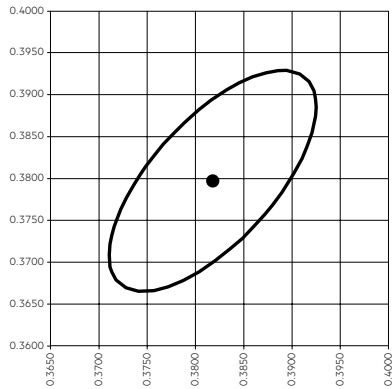

— MacAdam Ellipse: 2SDCM

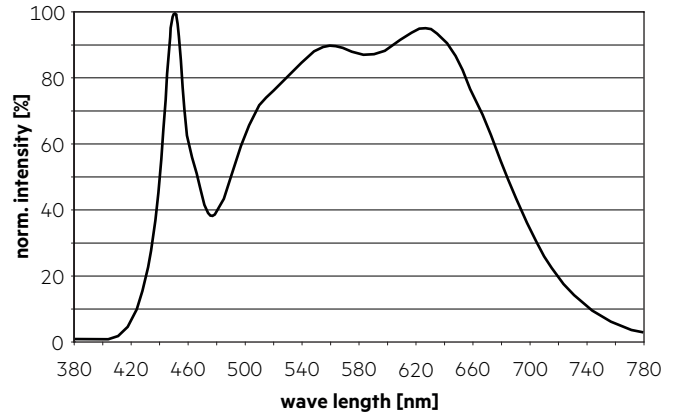

6.2 Light distribution

The optical design of the CLE product line ensures optimum homogeneity for the light distribution.

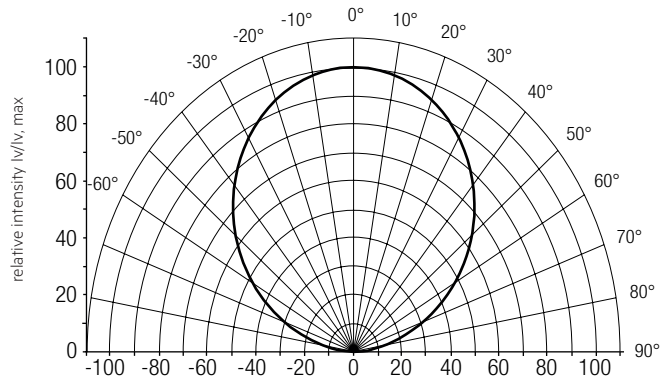

The colour temperature is measured over the complete module. The single LED light points can be outside of 3SDCM. To ensure an ideal mixture of colours and a homogeneous light distribution a suitable optic (e. g. PMMA diffuser) and a sufficient spacing between module and optic (typ. 7 cm) should be used.

6.3 Relative luminous flux vs. tc temperature

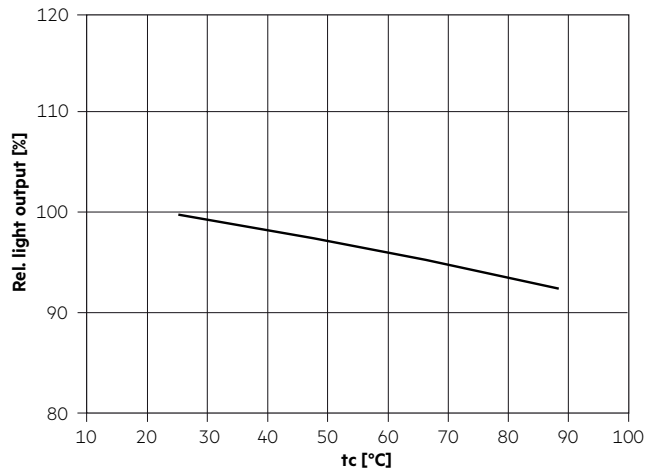

CLE SHALLOW 802MM 3800lm

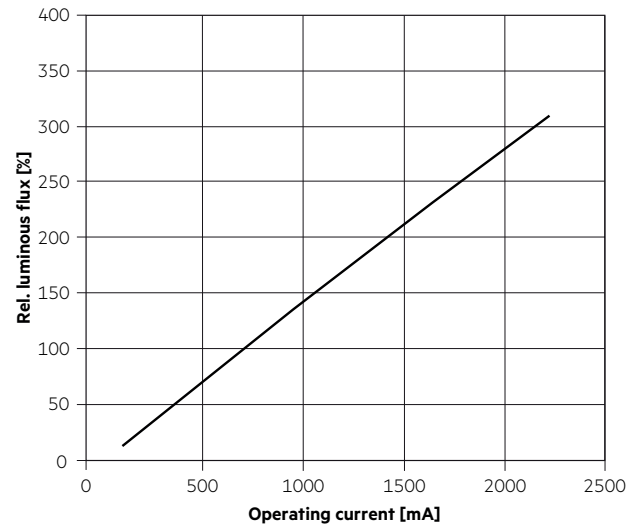

6.4 Relative luminous flux vs. operating current

CLE SHALLOW 370MM 2900LM

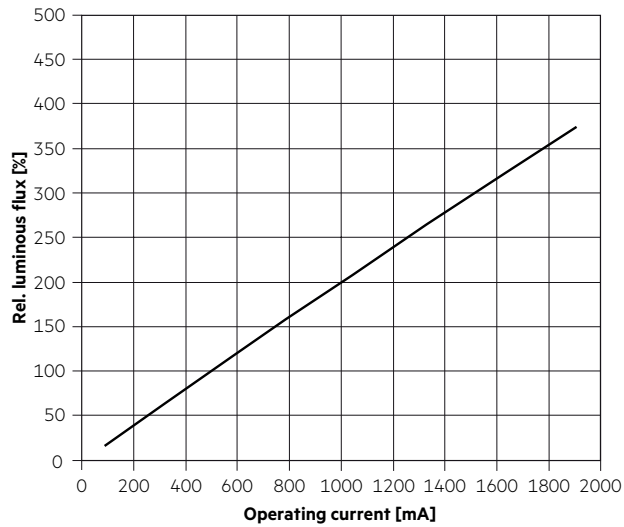

CLE SHALLOW 1082MM 1500lm

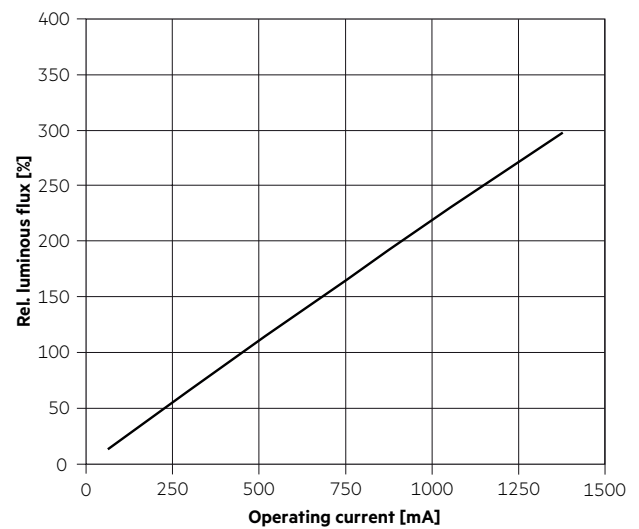

CLE SHALLOW 522MM 1750lm

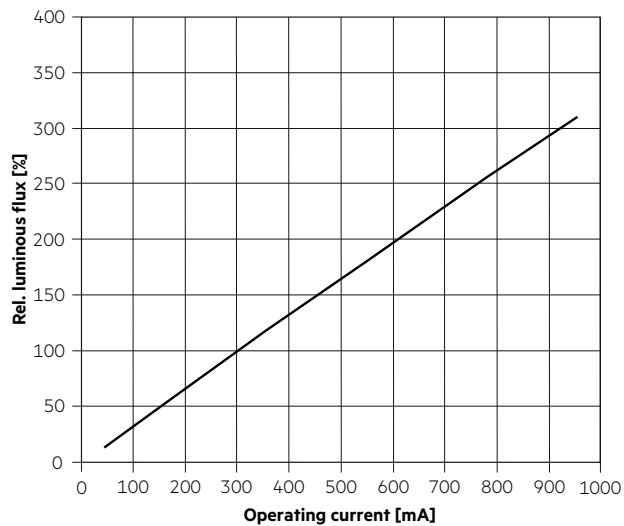

7. Miscellaneous

7.1 Additional information

Additional technical information at www.tridonic.com → Technical Data

Guarantee conditions at www.tridonic.com → Services

Lifetime declarations are informative and represent no warranty claim.