

Module CLE G1 SNC

Modules CLE essence



CLE G1 50mm 1000lm SNC



CLE G1 80mm 2000lm SNC



CLE G1 120mm 2500lm SNC

Product description

- _ Ideal for downlight and decorative ceiling and wall light
- _ Push terminals for quick and simple wiring
- _ Long lifetime: 50,000 hours
- _ 5 years guarantee (conditions at <https://www.tridonic.com/manufacturer-guarantee-conditions>)

Optical properties

- _ Colour temperatures 3,000 and 4,000 K
- _ Useful luminous flux 4,231 lm at Irated and tp = 25 °C
- _ Efficacy of the LED module 134 lm/W at Irated and tp = 25 °C
- _ High colour rendering index CRI > 80
- _ Small colour tolerance (MacAdam 4) ^①
- _ Small luminous flux tolerances

Mechanical properties

- _ Module dimension ø50 mm, ø80 mm, ø120 mm, ø160 mm and ø315 mm
- _ Simple installation (e.g. screws)

^① Integral measurement over the complete module.

Website

<http://www.tridonic.com/89602904>

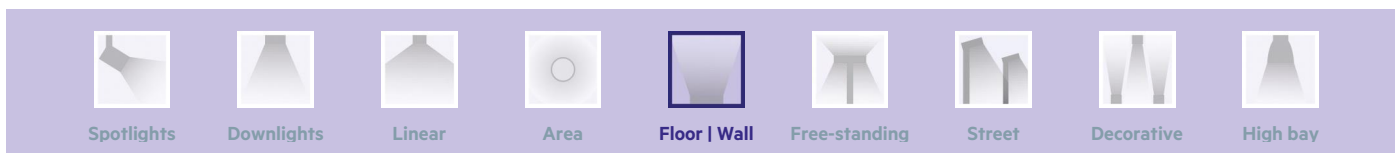

Module CLE G1 SNC
Modules CLE essence

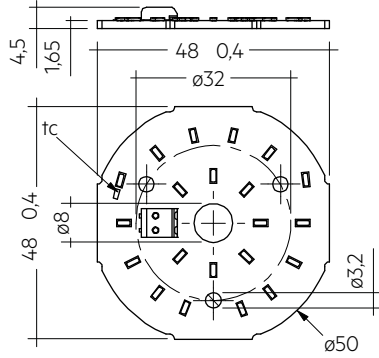

CLE G1 50mm 1000lm SNC

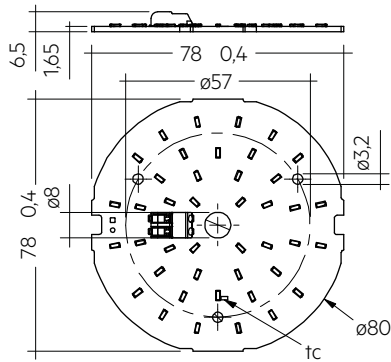

CLE G1 80mm 2000lm SNC

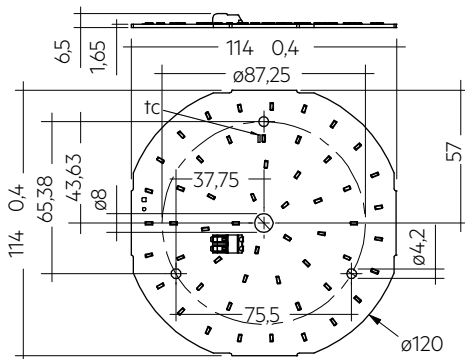

CLE G1 120mm 2500lm SNC

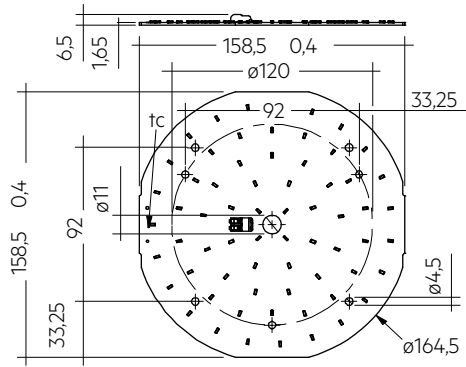

CLE G1 160mm 3000lm SNC

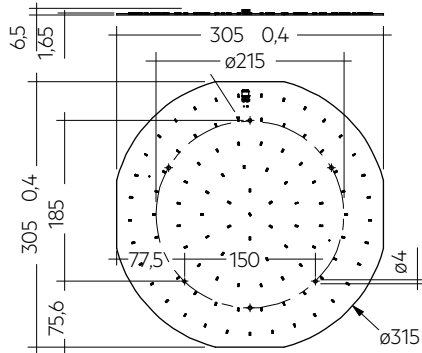

CLE G1 315mm 4000lm SNC

Ordering data

Type	Article number	Colour temperature	Packaging, carton	Weight per pc.
CLE G1 50mm 1000lm 830 SNC	89602904	3,000 K	180 pc(s).	0.008 kg
CLE G1 50mm 1000lm 840 SNC	89602905	4,000 K	180 pc(s).	0.008 kg
CLE G1 80mm 2000lm 830 SNC	89602906	3,000 K	360 pc(s).	0.014 kg
CLE G1 80mm 2000lm 840 SNC	89602907	4,000 K	360 pc(s).	0.014 kg
CLE G1 120mm 2500lm 830 SNC	89602908	3,000 K	360 pc(s).	0.031 kg
CLE G1 120mm 2500lm 840 SNC	89602909	4,000 K	360 pc(s).	0.031 kg
CLE G1 160mm 3000lm 830 SNC	89602910	3,000 K	50 pc(s).	0.059 kg
CLE G1 160mm 3000lm 840 SNC	89602911	4,000 K	50 pc(s).	0.059 kg
CLE G1 315mm 4000lm 830 SNC	89602912	3,000 K	10 pc(s).	0.208 kg
CLE G1 315mm 4000lm 840 SNC	89602913	4,000 K	10 pc(s).	0.208 kg

Technical data

Beam characteristic	120°
Ambient temperature t_a	-25 ... +45 °C
t_p rated	65 °C
t_c	85 °C
I _{rated} for CLE 50mm	350 mA
I _{rated} for CLE 80mm	700 mA
I _{rated} for CLE 120mm	600 mA
I _{rated} for CLE 160mm	700 mA
I _{rated} for CLE 315mm	900 mA
I _{max} for CLE 50mm	376 mA
I _{max} for CLE 80mm	752 mA
I _{max} for CLE 120mm	645 mA
I _{max} for CLE 160mm	752 mA
I _{max} for CLE 315mm	967 mA
Max. permissible LF current ripple for CLE 50mm	526 mA
Max. permissible LF current ripple for CLE 80mm	990 mA
Max. permissible LF current ripple for CLE 120mm	839 mA
Max. permissible LF current ripple for CLE 160mm	990 mA
Max. permissible LF current ripple for CLE 315mm	1,485 mA
Max. permissible peak current for CLE 50mm	600 mA / max. 10 ms
Max. permissible peak current for CLE 80mm	1,200 mA / max. 10 ms
Max. permissible peak current for CLE 120mm	1,000 mA / max. 10 ms
Max. permissible peak current for CLE 160mm	1,200 mA / max. 10 ms
Max. permissible peak current for CLE 315mm	1,800 mA / max. 10 ms
Max. working voltage for insulation SELV ²⁾	< 60 V
Insulation test voltage	0.5 kV
Colour tolerance	4 SDCM
ESD classification	Severity level 4
Risk group (IEC 62471)	RG0
Type of protection	IP00
Lumen maintenance L70B50	50,000 h
Guarantee (conditions at www.tridonic.com)	5 Year(s)

Approval marks**Standards**

IEC 62031, IEC 62471, IEC 62778, IEC 61547

Specific technical data

Type	Article number	Photometric code	Useful luminous flux at $t_p = 25^\circ\text{C}$ ³⁾	Expected luminous flux at t_p rated ⁴⁾	Typ. forward current	Min. forward voltage at t_p rated	Max. forward voltage at $t_p = 25^\circ\text{C}$	Power consumption P_{on} at $t_p = 25^\circ\text{C}$ ⁵⁾	Efficacy of the module at $t_p = 25^\circ\text{C}$	Expected efficacy of the module at t_p rated	Colour rendering index CRI
CLE G1 50mm 1000lm 830 SNC	89602904	830/459	983 lm	917 lm	350 mA	21.2 V	24.5 V	7.9 W	124 lm/W	119 lm/W	>80
CLE G1 50mm 1000lm 840 SNC	89602905	840/459	1,026 lm	952 lm	350 mA	21.2 V	24.5 V	7.9 W	130 lm/W	124 lm/W	>80
CLE G1 80mm 2000lm 830 SNC	89602906	830/459	1,970 lm	1,837 lm	700 mA	21.2 V	24.5 V	15.9 W	124 lm/W	118 lm/W	>80
CLE G1 80mm 2000lm 840 SNC	89602907	840/459	2,061 lm	1,922 lm	700 mA	21.2 V	24.5 V	15.9 W	130 lm/W	124 lm/W	>80
CLE G1 120mm 2500lm 830 SNC	89602908	830/459	2,621 lm	2,443 lm	600 mA	33.4 V	38.6 V	21.4 W	122 lm/W	117 lm/W	>80
CLE G1 120mm 2500lm 840 SNC	89602909	840/459	2,750 lm	2,574 lm	600 mA	33.4 V	38.6 V	21.4 W	129 lm/W	123 lm/W	>80
CLE G1 160mm 3000lm 830 SNC	89602910	830/459	3,120 lm	2,920 lm	700 mA	33.3 V	38.5 V	24.9 W	125 lm/W	120 lm/W	>80
CLE G1 160mm 3000lm 840 SNC	89602911	840/459	3,249 lm	3,035 lm	700 mA	33.3 V	38.5 V	24.9 W	130 lm/W	125 lm/W	>80
CLE G1 315mm 4000lm 830 SNC	89602912	830/459	4,057 lm	3,782 lm	900 mA	32.7 V	37.8 V	31.5 W	129 lm/W	123 lm/W	>80
CLE G1 315mm 4000lm 840 SNC	89602913	840/459	4,231 lm	3,953 lm	900 mA	32.7 V	37.8 V	31.5 W	134 lm/W	129 lm/W	>80

²⁾ If mounted with M4 screws and plastic washers.³⁾ Tolerance of useful light flux - 0 % / + 15 %. Measurement uncertainty ± 10 %.⁴⁾ Tolerance of expected light flux - 0 % / + 15 %. Measurement uncertainty ± 10 %. Based on calculation.⁵⁾ Tolerance of power consumption $P_{on} \pm 10$ %. Measurement uncertainty ± 5 %.

1. Standards

IEC 62031
IEC 62471
IEC 62778
IEC 61547

1.1 Photometric code

Key for photometric code, e. g. 830 / 359

1 st digit	2 nd + 3 rd digit	4 th digit	5 th digit	6 th digit	
Code	CRI	Colour temperature in Kelvin x 100	MacAdam initial	MacAdam after 25% of the lifetime (max.6000h)	
7	70 – 79			Code	Luminous flux
8	80 – 89			7	≥ 70 %
9	≥90			8	≥ 80 %
				9	≥ 90 %

1.2 Energy classification

Type	Colour temperature	Forward current	Energy classification	Energy consumption
CLE G1 50mm 1000lm 830 SNC	3,000 K	100 mA	E	8 kWh / 1,000 h
CLE G1 50mm 1000lm 840 SNC	4,000 K	100 mA	E	8 kWh / 1,000 h
CLE G1 80mm 2000lm 830 SNC	3,000 K	100 mA	E	16 kWh / 1,000 h
CLE G1 80mm 2000lm 840 SNC	4,000 K	100 mA	E	16 kWh / 1,000 h
CLE G1 120mm 2500lm 830 SNC	3,000 K	200 mA	E	22 kWh / 1,000 h
CLE G1 120mm 2500lm 840 SNC	4,000 K	200 mA	E	22 kWh / 1,000 h
CLE G1 160mm 3000lm 830 SNC	3,000 K	200 mA	E	25 kWh / 1,000 h
CLE G1 160mm 3000lm 840 SNC	4,000 K	200 mA	E	25 kWh / 1,000 h
CLE G1 315mm 4000lm 830 SNC	3,000 K	200 mA	E	32 kWh / 1,000 h
CLE G1 315mm 4000lm 840 SNC	4,000 K	200 mA	E	32 kWh / 1,000 h

Energy label and further information at www.tridonic.com in the certificates tab of the corresponding product page and at the EPREL data base <https://eprel.ec.europa.eu/>

2. Thermal details

2.1 tp point, ambient temperature and lifetime

The temperature at tp reference point is crucial for the light output and lifetime of a LED product.

For CLE a tp temperature of 65°C has to be complied in order to achieve an optimum between light output and lifetime.

Compliance with the maximum permissible reference temperature at the tc point must be checked under operating conditions in a thermally stable state. The maximum value must be determined under worst-case conditions for the relevant application.

The tc and tp temperature of LED modules from Tridonic are measured at the same reference point.

2.2 Storage and humidity

Storage temperature	-30... +80 °C
---------------------	---------------

Operation only in non condensing environment.

Humidity during processing of the module should be between 30 to 70 %.

2.3 Thermal design and heat sink

The rated life of LED products depends to a large extent on the temperature. If the permissible temperature limits are exceeded, the life of the CLE will be greatly reduced or the CLE may be destroyed.

2.4 Heat sink values

CLE G1 50mm 1000lm

ta	tp	Forward current	R _{th, hs-a}	Cooling area
25°C	65°C	350 mA	7.48 K/W	89 cm ²
35°C	65°C	350 mA	5.61 K/W	119 cm ²
45°C	65°C	350 mA	3.74 K/W	178 cm ²

CLE G1 80mm 2000lm

ta	tp	Forward current	R _{th, hs-a}	Cooling area
25°C	65°C	700 mA	3.78 K/W	176 cm ²
35°C	65°C	700 mA	2.84 K/W	235 cm ²
45°C	65°C	700 mA	1.89 K/W	353 cm ²

CLE G1 120mm 2500lm

ta	tp	Forward current	R _{th, hs-a}	Cooling area
25°C	65°C	600 mA	2.81 K/W	237 cm ²
35°C	65°C	600 mA	2.10 K/W	317 cm ²
45°C	65°C	600 mA	1.40 K/W	476 cm ²

CLE G1 160mm 3000lm

ta	tp	Forward current	R _{th, hs-a}	Cooling area
25°C	65°C	700 mA	1.65 K/W	404 cm ²
35°C	65°C	700 mA	1.24 K/W	539 cm ²
45°C	65°C	700 mA	0.82 K/W	810 cm ²

CLE G1 315mm 4000lm

ta	tp	Forward current	R _{th, hs-a}	Cooling area
25°C	65°C	900 mA		self-cooling
35°C	65°C	900 mA		self-cooling
45°C	65°C	900 mA		self-cooling

Notes

The actual cooling can differ because of the material, the structural shape, outside influences and the installation situation. A thermal connection between CLE G3 and heat sink with heat-conducting paste or heat conducting adhesive film is absolutely necessary.

Additionally the CLE G3 has to be fixed on the heat sink with M3 screws to optimise the thermal connection.

Use of thermal interface material with thermal conductivity of $\lambda > 1$ W/mK and layer thickness of interface material with max. 50 μ m or a similar interface material where the quotient of layer thickness and thermal conductivity $b < 50$ μ mK/W.

3. Installation / wiring

3.1 Electrical supply/choice of LED driver

CLE from Tridonic are not protected against overvoltages, overcurrents, overloads or short-circuit currents. Safe and reliable operation can only be guaranteed in conjunction with a LED driver which complies with the relevant standards.

If a LED driver other than from Tridonic is used, it must provide the following protection:

- Short-circuit protection
- Overload protection
- Overtemperature protection



CLE must be supplied by a constant current LED driver. Operation with a constant voltage LED driver will lead to an irreversible damage of the module.

Wrong polarity can damage the CLE.

With parallel wiring tolerance-related differences in output are possible (thermal stress of the module) and can cause differences in brightness. If one module fails, the remaining modules may be overloaded.

CLE have to be operated with a SELV LED driver.



CLE are basic insulated up to 60 V SELV against ground and can be mounted directly on earthed metal parts of the luminaire. If the max. output voltage of the LED driver (also against earth) is above 60 V SELV, an additional insulation between LED module and heat sink is required (for example by insulated thermal pads) or by a suitable luminaire construction.

At voltages > 60 V an additional protection against direct touch (test finger) to the light emitting side of the module has to be guaranteed. This is typically achieved by means of a non removable light distributor over the module.

CLE G1 120mm

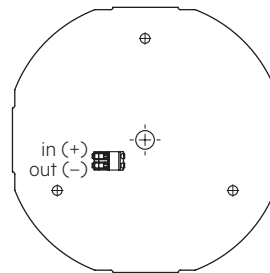

CLE G1 160mm

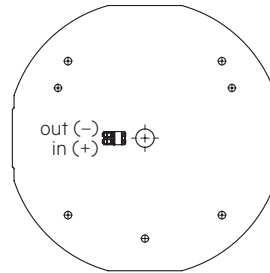

CLE G1 315mm

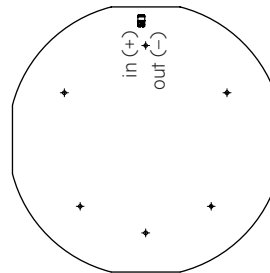

3.2 Wiring

CLE G1 50mm

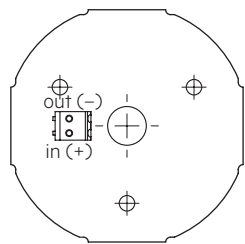

CLE G1 80mm

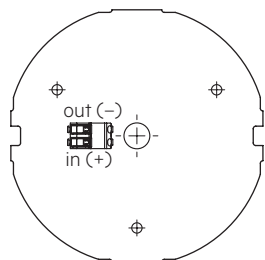

Wiring example

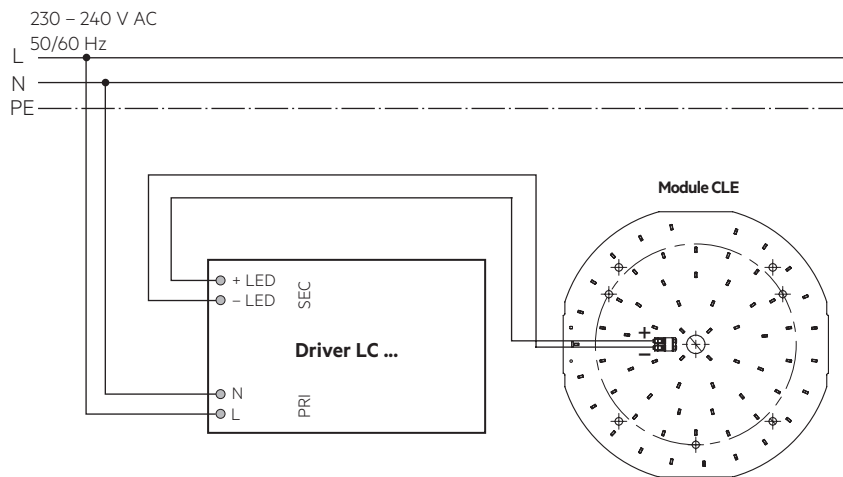

3.3 Wiring type and cross section

The wiring can be solid cable with a cross section of 0.2 to 0.75 mm². For the push-wire connection you have to strip the insulation (7–9 mm). Loosen wire through twisting and pulling.

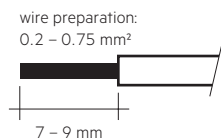

Press down the “push button” and remove the cable from front.

3.4 Mounting instruction



None of the components of the CLE (substrate, LED, electronic components etc.) may be exposed to tensile or compressive stresses.

Max. torque for fixing: 0.5 Nm.

The LED modules are mounted with 4 screws per module. In order not to damage the modules only rounded head screws and an additional plastic flat washer should be used.



Chemical substance may harm the LED module. Chemical reactions could lead to colour shift, reduced luminous flux or a total failure of the module caused by corrosion of electrical connections.

Materials which are used in LED applications (e.g. sealings, adhesives) must not produce dissolver gas. They must not be condensation curing based, acetate curing based or contain sulfur, chlorine or phthalate. Avoid corrosive atmosphere during usage and storage.

3.5 EOS/ESD safety guidelines



The device / module contains components that are sensitive to electrostatic discharge and may only be installed in the factory and on site if appropriate EOS/ESD protection measures have been taken. No special measures need be taken for devices/modules with enclosed casings (contact with the pc board not possible), just normal installation practice. Please note the requirements set out in the document EOS / ESD guidelines (Guideline_EOS_ESD.pdf) at: <http://www.tridonic.com/esd-protection>

4. Lifetime

4.1 Lifetime, lumen maintenance and failure rate

The light output of an LED module decreases over the lifetime, this is characterized with the L value.

L70 means that the LED module will give 70 % of its initial luminous flux. This value is always related to the number of operation hours and therefore defines the lifetime of an LED module.

As the L value is a statistical value and the lumen maintenance may vary over the delivered LED modules.

The B value defines the amount of modules which are below the specific L value, e.g. L70B10 means 10 % of the LED modules are below 70 % of the initial luminous flux, respectively 90 % will be above 70 % of the initial value. In addition the percentage of failed modules (fatal failure) is characterized by the C value.

The F value is the combination of the B and C value. That means for F degradation and complete failures are considered, e.g. L70F10 means 10 % of the LED modules may fail or be below 70 % of the initial luminous flux.

4.2 Lumen maintenance

CLE G1 50mm

Forward current	tp temperature	L90 / F10	L90 / F50	L80 / F10	L80 / F50	L70 / F10	L70 / F50
350 mA	55 °C	24,000 h	28,000 h	44,000 h	53,000 h	>60,000 h	>60,000 h
350 mA	65 °C	23,000 h	27,000 h	42,000 h	52,000 h	>60,000 h	>60,000 h
350 mA	75 °C	22,000 h	27,000 h	40,000 h	52,000 h	>60,000 h	>60,000 h

CLE G1 80mm

Forward current	tp temperature	L90 / F10	L90 / F50	L80 / F10	L80 / F50	L70 / F10	L70 / F50
700 mA	55 °C	24,000 h	28,000 h	44,000 h	53,000 h	>60,000 h	>60,000 h
700 mA	65 °C	23,000 h	27,000 h	42,000 h	52,000 h	>60,000 h	>60,000 h
700 mA	75 °C	22,000 h	27,000 h	40,000 h	52,000 h	>60,000 h	>60,000 h

CLE G1 120mm

Forward current	tp temperature	L90 / F10	L90 / F50	L80 / F10	L80 / F50	L70 / F10	L70 / F50
600 mA	55 °C	24,000 h	28,000 h	44,000 h	53,000 h	>60,000 h	>60,000 h
600 mA	65 °C	23,000 h	27,000 h	42,000 h	52,000 h	>60,000 h	>60,000 h
600 mA	75 °C	22,000 h	27,000 h	40,000 h	52,000 h	>60,000 h	>60,000 h

CLE G1 160mm

Forward current	tp temperature	L90 / F10	L90 / F50	L80 / F10	L80 / F50	L70 / F10	L70 / F50
700 mA	55 °C	24,000 h	28,000 h	44,000 h	53,000 h	>60,000 h	>60,000 h
700 mA	65 °C	23,000 h	27,000 h	42,000 h	52,000 h	>60,000 h	>60,000 h
700 mA	75 °C	22,000 h	27,000 h	40,000 h	52,000 h	>60,000 h	>60,000 h

CLE G1 315mm

Forward current	tp temperature	L90 / F10	L90 / F50	L80 / F10	L80 / F50	L70 / F10	L70 / F50
900 mA	55 °C	24,000 h	28,000 h	44,000 h	53,000 h	>60,000 h	>60,000 h
900 mA	65 °C	23,000 h	27,000 h	42,000 h	52,000 h	>60,000 h	>60,000 h
900 mA	75 °C	22,000 h	27,000 h	40,000 h	52,000 h	>60,000 h	>60,000 h

5. Electrical values

5.1 Typ. forward voltage vs. forward current

CLE G1 150mm

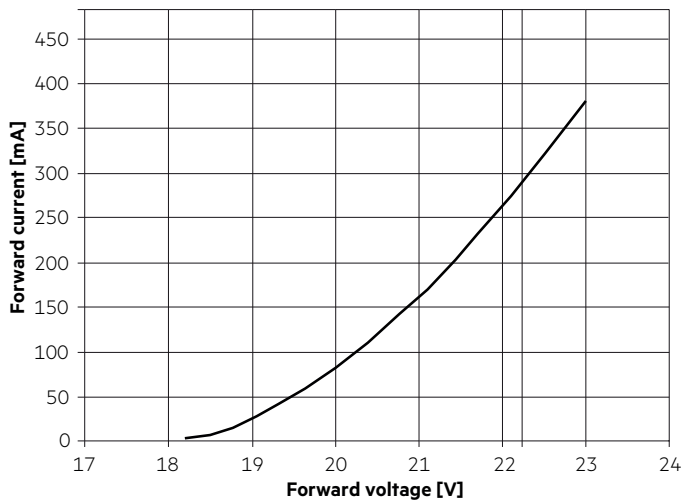

CLE G1 180mm

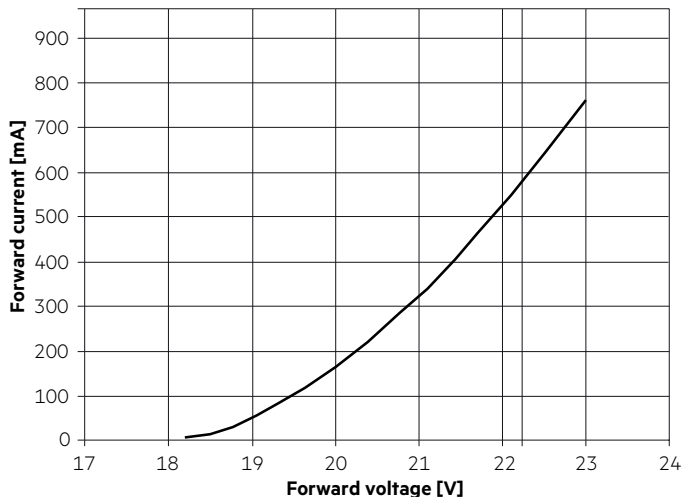

CLE G1 120mm



CLE G1 160mm



CLE G1 315mm

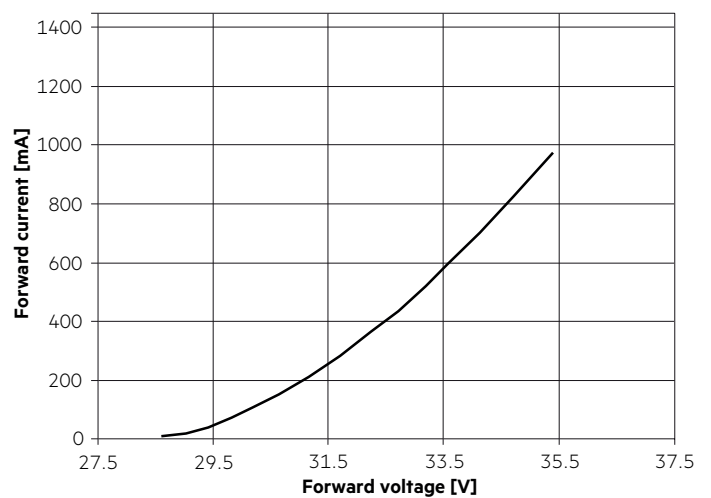

5.2 Forward voltage vs. tp temperature

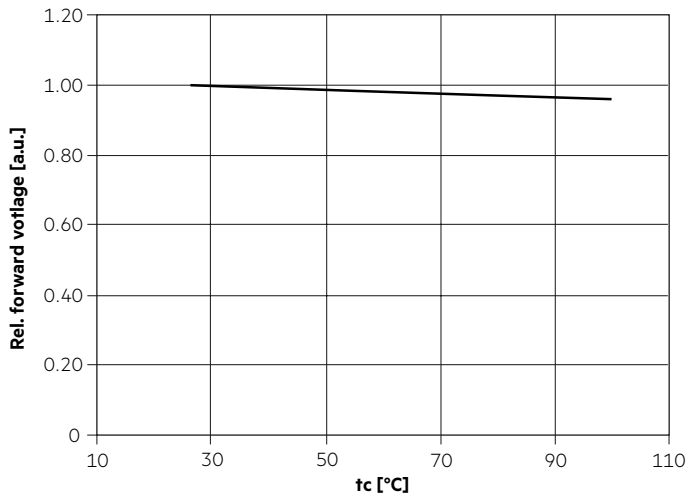

The diagrams based on statistic values. The real values can be different.

6. Photometric characteristics

6.1 Coordinates and tolerances according to CIE 1931

The specified colour coordinates are measured integral by a current impulse with Irated of the module and a duration of 100 ms.
 The ambient temperature of the measurement is $t_a = 25\text{ °C}$.
 The measurement tolerance of the colour coordinates are ± 0.01 .

3,000 K

	x0	y0
Centre	0.4322	0.4024

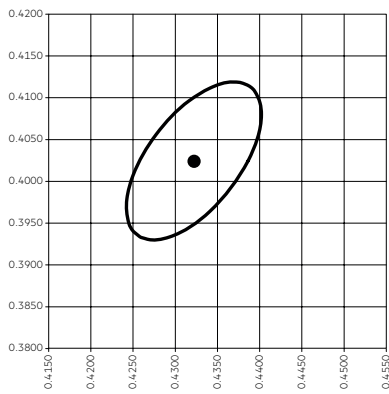

— MacAdam Ellipse: 4SDCM

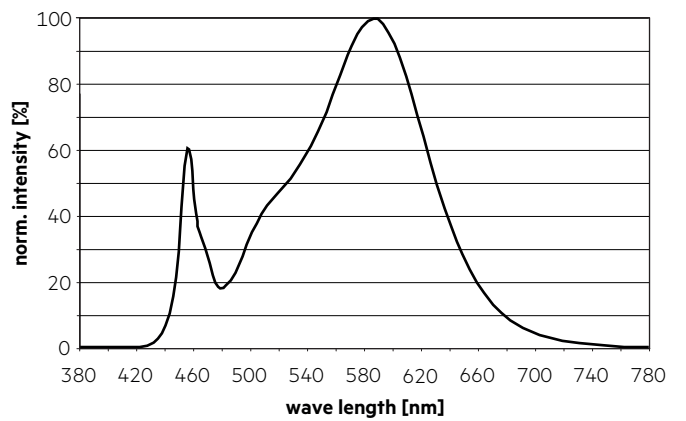

4,000 K

	x0	y0
Centre	0.3805	0.3789

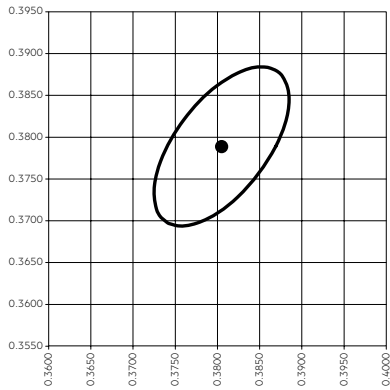

— MacAdam Ellipse: 4SDCM

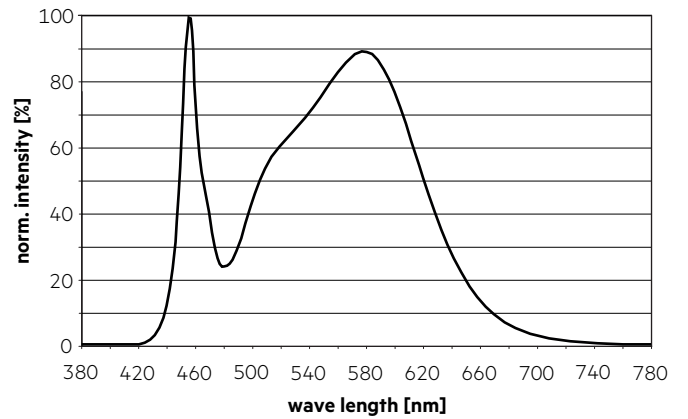

6.2 Light distribution

The optical design of the CLE product line ensures optimum homogeneity for the light distribution.

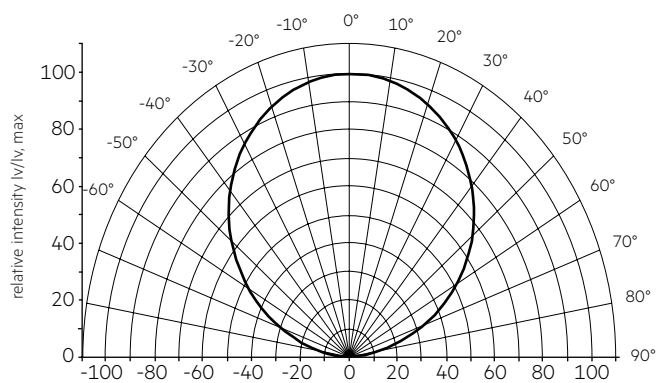

The colour temperature is measured over the complete module. The single LED light points can be outside of 3SDCM. To ensure an ideal mixture of colours and a homogeneous light distribution a suitable optic (e. g. PMMA diffuser) and a sufficient spacing between module and optic (typ. 5 cm) should be used.

6.3 Relative luminous flux vs. tc temperature

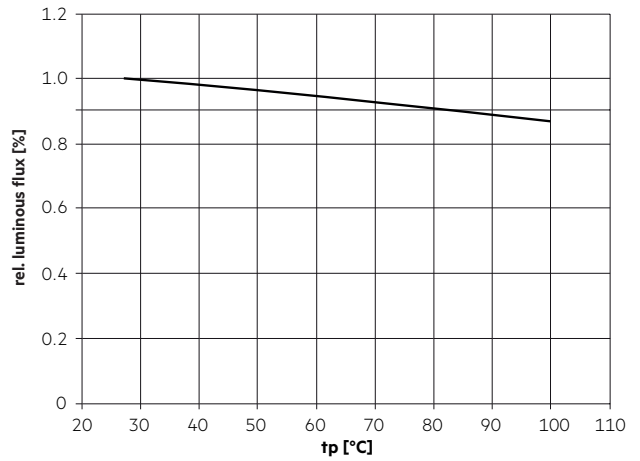

6.4 Relative luminous flux vs. operating current

CLE G1 50mm

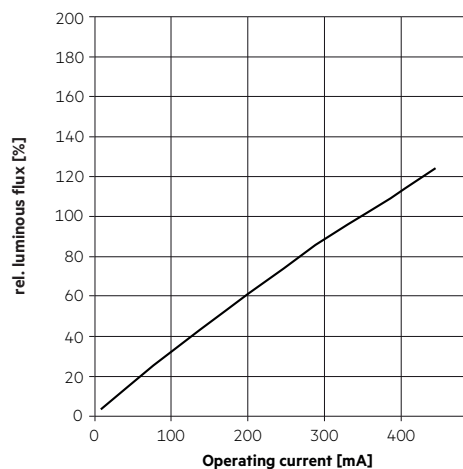

CLE G1 80mm

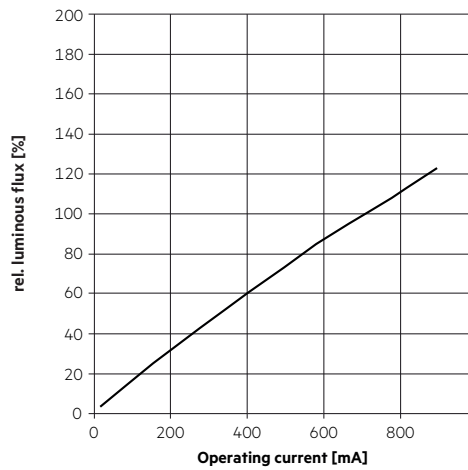

CLE G1 315mm

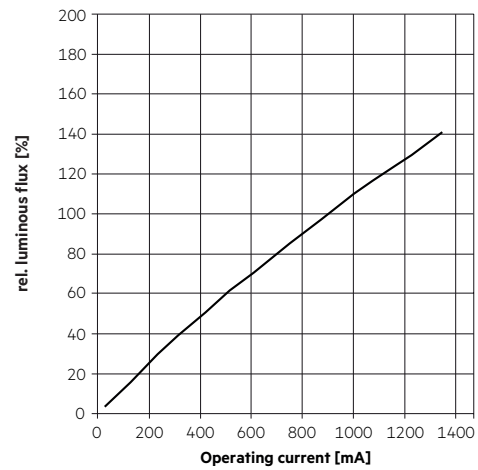

CLE G1 120mm

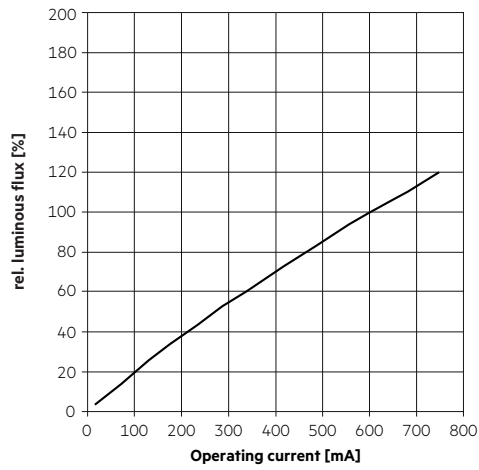

CLE G1 160mm

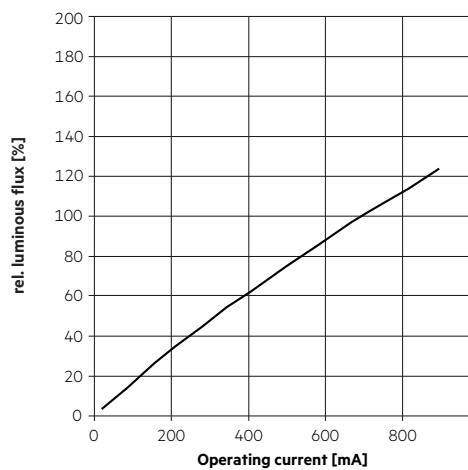

7. Miscellaneous

7.1 Additional information

Additional technical information at www.tridonic.com → Technical Data

Guarantee conditions at www.tridonic.com → Services

Lifetime declarations are informative and represent no warranty claim.