

LiFePO4 Accus 3.3 – 6.6 Ah

Lithium Iron Phosphate cells (LiFePO4)



Stick



Side by side, 4 cells

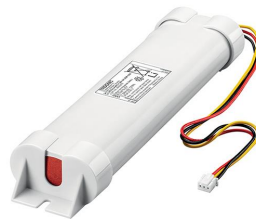

Side by side, 6 cells

Product description

- _ High-temperature LiFePO4 cells only for use with Tridonic emergency lighting units
- _ LiFePO4: up to 12 years design life
- _ 8 years guarantee for LiFePO4 batteries (conditions at <https://www.tridonic.com/en/int/services/manufacturer-guarantee-conditions>)

Properties

- _ Environmental friendly technology
- _ High energy density
- _ Low profile cross-section with removable end caps
- _ Constant high-temperature operation
- _ Good charging properties at high temperature
- _ Electronic thermal battery management
- _ High energy maintenance of the charged battery
- _ Long shelf life
- _ Integrated electronics
- _ Safety features incorporated
- _ Certified quality manufacturer
- _ In various configurations
- _ Simple connection with plug-in system
- _ With polycarbonate fixing caps
- _ Suitable for emergency lighting equipment as per IEC 60598-2-22

Website

<http://www.tridonic.com/28005171>

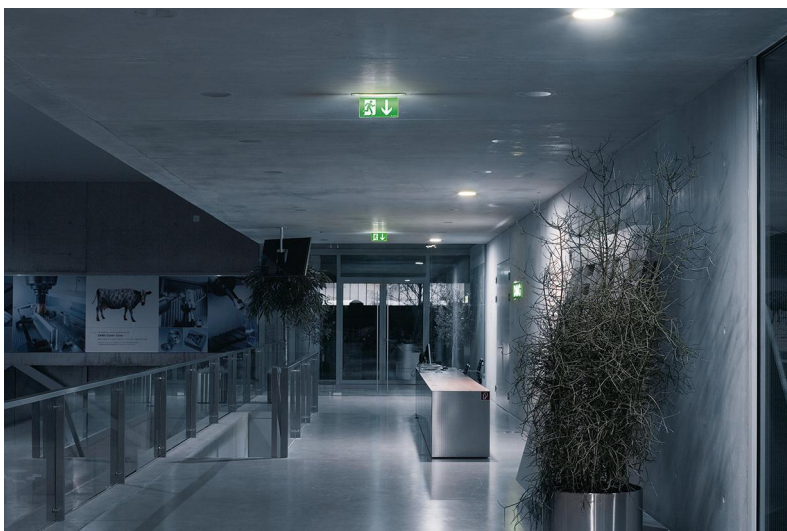

LiFePO₄ Accus 3.3 – 6.6 Ah

Lithium Iron Phosphate cells (LiFePO₄)

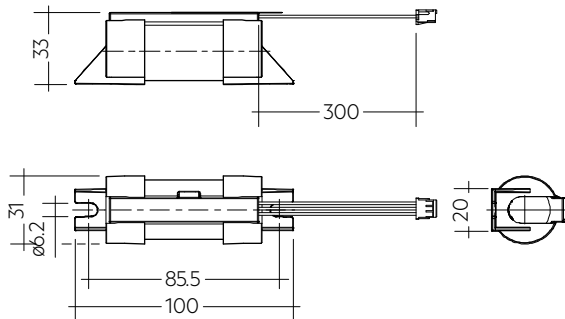

Stick, 1 cell

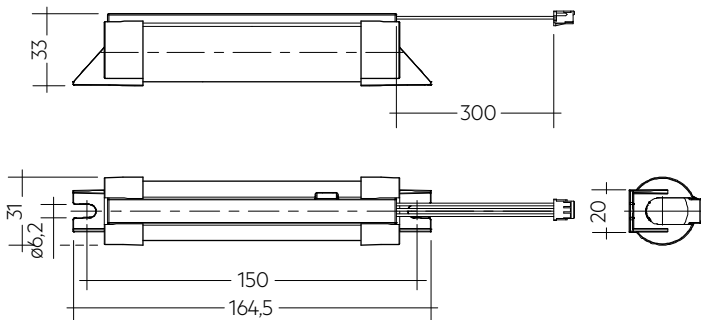

Stick, 2 cells

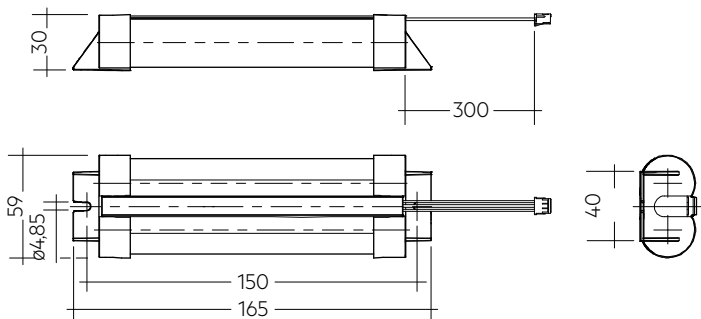

Side by side, 4 cells

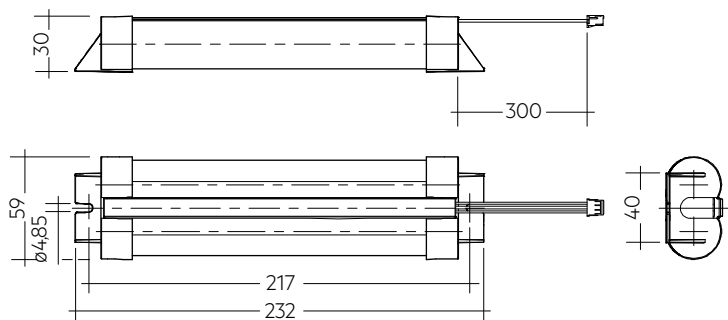

Side by side, 6 cells

Ordering data

Type	Article number	Capacity	Packaging, carton	Packaging, outer box	Weight per pc.
ACCU-LiFePO4 3.3Ah 1A 1S1P CON	28005171	3.3 Ah	5 pc(s).	-	0.100 kg
ACCU-LiFePO4 3.3Ah 2A 2S1P CON	28003814	3.3 Ah	5 pc(s).	25 pc(s).	0.232 kg
ACCU-LiFePO4 6.6Ah 4A 2S2P CON	28003815	6.6 Ah	5 pc(s).	25 pc(s).	0.412 kg
ACCU-LiFePO4 6.6Ah 6A 3S2P CON	28003816	6.6 Ah	5 pc(s).	25 pc(s).	0.600 kg

Technical data

Battery voltage per cell	3.2 V
Battery capacity per cell ^①	3.6 Ah
Min. battery casing temp. (design life of 4 – 8 years)	+ 5 °C
Max. battery casing temp. (design life of 4/8 years)	Refer to emergency control gear datasheet

Specific technical data

Type	Article number	Number of cells	Capacity	Dimension s L x W x
ACCU-LiFePO4 3.3Ah 1A 1S1P CON	28005171	1	3.3 Ah	100.0 x 31 x 33 mm
ACCU-LiFePO4 3.3Ah 2A 2S1P CON	28003814	2	3.3 Ah	164.5 x 31 x 33 mm
ACCU-LiFePO4 6.6Ah 4A 2S2P CON	28003815	4	6.6 Ah	165.0 x 59 x 30 mm
ACCU-LiFePO4 6.6Ah 6A 3S2P CON	28003816	6	6.6 Ah	232.0 x 59 x 30 mm

^① For article number 28005171 3.3 Ah applies.

1. Standards

The battery cells are designed to comply with the IEC international standard and tested according to the normative permanent charge endurance test described in the IEC 62133 standard. This performance is mandatory for use in Emergency Lighting Units to comply with the IEC 60598-2-22.

1.1 Glow-wire test

according to EN 61347-1 with increased temperature of 850 °C passed (valid for connectors and caps).

2. Thermal data

2.1 Storage conditions

- Store batteries within the specified temperature range in low humidity conditions. Optimal storage conditions are:
 - Temperature: -20... +35 °C up to 15 months after printed date of manufacture
 - Relative humidity: 60 ± 5 %
- Avoid atmosphere with corrosive gas
- Disconnect batteries before store or delivery
- Avoid storage of discharged batteries

3. Installation & commissioning

3.1 Activating LiFePO₄ batteries

When using rechargeable LiFePO₄ batteries for emergency lighting following point are essential in order to achieve the specified design life time of the batteries:

In order to activate new batteries, 2-3 full charging-discharging are needed to make sure batteries achieve their rated capacity. This activating process is defined by running 2-3 full charging (24 hrs) and discharging (1/2/3 hrs) cycles of the batteries. If the first duration test fails, please repeat the test once again after a 24 hour charging period.

3.2 Avoidance of excessive cycling

During building installations, in many cases, mains supply is not available on a permanent 24-hour basis which then leads to unwanted, uncontrolled excessive battery cycles. This has a very strong effect on the design life time of the battery. Make sure that in such situations, the battery remains disconnected in the luminaire till the mains power supply is stable on a 24-hour basis. It is strongly recommended to refer to the datasheets of Tridonic emergency control gears to avoid excessive cycling. At the same time, make sure that this information is handed over to the installation staff / electrician in order to ensure a proper way of installation and commissioning.

3.3 Avoidance of deep-discharge conditions

It is very important that LiFePO₄ batteries are not left connected for long periods in a discharged state. Following options may lead to a deep discharge situation and must be avoided:

- Storage periods of rechargeable batteries of over 6/15 month without recharging the battery.
- Shipment, storage of assembled emergency luminaires with battery connected to the emergency driver.
- Long periods of mains-interruptions of more than two weeks, once the emergency system is installed and the battery is connected to the emergency driver.

3.4 Thermal sensor

Battery has built in thermal sensor for safe charging. Mount battery away from heat source.

3.4.1 Position of thermal sensor

Stick, 1 or 2 cells (1A, 2A):

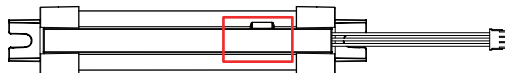

Side by side, 4 cells (4A):

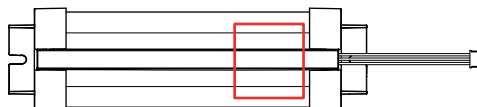

Side by side, 6 cells (6A):

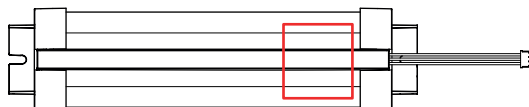

4. Mechanical details

4.1 Battery leads and connection

Max. length: 800 mm

- 300 mm on battery side with connector to connect into the Emergency lighting unit
- 500 mm with connectors on both sides to extend the battery wiring to max. 800 mm (separate article number)

5. Technical data Cell

Capacity	
Rated minimum capacity	3.3 Ah
Typical weight per cell	90 g
Cell dimensions	
Diameter	26 mm
Height	65 mm

Consult individual emergency control gear data sheet for maximum allowable temperatures and allowed number of discharge cycles.

6. Safety



- Do not short-circuit the battery – when installing the luminaire make sure sharp edges do not come into contact with cables.
- Do not open or damage the battery or throw it into a fire.
- Protect the battery against moisture and keep away from water.
- Do not expose the battery to direct sunlight or excessive heat (See storage conditions).
- Transport and store the battery only in its original packaging.
- Comply with the transport conditions of the transport company.
- Follow the instructions on the safety data sheets.



Damage/improper use

If the battery is damaged or used incorrectly vapours and liquids may escape from it. If you come into contact with battery fluid wash immediately with water and seek medical assistance if necessary.

6.1 Deep discharge protection

When the battery remains connected without charging for a long period of time after the battery cut off of the driver the battery voltage can still drop. To make sure the cells are not damaged by this voltage drop, the battery protection prevents the battery from further discharge below 2.0 V.

6.2 Overcharge protection

If in case of an error or the use of a wrong driver the battery gets overcharged the battery protection will disconnect the battery from the driver at a voltage of 3.9 V. A discharge of the battery is still possible after the protection circuit was triggered to guarantee emergency operation.

6.3 Short-circuit protection

In case of a short circuit the battery protection opens the connection to the driver and the output is therefore free of voltage. The output will be reactivated again when the short circuit is removed.

7. Disposal

- Do not dispose of batteries with normal waste.
- Comply with local regulations when disposing of batteries.

8. Miscellaneous

8.1 Additional information

Additional technical information at www.tridonic.com → Technical Data

No warranty if battery was opened.