

FSensor SSI 31 2XPIR 8DP DG bDW

Casambi Ready wireless modules

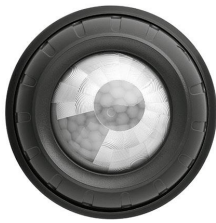

Product description

- _ Monitoring of ambient light and occupancy detection
- _ Can be integrated in Casambi systems (Casambi Ready)
- _ Wireless controllable with an Android / iOS smart device
- _ Forms automatically a wireless communication network with up to 250 nodes
- _ Digital output to control IEC 62386 compatible drivers
- _ Additional mounting from the outside possible
- _ Low energy consumption over bus supply
- _ Ready for Zhaga Book 18 Ed. 3 receptacle for easy and flexible installation to luminaire
- _ Rectangular detection area ideal for street applications
- _ Pressure equalizing membrane built-in
- _ Lifetime up to 50,000 h at $t_c = 60^\circ\text{C}$
- _ 5 years guarantee (conditions at <https://www.tridonic.com/en/int/services/manufacturer-guarantee-conditions>)
- _ We will provide security updates for the next five years after the date of purchase of this product

Housing properties

- _ Casing: Dark grey (RAL 7040)
- _ Type of protection up to IP66
- _ Impact protection degree IK08 (lens excluded)

Benefits

- _ Simplified luminaire design: By integrating a bDW node into the PIR sensor in a single device, only one Zhaga socket is required
- _ Flexible: Individual adjustment of parameters with configuration software
- _ Integrated solution: Combines connected luminaires and light-on-demand functionality in a single device

Typical applications

- _ Rectangular detection area ideal for street application at 4 to 8 m mounting height
- _ Car parks, parks, cycle paths, walkways

Website

<http://www.tridonic.com/28006351>



FSensor SSI 31 2XPIR 8DP DG bDW
Casambi Ready wireless modules

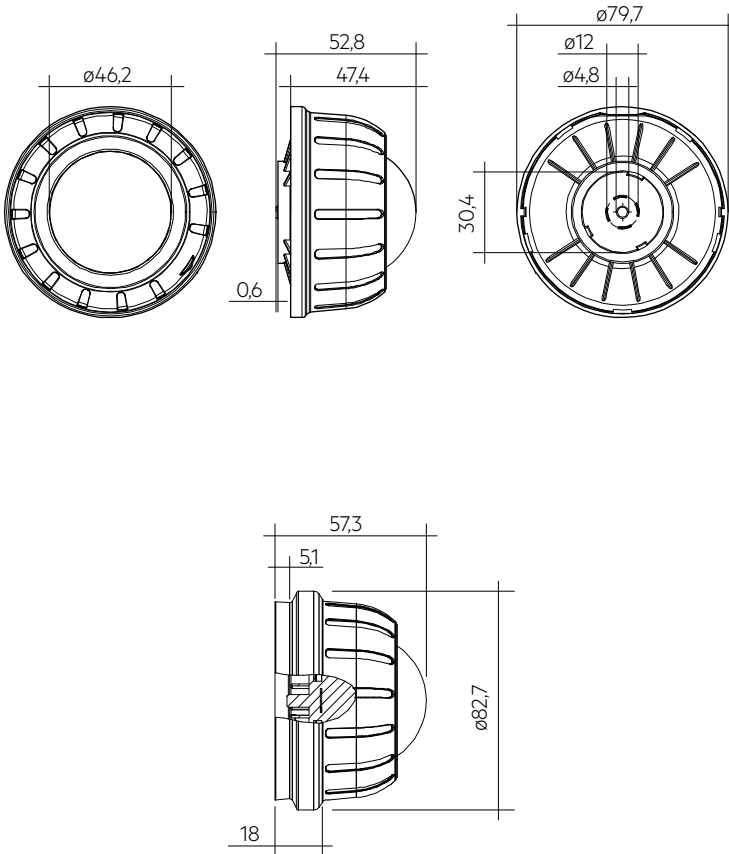

Ordering data

Type	Article number	Suitable for	Packaging, carton	Weight per pc.
FSensor SSI 31 2XPIR 8DP DG bDW	28006351	Street & Road lighting	20 pc(s).	0.13 kg

Technical data

Sensor type	Movement and light sensor
Supply via	IEC 62386 compatible power supply
Supply voltage ^①	9.5 – 22.5 V
Current consumption (no LED)	max. 15 mA
Current consumption (with LED)	max. 16 mA
Starting time	30 s
Mounting height	4 – 8 m
Mounting hole	acc. to Zhaga Book 18 Ed. 3
Type of installation ^②	Zhaga Book 18 Ed. 3 socket
Presence detection area at 6 m height	26 m x 12 m = 312 m ²
Detection angle for light measurement	76°
Detection range for light measurement ^③	1 – 4,000 lx
Min. temperature difference between ambient temperature and detected object	± 4 °C
Radio transceiver operating frequencies	2.4 – 2,483 GHz
Max. output power radio transceiver (E.I. R.P.) ^④	< + 20 dBm
Radio protocol	Bluetooth 4.0
Capable for mesh network	Up to 250 nodes
Interface	Digital interface according to IEC 62386
Ambient temperature ta ^⑤	-20 ... +50 °C
tc point	60 °C
Storage temperature ts	-20 ... +60 °C
Humidity	0 ... 90 %
Dimensions Ø x H	Ø 79.7 x 52.8 mm
Diameter with dust and dirt protection	Ø 82.7 mm
Height with dust and dirt protection	57.3 mm
Housing material body	Lexan 923
Housing material lens	HDPE
Housing colour body	Dark grey (RAL 7040)
Housing colour lens	Transparent white
Type of protection	IP66
Impact protection degree ^⑥	IK08

Approval marks

① Uin acc. IEC 62386-101.

② Device must be installed on the bottom side of the luminaire.

③ The measured value at the sensor head corresponds to 20 – 90 % of the lux value measured on the surface located below the sensor.

④ E.I.R.P.: Equivalent Isotropically Radiated Power.

⑤ Correct sensor operation can not be guaranteed if operated outside this ta window.

⑥ It is essential to mount the plug connection (AZU Z18 Set) and sensor correctly to achieve the full IK rating. These impact protection degree does not apply to the lens.

ACU Z18 G2 Set

Accessory



ACU Z18 REP 4PIN G2



ACU Z18 CAP IP66 G2



ACU Z18 REP 4PIN + ACU Z18 CAP IP66

Product description

- _ Set consisting of receptacle, lock washer and mounting nut (ACU Z18 REP 4PIN G2)
- _ Designed for street lighting control
- _ Double connector terminal for an easy through wiring to two DALI nodes simultaneously
- _ Colored dots for a quick and failure free assembly (matching with LCO PRE3 and LCO 2 channel outdoor driver terminals)
- _ Compliant with Zhaga Book 18 Ed. 3
- _ UL UV-f1 rated for outdoor use
- _ IK09 high impact resistant

Housing properties

- _ Colour: dark grey (RAL 7043)
- _ Casing receptacle: PBT
- _ Type of protection IP66

Note

- _ Please consider correct placing of the gasket lip in the gasket seat. For details refer to data sheet chapter „Gasket varification“

Interfaces

- _ Supplies Zhaga Book 18 Ed. 3 contact system

Website

<http://www.tridonic.com/28005366>



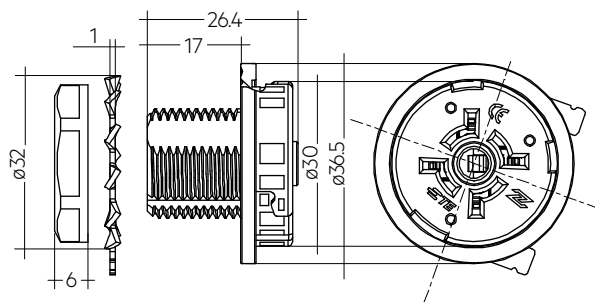

ACU Z18 REP 4PIN G2

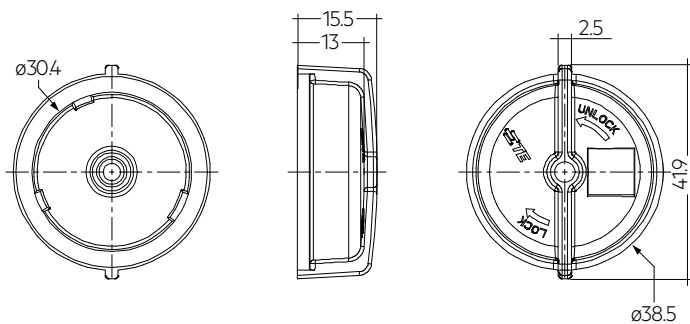

ACU Z18 CAP IP66 G2

Ordering data

Type	Article number	Packaging, carton	Packaging, bag	Weight per pc.
ACU Z18 REP 4PIN G2	28005366	200 pc(s).	-	0.027 kg
ACU Z18 CAP IP66 G2	28005374	200 pc(s).	100 pieces	0.009 kg

Approval marks



ACU Z18 Set

Accessory

**Product description**

- _ Set consisting of receptacle, lock washer and mounting nut (ACU Z18 REP 4PIN)
- _ Designed for street lighting control
- _ Compliant with Zhaga Book 18 Ed. 3
- _ Optional IP66 with sealing cap (ACU Z18 CAP IP66)
- _ UL UV-f1 rated for outdoor use
- _ Impact protection degree IK09
- _ For more details see data sheet ACU Z18 Set

Housing properties

- _ Colour: dark grey (RAL 7043)
- _ Casing receptacle: PBT
- _ Type of protection IP20

Interfaces

- _ Supplies Zhaga Book 18 Ed. 3 contact system

Website

<http://www.tridonic.com/28003209>

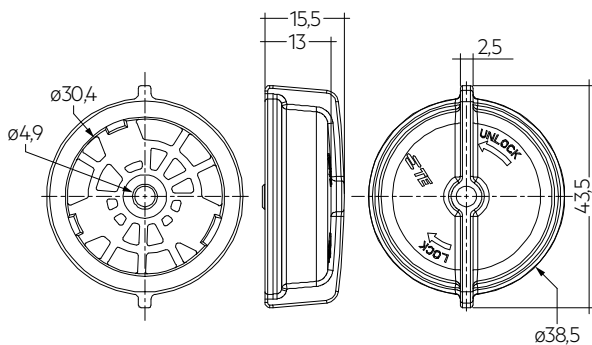
**Ordering data**

Type	Article number	Packaging, bag	Weight per pc.
ACU Z18 REP 4PIN	28003209	100 pieces	0.021 kg
ACU Z18 CAP IP66	28003208	100 pieces	0.020 kg

Approval marks

ACU Z18 SKIRT 80mm

Accessory



ACU Z18 SKIRT BLACK 80MM



ACU Z18 SKIRT GREY 80MM

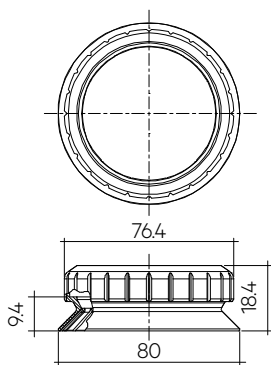

Product description

- _ Accessory to protect the Zhaga book 18 Ed.3 connection between socket and node from dust and dirt
- _ Accessory is included in the product, but if it get lost or damaged it can be ordered separately

Website

<http://www.tridonic.com/28005593>



Ordering data

Type	Article number	Colour	Diameter	Packaging, carton	Weight per pc.
ACU Z18 SKIRT GREY 80MM	28005593	Grey	80 mm	500 pc(s).	0.008 kg
ACU Z18 SKIRT BLACK 80MM	28005594	Black	80 mm	500 pc(s).	0.008 kg

1. Standards

EN 55015
EN 61347-1
EN 61347-2-11
EN 61547
EN 62493
EN 62479
EN 300 328
EN 301 489-1
EN 301 489-17

1.1 Glow wire test

according to EN 61347-1 passed with 750 °C.

2. Common

The Tridonic FSensor SSI 31 2XPIR 8DP DG bDW is one of the first motion sensor developed especially to fit perfectly in Urban Outdoor Applications. The FSensor SSI 31 2XPIR 8DP DG bDW is one of the new generation of Tridonic Bluetooth modules.

With its PIR technology elements the FSensor allows a wide detection range of typical streets and supporting a coverage area at 8 m height of up to 35 m x 16 m = 560 m².

The innovative platform design of the sensor enables easy plug and play by supporting the Zhaga Book 18 Ed. 3. The flexible mounting height from 4 – 8 m allows in addition a huge variation of use-cases to be covered. Next to its robust design and long lifetime the IP66 rating complement an excellent protection against harsh outdoor environment.

The sensor is powered by a IEC 62386 compatible power supply.

All basicDIM Wireless devices can be controlled with the Tridonic app "4remote BT". The app can be downloaded free of charge from the Apple App Store and Google Play Store.

2.1 Operation

The FSensor SSI 31 PIR 8DP DG bDW is fully compatible with networks which support up to 250 nodes (Evolution networks). If the modul is used with different types of basicDIM Wireless devices in an Evolution network, their compatibility has to be checked before.

Multiple devices automatically form a mesh network that can be controlled from any point. These networks communicate wirelessly directly with the smartphone or tablet. Therefore, an external gateway or wireless LAN network is not needed.

basicDIM Wireless devices can be used very flexible for different use cases. The operating modes (profiles) can be changed in the 4remote BT app.

3. Installation

- The FSensor must not be connected to mains. It is supplied directly via the BUS power supply.
- BUS is not SELV. The installation instructions for mains voltage therefore apply.
- Please ensure that the detection ranges of the sensors do not overlap. This may have influence to the light measurement.
- When installed at another height than the recommended installation height, the presence sensor might show different characteristics. When mounted at a higher level, the sensitivity is reduced. If mounted at a lower level, the range is reduced.
- Heat sources located in the detection zone may cause incorrect presence detection.
- The triangular sign indicates the direction to the street (Zhaga y axis) when the sensor is locked in place.
- FSensor is developed to cover the mentioned detection area. Depending on the environment, sensor may also detect objects located outside the mentioned detection area.
- Correct sensor operation can not be guaranteed if operated outside his ta window.
- Make sure the sensor is mounted correctly and locked in place.
- Motions of the pole may trigger the sensor.
- The detection range can be reduced if the sensor is mounted too close to the pole.
- Sensor may be triggered by nearby trees, branches or smaller animals.
- Min. temperature difference between ambient temperature and detected object is $\pm 4^{\circ}\text{C}$. Objects inside this window may not be detected by the sensor.
- Avoid direct illumination of the light source on the sensor including housing.

3.1 Placement

Maximum radio range may be reduced if objects are located between the RFNodes or the RFNode is covered with dirt, dust, foliage and other impurities.

Max. radio range:

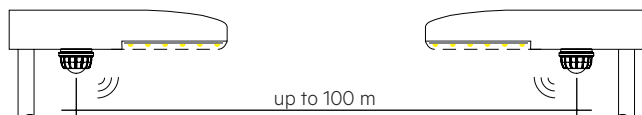

The range of the radio signal depends on the environment, weather conditions, installation height and network mode. The influence of e.g. buildings, trees or bridges between the individual RFNodes as well as specific weather conditions such as rain and snow must be checked and accepted on site.
 Network mode better performance: up to 50 m
 Network mode balanced: up to 100 m
 Network mode long range: > 100 m



To ensure a good radio connection, do not cover the FSensor with any materials!

3.2 Wiring

For EN 62386-101 Ed. 2 systems:

Wiring diagram with an internal bus supply

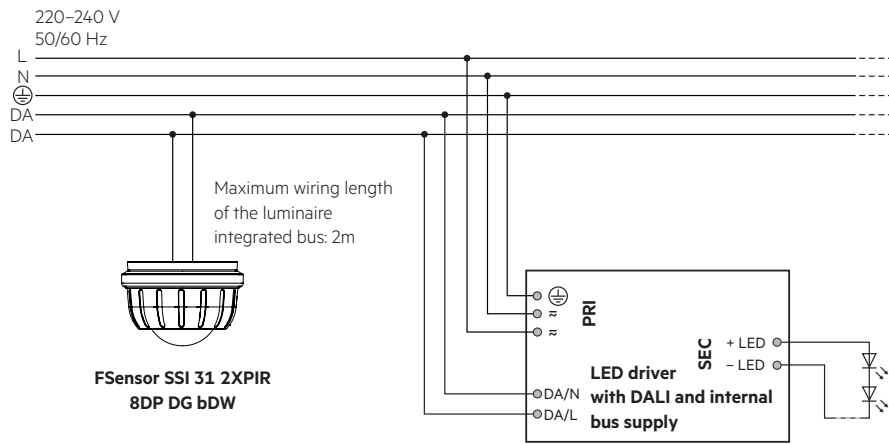

Wiring diagram with an external bus supply

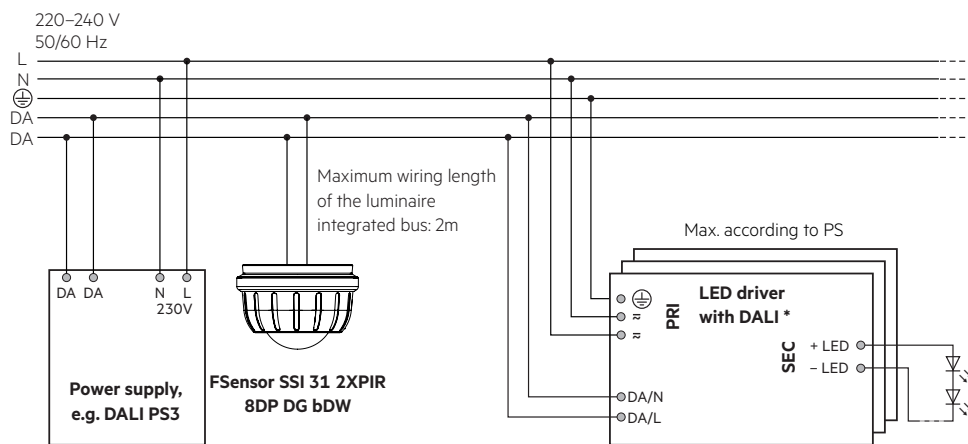

* Max. 4 single / group addresses (A0 ... A3 / G0 ... G3) controllable, depending on the device profile of the basicDIM Wireless module.
The rest of the connected drivers can be controlled via broadcast – depending on the device profile.

OTD system overview:

The sensor is optimized to be used in combination with Tridonic LED driver PRE3 with internal power supply.

Following illustration visualizes the wiring of the components inside the luminaire.

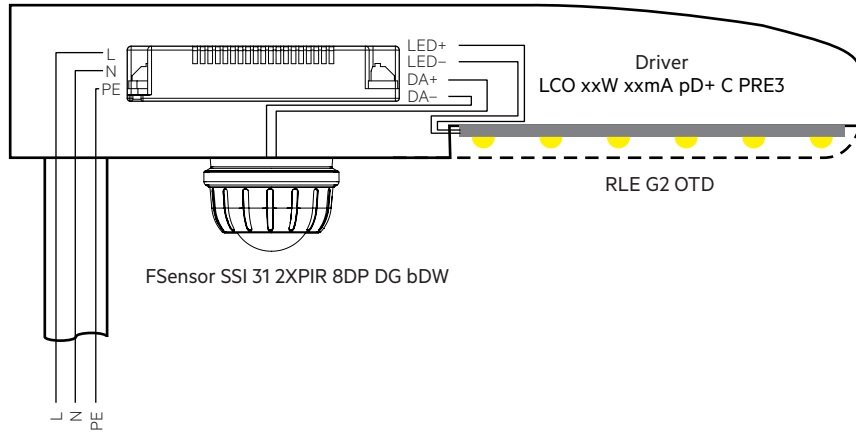

The sensor supports the Zhaga connectivity standard for Plug and Play luminaire extensions. This allows a toolless and flexible integration in luminaires. The connection interface is designed according to Zhaga Book 18 Ed. 3.

Pin assignment FSensor

Pins	Assignment
Pin 1	Not connected
Pin 2*	Negative Pole BUS
Pin 3*	Positive Pole BUS
Pin 4	Not connected

* The polarity is not mandatory for function of the sensor, but is mentioned because the receptacle has to be designed according to Zhaga Book 18 Ed. 3 and inside the luminaire the polarity has to be wired correctly.



The Zhaga connector pins mounted in the luminaire, have to follow the same pin assignment as described in Zhaga Book 18 Ed. 3!

3.3 Mounting instructions

Assembly visualization, see data sheet AZU Z18 Set too:

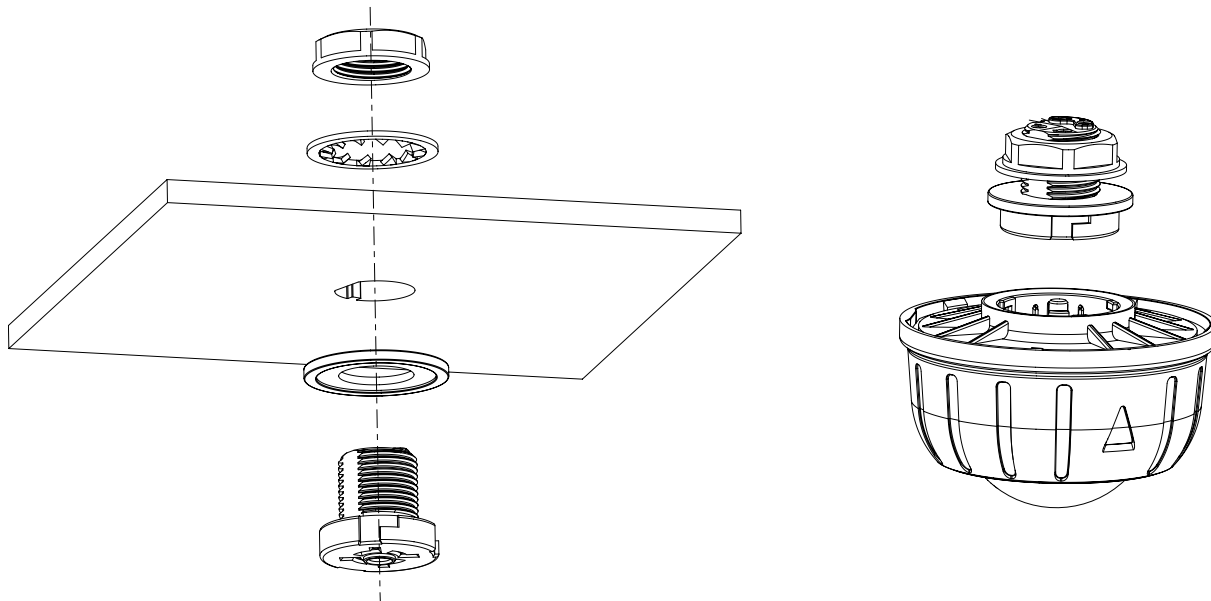

Zhaga Book 18 Ed. 3 axis description:

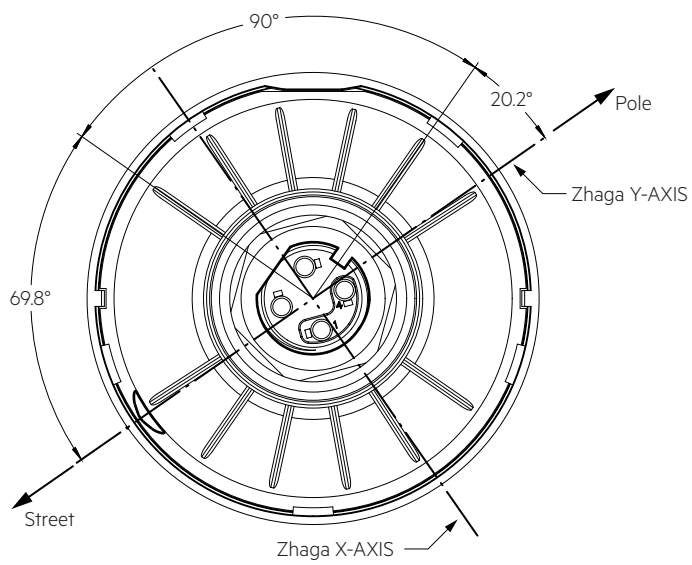

Installation on luminaire:

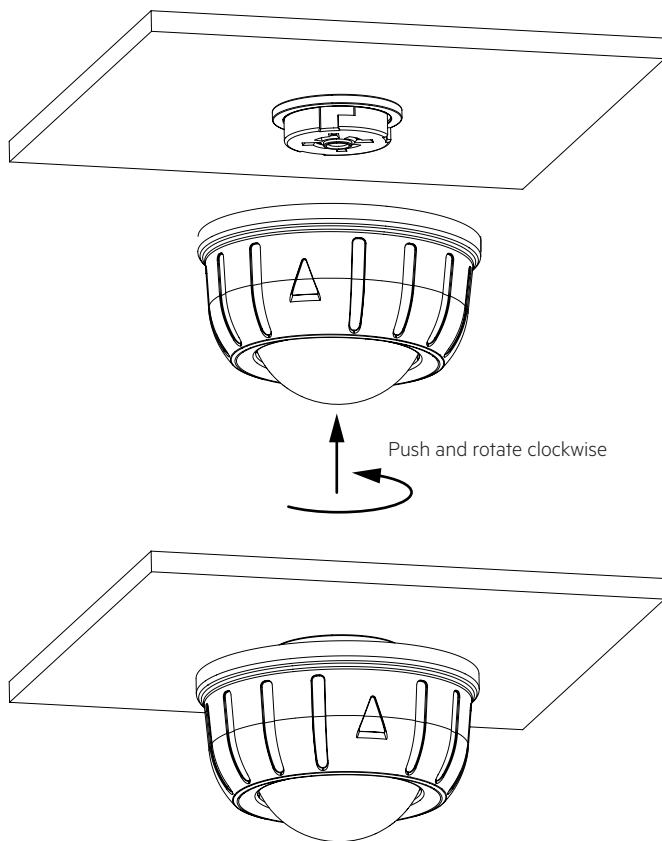

The triangular sign indicates the direction to the street (Zhaga y axis) when the sensor is locked in place. The sensor must lock.

Make sure that the dust and dirt protection, is not bent, no foreign parts between the seal and the fixture housing are located and that the protection fits the fixture.

3.4 QR Code

On the bottom of the sensor an QR Code is located. The QR Code can be scanned with Tridonic Service App and will provide additional Information about the Sensors like e.g. Batch Number.

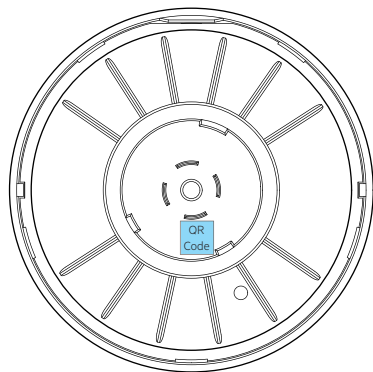



4. Sensor function

4.1 Motion detection

FSensor is designed to be used in urban street lighting application. The sensor lens is designed for 0 degrees tilt, parallel to the road surface. The motion sensor detects a moving object with different surface temperature compared to the background (mainly pedestrians). The PIR technology is used, covering a rectangular area (part of a street).

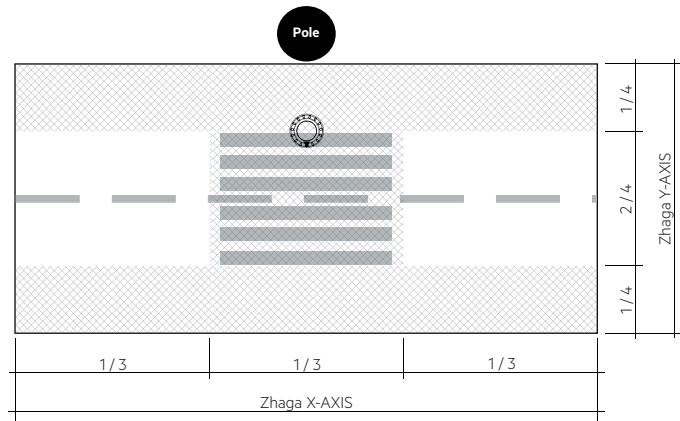
Overview of sensitivity areas:



 The full detection area is rectangular, the highlighted area is optimized for detection of pedestrians. The detection area is not sharp-edged but runs smoothly over the marked borders.

Sensitivity of the sensor can be matched via Application-Controller.

4.2 Motion detection area

The triangular sign indicates the direction to the street (Zhaga y axis) when the sensor is locked in place.

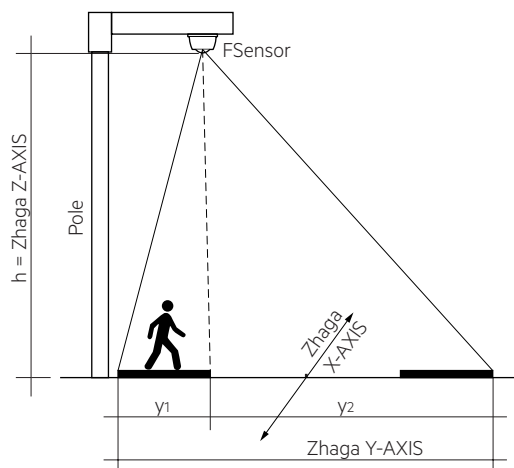

The detection range area y_1 can be reduced if the sensor is mounted too close to the pole.

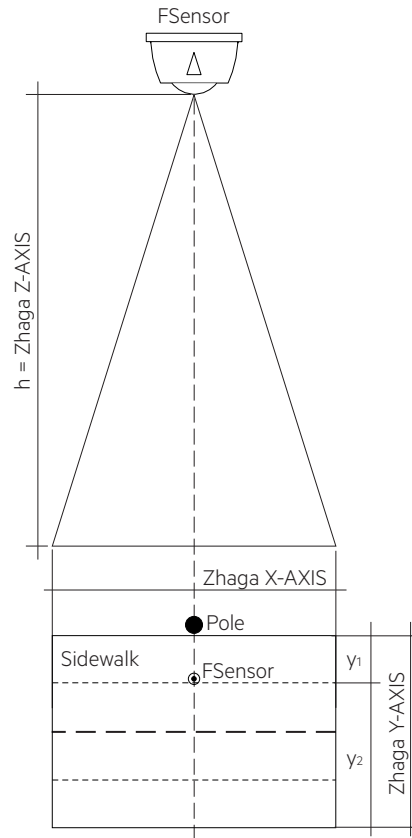

Height	Detection area				Covered area
	x	y	y ₁	y ₂	
4.0 m	17.0 m	8 m	2.0 m	6.0 m	136 m ²
4.5 m	19.3 m	9 m	2.3 m	6.8 m	173 m ²
5.0 m	21.5 m	10 m	2.5 m	7.5 m	215 m ²
5.5 m	23.8 m	11 m	2.8 m	8.3 m	261 m ²
6.0 m	26.0 m	12 m	3.0 m	9.0 m	312 m ²
6.5 m	28.3 m	13 m	3.3 m	9.8 m	367 m ²
7.0 m	30.5 m	14 m	3.5 m	10.5 m	427 m ²
7.5 m	32.8 m	15 m	3.8 m	11.3 m	491 m ²
8.0 m	35.0 m	16 m	4.0 m	12.0 m	560 m ²

4.3 Light measurement

The light measurement is detected in an angle of 76°.

The light sensor is located behind the sensor lens, for that reason, the sensor is not sufficient to be used for constant light control.

The triangular sign indicates the direction to the street (Zhaga y axis) when the sensor is locked in place.

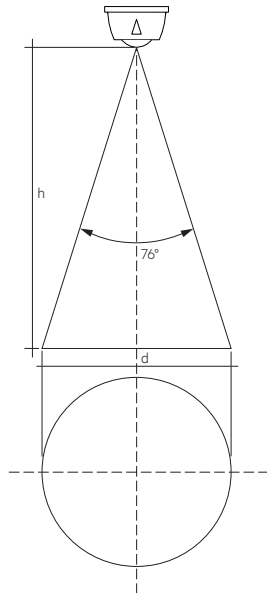

Height	Detection area	Covered area
h	d	-
4.0 m	6.2 m	31 m ²
4.5 m	7.0 m	39 m ²
5.0 m	7.8 m	48 m ²
5.5 m	8.6 m	58 m ²
6.0 m	9.4 m	69 m ²
6.5 m	10.2 m	81 m ²
7.0 m	10.9 m	94 m ²
7.5 m	11.7 m	108 m ²
8.0 m	12.5 m	123 m ²

4.4 Status LED

There is a LED built in to indicate different status information to the user.

Event	Blinking sequence	LED Color
Identify device	500 ms on / 500 ms off for 10 s	Red
Powering the sensor	The LED in the sensor flashes for 5 s with a 500 ms pulse duration to signal the installer that the sensor is ready for use.	Green
Motion detection ^①	Default deactivated but can be activated by the application controller. If active, 1,000 ms on every time Motion is detected.	Red

Light measurement priority

① By default, these blinking patterns are interrupted by the light measurement, because the light measurement has a higher priority. This behavior can be changed via the application controller, i.e. it can be configured that the blinking patterns are carried out, regardless of an ongoing light measurement. Consequently, the accuracy of the light measurement will become worse, because the brightness of the LED distorts the measurement.

5. Miscellaneous

5.1 Disposal of equipment



Return old devices in accordance with the WEEE directive to suitable recycling facilities.

5.2 Additional information

Additional technical information at www.tridonic.com → Technical Data

Guarantee conditions at www.tridonic.com → Services

Lifetime declarations are informative and represent no warranty claim. No warranty if device was opened.

5.3 Additional information

The Bluetooth® word mark and logos are registered trademarks owned by the Bluetooth SIG, Inc. and any use of such marks by Zumtobel Group AG is under license.

Tridonic GmbH & Co. KG is a subsidiary of Zumtobel Group AG.

Wireless Reference Plattform (WRP) is Tridonic's own wireless architecture which is build in this product.

Additional technical information at www.tridonic.com Technical Data

Lifetime declarations are informative and represent no warranty claim. No warranty if device was opened.