

**EM ready2apply SELFTEST 2 W**

EM ready2apply



**Product description**

- \_ LED emergency module suitable for direct installation in ceilings
- \_ Complete set with integrated electronics, LED module, heat sink, optics and battery
- \_ Includes click-in multi-lens option for anti-panic, escape route and spot illumination
- \_ Emergency lighting with self-test function
- \_ Small size ceiling hole, 40 – 43 mm diameter, 80 mm height
- \_ EM = Emergency

**Properties**

- \_ Output power 1.5 W
- \_ Very low stand-by power loss
- \_ White or black housing colour options
- \_ Non-maintained variants
- \_ 1 or 3 h rated duration (separate variants)
- \_ Plug-in Lithium Iron Phosphate battery with strain-relief
- \_ 5 years guarantee electronic (LED driver) (conditions at <https://www.tridonic.com/en/int/services/manufacture-guarantee-conditions>)
- \_ 5 years guarantee for LiFePO4 batteries (conditions at <https://www.tridonic.com/en/int/services/manufacture-guarantee-conditions>)

**Website**

<http://www.tridonic.com/89800538>



**EM ready2apply SELFTEST 2 W**

EM ready2apply

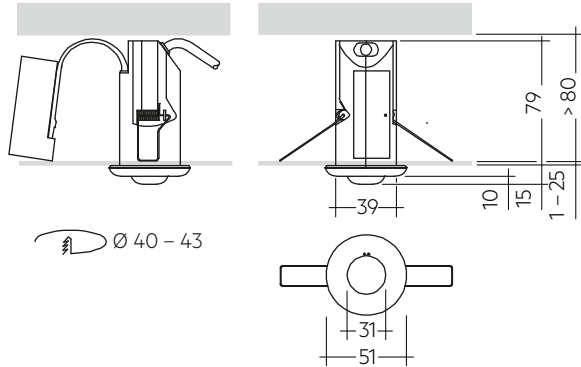

**Ordering data**

Type	Article number	Colour	Operating mode	Rated duration	Number of cells	Packaging, carton	Packaging, pallet	Weight per pc.
EM R2A ST NM 111 2W	89800538	White	Non-maintained	1 h	1	1 pc(s).	380 pc(s).	0.19 kg
EM R2A ST M 111 2W	89800539	White	Maintained	1 h	1	1 pc(s).	380 pc(s).	0.19 kg
EM R2A ST NM 132 2W	89800540	White	Non-maintained	3 h	2	1 pc(s).	380 pc(s).	0.23 kg
EM R2A ST NM 132 2W B	89801052	Black	Non-maintained	3 h	2	1 pc(s).	380 pc(s).	0.23 kg
EM R2A ST M 132 2W	89800541	White	Maintained	3 h	2	1 pc(s).	380 pc(s).	0.23 kg

**Technical data**

Rated supply voltage	220 – 240 V
Input voltage range AC (tolerance for safety)	198 – 264 V
Input voltage range AC (tolerance for performance)	198 – 254 V
Mains frequency	50 / 60 Hz
Overvoltage protection	320 V (for 48 h)
Starting time (Emergency operation)	< 0.5 s from detection of emergency event
THD normal operation (maintained operation, at 230 V, 50 Hz, charging)	75 %
Output current tolerance	+ 5 %
LF current ripple	+ 5 %
Ambient temperature ta	5 ... +30 °C
Mains voltage changeover threshold	According to EN 60598-2-22
Type of protection	IP20
Impact protection degree <sup>①</sup>	IK03
Protection class	II
Colour temperature	6,500 K
Colour tolerance	3 SDCM
Colour rendering index CRI	> 80
Lifetime	up to 50,000 h
EoFI	1

**Approval marks**



**Standards**

according to EN 50172, EN 55015, EN 60068-2-29, EN 60068-2-30, EN 60068-2-64, EN 60598-1, EN 60598-2-2, EN 60598-2-22, EN 61000-3-2, EN 61347-1, EN 61347-2-7, EN 61347-2-13, EN 61547, EN 62034, EN 62384, IEC 62133 (related to Lithium Iron battery), UN 38.3 (related to Lithium Iron battery), EN 62031, EN 62471

Specific technical data

Type	Number of battery cells	Rated duration	Mains current (230 V, 50 Hz), maintained		Mains current (230 V, 50 Hz), non-maintained		Mains power (230 V, 50 Hz), maintained		Mains power (230 V, 50 Hz), non-maintained		Typ. $\lambda$ (at 230 V, 50 Hz, charging)	Typ. output current	Typ. forward voltage	Output power
			Charging	Charger off	Charging	Charger off	Charging	Charger off	Charging	Charger off				
			<b>Normal operation</b>											
EM R2A ST NM 111 2W	1	1 h	-	-	15 mA	10 mA	-	-	1.5 W	0.6 W	0.42C	-	-	-
EM R2A ST M 111 2W	1	1 h	35 mA	26 mA	-	-	4.5 W	3.2 W	-	-	0.58C	126 mA	12 V	1.5 W
EM R2A ST NM 132 2W	2	3 h	-	-	20 mA	10 mA	-	-	2.5 W	0.6 W	0.50C	-	-	-
EM R2A ST M 132 2W	2	3 h	40 mA	26 mA	-	-	5.5 W	3.2 W	-	-	0.58C	126 mA	12 V	1.5 W
EM R2A ST NM 132 2W B	2	3 h	-	-	20 mA	10 mA	-	-	2.5 W	0.6 W	0.50C	-	-	-
<b>Emergency operation</b>														
EM R2A ST NM 111 2W	1	1 h	-	-	-	-	-	-	-	-	-	126 mA	12 V	1.5 W
EM R2A ST M 111 2W	1	1 h	-	-	-	-	-	-	-	-	-	126 mA	12 V	1.5 W
EM R2A ST NM 132 2W	2	3 h	-	-	-	-	-	-	-	-	-	126 mA	12 V	1.5 W
EM R2A ST M 132 2W	2	3 h	-	-	-	-	-	-	-	-	-	126 mA	12 V	1.5 W
EM R2A ST NM 132 2W B	2	3 h	-	-	-	-	-	-	-	-	-	126 mA	12 V	1.5 W

① IK rating valid for lens

LiFePO4 Battery pack 1.5 – 3.0 Ah

Accessory



**Product description**

- \_ Lithium Iron Phosphate replacement battery pack for use with EM ready2apply emergency lighting units
- \_ 8 year design life (up to 30 °C ambient temperature)
- \_ 5 years guarantee (Conditions at <https://www.tridonic.com/en/int/services/manufacturer-guarantee-conditions>)

**Properties**

- \_ Certified quality manufacturer
- \_ Casing material made of polycarbonate
- \_ Charge efficiency > 90 %
- \_ Low self discharge
- \_ Compact connector providing polarity safe battery connection
- \_ Protection and monitoring circuit built into battery enclosure
- \_ Battery protected against operation at excessive temperatures
- \_ Deep discharge protection
- \_ Suitable for emergency lighting equipment as per IEC 60598-2-22

**Website**

<http://www.tridonic.com/89800555>



LiFeGuard

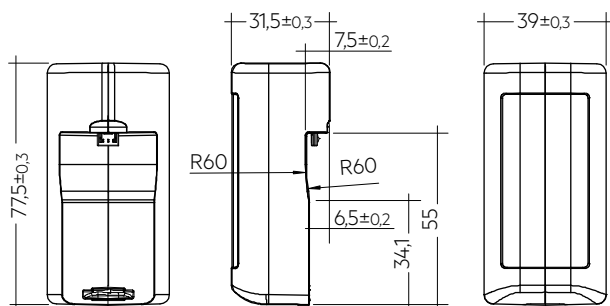

**Ordering data**

Type	Article number	Capacity	Packaging, carton	Weight per pc.
<b>1.5 Ah battery pack</b>				
PACK-LiFePO4 1.5Ah R2A	89800555	1.5 Ah	75 pc(s).	0.064 kg
<b>3.0 Ah battery pack</b>				
PACK-LiFePO4 3.0Ah R2A	89800556	3.0 Ah	75 pc(s).	0.104 kg

Approval marks



## 1. Standards

according to EN 50172  
 EN 55015  
 EN 60068-2-6  
 according to EN 60068-2-30  
 EN 60598-1  
 EN 60598-2-2  
 EN 60598-2-22  
 EN 61000-3-2  
 EN 61347-1  
 EN 61347-2-7  
 EN 61347-2-13  
 EN 61547  
 EN 62034  
 EN 62384  
 IEC 62133 (related to Lithium Iron battery)  
 UN 38.3 (related to Lithium Iron battery)  
 EN 62031  
 EN 62471

### 1.1 Glow-wire test

according to EN 60598-1 with increased temperature of 850 °C passed.

## 2. Thermal data

### 2.1 Temperature range

According to the standard IEC 60598-1 a LED Driver for remote installation has a max. case temperature of 90 °C. The ambient temperature range  $t_a$  for the EM R2A ST is defined to meet this requirement.

### 2.2 Expected lifetime

#### 2.2.1 Electronics

Average lifetime 50,000 hours under rated conditions with a failure rate of less than 10 %. Average failure rate of 0.2% per 1000 operating hours.

#### Expected lifetime

Type	$t_a$	25 °C	30 °C	40 °C
EM R2A ST	lifetime	> 50,000 h	50,000 h	50,000 h

## 2.3 Storage conditions

- Humidity 45% up to max. 85%, not condensed (max. 56 days/year at 85 %)
- Storage time / temperature: max. 6 months at -20 °C up to +45 °C (< 3 months at +45 °C)

Note: The devices have to be within the specified temperature range ( $t_a$ ) before they are operated.

- Store batteries within the specified temperature range in low humidity conditions. Optimal storage conditions are:
  - Temperature: -20... +35 °C for up to 15 months
  - Relative humidity: 65% ±5%
- Avoid atmosphere with corrosive gas
- Disconnect batteries before store or delivery
- Avoid storage of discharged batteries

## 3. Installation / Wiring

### 3.1 Lens assembly

- Wear gloves when mounting the lens
- Take care of the mounting direction of the escape route lens
- Use screwdriver for replacing/removing lens
  - + 2. Push lens clips with screwdriver via openings on both sides
  3. Remove lens

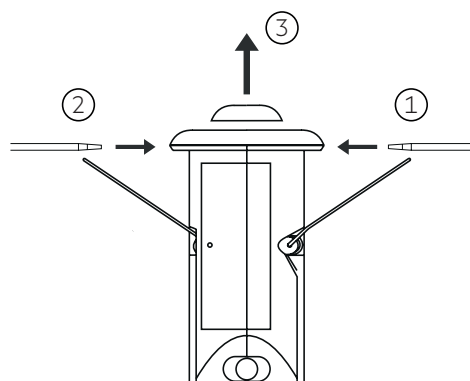

3.2 Wiring diagrams

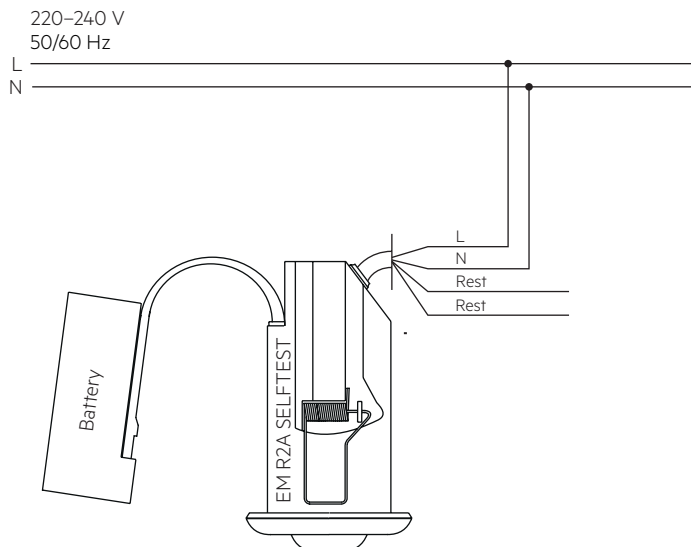

Note: Battery must be connected before mains connection.

3.3 Wiring type and cross-section

Wiring

Mains (N, L): brown, blue  
Rest: orange, orange

Cable length: 250mm with strain relief at the R2A ST module  
Cable: low smoke, halogen free

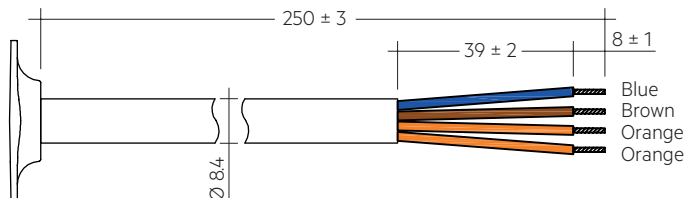
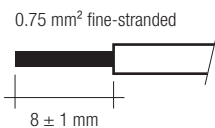

Recommended connector with strain-relief (plug and socket):  
Wieland GST18

No terminal block included. The installation of the terminal block has to be done by a qualified person.

Only a terminal complying with EN 60998-2-1 or EN 60998-2-2 shall be used

Note: If mains cable or battery strap are damaged the luminaire must be disposed.

5. Electrical data

5.1 Maximum loading of automatic circuit breakers

Automatic circuit breaker type	C10	C13	C16	C20	B10	B13	B16	B20	Inrush current
Installation Ø	1.5 mm <sup>2</sup>	1.5 mm <sup>2</sup>	2.5 mm <sup>2</sup>	4 mm <sup>2</sup>	1.5 mm <sup>2</sup>	1.5 mm <sup>2</sup>	2.5 mm <sup>2</sup>	4 mm <sup>2</sup>	I <sub>max</sub> time
<b>EM R2A ST</b>	180	260	260	260	90	130	130	130	10 A 120 µs

5.2 Harmonic distortion in the mains supply (at 230 V / 50 Hz and 2-cell maintained charging) in %

	THD	3.	5.	7.	9.	11.
<b>EM R2A ST</b>	< 75	< 62	< 33	< 19	< 18	< 13

4. Mechanical data

4.1 Housing properties

- Polycarbonate white RAL 9016
- Polycarbonate black RAL 9005

4.2 Battery connection

Battery pack end termination  
Compact micro USB type B connector providing safe battery connection

- Module end termination
- Battery strap with compact micro USB type B connector
  - Strain relief at the module casing and locking clip for secure connection of the battery pack
  - Battery strap: low smoke, halogen free

Note: Strap not suitable for connection of any other micro USB device other than the ready2apply battery pack

4.3 Fixing

Spring fixing through hole in ceiling

- Hole diameter: 40 – 43 mm
- Ceiling thickness: 1 – 25 mm
- Ceiling void height: > 80 mm



Device not suitable for covering with thermally insulating material

### 5.3 Insulation matrix

	Mains	Battery	Rest
Mains	–	• •	•
Battery	• •	–	•
Rest	•	•	–

- Represents basic insulation
- • Represents double or reinforced insulation

### 5.4 Battery charge regime / discharge

#### EM R2A ST 2 W, 1 / 3 h

	Type	EM R2A ST 2 W	EM R2A ST 2 W
	Article no.		89800538
Cells		1 cells	2 cells
Duration		1 h	3 h
Battery charge time	Initial	20 h	
	Recharge	12 h	
	Trickle charge	continuously and battery voltage controlled	
Typ. charge current <sup>®</sup>	Initial charge	140 mA	290 mA
	Recharge	140 mA	290 mA
	Trickle charge	140 mA / 0 mA	290 mA / 0 mA
Mains power consumption	Initial charge	< 1.095 W	< 1.095 W
	Recharge	< 1.095 W	< 1.095 W
	Trickle charge	< 1.095 W / 0 W	< 1.095 W / 0 W
Discharge current at 3.2 V (nominal)		625 mA	625 mA

<sup>®</sup> Automatic recharge when battery voltage falls below 3.4 V. Charger off (0 mA) when battery voltage exceeds 3.6 V.

Note: Battery protected against operation at excessive temperatures (charging stopped when battery cell temperature < 0 °C or > 60 °C)

### 5.5 Battery selection for replacement

#### EM R2A ST 2 W, 1 / 3 h

		Type	EM R2A ST 2 W	EM R2A ST 2 W	
		Article no.	89800538	89800540, 89801052	
		Cells	1 cells	2 cells	
		Duration	1 h	3 h	
Technology and capacity	Design	Number of cells	Type	Article no.	Assignable batteries
Lithium Iron Phosphate 1.5 Ah	single cell	1	PACK-LiFePO4 1,5Ah R2A	89800555	•
Lithium Iron Phosphate 3 Ah	side by side	1 + 1	PACK-LiFePO4 3,0Ah R2A	89800556	•

Note: If the rated duration of operation cannot be reached the battery must be replaced. Remove mains during battery replacement.

## 6. Functions

### 6.1 Status indication

System status is indicated by a bi-colour LED. The indication LED is integrated in the bezel.

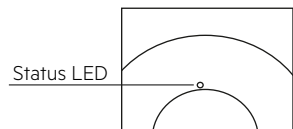

LED indication	Status	Comment
Permanent green	System OK	AC mode
Fast flashing green (0,1 sec on – 0,1 sec off)	Function test underway	
Slow flashing green (1 sec on – 1 sec off)	Duration test underway	
Red LED on	Load failure	Open circuit / Short circuit / LED failure
Slow flashing red (1 sec on – 1 sec off)	Battery failure	Battery failed the duration test or function test / Battery is defect or deep discharged / Incorrect battery voltage / Battery is outside of its temperature range for charging (0 – 60 °C)
Fast flashing red (0,1 sec on – 0,1 sec off)	Charging failure	Incorrect charging current
Double pulsing green	Inhibit mode	Switching into inhibit mode via controller
Green and red off	DC mode	Battery operation (emergency mode)

### 6.2 Testing

Emergency operation can be manually tested by removal of the mains supply.

#### Commissioning test

A full commissioning test is carried out automatically after permanent connection of the supply for 5 days. The easy commissioning feature will set the initial test day and time to ensure random testing of units.

#### Functional test

Functional tests are carried out for 5 seconds on a weekly basis under the control of the Micro controller. Initiation and timing of these tests is set during the commissioning of the luminaire.

#### Duration test

A full duration test is carried out yearly to check the capacity of the batteries.

For a full description of commissioning and test features please refer to application notes.

#### Timer reset functionality

The timer for function and duration test can be set to a particular time of the day by cycling the unswitched line supply 5 times within 1 minute. The timer adjustment will enable the test start time to be defined manually at time in day when the timer was reset. It will also disable the adaptive test algorithm thereby forcing the unit to perform the test at the same time rather than it being defined by the adaptive algorithm. This function will only work provided the interval time is greater than zero (automatic test mode enabled). The delay timer value set when the unit was commissioned will be reloaded in order to randomise the tests between adjacent units.

### Rest mode

Rest mode can be initiated by applying a short pulse of between 9.5 V<sub>DC</sub> and 22.5 V<sub>DC</sub> in amplitude for a period of between 150 ms and 1.0 s. This should be applied to terminals marked Rest after the mains supply has been disconnected and whilst the module is in emergency operation. Terminals are not sensitive to polarity.

After a mains reset the EM R2A ST exits the rest mode. The EM R2A ST supports the re-light function.

Pulse/Mode	Standby	Emergency	Rest
150 – 1,000 ms	Inhibit	Rest	–
1,001 – 2,000 ms	Cancel inhibit	–	re-light

### 6.3 Technical data batteries

#### Accu Lithium Iron Phosphate

Case temperature range to ensure 8 years design life	1.5 / 3.0 Ah, insulated ceilings	+5 °C to +35 °C
Case temperature range to ensure 6 years design life	1.5 / 3.0 Ah, non-insulated ceilings	+5 °C to +45 °C
International designation		IFpR 19/66
Battery voltage/cell		3.2 V
Single cell dimensions		
Diameter		18 mm
Height		65 mm
Capacity one cell		1.5 Ah
Capacity two cell pack		3.0 Ah
Max. short term temperature (reduced lifetime)		55 °C
Max. number discharge cycles		50 cycles total
Packing quantity		1 pc. per carton

Comply with UN 38.3 and IEC 62133 (safety testing) protected against over charge, over discharge, charging at excessive temperatures, short-circuit and over current.

For battery data see separate data sheet.

## 7. Optical properties

### 7.1 Anti panic

#### Max. spacing for >0.5 lux<sup>®</sup>

Height	Centre to end <sup>®</sup>		Centre to centre <sup>®</sup>	
	Trans	Axial	Trans	Axial
2.5 m	3.85 m	3.80 m	10.90 m	10.85 m
3.0 m	3.80 m	3.75 m	11.90 m	11.90 m
3.5 m	3.80 m	3.80 m	12.90 m	12.90 m
4.0 m	3.70 m	3.70 m	13.90 m	13.85 m
5.0 m	3.55 m	3.50 m	14.90 m	14.90 m
6.0 m	3.10 m	3.05 m	15.10 m	15.05 m

All values for  $t_a = 30^\circ\text{C}$

Luminous flux: 200 lm

<sup>®</sup> Maintenance factor = 0.8, photometric data available on request

<sup>®</sup> Distance between module and wall

<sup>®</sup> Distance between two modules

#### Light distribution

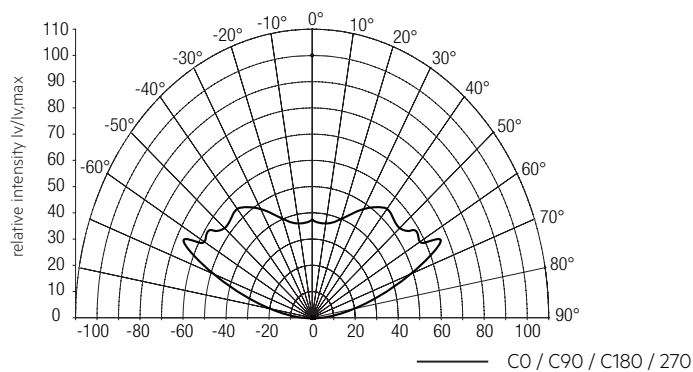

### 7.2 Escape route

#### Max. spacing for >1.0 lux<sup>®</sup>

Height	Centre to end <sup>®</sup>		Centre to centre <sup>®</sup>	
	Trans	Axial	Trans	Axial
2.5 m	4.75 m	2.75 m	11.65 m	6.55 m
3.0 m	4.80 m	2.95 m	12.75 m	7.20 m
3.5 m	5.05 m	1.50 m	13.45 m	6.85 m
4.0 m	5.20 m	1.65 m	13.60 m	6.50 m
5.0 m	5.50 m	1.80 m	14.30 m	4.35 m
6.0 m	5.70 m	1.90 m	15.05 m	4.85 m
7.0 m	5.75 m	1.90 m	15.60 m	5.15 m
8.0 m	5.65 m	1.85 m	16.05 m	5.35 m

All values for  $t_a = 30^\circ\text{C}$

Luminous flux: 200 lm

<sup>®</sup> Maintenance factor = 0.8, photometric data available on request

<sup>®</sup> Distance between module and wall

<sup>®</sup> Distance between two modules

#### Light distribution

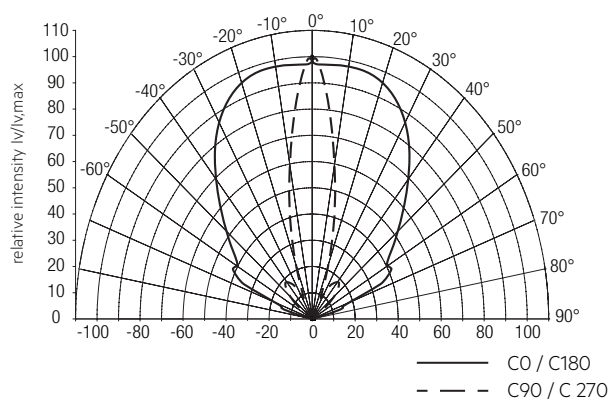

### 7.3 Spot

#### Max. spacing for >0.5 lux / > 5 lux<sup>®</sup>

Minimum illuminance	Height	Centre to end <sup>®</sup>		Centre to centre <sup>®</sup>	
		Trans	Axial	Trans	Axial
0.5	2.5 m	1.05 m	1.90 m	8.40 m	4.30 m
	3.0 m	2.35 m	1.25 m	5.35 m	5.20 m
	3.5 m	2.80 m	1.45 m	6.25 m	6.05 m
	4.0 m	1.70 m	1.70 m	7.90 m	5.85 m
	5.0 m	2.10 m	2.05 m	8.90 m	8.40 m
	6.0 m	2.30 m	2.30 m	8.15 m	8.10 m
	7.0 m	2.50 m	2.45 m	8.00 m	8.00 m
	8.0 m	2.65 m	2.60 m	7.80 m	7.85 m
5.0	2.5 m	0.85 m	0.80 m	2.50 m	2.45 m
	3.0 m	0.90 m	0.85 m	2.55 m	2.55 m
	3.5 m	0.90 m	0.90 m	2.75 m	2.75 m
	4.0 m	0.90 m	0.95 m	2.95 m	2.95 m
	5.0 m	0.95 m	0.90 m	3.30 m	3.25 m
	6.0 m	0.95 m	0.90 m	3.50 m	3.45 m
	7.0 m	0.85 m	0.85 m	3.60 m	3.55 m
	8.0 m	0.75 m	0.75 m	3.60 m	3.60 m

All values for  $t_a = 30^\circ\text{C}$

Luminous flux: 200 lm

<sup>®</sup> Maintenance factor = 0.8, photometric data available on request

<sup>®</sup> Distance between module and wall

<sup>®</sup> Distance between two modules

#### Light distribution

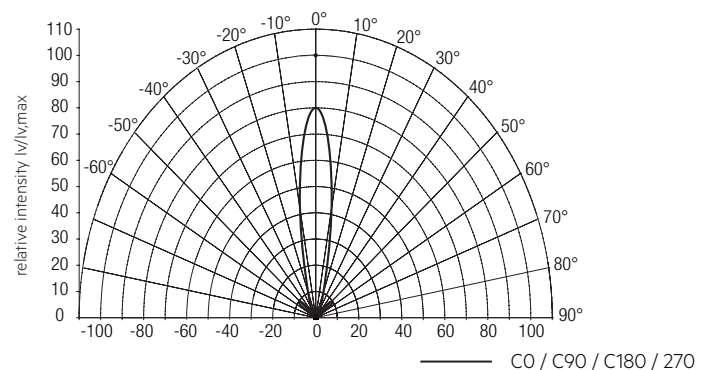

## 8. Miscellaneous

### 8.1 Black Box data recording

Recording of several parameters only accessible for Tridonic.

### 8.2 Additional information

Additional technical information at [www.tridonic.com](http://www.tridonic.com) → Technical Data

The light source of this luminaire is not replaceable; when the light source reaches its end of life replace the whole luminaire. Lifetime declarations are informative and represent no warranty claim. No warranty if device was opened.