

EM ready2apply PRO 2 – 3 W

EM ready2apply



Product description

- _ LED emergency module suitable for direct installation in ceilings
- _ Complete set with integrated electronics, LED module, optics and battery
- _ All components replaceable on site (Battery, LED module, LED driver, lenses, etc.)
- _ DALI interface and automatic test function
- _ Small size ceiling hole, 68 – 72 mm diameter, 100 mm height
- _ IP65 protection rating (in installed state)
- _ EM = Emergency

Properties

- _ Output power 2 – 3 W
- _ Very low stand-by power loss
- _ Replaceable bezel, black as an option
- _ Non-maintained variants
- _ 3 h rated duration
- _ Plug-in Lithium Iron Phosphate battery
- _ 5 years guarantee electronic (LED driver) (conditions at <https://www.tridonic.com/en/int/services/manufacture-guarantee-conditions>)
- _ 5 years guarantee for LiFePO4 batteries (conditions at <https://www.tridonic.com/en/int/services/manufacture-guarantee-conditions>)

Website

<http://www.tridonic.com/89801224>



EM ready2apply PRO 2 – 3 W

EM ready2apply

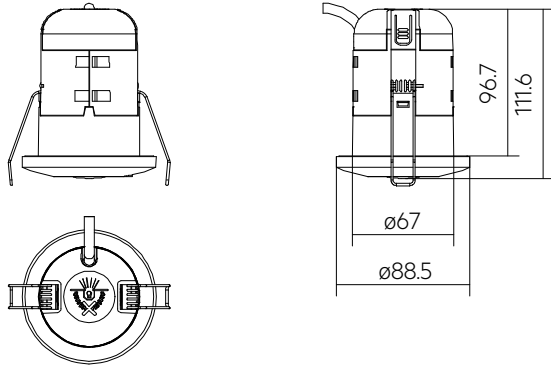

Ordering data

Type	Article number	Operating mode	Rated duration	Number of cells	Packaging, carton	Packaging, pallet	Weight per pc.
EM R2A 68mm PRO NM 132 AP	89801224	Non-maintained	3 h	1	1 pc(s).	180 pc(s).	0.375 kg
EM R2A 68mm PRO NM 133 AP	89801230	Non-maintained	3 h	3	1 pc(s).	180 pc(s).	0.415 kg
EM R2A 68mm PRO NM 132 ER	89801225	Non-maintained	3 h	1	1 pc(s).	180 pc(s).	0.375 kg
EM R2A 68mm PRO NM 133 ER	89801231	Non-maintained	3 h	3	1 pc(s).	180 pc(s).	0.415 kg

Technical data

Rated supply voltage	220 – 240 V
Input voltage range AC (tolerance for safety)	198 – 264 V
Input voltage range AC (tolerance for performance)	198 – 254 V
Mains frequency	50 / 60 Hz
Overvoltage protection	320 V (for 48 h)
Starting time (Emergency operation)	< 0.5 s from detection of emergency event
Output current tolerance	± 5 %
LF current ripple	± 5 %
Ambient temperature t_a	5 ... +40 °C
Mains voltage changeover threshold	According to EN 60598-2-22
Type of protection	IP20
Impact protection degree	IK03
Protection class	II
Colour temperature	6,500 K
Colour tolerance	3 SDCM
Colour rendering index CRI	> 80
Lifetime	up to 50,000 h
EoFI	1

Approval marks



Standards

according to EN 50172, EN 55015, EN 60068-2-6, EN 60068-2-30, EN 60598-1, EN 60598-2-2, EN 60598-2-22, EN 61000-3-2, EN 61000-3-3, EN 61347-1, EN 61347-2-7, EN 61347-2-13, EN 61547, acc. to EN 62034, EN 62384, EN 62386-101, EN 62386-102, EN 62386-202, IEC 62133 (related to Lithium Iron battery), UN 38.3 (related to Lithium Iron battery), EN 62031, EN 62471

Specific technical data

Type	Number of battery cells	Rated duration	Mains current (230 V, 50 Hz), non-maintained		Typ. λ (at 230 V, 50 Hz, charging)	Typ. output current	Typ. forward voltage	Output power
			Charging	Charger off				
Normal operation								
EM R2A 68mm PRO NM 132 AP	1	3 h	15 mA	5 mA	0.66C	-	-	-
EM R2A 68mm PRO NM 132 ER	1	3 h	15 mA	5 mA	0.66C	-	-	-
EM R2A 68mm PRO NM 133 AP	3	3 h	15 mA	5 mA	0.66C	-	-	-
EM R2A 68mm PRO NM 133 ER	3	3 h	15 mA	5 mA	0.66C	-	-	-
Emergency operation								
EM R2A 68mm PRO NM 132 AP	1	3 h	-	-	-	170 mA	12 V	2.0 W
EM R2A 68mm PRO NM 132 ER	1	3 h	-	-	-	170 mA	12 V	2.0 W
EM R2A 68mm PRO NM 133 AP	3	3 h	-	-	-	225 mA	12 V	2.6 W
EM R2A 68mm PRO NM 133 ER	3	3 h	-	-	-	225 mA	12 V	2.6 W

LiFePO4 Battery pack 3.3 – 4.8 Ah

Accessory



ACCU-LiFePO4 4.8Ah 3B CON R2A 68MM

Product description

- _ High-temperature LiFePO4 cells only for use with Tridonic emergency lighting units
- _ 6 year design life (up to 30 °C ambient temperature)
- _ 4 year design life (up to 40 °C ambient temperature)
- _ 5 years guarantee (conditions at <https://www.tridonic.com/en/int/services/manufacturer-guarantee-conditions>)

Properties

- _ Certified quality manufacturer
- _ Charge efficiency > 90 %
- _ Low self discharge
- _ Simple connection with plug-in system
- _ Protection and monitoring circuit built into battery enclosure
- _ Deep discharge protection
- _ Suitable for emergency lighting equipment as per IEC 60598-2-22

Website

<http://www.tridonic.com/28005687>

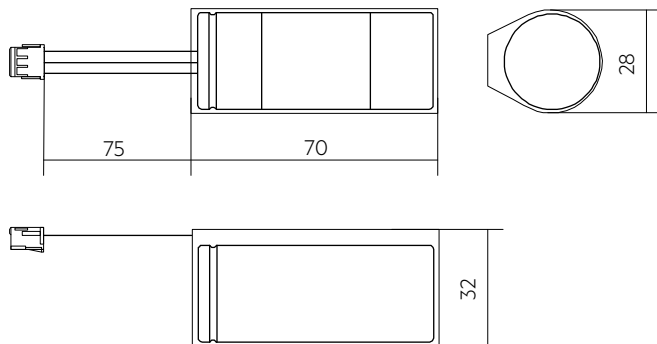

ACCU-LiFePO4 3.3Ah 1A CON R2A 68MM

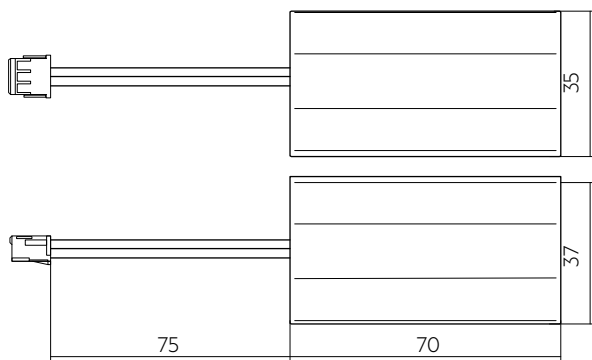

ACCU-LiFePO4 4.8Ah 3B CON R2A 68MM

Ordering data

Type	Article number	Capacity	Packaging, carton	Packaging, outer box	Weight per pc.
ACCU-LiFePO4 4.8Ah 3B CON R2A 68MM	28005687	4.8 Ah	25 pc(s).	50 pc(s).	0.125 kg
ACCU-LiFePO4 3.3Ah 1A CON R2A 68MM	28005688	3.3 Ah	20 pc(s).	80 pc(s).	0.232 kg

EM r2a 68mm Bezel

Accessory



Product description

- _ Replaceable bezel
- _ Suitable for the use with EM r2a 68mm
- _ Black (RAL 9005)
- _ Polycarbonate

Website

<http://www.tridonic.com/28006212>



Ordering data

Type	Article number	Colour	Packaging, carton	Weight per pc.
EM r2a 68mm B	28006212	Black	100 pc(s).	0.091 kg

1. Standards

according to EN 50172
 EN 55015
 EN 60068-2-6
 according to EN 60068-2-30
 EN 60598-1
 EN 60598-2-2
 EN 60598-2-22
 EN 61000-3-2
 EN 61000-3-3
 EN 61347-1
 EN 61347-2-7
 EN 61347-2-7/A1
 EN 61347-2-13
 EN 61347-2-13/A1
 EN 61547
 according to EN 62034
 EN 62384
 EN 62386-101
 EN 62386-102
 EN 62386-202
 IEC 62133 (related to Lithium Iron battery)
 UN 38.3 (related to Lithium Iron battery)
 EN 62031
 EN 62471

1.1 Glow-wire test

according to EN 60598-1 with increased temperature of 850 °C passed.

2. Thermal data

2.1 Temperature range

According to the standard IEC 60598-1 a LED Driver for remote installation has a max. case temperature of 90 °C. The ambient temperature range t_a for the EM R2A PRO is defined to meet this requirement.

2.2 Expected lifetime

Average lifetime 50,000 hours under rated conditions with a failure rate of less than 10 %. Average failure rate of 0.2 % per 1000 operating hours.

Expected lifetime

Type	t_a	25 °C	35 °C	40 °C
EM R2A PRO	lifetime	> 100,000 h	> 100,000 h	> 100,000 h

2.3 Storage conditions

- Humidity 5% up to max. 85 %, not condensed (max. 56 days/year at 85 %)

Note: The devices have to be within the specified temperature range (t_a) before they are operated.

- Store batteries within the specified temperature range in low humidity conditions. Optimal storage conditions are:
 - Temperature: -20...+35 °C for up to 15 months
 - Relative humidity: 65 % ±5 %
- Avoid atmosphere with corrosive gas
- Disconnect batteries before store or delivery
- Avoid storage of discharged batteries

3. Installation / Wiring

3.1 Wiring diagram

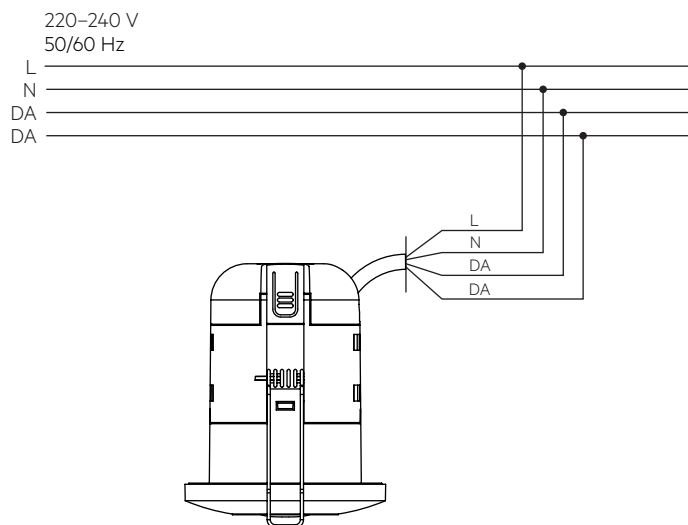

Note: Battery must be connected before mains connection.

3.2 Wiring type and cross-section

Wiring

Mains (L, N): brown, blue
 DALI (DA, DA): orange, orange

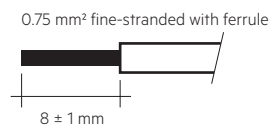

Cable length: 250 mm with strain relief at the R2A PRO module
 Cable: low smoke, halogen free

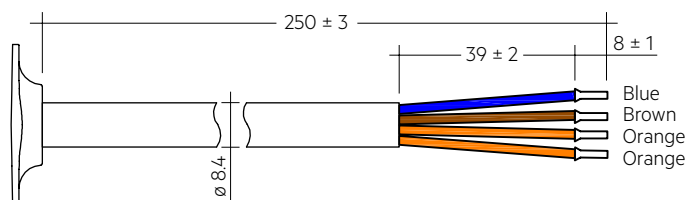

Recommended connector with strain-relief (plug and socket):
 Wieland GST18

No terminal block included. The installation of the terminal block has to be done by a qualified person.

Only a terminal complying with EN 60998-2-1 or EN 60998-2-2 shall be used

Note: If mains cable or battery strap are damaged the luminaire must be disposed.

4. Mechanical data

4.1 Housing properties

- Polycarbonate white RAL 9016
- Polycarbonate black RAL 9005
- Polycarbonate blue, RAL 5002

4.2 Battery connection

Battery pack connection
Simple connection with plug-in system (polarity reversal protection)

Module connection
Insert the battery in the designated position in the luminaire, plug the connector into the EM ready2apply and attach the safety cap.

4.3 Fixing

Spring fixing through hole in ceiling

- Hole diameter: 68 – 72 mm
- Ceiling thickness: 1 – 25 mm
- Ceiling void height: > 100 mm



Device not suitable for covering with thermally insulating material

5. Electrical data

5.1 Maximum loading of automatic circuit breakers

Automatic circuit breaker type	C10	C13	C16	C20	B10	B13	B16	B20	Inrush current	
									I_{max}	time
EM R2A PRO	180	260	260	260	90	130	130	130	10 A	120 µs

5.2 Insulation matrix

	Mains	Battery	DALI
Mains	–	• •	•
Battery	• •	–	•
DALI	•	•	–

- Represents basic insulation
- • Represents double or reinforced insulation



DALI terminals are not SELV. Wire the terminals in accordance with the requirements of low voltage installations.

5.3 Battery charge regime / discharge

EM R2A 68mm PRO 2 – 3 W, 3 h

Type		EM R2A 68mm PRO 2 W	EM R2A 68mm PRO 3 W
Article no.		89801224, 89801225	89801230, 89801231
Cells		1 cell	3 cells
Duration		3 h	3 h
Battery charge time	Initial	24 h	
	Recharge	24 h	
	Trickle charge	continuously and battery voltage controlled	
Typ. charge current [®]	Initial charge	270 mA	270 mA
	Recharge	270 mA	270 mA
	Trickle charge	270 mA / 0 mA	270 mA / 0 mA
Mains power consumption	Initial charge	2.3 W	2.3 W
	Recharge	2.3 W	2.3 W
	Trickle charge	2.3 W / 0 W	2.3 W / 0 W
Discharge current at 3.2 V (nominal)		715 mA	970 mA

[®] Automatic recharge when battery voltage falls below 3.4 V.
Charger off (0 mA) when battery voltage exceeds 3.6 V.

Note: Battery protected against operation at excessive temperatures
(charging stopped when battery cell temperature < 0 °C or > 60 °C)

5.4 Battery selection for replacement

EM R2A 68mm PRO 2 – 3 W, 3 h

				Type	EM R2A 68mm PRO 2 W	EM R2A 68mm PRO 3 W
				Article no.	89801224, 89801225	89801230, 89801231
				Cells	1 cell	3 cells
				Duration	3 h	3 h
Technology and capacity	Design	Number of cells	Type	Article no.	Assignable batteries	
Lithium Iron Phosphate 3.3 Ah	single cell	1	ACCU-LiFePO4 3.3Ah 1A CON R2A 68MM	28005688	•	
Lithium Iron Phosphate 4.8 Ah	pyramid	3	ACCU-LiFePO4 4.8Ah 3B CON R2A 68MM	28005687		•

Note: If the rated duration of operation cannot be reached the battery must be replaced. Remove mains during battery replacement.

6. Interfaces / communication

6.1 Control input (DALI DT1)

The control input is non-polar for digital control signals (DALI). The control signal is not SELV. Control cable has to be installed in accordance to the requirements of low voltage installations.

7. Functions

7.1 Status indication

System status is indicated by a bi-colour LED and by a DALI status flag. The indication LED is integrated in the bezel.

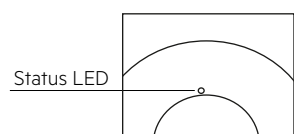

LED indication	Status	Comment
Permanent green	System OK	AC mode
Fast flashing green (0,1 sec on – 0,1 sec off)	Function test underway	
Slow flashing green (1 sec on – 1 sec off)	Duration test underway	
Red LED on	Load failure	Open circuit / Short circuit / LED failure
Slow flashing red (1 sec on – 1 sec off)	Battery failure	Battery failed the duration test or function test / Battery is defect or deep discharged / Incorrect battery voltage / Battery is outside of its temperature range for charging (0 – 60 °C)
Fast flashing red (0,1 sec on – 0,1 sec off)	Charging failure	Incorrect charging current
Double pulsing green	DALI Inhibit	Switching into DALI inhibit mode via controller
Binary transmission of address via green/red LED	Address identification	During address identification mode
Green and red off	DC mode	Battery operation (emergency mode)

7.2 Testing

Emergency operation can be manually tested by removal of the mains supply.

DALI Control

A DALI command from a suitable control unit can be used to initiate function and duration tests at individually selected times. Status flags are set for report back and data logging of results.

When a DALI bus has not been connected or when a DALI bus is connected but the DALI default DELAY and INTERVAL times have not been re-set by sending appropriate DALI commands, then the EM R2A PRO will conduct self-tests in accordance with the default times set within the EEPROM.

These default times are factory pre-set, in accordance with the DALI standard EN 62386-202, to conduct an automatic function test every 7 days and a duration test every 52 weeks. Since the DELAY time is factory pre-set to Zero, all units are tested at the same time. Test times can be changed with a command over the DALI bus.

The DELAY and INTERVAL time values must be re-set when the emergency system test times are to be scheduled by a DALI control and monitoring system.

Note that once the default values have been set to Zero, tests will only be conducted following a command from the control system. If the DALI bus is disconnected the EM R2A PRO does not revert to self-testing mode.

Note: If the battery is connected the DALI communication is only possible after power reset.

Addressing

The EM R2A PRO includes the EZ easy addressing system which allows addressing and identification by using the bi-colour LED. Binary address codes given by the LED can be simply converted to the DALI addresses 0 to 63. For single handed addressing using this method it is necessary to send a broadcast ident command every 3 to 9 seconds. During this command the LEDs will be switched off and the indication LED will flash the 6 bit binary address preceded by a 3 second start indication period.

Commissioning

After installation of the luminaire and initial connection of the mains supply and battery supply to the EM R2A PRO the unit will commence charging the batteries for 24 hours (initial charge). Afterwards the module will conduct a commissioning test for the full duration. The 24 hours recharge occurs also if a new battery is connected or the module exits the rest mode condition. The following automatic commissioning duration test is only performed when a battery is replaced and fully charged (after 24 hrs) and the interval time is not set to zero, otherwise the system is expected to perform the testing.

Functional test

The time of day and frequency of the 5 seconds function test can be set by the DALI controller. The default setting is a 5 seconds test on a weekly basis.

Duration test

The time of day and frequency of the duration test can be set by the DALI controller. The default setting is a duration test conducted every 52 weeks.

Timer reset functionality

The timer for function and duration test can be set to a particular time of the day by cycling the unswitched line supply 5 times within 1 minute. The timer adjustment will enable the test start time to be defined manually at time in day when the timer was reset. It will also disable the adaptive test algorithm thereby forcing the unit to perform the test at the same time rather than it being defined by the adaptive algorithm. This function will only work provided the interval time is greater than zero (automatic test mode enabled). The delay timer value set when the unit was commissioned will be reloaded in order to randomise the tests between adjacent units.

Prolong time

Prolong time can be set by the DALI controller. This is the delay time between return of the mains supply and the end of the emergency operation. The default prolong time is set as 0 minutes as specified within the DALI standard.

Indicator LED will stay off for the duration of the prolong time.

Rest Mode

Rest mode can be initiated by the DALI controller. The appropriate command should be sent after the mains supply has been disconnected and whilst the module is in emergency operation. After a mains reset the EM R2A PRO exits the rest mode. EM R2A PRO supports the re-light command via the DALI bus.

Max. rest mode duration: 21 days from fully charged battery

DALI Controller

DALI controllers and hardware/software solutions are available from Tridonic. Please refer to the Lighting controls section.

7.3 Technical data batteries

Accu Lithium Iron Phosphate

Capacity 3.3 Ah

International designation IFPr 27/67
 Battery voltage/cell 3.2 V
 Cell type 26650
 Single cell dimensions
 Diameter 26 mm
 Height 65 mm
 Max. short term temperature (reduced lifetime) 70 °C
 Max. number discharge cycles 50 cycles total
 Max. storage time 15 months
 at -20 °C to +25 °C
 Packing quantity 1 pc. per carton

Capacity 4.8 Ah

International designation IFPr 19/66
 Battery voltage/cell 3.2 V
 Cell type 18650
 Single cell dimensions
 Diameter 18 mm
 Height 65 mm
 Max. short term temperature (reduced lifetime) 70 °C
 Max. number discharge cycles 50 cycles total
 Max. storage time 15 months
 at -20 °C to +25 °C
 Packing quantity 1 pc. per carton

Only use Tridonic batteries.

Comply with UN 38.3 and IEC 62133 (safety testing) protected against over charge, over discharge, charging at excessive temperatures, short-circuit and over current.

For battery data see separate data sheet.

8. Optical properties

8.1 Anti panic

EM R2A PRO 2W – Max. spacing for >0.5 lux[®]

Height	Centre to end [®]		Centre to centre [®]	
	Trans	Longitudinal	Trans	Longitudinal
2.5 m	4.25 m	4.20 m	11.55 m	11.55 m
3.0 m	4.65 m	4.60 m	12.80 m	12.75 m
4.0 m	4.55 m	4.55 m	14.90 m	14.90 m
5.0 m	4.35 m	4.30 m	16.80 m	16.80 m
6.0 m	4.05 m	4.00 m	17.95 m	17.90 m
8.0 m	-	-	18.15 m	18.10 m
10.0 m	-	-	15.80 m	15.80 m
12.0 m	-	-	12.20 m	12.20 m

Luminous flux: 264 lm.

[®] Maintenance factor = 0.9, photometric data available on request.

[®] Distance between module and wall.

[®] Distance between two modules.

Light distribution

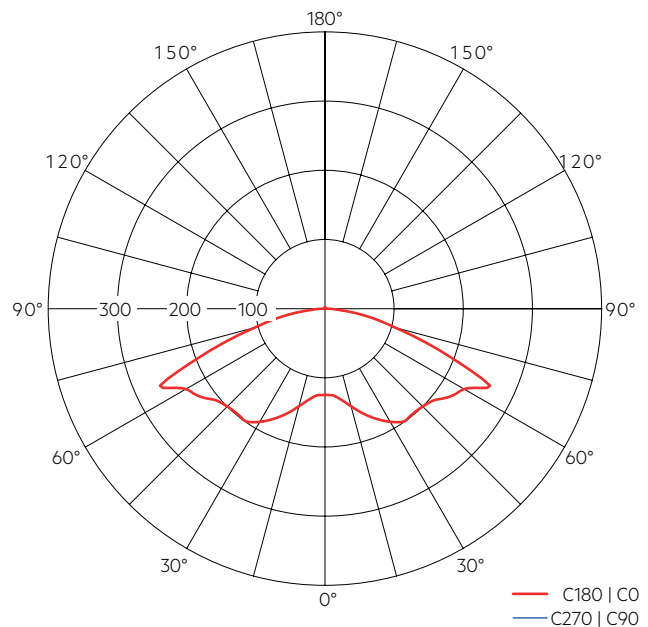

EM R2A PRO 3W – Max. spacing for >0.5 lux^①

Height	Centre to end ^②		Centre to centre ^③	
	Trans	Longitudinal	Trans	Longitudinal
2.5 m	3.10 m	3.05 m	7.10 m	7.08 m
3.0 m	3.55 m	3.50 m	8.20 m	8.20 m
4.0 m	4.40 m	4.35 m	10.30 m	10.25 m
5.0 m	5.10 m	5.05 m	12.20 m	12.20 m
6.0 m	5.20 m	5.15 m	14.05 m	14.00 m
8.0 m	4.75 m	4.70 m	17.40 m	17.40 m
10.0 m	5.00 m	4.95 m	18.30 m	18.30 m
12.0 m	5.05 m	5.05 m	19.55 m	19.55 m

Luminous flux: 308 lm.

^① Maintenance factor = 0,9, photometric data available on request.

^② Distance between module and wall.

^③ Distance between two modules.

Light distribution

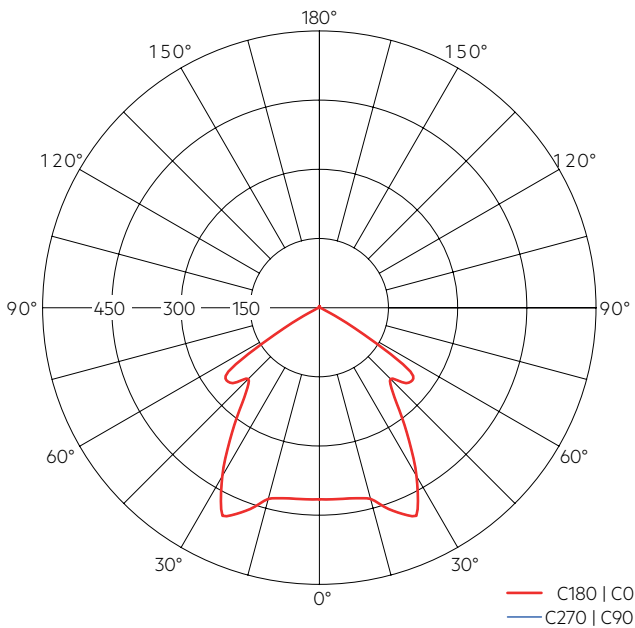

8.2 Escape route

EM R2A PRO 2W – Spacing data for 2m escape route^①

Height	Centre to end ^②		Centre to centre ^③	
	Max. spacing	Diversity	Max. spacing	Diversity
Transversal > 1 lux				
2.5 m	2.00 m	0.102	5.55 m	0.101
3.0 m	1.90 m	0.152	5.70 m	0.146
4.0 m	1.90 m	0.260	5.55 m	0.255
5.0 m	1.95 m	0.421	5.35 m	0.387
6.0 m	1.70 m	0.584	5.40 m	0.546
7.0 m	1.20 m	0.805	5.55 m	0.721
8.0 m	-	-	5.20 m	0.906
9.0 m	-	-	3.95 m	0.917
10.0 m	-	-	2.60 m	0.923
11.0 m	-	-	0.65 m	0.999
12.0 m	-	-	-	-
13.0 m	-	-	-	-
14.0 m	-	-	-	-
Longitudinal > 1 lux				
2.5 m	6.35 m	0.077	15.60 m	0.074
3.0 m	6.30 m	0.109	17.15 m	0.107
4.0 m	7.00 m	0.190	18.10 m	0.193
5.0 m	7.40 m	0.297	19.15 m	0.291
6.0 m	7.00 m	0.425	20.20 m	0.409
7.0 m	5.90 m	0.580	21.00 m	0.545
8.0 m	-	-	20.55 m	0.684
9.0 m	-	-	14.85 m	0.659
10.0 m	-	-	12.55 m	0.717
11.0 m	-	-	8.35 m	0.728
12.0 m	-	-	-	-
13.0 m	-	-	-	-
14.0 m	-	-	-	-

Luminous flux: 235 lm.

^① Maintenance factor = 0,9, photometric data available on request.

^② Distance between module and wall.

^③ Distance between two modules.

Light distribution

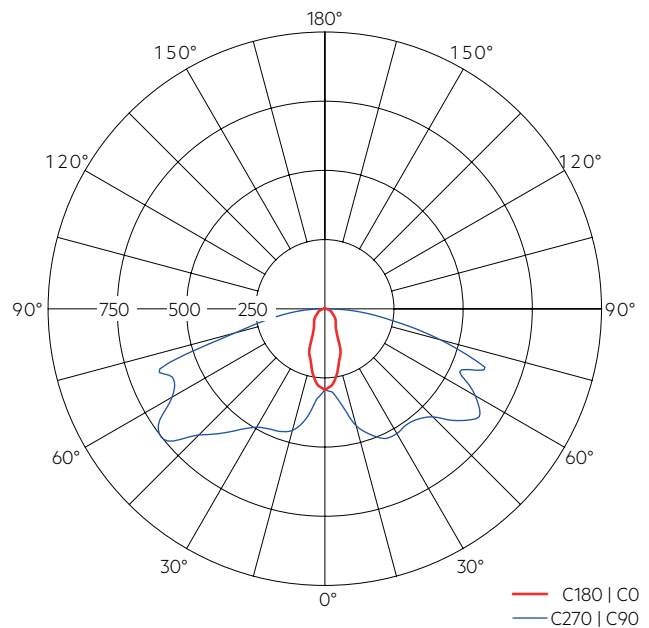

EM R2A PRO 3W – Spacing data for 2m escape route[®]

Height	Centre to end [®]		Centre to centre [®]	
	Max. spacing	Diversity	Max. spacing	Diversity
Transversal > 1 lux				
2.5 m	3.40 m	0.026	7.65 m	0.026
3.0 m	3.80 m	0.038	8.70 m	0.037
4.0 m	4.15 m	0.065	10.40 m	0.066
5.0 m	2.45 m	0.101	10.75 m	0.101
6.0 m	2.50 m	0.153	10.15 m	0.145
7.0 m	2.65 m	0.201	6.90 m	0.187
8.0 m	2.75 m	0.264	7.05 m	0.237
9.0 m	2.80 m	0.335	7.30 m	0.298
10.0 m	2.80 m	0.406	7.55 m	0.362
11.0 m	2.65 m	0.499	7.75 m	0.439
12.0 m	2.45 m	0.590	7.90 m	0.528
13.0 m	2.15 m	0.691	8.00 m	0.622
14.0 m	1.75 m	0.801	7.90 m	0.734
Longitudinal > 1 lux				
2.5 m	6.00 m	0.026	13.30 m	0.026
3.0 m	6.75 m	0.037	15.05 m	0.037
4.0 m	6.80 m	0.065	18.35 m	0.065
5.0 m	7.00 m	0.102	19.70 m	0.101
6.0 m	7.30 m	0.148	19.45 m	0.145
7.0 m	7.55 m	0.199	19.90 m	0.197
8.0 m	7.65 m	0.260	20.60 m	0.256
9.0 m	7.65 m	0.328	21.15 m	0.320
10.0 m	7.50 m	0.406	21.55 m	0.389
11.0 m	7.20 m	0.494	21.75 m	0.468
12.0 m	6.85 m	0.583	21.85 m	0.552
13.0 m	6.20 m	0.687	21.80 m	0.641
14.0 m	5.30 m	0.795	21.50 m	0.732

Luminous flux: 343 lm.

[®] Maintenance factor = 0.9, photometric data available on request.

[®] Distance between module and wall.

[®] Distance between two modules.

Light distribution

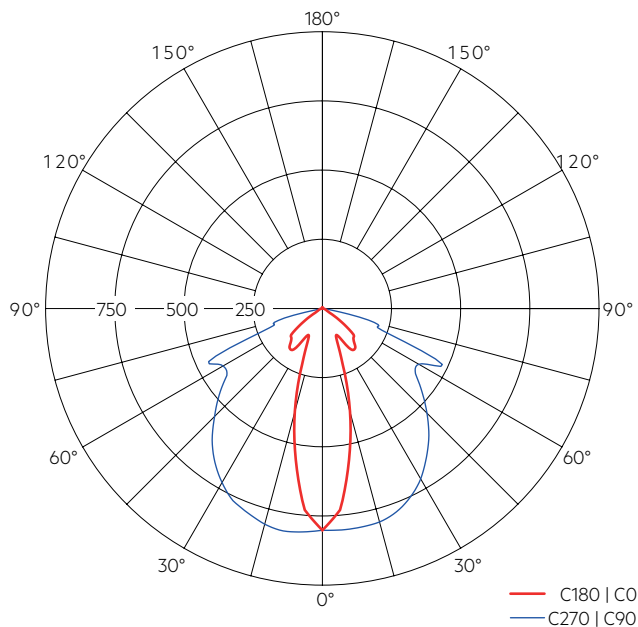

9. Miscellaneous

9.1 Battery replacement

After a battery replacement and a subsequent full charge cycle (24 h) a duration test is mandatory to prove that with the new battery the rated duration is achieved.



Do not damage battery and other components during battery replacement.

9.2 Black Box data recording

Recording of several parameters only accessible for Tridonic.

9.3 Additional information

Additional technical information at www.tridonic.com → Technical Data

The light source of this luminaire is not replaceable; when the light source reaches its end of life replace the whole luminaire. Lifetime declarations are informative and represent no warranty claim. No warranty if device was opened.