

**EM ready2apply BASIC 4 W SM**

EM ready2apply



**Product description**

- \_ LED emergency module suitable for surface mounted installation
- \_ Complete set with integrated electronics, LED module, heat sink, optics and battery
- \_ Includes click-in multi-lens option for anti-panic, escape route and spot illumination
- \_ Emergency lighting function for manual testing
- \_ BESA compatible mounting
- \_ EM = Emergency

**Properties**

- \_ Luminous flux 400 lm
- \_ Very low stand-by power loss
- \_ Non-maintained variants
- \_ 1 or 3 h rated duration (separate variants)
- \_ Simple connection of Lithium Iron Phosphate battery with plug-in system
- \_ White or black housing colour options
- \_ 5 years guarantee electronic (LED driver) (conditions at <https://www.tridonic.com/en/int/services/manufacture-guarantee-conditions>)
- \_ 5 years guarantee for LiFePO4 batteries (conditions at <https://www.tridonic.com/en/int/services/manufacture-guarantee-conditions>)

**Website**

<http://www.tridonic.com/89800983>



**EM ready2apply BASIC 4 W SM**

EM ready2apply

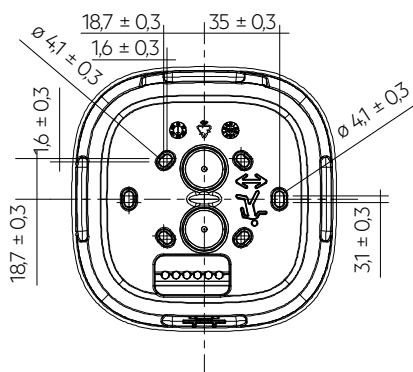
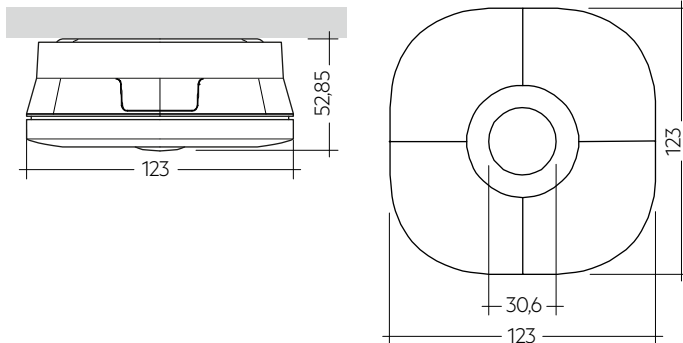

**Ordering data**

Type	Article number	Colour	Design	Rated duration	Number of cells	Packaging, carton	Packaging, pallet	Weight per pc.
EM R2A BASIC NM 114 SMh	89800983	White	high	1 h	2	1 pc(s).	400 pc(s).	0.274 kg
EM R2A BASIC NM 134 SMh	89800984	White	high	3 h	4	1 pc(s).	400 pc(s).	0.274 kg
EM R2A BASIC NM 114 SMh-B	89800989	Black	high	1 h	2	1 pc(s).	400 pc(s).	0.274 kg
EM R2A BASIC NM 134 SMh-B	89800990	Black	high	3 h	4	1 pc(s).	400 pc(s).	0.274 kg

**Technical data**

Rated supply voltage	220 – 240 V
Input voltage range AC (tolerance for safety)	198 – 264 V
Input voltage range AC (tolerance for performance)	198 – 254 V
Mains frequency	50 / 60 Hz
Overvoltage protection	320 V (for 48 h)
Starting time (Emergency operation)	< 0.5 s from detection of emergency event
Output current tolerance	± 5 %
LF current ripple	± 5 %
Ambient temperature range	+5 ... +40 °C
Mains voltage changeover threshold	According to EN 60598-2-22
Type of protection	IP20
Impact protection degree <sup>①</sup>	IK07
Protection class	II
Colour temperature	6,500 K
Colour tolerance	Mac Adams 3
Colour rendering index CRI	> 80
Lifetime	up to 50,000 h

Approval marks



Standards

according to EN 50172, EN 55015, EN 60068-2-6, EN 60068-2-30, EN 60598-1, EN 60598-2-2, EN 60598-2-22, EN 61000-3-2, EN 61000-3-3, EN 61347-1, EN 61347-2-7, EN 61347-2-13, EN 61547, acc. to EN 62034, EN 62384, EN 62386-101, EN 62386-102, EN 62386-202, IEC 62133 (related to Lithium Iron battery), UN 38.3 (related to Lithium Iron battery), EN 62031, EN 62471

Specific technical data

Type	Number of battery cells	Rated duration	Mains current (230 V, 50 Hz), non-maintained		Mains power (230 V, 50 Hz), non-maintained		Typ. $\lambda$ (at 230 V, 50 Hz, charging)	Typ. output current	Typ. forward voltage	Output power
			Charging	Charger off	Charging	Charger off				
<b>Normal operation</b>										
EM R2A BASIC NM 114 SMh	2	1 h	21 mA	11 mA	2.5 W	0.7 W	0.5C	-	-	-
EM R2A BASIC NM 134 SMh	4	3 h	21 mA	11 mA	2.5 W	0.7 W	0.5C	-	-	-
EM R2A BASIC NM 114 SMh-B	2	1 h	21 mA	11 mA	2.5 W	0.7 W	0.5C	-	-	-
EM R2A BASIC NM 134 SMh-B	4	3 h	21 mA	11 mA	2.5 W	0.7 W	0.5C	-	-	-
<b>Emergency operation</b>										
EM R2A BASIC NM 114 SMh	2	1 h	-	-	-	-	-	254 mA	12 V	3 W
EM R2A BASIC NM 134 SMh	4	3 h	-	-	-	-	-	254 mA	12 V	3 W
EM R2A BASIC NM 114 SMh-B	2	1 h	-	-	-	-	-	254 mA	12 V	3 W
EM R2A BASIC NM 134 SMh-B	4	3 h	-	-	-	-	-	254 mA	12 V	3 W

① IK rating valid for lens

LiFePO4 Battery pack 3.0 Ah

Accessory



**Product description**

- \_ High temperature LiFePO4 cells for use with EM ready2apply surface mounted emergency lighting units
- \_ 6 year design life (up to 30 °C ambient temperature)
- \_ 4 year design life (up to 40 °C ambient temperature)
- \_ 5 years guarantee (conditions at <https://www.tridonic.com/en/int/services/manufacturer-guarantee-conditions>)

**Properties**

- \_ Certified quality manufacturer
- \_ Charge efficiency > 90 %
- \_ Low self discharge
- \_ Simple connection with plug-in system
- \_ Protection and monitoring circuit built into battery enclosure
- \_ Deep discharge protection
- \_ Suitable for emergency lighting equipment as per IEC 60598-2-22



**Website**

<http://www.tridonic.com/28003554>



LiFeGuard

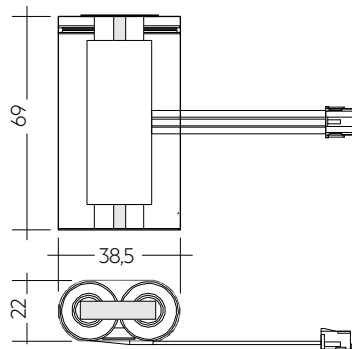

**Ordering data**

Type	Article number	Capacity	Packaging, carton	Weight per pc.
PACK-LiFePO4 3.0Ah 2A CON R2A SM	28003554	3 Ah	75 pc(s).	0.104 kg

## 1. Standards

according to EN 50172  
 EN 55015  
 EN 60068-2-6  
 according to EN 60068-2-30  
 EN 60598-1  
 EN 60598-2-2  
 EN 60598-2-22  
 EN 61000-3-2  
 EN 61000-3-3  
 EN 61347-1  
 EN 61347-2-7  
 EN 61347-2-7/A1  
 EN 61347-2-13  
 EN 61347-2-13/A1  
 EN 61547  
 according to EN 62034  
 EN 62384  
 EN 62386-101  
 EN 62386-102  
 EN 62386-202  
 IEC 62133 (related to Lithium Iron battery)  
 UN 38.3 (related to Lithium Iron battery)  
 EN 62031  
 EN 62471

### 1.1 Glow-wire test

according to EN 60598-1 with increased temperature of 850 °C passed.

## 2. Thermal data

### 2.1 Temperature range

According to the standard IEC 60598-1 a LED Driver for remote installation has a max. case temperature of 90 °C. The ambient temperature range  $t_a$  for the EM R2A BASIC is defined to meet this requirement.

### 2.2 Expected lifetime

Average lifetime 50,000 hours under rated conditions with a failure rate of less than 10 %. Average failure rate of 0.2 % per 1000 operating hours.

#### Expected lifetime

Type	$t_a$	25 °C	35 °C	40 °C
EM R2A BASIC	lifetime	> 100,000 h	> 50,000 h	50,000 h

### 2.3 Storage conditions

- Humidity: max. 60 % relative humidity not condensed

Note: The devices have to be within the specified temperature range ( $t_a$ ) before they are operated.

- Store batteries within the specified temperature range in low humidity conditions. Optimal storage conditions are:
  - Temperature: -20 ... +35 °C for up to 15 months
  - Relative humidity: 65 % ±5 %
- Avoid atmosphere with corrosive gas
- Disconnect batteries before store or delivery
- Avoid storage of discharged batteries

## 3. Installation / Wiring

### 3.1 Lens assembly

- Wear gloves when mounting the lens
- Take care of the mounting direction of the escape route lens
- Use screwdriver for replacing/removing lens
  - + 2. Push lens clips with screwdriver via openings on both sides
  3. Remove lens

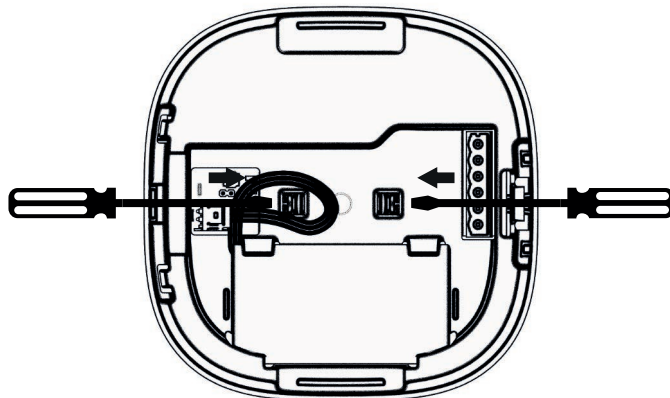

### 3.2 Luminaire assembly

- Back box preparation:
  - For rear entry: 2 drill locations are provided for a 20 mm hole
  - For side entry (use of deep back box): 3 locations are provided for use with 20 mm cable glands.
- If required a M3 x 10 self tapping screw (not supplied) can be used to secure the front plate to the back box. Drill a 3 mm hole in the back box indent.
- Fix the back plate to the ceiling (BESA compatible mounting)  
 Note: direction arrows allowing correct orientation for corridor lens.
- Change lenses if required (pre-fitted with anti panic lens)
- Wiring of the mains terminal block will require a suitable tool to open the cage clamp (size 3.5 x 0.5 mm blade)
- Plug battery into connector
- Fix front plate to back box: locating battery side tabs first, push home, a positive click will be heard when front plate is inserted correctly
- Apply power and the green charge indicator LED will be illuminated
- The deep back box has a parking facility for up to 6 Wago 2773 series connectors (not supplied) to aid through wiring cable management



When drilling prevent damage to internal components.  
 Do not damage any components during battery replacement.

If an impact protecting rating of above IK03 to a max. of IK07 is required, use an M3x10 self-tapping screw for the assembly.

### 3.3 Wiring diagrams

220–240 V  
50/60 Hz

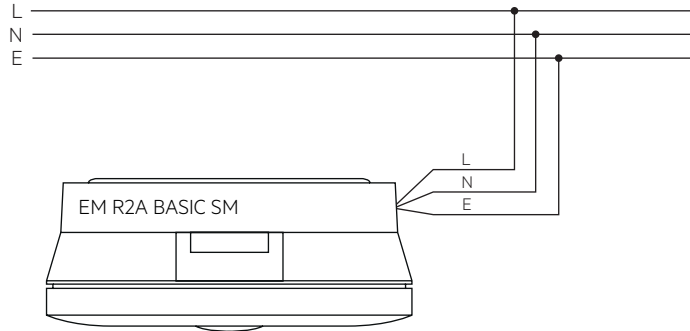

Note: Battery must be connected before mains connection.

### 3.4 Wiring type and cross-section

#### Wiring

Mains (N, L): blue, brown  
Earth terminal (E)

Cable: low smoke, halogen free

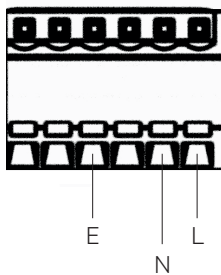
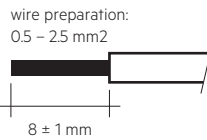

The installation of the luminaire has to be done by a qualified person.

### 3.5 Earth terminal (E)

The earth terminal is a loose connection without function. Use it to connect the earth wire to prevent it being loose in the luminaire. There is no earth connection required for the functionality of the EM ready2apply.

## 5. Electrical data

### 5.1 Maximum loading of automatic circuit breakers

Automatic circuit breaker type	C10	C13	C16	C20	B10	B13	B16	B20	Inrush current	
Installation Ø	1.5 mm <sup>2</sup>	1.5 mm <sup>2</sup>	2.5 mm <sup>2</sup>	4 mm <sup>2</sup>	1.5 mm <sup>2</sup>	1.5 mm <sup>2</sup>	2.5 mm <sup>2</sup>	4 mm <sup>2</sup>	$I_{max}$	time
<b>EM R2A BASIC</b>	180	260	260	260	90	130	130	130	10 A	120 µs

### 5.2 Insulation matrix

	Mains	Battery
Mains	-	••
Battery	••	-

•• Represents double or reinforced insulation

## 4. Mechanical data

### 4.1 Housing properties

- Polycarbonate white RAL 9016
- Polycarbonate black RAL 9005

### 4.2 Battery connection

Battery pack connection  
3-pole plug connection

### 4.3 Fixing

Surface Mount with options for cable entry by BESA, rear and side entry. To minimise dust ingress used cable entry holes will be drill out. Screw holes for BESA and general mounting are oval shape to allow adjustment and are pre-drilled to simplify the final installation.

### 5.3 Battery charge regime / discharge

#### EM R2A BASIC 4 W SM, 1 / 3 h

	<b>Type</b>	<b>EM R2A BASIC 4 W SM</b>
	<b>Article no.</b>	<b>89800983-84 / 89800989-90</b>
	<b>Cells</b>	<b>2 cells / 4 cells</b>
	<b>Duration</b>	<b>1 / 3 h</b>
Battery charge time	Initial	24 h
	Recharge	24 h
	Trickle charge	continuously and battery voltage controlled
Typ. charge current <sup>®</sup>	Initial charge	320 mA
	Recharge	320 mA
	Trickle charge	320 mA / 0 mA
Discharge current at 3.2 V (nominal)		1,250 mA

<sup>®</sup> Automatic recharge when battery voltage falls below 3.4 V. Charger off (0 mA) when battery voltage exceeds 3.6 V.

Note: Battery protected against operation at excessive temperatures (charging stopped when battery cell temperature < 0 °C or > 60 °C)

### 5.4 Battery selection for replacement

#### EM R2A BASIC 4 W, 1 / 3 h

				<b>Type</b>	<b>EM R2A BASIC NM 114</b>	<b>EM R2A BASIC NM 134</b>
				<b>Article no.</b>	<b>89800983, 89800989</b>	<b>89800984, 89800990</b>
				<b>Cells</b>	<b>2 cells</b>	<b>4 cells</b>
				<b>Duration</b>	<b>1</b>	<b>3 h</b>
<b>Technology and capacity</b>	<b>Design</b>	<b>Number of cells</b>	<b>Type</b>	<b>Article no.</b>	<b>Assignable batteries</b>	
LiFePO <sub>4</sub> 3 Ah	side by side	1 + 1	<b>ACCU-LiFePO4 3.0Ah 2B CON R2A SM</b>	<b>28003554</b>	•	
LiFePO <sub>4</sub> 6 Ah	side by side	2 + 2	<b>ACCU-LiFePO4 6.0Ah 2B CON R2A SM</b>	<b>28004233</b>		•

Note: If the rated duration of operation cannot be reached the battery must be replaced. Remove mains during battery replacement.

## 6. Functions

### 6.1 Status indication

The indication LED is integrated in the bezel. A green LED indicates that charging current is flowing into the battery.

The battery is protected against operation at excessive temperatures (charging stops and indication LED turns off when battery cell temperature < 0 °C or > 60 °C).

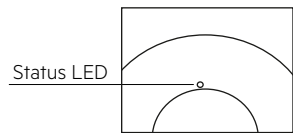

### 6.2 Testing

Emergency operation can be manually tested by removal of the mains supply.

### 6.3 Technical data batteries

#### Accu Lithium Iron Phosphate

International designation	IFpR 19/66
Battery voltage/cell	3.2 V
Single cell dimensions	
Diameter	18 mm
Height	65 mm
Capacity two cell pack	3.0 Ah
Capacity four cell pack	6.0 Ah
Max. short term temperature (reduced lifetime)	70 °C
Max. number discharge cycles	50 cycles total
Packing quantity	1 pc. per carton

Comply with UN 38.3 and IEC 62133 (safety testing) protected against over charge, over discharge, charging at excessive temperatures, short-circuit and over current.

For battery data see separate data sheet.

## 7. Optical properties

### 7.1 Anti panic

#### Max. spacing for >0.5 lux<sup>①</sup>

Height	Centre to end <sup>②</sup>		Centre to centre <sup>③</sup>	
	Trans	Axial	Trans	Axial
2.5 m	3.30	3.30	7.85	7.85
3.0 m	3.80	3.80	9.25	9.25
3.5 m	4.20	4.20	10.50	10.50
4.0 m	4.55	4.55	11.65	11.65
5.0 m	5.25	5.25	13.65	13.65
6.0 m	4.55	4.55	15.15	15.15
7.0 m	4.75	4.75	16.70	16.70
8.0 m	4.85	4.85	17.85	17.85
9.0 m	4.90	4.90	18.05	18.05
10.0 m	5.00	5.00	18.70	18.70
11.0 m	5.05	5.05	18.10	18.10
12.0 m	5.05	5.05	18.10	18.10
13.0 m	5.05	5.05	18.50	18.50
14.0 m	5.05	5.05	18.95	18.95

All values for  $t_a = 25\text{ °C}$

Luminous flux: 400 lm

<sup>①</sup> Maintenance factor = 0.8, photometric data available on request

<sup>②</sup> Distance between module and wall

<sup>③</sup> Distance between two modules

#### Light distribution

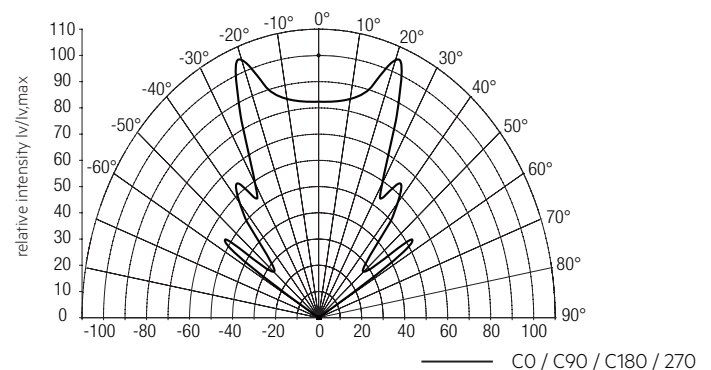

### 7.2 Escape route

#### Max. spacing for >1.0 lux<sup>①</sup>

Height	Centre to end <sup>②</sup>		Centre to centre <sup>③</sup>	
	Trans	Axial	Trans	Axial
2.5 m	5.50	3.15	11.95	6.95
3.0 m	6.35	3.65	13.90	8.05
3.5 m	7.00	4.00	15.70	9.00
4.0 m	7.20	4.20	17.35	9.90
5.0 m	6.95	4.05	19.15	11.25
6.0 m	7.20	2.15	20.05	10.05
7.0 m	7.40	2.30	19.70	9.35
8.0 m	7.65	2.45	20.20	8.70
9.0 m	7.80	2.55	20.55	6.25
10.0 m	7.75	2.60	21.05	6.60
11.0 m	7.55	2.65	21.55	6.90
12.0 m	7.25	2.60	21.95	7.20
13.0 m	6.75	2.40	22.15	7.35
14.0 m	6.10	2.10	21.95	7.40

All values for  $t_a = 25\text{ °C}$

Luminous flux: 400 lm

<sup>①</sup> Maintenance factor = 0.8, photometric data available on request

<sup>②</sup> Distance between module and wall

<sup>③</sup> Distance between two modules

Light distribution

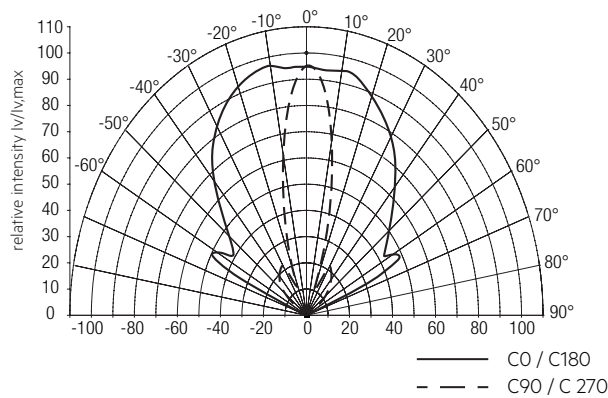

7.3 Spot

Max. spacing for >0.5 lux / > 5 lux<sup>®</sup>

Minimum illuminance	Height	Centre to end <sup>®</sup>		Centre to centre <sup>®</sup>	
		Trans	Axial	Trans	Axial
0.5	2.5 m	1.65	1.65	7.90	7.90
	3.0 m	1.95	1.95	7.90	7.90
	3.5 m	2.30	2.30	7.90	7.90
	4.0 m	2.60	2.60	8.05	8.05
	5.0 m	3.90	3.90	10.05	10.05
	6.0 m	3.90	3.90	12.10	12.10
	7.0 m	4.55	4.55	14.10	14.10
	8.0 m	4.35	4.35	15.10	15.10
	9.0 m	3.55	3.55	15.90	15.90
	10.0 m	3.40	3.40	16.75	16.75
	11.0 m	3.45	3.45	17.45	17.45
	12.0 m	3.55	3.55	17.80	17.80
	13.0 m	3.65	3.65	17.05	17.05
	14.0 m	3.75	3.75	16.05	16.05
5.0	2.5 m	1.40	1.40	4.70	4.70
	3.0 m	1.05	1.05	5.15	5.15
	3.5 m	1.10	1.10	5.50	5.50
	4.0 m	1.15	1.15	5.45	5.45
	5.0 m	1.25	1.25	4.95	4.95
	6.0 m	1.30	1.30	4.25	4.25
	7.0 m	1.30	1.30	4.35	4.35
	8.0 m	1.20	1.20	4.55	4.55
	9.0 m	1.15	1.15	4.75	4.75
	10.0 m	1.05	1.05	4.95	4.95
	11.0 m	0.95	0.95	5.05	5.05
	12.0 m	0.85	0.85	5.15	5.15
	13.0 m	0.60	0.60	5.10	5.10
	14.0 m	0.20	0.20	5.00	5.00

All values for ta = 25 °C

Luminous flux: 400 lm

<sup>®</sup> Maintenance factor = 0.8, photometric data available on request

<sup>®</sup> Distance between module and wall

<sup>®</sup> Distance between two modules

Light distribution

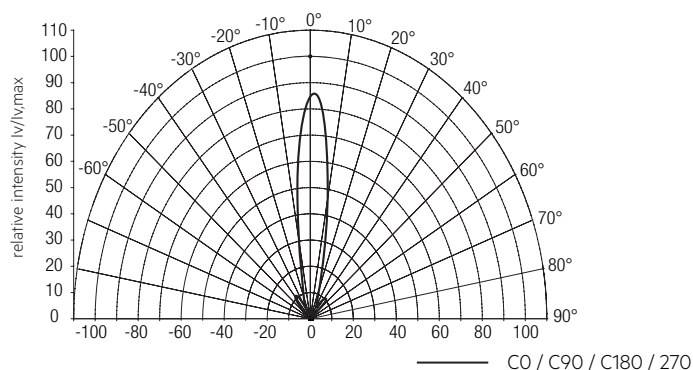

8. Miscellaneous

8.1 Battery replacement

After a battery replacement and a subsequent full charge cycle (24 h) a duration test is mandatory to prove that with the new battery the rated duration is achieved.



Do not damage battery and other components during battery replacement.

8.2 Black Box data recording

Recording of several parameters only accessible for Tridonic.

8.3 Additional information

Additional technical information at [www.tridonic.com](http://www.tridonic.com) → Technical Data

The light source of this luminaire is not replaceable; when the light source reaches its end of life replace the whole luminaire. Lifetime declarations are informative and represent no warranty claim. No warranty if device was opened.