

**EM powerLED PRO EZ-3 4 W**

Combined emergency lighting LED driver 1 – 4 W

**Product description**

- \_ Emergency lighting LED driver with DALI interface and automatic test function
- \_ For self-contained emergency lighting
- \_ SELV for output voltage < 60 V DC
- \_ Low profile casing (21 x 30 mm cross-section)
- \_ EM = Emergency
- \_ 5 years guarantee (conditions at <https://www.tridonic.com/en/int/services/manufacturer-guarantee-conditions>)

**Properties**

- \_ Non maintained operation
- \_ DALI interface for controlled testing and monitoring
- \_ Constant current mode
- \_ With either screw or clip fastening (clip-fix)
- \_ 1, 2 or 3 h rated duration
- \_ Selectable operating time (jumper)
- \_ Output power limitation
- \_ Two-colour status display LED
- \_ Automatic restart after LED replacement
- \_ Electronic multi-level charge system
- \_ SELV classified (outputs powerLED, battery, status LED, test switch)
- \_ Polarity reversal protection for battery
- \_ Deep discharge protection
- \_ Very low energy consumption from the battery after activation of the deep discharge protection
- \_ Short-circuit-proof battery connection
- \_ Addressing function, patented ("EZ easy addressing")
- \_ Emergency lighting LEDs available
  - Tests:
  - \_ Status of the battery
  - \_ Status of the LED
  - \_ Charge condition
  - \_ Function test
  - \_ Duration test

**Batteries**

- \_ High-temperature cells
- \_ NiCd or NiMH batteries
- \_ 4 year design life
- \_ 2 years guarantee (conditions at <https://www.tridonic.com/en/int/services/manufacturer-guarantee-conditions>)
- \_ For battery compatibility refer to data sheet

**Website**

<http://www.tridonic.com/89800126>



**EM powerLED PRO EZ-3 4 W**

Combined emergency lighting LED driver 1 – 4 W

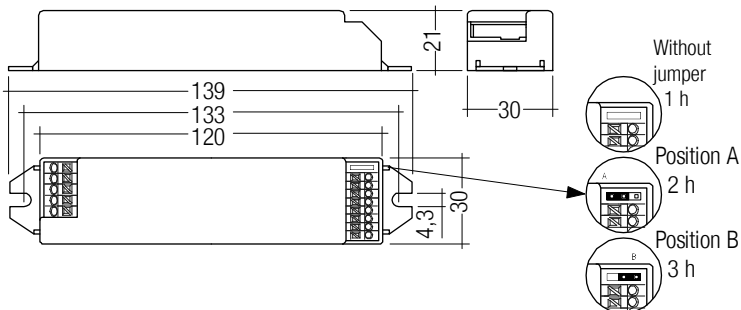

**Ordering data**

Type	Article number	Rated duration	Max. number of LEDs	Wattage	Packaging, carton	Packaging, pallet	Weight per pc.
<b>Screw fastening version</b>							
EM powerLED 4 W PRO EZ-3 SCREW-FIX	89800126	1/2/3 h	2	4 W	25 pc(s).	1,200 pc(s).	0.068 kg
EM powerLED 4 W PRO NiMH SCREW-FIX	89800446	1/2/3 h	2	4 W	25 pc(s).	1,200 pc(s).	0.068 kg

**Technical data**

Rated supply voltage	220 – 240 V
Mains frequency	50 / 60 Hz
Forward voltage range LED module (1 x LED)	2.8 – 3.4 V
Forward voltage range LED module (2 x LED)	5.6 – 6.8 V
Max. open circuit voltage	10 V
LED current in emergency operation (1 x LED)	1,000 mA
LED current in emergency operation (2 x LED)	700 mA
Typ. output power (1 x LED)	3.4 W
Typ. output power (2 x LED)	4.5 W
Starting time	0.23 s from detection of emergency event
Overvoltage protection	320 V (for 1 h)
Battery discharge current	Refer to data sheet
Max. casing temperature $t_c$	70 °C
Ambient temperature $t_a$	-25 ... +45 °C
Mains voltage changeover threshold	According to EN 60598-2-22
Type of protection	IP20
Lifetime	up to 50,000 h
Guarantee (conditions at <a href="http://www.tridonic.com">www.tridonic.com</a> )	5 Year(s)
Dimensions L x W x H	139 x 30 x 21 mm

**Approval marks**



**Standards**

according to EN 50172, according to EN 60598-2-22, EN 61347-2-7, EN 61347-2-13, EN 62384, EN 62034, EN 55015, EN 61000-3-2, EN 61000-3-3, EN 61547, EN 60068-2-29, EN 60068-2-30, EN 60068-2-64, EN 62386 (acc. to DALI standard V1)

## Specific technical data

Type	Rated duration	Typ. $\lambda$ Cat 230 V, 50 Hz	Mains current in charging operation			Mains power in charging operation		
			Initial charge	Fast recharge	Trickle charge <sup>①</sup>	Initial charge	Fast recharge	Trickle charge <sup>①</sup>
<b>EM powerLED 4 W PRO EZ-3 SCREW-FIX</b>	1 h	0.34C	21.0 mA	27.5 mA	15.2 mA	2.0 W	3.0 W	1.2 W
<b>EM powerLED 4 W PRO EZ-3 SCREW-FIX</b>	2 h	0.34C	27.5 mA	32.4 mA	21.0 mA	3.0 W	3.7 W	2.0 W
<b>EM powerLED 4 W PRO EZ-3 SCREW-FIX</b>	3 h	0.34C	27.5 mA	32.4 mA	21.0 mA	3.0 W	3.7 W	2.0 W
<b>EM powerLED 4 W PRO NiMH SCREW-FIX</b>	1 h	0.34C	19.0 mA	24.0 mA	13.0 mA	1.7 W	2.4 W	1.0 W
<b>EM powerLED 4 W PRO NiMH SCREW-FIX</b>	2 h	0.34C	30.0 mA	32.0 mA	13.0 mA	3.1 W	3.3 W	1.1 W
<b>EM powerLED 4 W PRO NiMH SCREW-FIX</b>	3 h	0.34C	30.0 mA	32.0 mA	13.0 mA	3.1 W	3.3 W	1.1 W

① For EM powerLED 4 W NiMH: average over 20 min. (4 min. charge / 16 min. off)

## Test switch EM2

Accessory



## Product description

- \_ For connection to the emergency lighting unit
- \_ For checking the device function
- \_ Dielectric strength: 1,500 V AC for 60 seconds
- \_ Lead length 0.55m
- \_ Mounting hole 7,0 mm diameter

## Website

<http://www.tridonic.com/89805277>



## Ordering data

Type	Article number	Packaging, bag	Packaging, carton	Weight per pc.
Test switch EM 2	89805277	25 pc(s).	1,800 pc(s).	0.009 kg

## Approval marks

RoHS

## Status indication bi-colour LED EM

Accessory



## Product description

- \_ Two-colour status display LED
- \_ Green: system OK, red: fault

## Website

<http://www.tridonic.com/89899720>



## Ordering data

Type	Article number	Packaging, bag	Packaging, carton	Weight per pc.
LED EM bi-colour	89899720	25 pc(s).	200 pc(s).	0.016 kg
LED EM bi-colour, high brightness	89899753	25 pc(s).	200 pc(s).	0.016 kg

## Approval marks

RoHS

EMpLED Strain-relief set 200x43x25.5mm

Accessory

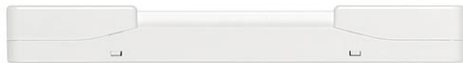

**Product description**

- \_ Optional strain-relief for independent applications
- \_ Transforms the LED driver into a fully class II compatible LED driver (e.g. ceiling installation)
- \_ Easy and tool-free mounting to the LED driver, screwless cable-clamp channels with strain-relief (200 x 43 x 25.5 mm)

**Website**

<http://www.tridonic.com/28004033>



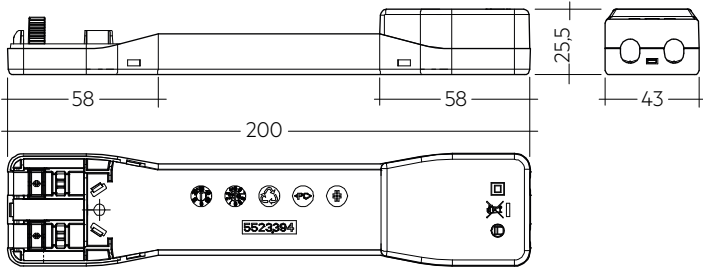

Permissible cable jacket diameter 2.2 – 9 mm

**Ordering data**

Type	Article number	Packaging, carton	Weight per pc.
EM pLED SR	28004033	10 pc(s).	0.05 kg

**Approval marks**



## 1. Standards

- EN 61347-2-7
- EN 61347-2-13
- EN 62384
- EN 55015
- EN 61000-3-2
- EN 61000-3-3
- EN 61547
- EN 60068-2-64
- EN 60068-2-29
- EN 60068-2-30
- EN 62386 (according to DALI standard V1)
- according to EN 50172
- according to EN 60598-2-22
- according to EN 62034

### 1.1 Glow-wire test

according to EN 61347-1 with increased temperature of 850 °C passed.

### 1.2 Insulation and electric strength testing of luminaires

Electronic devices can be damaged by high voltage. This has to be considered during the routine testing of the luminaires in production.

According to IEC 60598-1 Annex Q (informative only!) or ENEC 303-Annex A, each luminaire should be submitted to an insulation test with 500 V<sub>DC</sub> for 1 second. This test voltage should be connected between the interconnected phase and neutral terminals and the earth terminal. The insulation resistance must be at least 2 M $\Omega$ .

As an alternative, IEC 60598-1 Annex Q describes a test of the electrical strength with 1,500 V<sub>AC</sub> (or 1,414 x 1,500 V<sub>DC</sub>). To avoid damage to the electronic devices this test must not be conducted.

## 2. Thermal details and lifetime

### 2.1 Lifetime

Average lifetime 50,000 hours under rated conditions with a failure rate of less than 10 %. Average failure rate of 0.2 % per 1000 operating hours.

### 3. Installation / Wiring

#### 3.1 Wiring diagrams

##### 3.1.1 Serial wiring with one or two LED modules

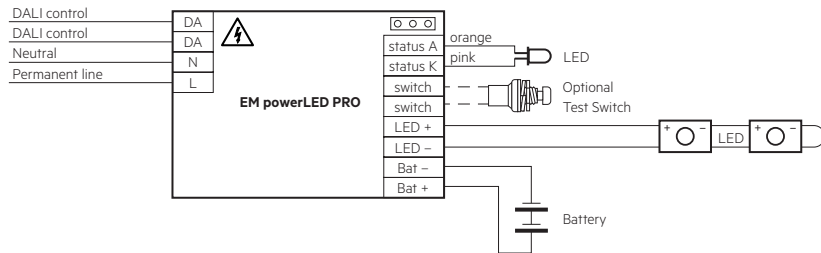

##### 3.1.2 Parallel wiring with multiple LED modules (3 - 12)

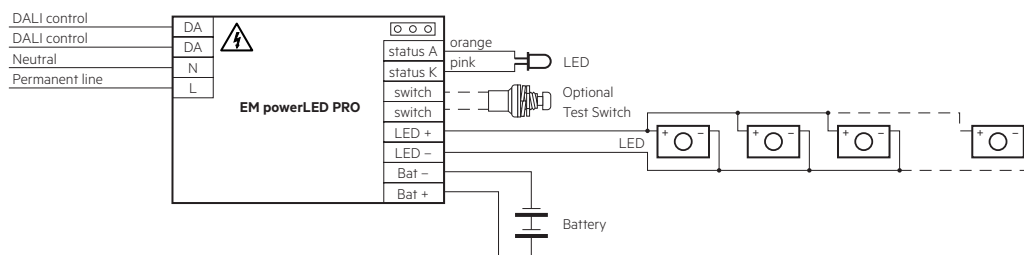

Take care that the LED is connected with the right polarity. LED that are connected to the EM powerLED PRO EZ-3 devices should have a reverse polarity protection device such as a schottky diodes fitted, otherwise irreversible damage could occur if the LED is connected in reverse polarity. Any protection device must be capable of handling in excess of 1,000 mA.

Note: Please ensure that at the terminal of the EM powerLED module the battery negative is not connected to the negative of the LED load.

##### 3.1.3 Manually tested emergency lighting with combined LED modules for general and emergency lighting

Due to the fact that independent circuits are used for general and emergency lighting it is important that the normal supply of the mains LED driver is switched off together with the permanent emergency supply prior to checking the operation of the emergency LEDs. If this is not done then it may not be possible to see that the emergency LEDs are operating. Use a circuit similar to that shown below.

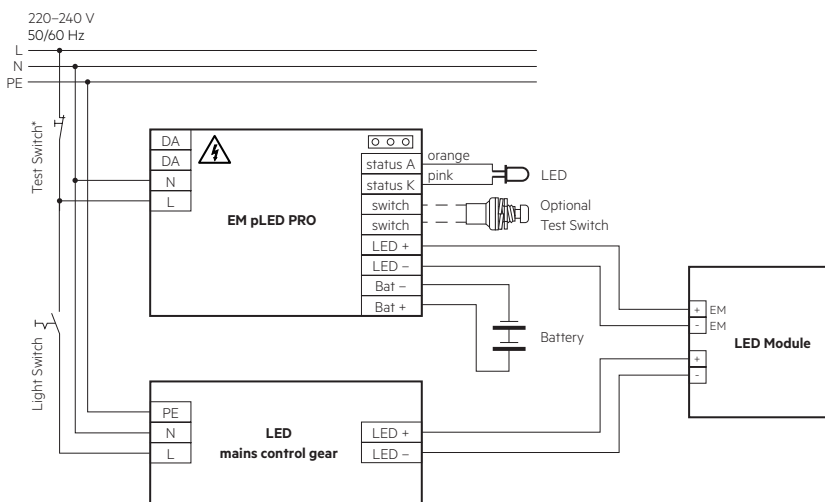

\* Use 230 V Test switch

3.1.4 Wireless set-up

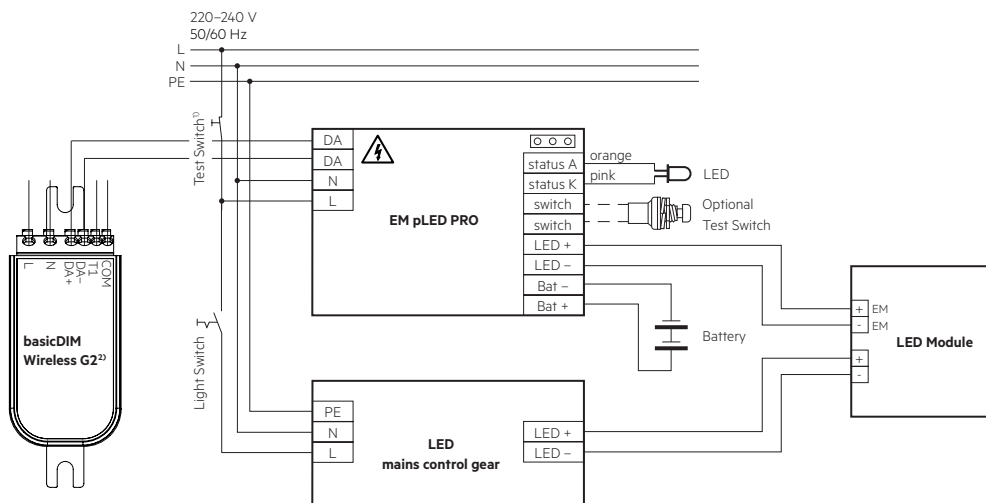

<sup>1)</sup> Use 230 V Test switch  
<sup>2)</sup> For further information see basicDIM Wireless datasheet at [www.tridonic.com](http://www.tridonic.com)

3.2 Wiring type and cross section

Wiring

mains (SL, N, L)  
 LED (LED +, LED -)

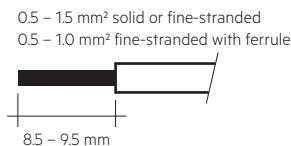

Wiring

batteries (Bat +, Bat -)  
 test switch (switch)  
 status indication LED (status K, A)

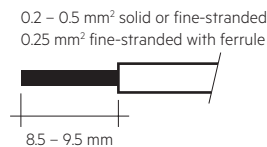

Use one wire for each terminal connector only.

3.3 Release of the wiring

Press down the "push button" and remove the cable from front.

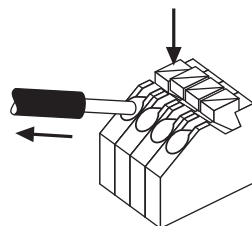

3.4 Wiring instructions

- The EM powerLED terminals, battery, indicator LED and test switch terminals are classified as SELV. Keep the wiring of the DALI and the input terminals separated from the wiring of the SELV terminals or consider special wiring (double insulation, 6 mm creepage and clearance) when these connections should be kept SELV.
- The output to the LED is DC but has high frequency content at 125 kHz, which should be considered for good EMC compliance.
- EM powerLED leads should be separated from the mains and DALI connections and wiring for good EMC performance. With some luminaires it may be necessary to add a ferrite bead inductor to obtain satisfactory EMC performance.
- Maximum lead length on the EM powerLED terminals is 3m. For a good EMC performance keep the LED wiring as short as possible.

- The secondary wires (LED module) should be routed in parallel to ensure good EMC performance.
- Maximum lead length for the test switch and Indicator LED connection is 1 m. The test switch and Indicator LED wiring should be separated from the EM powerLED leads to prevent noise coupling.
- Battery leads are specified with 0.5 mm² cross section and a length of < 1.3 m.
- DALI terminals are mains proof.
- To avoid the damage of the control gear, the wiring must be protected against short circuits to earth (sharp edged metal parts, metal cable clips, louver, etc.).

3.5 Max. lead insulation diameter

Battery	2.1mm
Test switch	2.1mm
Indicator LED	2.1mm

3.6 Maximum lead length

Battery	1m
LED	3m
status indication LED	1m

#### 4. Mechanical details

Case manufactured from polycarbonate.

LED bi-colour status indicator

- Green / red
- Mounting hole 6.5 mm diameter, 1 – 1.6 mm thickness
- Lead length 1,000 mm
- Insulation rating: 90 °C

Test switch

- Mounting hole 7.0 mm diameter
- Lead length 550 mm

Battery leads

- Quantity: 1 red and 1 black
- Length: 1,300 mm
- Wire type: 0.5 mm<sup>2</sup> solid conductor
- Insulation rating: 90 °C

Battery end termination

Push on 4.8 mm receptacle to suit battery spade fitted with insulating cover

Module end termination

8.0 mm stripped insulation

Two-piece batteries are supplied with a 200 mm lead with 4.8 mm receptacles at each end and insulating covers to connect the separate sticks together.

##### 4.1 Recommended fixing details for clip fixing

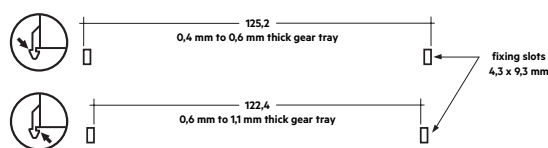

Max. torque at the clamping screw: 0.5 Nm / M4

#### 5. Electrical values

##### 5.1 Maximum loading of automatic circuit breakers

Automatic circuit breaker type	B10	C10	B13	C13	B16	C16	B20	C20	Inrush current	
Installation Ø	1.5 mm <sup>2</sup>	1.5 mm <sup>2</sup>	1.5 mm <sup>2</sup>	1.5 mm <sup>2</sup>	2.5 mm <sup>2</sup>	2.5 mm <sup>2</sup>	2.5 mm <sup>2</sup>	2.5 mm <sup>2</sup>	I <sub>max</sub>	time
<b>EM powerLED 4 W PRO EZ-3</b>	90	180	130	260	130	260	130	260	10 A	120 µs
<b>EM powerLED 4 W PRO EZ-3 NiMH</b>	90	180	130	260	130	260	130	260	10 A	120 µs

##### 5.2 Insulation matrix

	Mains	Switched Live	Battery, LED, Test switch, Indicator LED	DALI
Mains	–	•	••	•
Switched Live	•	–	••	•
Battery, LED, Test switch, Indicator LED	••	••	–	•
DALI	•	•	•	–



• Represents basic insulation

•• Represents double or reinforced insulation

DALI terminals are not SELV. Wire the terminals in accordance with the requirements of low voltage installations.

## 6. Functions

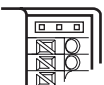
### 6.1 Duration link selection

Duration	Link Position
1 hr	 without jumper
2 hr	 position A
3 hr	 position B

### 6.2 Jumper selection

Module supplied with jumper in 3 hours position (position B).

The position of the link will only be read on first power up. If it is changed afterwards both the battery and mains supply must be disconnected for 10 seconds to enable the EM powerLED EZ-3 to read the new link position on reconnection of the battery and mains. It will lead to a false battery failure indication if the link is changed after installation without this reset.

### 6.3 Status indication

System status is indicated by a bi-colour LED and by a DALI status flag.

LED indication	Status	Kommentar
Permanent green	System OK	AC mode
Fast flashing green (0,1 sec on – 0,1 sec off)	Function test underway	
Slow flashing green (1 sec on – 1 sec off)	Duration test underway	
Red LED on	Load failure	Open circuit / Short circuit / LED failure ①
Slow flashing red (1 sec on – 1 sec off)	Battery failure	Battery failed the duration test or function / Battery is defect / Incorrect battery voltage
Fast flashing red (0,1 sec on – 0,1 sec off)	Charging failure	Incorrect charging current
Double pulsing green	Inhibit mode	Switching into inhibit mode via controller
Binary transmission of address via green/red LED	Address identification	During address identification mode
Green and red off	DC mode	Battery operation (emergency mode)

① If the EM powerLED is operated in non-maintained mode and an LED fault is detected, the red indicator LED will be illuminated and the output will be stopped. The unswitched mains supply must be switched off before the LED is changed in order that the new LED can be detected. A function or duration test will not reset the fault indication.

### 6.4 Testing

#### DALI Control

A DALI command from a suitable control unit can be used to initiate function and duration tests at individually selected times. Status flags are set for report back and data logging of results.

When a DALI bus has not been connected or when a DALI bus is connected but the DALI default DELAY and INTERVAL times have not been re-set by sending appropriate DALI commands, then the EM powerLED PRO EZ-3 will conduct self-tests in accordance with the default times set within the EEPROM. These default times are factory pre-set, in accordance with the DALI standard EN 62386-202, to conduct an automatic function test every 7 days and a duration test every 52 weeks. Since the DELAY time is factory pre-set to Zero, all units are tested at the same time. Test times can be

changed with a command over the DALI bus.

The DELAY and INTERVAL time values must be re-set when the emergency system test times are to be scheduled by a DALI control and monitoring system.

Note that once the default values have been set to Zero, tests will only be conducted following a command from the control system. If the DALI bus is disconnected the EM powerLED PRO EZ-3 does not revert to self-testing mode.

#### Commissioning

After installation of the luminaire and initial connection of the mains supply and battery supply to the EM powerLED PRO EZ-3 the unit will commence charging the batteries for 20 hours (initial charge). Afterwards the module will conduct a commissioning test for the full duration. The 20 hours recharge occurs also if a new battery is connected or the module exits the rest mode condition. The following automatic commissioning duration test is only performed when a battery is replaced and fully charged (after 20 hrs) and the interval time is not set to zero, otherwise the system is expected to perform the testing.

#### Functional test

The time of day and frequency of the 5 seconds function test can be set by the DALI controller. The default setting is a 5 seconds test on a weekly basis.

#### Duration test

The time of day and frequency of the duration test can be set by the DALI controller. The default setting is a duration test conducted every 52 weeks.

#### Prolong time

Prolong time can be set by the DALI controller. This is the delay time between return of the mains supply and the end of the emergency operation. The default prolong time is set as 0 minutes as specified within the DALI standard.

Indicator LED will stay off for the duration of the prolong time.

#### Timer reset functionality

The timer for function and duration test can be set to a particular time of the day by either pressing the test switch for longer than 10 seconds or cycling the unswitched line supply 5 times within 1 minute. The timer adjustment will enable the test start time to be defined manually at time in day when the timer was reset. It will also disable the adaptive test algorithm thereby forcing the unit to perform the test at the same time rather than it being defined by the adaptive algorithm. This function will only work provided the interval time is greater than zero (automatic test mode enabled). The delay timer value set when the unit was commissioned will be reloaded in order to randomise the tests between adjacent units.

The factory programmed delay offset (1 – 28 days) will be loaded after the reset into the delay timer for the function and duration test in order to randomize the tests between adjacent units.

#### Rest Mode / Inhibit Mode

Emergency operation is automatically started when the mains supply is switched off. If the Rest Mode is activated, the discharging of the battery will be minimized by switching off the LED output. If the Inhibit Mode has been activated before the mains supply is switched off, Rest Mode will be automatically switched on if the mains supply is switched off within 15 minutes. Rest Mode and Inhibit Mode can be initiated by the DALI controller. The REST command has to be sent after the mains supply has been disconnected and whilst the EM powerLED PRO is in emergency operation. The INHIBIT command has to be sent while the EM powerLED PRO is supplied by mains.

After a mains reset the EM powerLED PRO exits the Rest Mode. Rest Mode and Inhibit Mode can both be disabled by sending the RE-LIGHT/RESET INHIBIT command.

**Test switch**

An optional test switch can be wired to each EM powerLED PRO EZ-3. This can be used to initiate a 5 seconds function test by a short press < 1 second.

**DALI Controller**

DALI controllers and hardware/software solutions are available from Tridonic. Please refer to the Lighting controls section.

**6.5 Further technical data**

The EM powerLED has a unique power regulation circuit; this is designed to limit the total power drawn from the battery in the event of using LED's with a forward voltage (Vf) higher than 3.4 V.

In such cases the unit will reduce the LED current in order to maintain an acceptable drain current from the battery and hence meet the required duration time. This feature enables the EM powerLED PRO EZ-3 to have minimum battery count for a given range of LED's.

**7. Battery data**

**7.1 Battery selection**

EM powerLED 4W PRO EZ-3, 1 / 2 / 3 h

		Type	EM powerLED 4W PRO EZ-3		EM powerLED 4W PRO EZ-3 NiMH	
		Article no.	89800126		89800446	
		Cells	5 cells		5 cells	
		Duration	1 h	2 / 3 h	1 h	2 / 3 h
Technology and capacity	Design	Number of cells	Type	Article no.	Assignable batteries	
NiCd 4 Ah	stick	1 x 5	Accu-NiCd 5A 55	28002774	•	
D cells	stick + stick	3 + 2	Accu-NiCd 5C 55	89800090	•	
NiMH 2.2 Ah	stick	1 x 5	Accu-NiMH 5A	28002090	•	•
Cs cells	side by side	5 x 1	Accu-NiMH 5B	28002093	•	•
NiMH 4 Ah LA cells	stick + stick	2 + 3	Accu-NiMH 4Ah 5C CON	89800439		•

**7.2 Battery charge / discharge data**

EM powerLED 4W PRO EZ-3, 1 / 2 / 3 h

		Type	EM powerLED 4W PRO EZ-3		EM powerLED 4W PRO EZ-3 NiMH	
		Article no.	89800126		89800446	
		Cells	5 cells		5 cells	
		Duration	1 h	2 / 3 h	1 h	2 / 3 h
Battery charge time	Initial charge	20 h				
	Fast recharge	10 h	15 h	10 h	15 h	
	Trickle charge	continuously				
Charge current	Initial charge	130 mA	250 mA	130 mA	300 mA	
	Fast recharge	250 mA	330 mA	210 mA	330 mA	
	Trickle charge	60 mA	130 mA	127 mA / 4 min. 0 mA / 16 min.	201 mA / 4 min. 0 mA / 16 min.	
Discharge current		1,100 mA	1,100 mA	1,100 mA	1,100 mA	
Charge voltage range <sup>①</sup>		1.07 – 1.6 V per cell				
Discharge voltage range		1.6 – 1.07 V per cell				

<sup>①</sup> The battery will be charged below 1.07 V. The EM powerLED will indicate a battery fault. The emergency lighting LED driver will recharge the battery normally after running the test of 61347-2-7 CL 22.3 (abnormal operating conditions).

**7.3 Accu-NiCd****4.2 / 4.5 Ah**

Battery voltage/cell	1.2 V
Cell type	D
Case temperature range to ensure 4 years design life	+5 °C to +55 °C
Max. short term battery case temperature (shorter than 1 month over the battery lifetime)	70 °C
Max. number discharge cycles	4 cycles per year plus 4 cycles during commissioning
Max. storage time	6 months

**7.4 Accu-NiMH****2.2 Ah**

Battery voltage/cell	1.2 V
Cell type	Cs
Case temperature range to ensure 4 years design life	
When used with EM powerLED 4W PRO EZ-3	+5 °C to +50 °C
When used with EM powerLED 4W PRO EZ-3 NiMH	+5 °C to +55 °C
Max. short term battery case temperature (shorter than 1 month over the battery lifetime)	70 °C
Max. number discharge cycles	4 cycles per year plus 30 cycles during commissioning
Max. storage time	12 months

**4.0 Ah**

Battery voltage/cell	1.2 V
Cell type	LA
Case temperature range to ensure 4 years design life	
When used with EM powerLED 4W PRO EZ-3	+5 °C to +45 °C
When used with EM powerLED 4W PRO EZ-3 NiMH	+5 °C to +50 °C
Max. short term battery case temperature (shorter than 1 month over the battery lifetime)	70 °C
Max. number discharge cycles	4 cycles per year plus 30 cycles during commissioning
Max. storage time	12 months

**7.5 Batteries**

Connection method: 4.8 x 0.5 mm spade tag welded to end of cell

For stick packs this connection is accessible after the battery caps have been fitted.

To inhibit inverter operation disconnect the batteries by removing the connector from the battery spade tag.

For further information refer to corresponding battery datasheet.

**7.6 Short-circuit protection**

In case of a short circuit the battery protection opens the connection to the driver and the output is therefore free of voltage. The output will be reactivated again when the short circuit is removed.

**7.7 Storage, installation and commissioning**

Relevant information about storage conditions, installation and commissioning are provided in the battery datasheets.

**8. Miscellaneous****8.1 Mains-connected transformers**

The EM powerLED does not contain mains-connected windings of transformers.

**8.2 FELV control terminals**

FELV control terminals marked „Risk of electric shock“ are not safe to touch. Insulate circuits connected to any FELV control terminal for the Low Voltage supply voltage of the control gear. Protect terminals connected to the FELV circuit against accidental contact.

**8.3 Additional information**

Additional technical information at [www.tridonic.com](http://www.tridonic.com) → Technical Data

Lifetime declarations are informative and represent no warranty claim. No warranty if device was opened.