

EM powerLED PRO DIM SR 45 W

Combined emergency lighting LED driver

**Product description**

- _ Independent dimmable LED driver
- _ Emergency lighting LED driver with DALI interface and automatic test function
- _ For self-contained emergency lighting
- _ For LED modules with a forward voltage of 20 – 50 V
- _ SELV for output voltage < 60 V DC
- _ Compact plastic casing with strain relief
- _ EM = Emergency

Properties

- _ Output power 6 – 45 W
- _ Constant current LED operation
- _ 300 – 1,400 mA output current in mains operation, adjustable with I-SELECT 2 PLUG in steps of 25 mA or via DALI in steps of 1 mA
- _ Integrated emergency lighting unit
- _ 1, 2 or 3 h rated duration
- _ Operating time selectable with dip switch (2-way)
- _ Automatic shutdown of output if the forward voltage of the LED is out of range
- _ Two-colour status display LED
- _ Electronic multi-level charge system
- _ Pulse current charging for NiMH batteries
- _ Polarity reversal protection for battery
- _ Power-up fading at AC
- _ Protective features (overtemperature, short-circuit, overload, no-load, input voltage range, reduced surge amplification)
- _ Deep discharge protection
- _ Short-circuit-proof battery connection
- _ 5 years guarantee (conditions at <https://www.tridonic.com/manufacturer-guarantee-conditions>)

Interfaces

- _ one4all (DALI DT 1 & 6, DSI, switchDIM, corridorFUNCTION)
- _ Terminal blocks: 45° push terminals

Batteries

- _ High-temperature cells
- _ NiCd or NiMH batteries
- _ D, Cs, LA or LAL cells
- _ Battery box for independent use
- _ 4 year design life
- _ 2 years guarantee (conditions at <https://www.tridonic.com/manufacturer-guarantee-conditions>)
- _ For battery compatibility refer to data sheet

Website

<http://www.tridonic.com/89800434>



Spotlights



Downlights



Linear



Area



Floor | Wall



Free-standing



Street



Decorative



High bay

EM powerLED PRO DIM SR 45 W

Combined emergency lighting LED driver

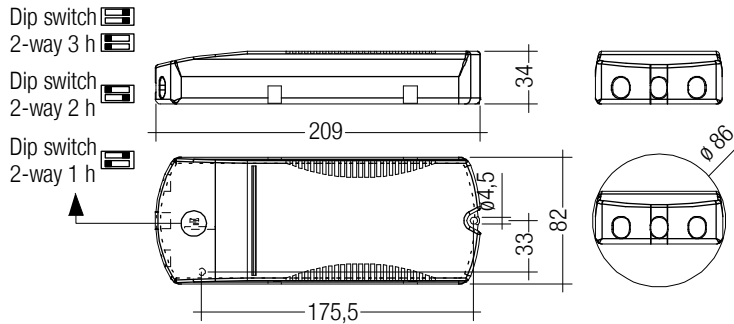

Note: LED driver supplied with duration dip switch (2-way) in 3 hours position. Duration dip switch and I-SELECT 2 PLUG must be set before battery and mains connection.

Ordering data

Type	Article number	Rated duration	Number of cells	Packaging, carton	Packaging, pallet	Weight per pc.
EM powerLED PRO DIM 103 SR NiCd 45W 50V	89800434	1/2/3 h	3	10 pc(s).	400 pc(s).	0.245 kg
EM powerLED PRO DIM 104 SR NiCd 45W 50V	89800416	1/2/3 h	4	10 pc(s).	400 pc(s).	0.245 kg
EM powerLED PRO DIM 103 SR NiMH 45W 50V	89800505	1/2/3 h	3	10 pc(s).	400 pc(s).	0.245 kg
EM powerLED PRO DIM 104 SR NiMH 45W 50V	89800509	1/2/3 h	4	10 pc(s).	400 pc(s).	0.245 kg

Technical data

Rated supply voltage	220 – 240 V
Mains frequency	50 / 60 Hz
Typ. λ (at 230 V, 50 Hz, normal operation)	0.95
Leakage current (PE)	< 0.5 mA
Overvoltage protection	320 V (for 48 h)
Max. open circuit voltage	60 V
Starting time	< 0.5 s from detection of emergency event
Output LF current ripple (< 120 Hz)	< 2 %
Output current tolerance	7 %
THD CF normal operation	< 10 %
Ambient temperature t_a at > 40 W	-5 ... +45 °C
Ambient temperature t_a at \leq 40 W	-5 ... +50 °C
Max. casing temperature t_c	75 °C
Dimensions L x W x H	209 x 82 x 34 mm
Mains voltage changeover threshold	According to EN 60598-2-22
Type of protection	IP20
Lifetime	up to 50,000 h
Guarantee (conditions at www.tridonic.com)	5 Year(s)

Approval marks



Standards

EN 55015, EN 61000-3-2, EN 61000-3-3, EN 61347-1, EN 61347-2-7, EN 61347-2-13, EN 61547, EN 62034, EN 62384, EN 62386-101, EN 62386-102, according to EN 60598-2-22, according to EN 50172

Specific technical data

Type	Number of battery cells	Output current	Min. output voltage	Max. output voltage	Min. output power	Max. output power	Input power (at 230 V, 50 Hz, full load), fast / trickle charge	Input current (at 230 V, 50 Hz, full load), fast / trickle charge	Efficiency (at 230 V, 50 Hz), fast / trickle charge	λ (at 230 V, 50 Hz, full load)		Ambient temperature <i>t_a</i>	<i>t_c</i> /ra for ≈ 50,000 h
										Fast charge	Trickle charge		
Normal operation													
EM powerLED PRO DIM 103 SR NiCd 45W 50V	-	300 mA	20 V	50 V	6.0 W	15.00 W	23.0 / 21.0 W	124 / 109 mA	71 / 75 %	0.81C	0.83C	-5 ... +50 °C	50/75 °C
EM powerLED PRO DIM 103 SR NiCd 45W 50V	-	325 mA	20 V	50 V	6.5 W	16.25 W	24.2 / 22.8 W	128 / 116 mA	72 / 73 %	0.82C	0.85C	-5 ... +50 °C	50/75 °C
EM powerLED PRO DIM 103 SR NiCd 45W 50V	-	350 mA	20 V	50 V	7.0 W	18.00 W	26.0 / 23.0 W	133 / 116 mA	74 / 79 %	0.84C	0.85C	-5 ... +50 °C	50/75 °C
EM powerLED PRO DIM 103 SR NiCd 45W 50V	-	375 mA	20 V	50 V	7.5 W	18.75 W	27.0 / 25.0 W	138 / 125 mA	74 / 77 %	0.85C	0.87C	-5 ... +50 °C	50/75 °C
EM powerLED PRO DIM 103 SR NiCd 45W 50V	-	400 mA	20 V	50 V	8.0 W	20.00 W	28.0 / 26.0 W	142 / 126 mA	76 / 81 %	0.86C	0.87C	-5 ... +50 °C	50/75 °C
EM powerLED PRO DIM 103 SR NiCd 45W 50V	-	425 mA	20 V	50 V	8.5 W	20.25 W	29.8 / 27.8 W	149 / 136 mA	75 / 78 %	0.87C	0.89C	-5 ... +50 °C	50/75 °C
EM powerLED PRO DIM 103 SR NiCd 45W 50V	-	450 mA	20 V	50 V	9.0 W	23.00 W	30.0 / 28.0 W	151 / 137 mA	78 / 82 %	0.87C	0.89C	-5 ... +50 °C	50/75 °C
EM powerLED PRO DIM 103 SR NiCd 45W 50V	-	475 mA	20 V	50 V	9.5 W	23.75 W	32.6 / 30.6 W	160 / 147 mA	77 / 79 %	0.87C	0.90C	-5 ... +50 °C	50/75 °C
EM powerLED PRO DIM 103 SR NiCd 45W 50V	-	500 mA	20 V	50 V	10.0 W	25.00 W	33.0 / 31.0 W	161 / 147 mA	80 / 83 %	0.89C	0.91C	-5 ... +50 °C	50/75 °C
EM powerLED PRO DIM 103 SR NiCd 45W 50V	-	525 mA	20 V	50 V	10.5 W	26.25 W	34.6 / 32.7 W	168 / 155 mA	80 / 82 %	0.90C	0.91C	-5 ... +50 °C	50/75 °C
EM powerLED PRO DIM 103 SR NiCd 45W 50V	-	550 mA	20 V	50 V	11.0 W	28.00 W	36.0 / 34.0 W	172 / 158 mA	81 / 84 %	0.90C	0.92C	-5 ... +50 °C	50/75 °C
EM powerLED PRO DIM 103 SR NiCd 45W 50V	-	575 mA	20 V	50 V	11.5 W	28.75 W	36.9 / 35.2 W	177 / 165 mA	82 / 83 %	0.91C	0.93C	-5 ... +50 °C	50/75 °C
EM powerLED PRO DIM 103 SR NiCd 45W 50V	-	600 mA	20 V	50 V	12.0 W	30.00 W	38.0 / 36.0 W	182 / 169 mA	82 / 85 %	0.92C	0.93C	-5 ... +50 °C	50/75 °C
EM powerLED PRO DIM 103 SR NiCd 45W 50V	-	625 mA	20 V	50 V	12.5 W	31.25 W	39.6 / 37.7 W	188 / 176 mA	82 / 84 %	0.92C	0.93C	-5 ... +50 °C	50/75 °C
EM powerLED PRO DIM 103 SR NiCd 45W 50V	-	650 mA	20 V	50 V	13.0 W	33.00 W	41.0 / 39.0 W	192 / 180 mA	83 / 86 %	0.92C	0.94C	-5 ... +50 °C	50/75 °C
EM powerLED PRO DIM 103 SR NiCd 45W 50V	-	675 mA	20 V	50 V	13.5 W	33.75 W	42.1 / 40.0 W	198 / 185 mA	83 / 86 %	0.93C	0.94C	-5 ... +50 °C	50/75 °C
EM powerLED PRO DIM 103 SR NiCd 45W 50V	-	700 mA	20 V	50 V	14.0 W	35.00 W	44.0 / 42.0 W	204 / 191 mA	84 / 86 %	0.93C	0.94C	-5 ... +50 °C	50/75 °C
EM powerLED PRO DIM 103 SR NiCd 45W 50V	-	725 mA	20 V	50 V	14.5 W	36.25 W	45.1 / 42.9 W	210 / 197 mA	83 / 86 %	0.93C	0.95	-5 ... +50 °C	50/75 °C
EM powerLED PRO DIM 103 SR NiCd 45W 50V	-	750 mA	20 V	50 V	15.0 W	38.00 W	46.0 / 44.0 W	215 / 203 mA	84 / 87 %	0.94C	0.95	-5 ... +50 °C	50/75 °C
EM powerLED PRO DIM 103 SR NiCd 45W 50V	-	775 mA	20 V	50 V	15.5 W	38.75 W	47.7 / 45.6 W	221 / 209 mA	84 / 86 %	0.94C	0.95	-5 ... +50 °C	50/75 °C
EM powerLED PRO DIM 103 SR NiCd 45W 50V	-	800 mA	20 V	50 V	16.0 W	40.00 W	49.0 / 47.0 W	225 / 212 mA	85 / 87 %	0.94C	0.95	-5 ... +50 °C	50/75 °C
EM powerLED PRO DIM 103 SR NiCd 45W 50V	-	825 mA	20 V	50 V	16.5 W	41.25 W	50.5 / 48.5 W	233 / 221 mA	84 / 86 %	0.95	0.96	-5 ... +45 °C	45/75 °C
EM powerLED PRO DIM 103 SR NiCd 45W 50V	-	850 mA	20 V	50 V	17.0 W	43.00 W	51.0 / 49.0 W	235 / 223 mA	86 / 88 %	0.95	0.96	-5 ... +45 °C	45/75 °C
EM powerLED PRO DIM 103 SR NiCd 45W 50V	-	875 mA	20 V	50 V	17.5 W	43.75 W	52.7 / 51.3 W	241 / 229 mA	86 / 86 %	0.95	0.96	-5 ... +45 °C	45/75 °C
EM powerLED PRO DIM 103 SR NiCd 45W 50V	-	900 mA	20 V	50 V	18.0 W	45.00 W	54.0 / 52.0 W	247 / 235 mA	86 / 88 %	0.95	0.96	-5 ... +45 °C	45/75 °C
EM powerLED PRO DIM 103 SR NiCd 45W 50V	-	925 mA	20 V	49 V	18.5 W	45.00 W	54.7 / 52.7 W	250 / 238 mA	85 / 86 %	0.95	0.96	-5 ... +45 °C	45/75 °C
EM powerLED PRO DIM 103 SR NiCd 45W 50V	-	950 mA	20 V	47 V	19.0 W	45.00 W	54.0 / 52.0 W	247 / 235 mA	86 / 88 %	0.95	0.96	-5 ... +45 °C	45/75 °C
EM powerLED PRO DIM 103 SR NiCd 45W 50V	-	975 mA	20 V	46 V	19.5 W	45.00 W	54.6 / 52.5 W	247 / 235 mA	85 / 87 %	0.95	0.96	-5 ... +45 °C	45/75 °C
EM powerLED PRO DIM 103 SR NiCd 45W 50V	-	1,000 mA	20 V	45 V	20.0 W	45.00 W	54.0 / 52.0 W	247 / 235 mA	86 / 88 %	0.95	0.96	-5 ... +45 °C	45/75 °C
EM powerLED PRO DIM 103 SR NiCd 45W 50V	-	1,025 mA	20 V	44 V	20.5 W	45.00 W	54.1 / 52.0 W	247 / 235 mA	86 / 88 %	0.95	0.96	-5 ... +45 °C	45/75 °C
EM powerLED PRO DIM 103 SR NiCd 45W 50V	-	1,050 mA	20 V	42 V	21.0 W	45.00 W	54.0 / 52.0 W	247 / 235 mA	86 / 88 %	0.95	0.96	-5 ... +45 °C	45/75 °C
EM powerLED PRO DIM 103 SR NiCd 45W 50V	-	1,075 mA	20 V	42 V	21.5 W	45.00 W	54.2 / 52.2 W	248 / 236 mA	86 / 87 %	0.95	0.96	-5 ... +45 °C	45/75 °C
EM powerLED PRO DIM 103 SR NiCd 45W 50V	-	1,100 mA	20 V	40 V	22.0 W	45.00 W	54.0 / 52.0 W	247 / 235 mA	87 / 88 %	0.95	0.96	-5 ... +45 °C	45/75 °C
EM powerLED PRO DIM 103 SR NiCd 45W 50V	-	1,125 mA	20 V	40 V	22.5 W	45.00 W	54.0 / 52.0 W	247 / 236 mA	86 / 88 %	0.95	0.96	-5 ... +45 °C	45/75 °C
EM powerLED PRO DIM 103 SR NiCd 45W 50V	-	1,150 mA	20 V	39 V	23.0 W	45.00 W	54.0 / 52.0 W	247 / 235 mA	87 / 88 %	0.95	0.96	-5 ... +45 °C	45/75 °C
EM powerLED PRO DIM 103 SR NiCd 45W 50V	-	1,175 mA	20 V	38 V	23.5 W	45.00 W	53.7 / 51.5 W	246 / 233 mA	86 / 89 %	0.95	0.96	-5 ... +45 °C	45/75 °C
EM powerLED PRO DIM 103 SR NiCd 45W 50V	-	1,200 mA	20 V	37 V	24.0 W	45.00 W	54.0 / 52.0 W	247 / 235 mA	87 / 88 %	0.95	0.96	-5 ... +45 °C	45/75 °C
EM powerLED PRO DIM 103 SR NiCd 45W 50V	-	1,225 mA	20 V	37 V	24.5 W	45.00 W	54.0 / 52.0 W	247 / 235 mA	86 / 88 %	0.95	0.96	-5 ... +45 °C	45/75 °C
EM powerLED PRO DIM 103 SR NiCd 45W 50V	-	1,250 mA	20 V	36 V	25.0 W	45.00 W	54.0 / 52.0 W	247 / 235 mA	87 / 88 %	0.95	0.96	-5 ... +45 °C	45/75 °C
EM powerLED PRO DIM 103 SR NiCd 45W 50V	-	1,275 mA	20 V	35 V	25.5 W	45.00 W	54.2 / 52.0 W	248 / 236 mA	86 / 88 %	0.95	0.96	-5 ... +45 °C	45/75 °C
EM powerLED PRO DIM 103 SR NiCd 45W 50V	-	1,300 mA	20 V	34 V	26.0 W	45.00 W	54.0 / 52.0 W	247 / 235 mA	87 / 88 %	0.95	0.96	-5 ... +45 °C	45/75 °C
EM powerLED PRO DIM 103 SR NiCd 45W 50V	-	1,325 mA	20 V	34 V	26.5 W	45.00 W	54.4 / 52.2 W	248 / 236 mA	85 / 87 %	0.95	0.96	-5 ... +45 °C	45/75 °C
EM powerLED PRO DIM 103 SR NiCd 45W 50V	-	1,350 mA	20 V	33 V	27.0 W	45.00 W	54.0 / 52.0 W	247 / 235 mA	87 / 88 %	0.95	0.96	-5 ... +45 °C	45/75 °C
EM powerLED PRO DIM 103 SR NiCd 45W 50V	-	1,375 mA	20 V	33 V	27.5 W	45.00 W	54.2 / 52.1 W	248 / 236 mA	86 / 87 %	0.95	0.96	-5 ... +45 °C	45/75 °C
EM powerLED PRO DIM 103 SR NiCd 45W 50V	-	1,400 mA	20 V	32 V	28.0 W	45.00 W	54.0 / 52.0 W	247 / 235 mA	87 / 90 %	0.95	0.96	-5 ... +45 °C	45/75 °C
EM powerLED PRO DIM 104 SR NiCd 45W 50V	-	300 mA	20 V	50 V	6.0 W	15.00 W	23.0 / 21.0 W	124 / 109 mA	71 / 75 %	0.81C	0.83C	-5 ... +50 °C	50/75 °C
EM powerLED PRO DIM 104 SR NiCd 45W 50V	-	325 mA	20 V	50 V	6.5 W	16.25 W	24.2 / 22.8 W	128 / 116 mA	72 / 73 %	0.82C	0.85C	-5 ... +50 °C	50/75 °C
EM powerLED PRO DIM 104 SR NiCd 45W 50V	-	350 mA	20 V	50 V	7.0 W	18.00 W	26.0 / 23.0 W	133 / 116 mA	74 / 79 %	0.84C	0.85C	-5 ... +50 °C	50/75 °C
EM powerLED PRO DIM 104 SR NiCd 45W 50V	-	375 mA	20 V	50 V	7.5 W	18.75 W	27.0 / 25.0 W	138 / 125 mA	74 / 77 %	0.85C	0.87C	-5 ... +50 °C	50/75 °C
EM powerLED PRO DIM 104 SR NiCd 45W 50V	-	400 mA	20 V	50 V	8.0 W	20.00 W	28.0 / 26.0 W	142 / 126 mA	76 / 81 %	0.86C	0.87C	-5 ... +50 °C	50/75 °C
EM powerLED PRO DIM 104 SR NiCd 45W 50V	-	425 mA	20 V	50 V	8.5 W	20.25 W	29.8 / 27.8 W	149 / 136 mA	75 / 78 %	0.87C	0.89C	-5 ... +50 °C	50/75 °C
EM powerLED PRO DIM 104 SR NiCd 45W 50V	-	450 mA	20 V	50 V	9.0 W	23.00 W	30.0 / 28.0 W	151 / 137 mA	78 / 82 %	0.87C	0.89C	-5 ... +50 °C	50/75 °C
EM powerLED PRO DIM 104 SR NiCd 45W 50V	-	475 mA	20 V	50 V	9.5 W	23.75 W	32.6 / 30.6 W	160 / 147 mA	77 / 79 %	0.87C	0.90C	-5 ... +50 °C	50/75 °C
EM powerLED PRO DIM 104 SR NiCd 45W 50V	-	500 mA	20 V	50 V	10.0 W	25.00 W	33.0 / 31.0 W	161 / 147 mA	80 / 83 %	0.89C	0.91C	-5 ... +50 °C	50/75 °C
EM powerLED PRO DIM 104 SR NiCd 45W 50V	-	525 mA	20 V	50 V	10.5 W	26.25 W	34.6 / 32.7 W	168 / 155 mA	80 / 82 %	0.90C	0.91C	-5 ... +50 °C	50/75 °C
EM powerLED PRO DIM 104 SR NiCd 45W 50V	-	550 mA	20 V	50 V	11.0 W	28.00 W	36.0 / 34.0 W	172 / 158 mA	81 / 84 %	0.90C	0.92C	-5 ... +50 °C	50/75 °C
EM powerLED PRO DIM 104 SR NiCd 45W 50V	-	575 mA	20 V	50 V	11.5 W	28.75 W	36.9 / 35.2 W	177 / 165 mA	82 / 83 %	0.91C	0.93C	-5 ... +50 °C	50/75 °C
EM powerLED PRO DIM 104 SR NiCd 45W 50V	-	600 mA	20 V	50 V	12.0 W	30.00 W	38.0 / 36.0 W	182 / 169 mA	82 / 85 %	0.92C	0.93C	-5 ... +50 °C	50/75 °C
EM powerLED PRO DIM 104 SR NiCd 45W 50V	-	625 mA	20 V	50 V	12.5 W	31.25 W	39.6 / 37.7 W	188 / 176 mA	82 / 84 %	0.92C	0.93C	-5 ... +50 °C	50/75 °C
EM powerLED PRO DIM 104 SR NiCd 45W 50V	-	650 mA	20 V	50 V	13.0 W	33.00 W	41.0 / 39.0 W	192 / 180 mA	83 / 86 %	0.92C	0.94C	-5 ... +50 °C	50/75 °C
EM powerLED PRO DIM 104 SR NiCd 45W 50V	-	675 mA	20 V	50 V	13.5 W	33.75 W	42.1 / 40.0 W	198 / 185 mA	83 / 86 %	0.93C	0.94C	-5 ... +50 °C	50/75 °C
EM powerLED PRO DIM 104 SR NiCd 45W 50V	-	700 mA	20 V	50 V	14.0 W	35.00 W	44.0 / 42.0 W	204 / 191 mA	84 / 86 %	0.93C	0.94C	-5 ... +50 °C	50/75 °C
EM powerLED PRO DIM 104 SR NiCd 45W 50V	-	725 mA	20 V	50 V	14.5 W	36.25 W	45.1 / 42.9 W	210 / 197 mA	83 / 86 %	0.93C	0.95	-5 ... +50 °C	50/75 °C
EM powerLED PRO DIM 104 SR NiCd 45W 50V	-	750 mA	20 V	50 V	15.0 W	38.00 W	46.0 / 44.0 W	215 / 203 mA	84 / 87 %	0.94C	0.95	-5 ... +50 °C	50/75 °C
EM powerLED PRO DIM 104 SR NiCd 45W 50V	-	775 mA	20 V	50 V	15.5 W	38.75 W	47.7 / 45.6 W	221 / 209 mA	84 / 86 %	0.94C	0.95	-5 ... +50 °C	50/75 °C

Emergency lighting units

EM powerLED

Type	Number of battery cells	Output current	Min. output voltage	Max. output voltage	Min. output power	Max. output power	Input power (at 230 V, 50 Hz, full load), fast / trickle charge	Input current (at 230 V, 50 Hz, full load), fast / trickle charge	Efficiency (at 230 V, 50 Hz), fast / trickle charge	λ (at 230 V, 50 Hz, full load)			tc/ta for ≥ 50,000 h
										Fast charge	Trickle charge	Ambient temperature ta	
EM powerLED PRO DIM 104 SR NiCd 45W 50V	-	800 mA	20 V	50 V	16.0 W	40.00 W	49.0 / 47.0 W	225 / 212 mA	85 / 87 %	0.94C	0.95	-5 ... +50 °C	50/75 °C
EM powerLED PRO DIM 104 SR NiCd 45W 50V	-	825 mA	20 V	50 V	16.5 W	41.25 W	50.5 / 48.5 W	233 / 221 mA	84 / 86 %	0.95	0.96	-5 ... +45 °C	45/75 °C
EM powerLED PRO DIM 104 SR NiCd 45W 50V	-	850 mA	20 V	50 V	17.0 W	43.00 W	51.0 / 49.0 W	235 / 223 mA	86 / 88 %	0.95	0.96	-5 ... +45 °C	45/75 °C
EM powerLED PRO DIM 104 SR NiCd 45W 50V	-	875 mA	20 V	50 V	17.5 W	43.75 W	52.7 / 51.3 W	241 / 229 mA	86 / 86 %	0.95	0.96	-5 ... +45 °C	45/75 °C
EM powerLED PRO DIM 104 SR NiCd 45W 50V	-	900 mA	20 V	50 V	18.0 W	45.00 W	54.0 / 52.0 W	247 / 235 mA	86 / 88 %	0.95	0.96	-5 ... +45 °C	45/75 °C
EM powerLED PRO DIM 104 SR NiCd 45W 50V	-	925 mA	20 V	49 V	18.5 W	45.00 W	54.7 / 52.7 W	250 / 238 mA	85 / 86 %	0.95	0.96	-5 ... +45 °C	45/75 °C
EM powerLED PRO DIM 104 SR NiCd 45W 50V	-	950 mA	20 V	47 V	19.0 W	45.00 W	54.0 / 52.0 W	247 / 235 mA	86 / 88 %	0.95	0.96	-5 ... +45 °C	45/75 °C
EM powerLED PRO DIM 104 SR NiCd 45W 50V	-	975 mA	20 V	46 V	19.5 W	45.00 W	54.6 / 52.5 W	247 / 235 mA	85 / 87 %	0.95	0.96	-5 ... +45 °C	45/75 °C
EM powerLED PRO DIM 104 SR NiCd 45W 50V	-	1,000 mA	20 V	45 V	20.0 W	45.00 W	54.0 / 52.0 W	247 / 235 mA	86 / 88 %	0.95	0.96	-5 ... +45 °C	45/75 °C
EM powerLED PRO DIM 104 SR NiCd 45W 50V	-	1,025 mA	20 V	44 V	20.5 W	45.00 W	54.1 / 52.0 W	247 / 235 mA	86 / 88 %	0.95	0.96	-5 ... +45 °C	45/75 °C
EM powerLED PRO DIM 104 SR NiCd 45W 50V	-	1,050 mA	20 V	42 V	21.0 W	45.00 W	54.0 / 52.0 W	247 / 235 mA	86 / 88 %	0.95	0.96	-5 ... +45 °C	45/75 °C
EM powerLED PRO DIM 104 SR NiCd 45W 50V	-	1,075 mA	20 V	42 V	21.5 W	45.00 W	54.2 / 52.2 W	248 / 236 mA	86 / 87 %	0.95	0.96	-5 ... +45 °C	45/75 °C
EM powerLED PRO DIM 104 SR NiCd 45W 50V	-	1,100 mA	20 V	40 V	22.0 W	45.00 W	54.0 / 52.0 W	247 / 235 mA	87 / 88 %	0.95	0.96	-5 ... +45 °C	45/75 °C
EM powerLED PRO DIM 104 SR NiCd 45W 50V	-	1,125 mA	20 V	40 V	22.5 W	45.00 W	54.0 / 52.0 W	247 / 236 mA	86 / 88 %	0.95	0.96	-5 ... +45 °C	45/75 °C
EM powerLED PRO DIM 104 SR NiCd 45W 50V	-	1,150 mA	20 V	39 V	23.0 W	45.00 W	54.0 / 52.0 W	247 / 235 mA	87 / 88 %	0.95	0.96	-5 ... +45 °C	45/75 °C
EM powerLED PRO DIM 104 SR NiCd 45W 50V	-	1,175 mA	20 V	38 V	23.5 W	45.00 W	53.7 / 51.5 W	246 / 233 mA	86 / 89 %	0.95	0.96	-5 ... +45 °C	45/75 °C
EM powerLED PRO DIM 104 SR NiCd 45W 50V	-	1,200 mA	20 V	37 V	24.0 W	45.00 W	54.0 / 52.0 W	247 / 235 mA	87 / 88 %	0.95	0.96	-5 ... +45 °C	45/75 °C
EM powerLED PRO DIM 104 SR NiCd 45W 50V	-	1,225 mA	20 V	37 V	24.5 W	45.00 W	54.0 / 52.0 W	247 / 235 mA	86 / 88 %	0.95	0.96	-5 ... +45 °C	45/75 °C
EM powerLED PRO DIM 104 SR NiCd 45W 50V	-	1,250 mA	20 V	36 V	25.0 W	45.00 W	54.0 / 52.0 W	247 / 235 mA	87 / 88 %	0.95	0.96	-5 ... +45 °C	45/75 °C
EM powerLED PRO DIM 104 SR NiCd 45W 50V	-	1,275 mA	20 V	35 V	25.5 W	45.00 W	54.2 / 52.0 W	248 / 236 mA	86 / 88 %	0.95	0.96	-5 ... +45 °C	45/75 °C
EM powerLED PRO DIM 104 SR NiCd 45W 50V	-	1,300 mA	20 V	34 V	26.0 W	45.00 W	54.0 / 52.0 W	247 / 235 mA	87 / 88 %	0.95	0.96	-5 ... +45 °C	45/75 °C
EM powerLED PRO DIM 104 SR NiCd 45W 50V	-	1,325 mA	20 V	34 V	26.5 W	45.00 W	54.4 / 52.2 W	248 / 236 mA	85 / 87 %	0.95	0.96	-5 ... +45 °C	45/75 °C
EM powerLED PRO DIM 104 SR NiCd 45W 50V	-	1,350 mA	20 V	33 V	27.0 W	45.00 W	54.0 / 52.0 W	247 / 235 mA	87 / 88 %	0.95	0.96	-5 ... +45 °C	45/75 °C
EM powerLED PRO DIM 104 SR NiCd 45W 50V	-	1,375 mA	20 V	33 V	27.5 W	45.00 W	54.2 / 52.1 W	248 / 236 mA	86 / 87 %	0.95	0.96	-5 ... +45 °C	45/75 °C
EM powerLED PRO DIM 104 SR NiCd 45W 50V	-	1,400 mA	20 V	32 V	28.0 W	45.00 W	54.0 / 52.0 W	247 / 235 mA	87 / 90 %	0.95	0.96	-5 ... +45 °C	45/75 °C
EM powerLED PRO DIM 103 SR NiMH 45W 50V	-	300 mA	20 V	50 V	6.0 W	15.00 W	23.0 / 21.0 W	124 / 109 mA	71 / 75 %	0.81C	0.83C	-5 ... +50 °C	50/75 °C
EM powerLED PRO DIM 103 SR NiMH 45W 50V	-	325 mA	20 V	50 V	6.5 W	16.25 W	24.2 / 22.8 W	128 / 116 mA	72 / 73 %	0.82C	0.85C	-5 ... +50 °C	50/75 °C
EM powerLED PRO DIM 103 SR NiMH 45W 50V	-	350 mA	20 V	50 V	7.0 W	18.00 W	26.0 / 23.0 W	133 / 116 mA	74 / 79 %	0.84C	0.85C	-5 ... +50 °C	50/75 °C
EM powerLED PRO DIM 103 SR NiMH 45W 50V	-	375 mA	20 V	50 V	7.5 W	18.75 W	27.0 / 25.0 W	138 / 125 mA	74 / 77 %	0.85C	0.87C	-5 ... +50 °C	50/75 °C
EM powerLED PRO DIM 103 SR NiMH 45W 50V	-	400 mA	20 V	50 V	8.0 W	20.00 W	28.0 / 26.0 W	142 / 126 mA	76 / 81 %	0.86C	0.87C	-5 ... +50 °C	50/75 °C
EM powerLED PRO DIM 103 SR NiMH 45W 50V	-	425 mA	20 V	50 V	8.5 W	20.25 W	29.8 / 27.8 W	149 / 136 mA	75 / 78 %	0.87C	0.89C	-5 ... +50 °C	50/75 °C
EM powerLED PRO DIM 103 SR NiMH 45W 50V	-	450 mA	20 V	50 V	9.0 W	23.00 W	30.0 / 28.0 W	151 / 137 mA	78 / 82 %	0.87C	0.89C	-5 ... +50 °C	50/75 °C
EM powerLED PRO DIM 103 SR NiMH 45W 50V	-	475 mA	20 V	50 V	9.5 W	23.75 W	32.6 / 30.6 W	160 / 147 mA	77 / 79 %	0.87C	0.90C	-5 ... +50 °C	50/75 °C
EM powerLED PRO DIM 103 SR NiMH 45W 50V	-	500 mA	20 V	50 V	10.0 W	25.00 W	33.0 / 31.0 W	161 / 147 mA	80 / 83 %	0.89C	0.91C	-5 ... +50 °C	50/75 °C
EM powerLED PRO DIM 103 SR NiMH 45W 50V	-	525 mA	20 V	50 V	10.5 W	26.25 W	34.6 / 32.7 W	168 / 155 mA	80 / 82 %	0.90C	0.91C	-5 ... +50 °C	50/75 °C
EM powerLED PRO DIM 103 SR NiMH 45W 50V	-	550 mA	20 V	50 V	11.0 W	28.00 W	36.0 / 34.0 W	172 / 158 mA	81 / 84 %	0.90C	0.92C	-5 ... +50 °C	50/75 °C
EM powerLED PRO DIM 103 SR NiMH 45W 50V	-	575 mA	20 V	50 V	11.5 W	28.75 W	36.9 / 35.2 W	177 / 165 mA	82 / 83 %	0.91C	0.93C	-5 ... +50 °C	50/75 °C
EM powerLED PRO DIM 103 SR NiMH 45W 50V	-	600 mA	20 V	50 V	12.0 W	30.00 W	38.0 / 36.0 W	182 / 169 mA	82 / 85 %	0.92C	0.93C	-5 ... +50 °C	50/75 °C
EM powerLED PRO DIM 103 SR NiMH 45W 50V	-	625 mA	20 V	50 V	12.5 W	31.25 W	39.6 / 37.7 W	188 / 176 mA	82 / 84 %	0.92C	0.93C	-5 ... +50 °C	50/75 °C
EM powerLED PRO DIM 103 SR NiMH 45W 50V	-	650 mA	20 V	50 V	13.0 W	33.00 W	41.0 / 39.0 W	192 / 180 mA	83 / 86 %	0.92C	0.94C	-5 ... +50 °C	50/75 °C
EM powerLED PRO DIM 103 SR NiMH 45W 50V	-	675 mA	20 V	50 V	13.5 W	33.75 W	42.1 / 40.0 W	198 / 185 mA	83 / 86 %	0.93C	0.94C	-5 ... +50 °C	50/75 °C
EM powerLED PRO DIM 103 SR NiMH 45W 50V	-	700 mA	20 V	50 V	14.0 W	35.00 W	44.0 / 42.0 W	204 / 191 mA	84 / 86 %	0.93C	0.94C	-5 ... +50 °C	50/75 °C
EM powerLED PRO DIM 103 SR NiMH 45W 50V	-	725 mA	20 V	50 V	14.5 W	36.25 W	45.1 / 42.9 W	210 / 197 mA	83 / 86 %	0.93C	0.95	-5 ... +50 °C	50/75 °C
EM powerLED PRO DIM 103 SR NiMH 45W 50V	-	750 mA	20 V	50 V	15.0 W	38.00 W	46.0 / 44.0 W	215 / 203 mA	84 / 87 %	0.94C	0.95	-5 ... +50 °C	50/75 °C
EM powerLED PRO DIM 103 SR NiMH 45W 50V	-	775 mA	20 V	50 V	15.5 W	38.75 W	47.7 / 45.6 W	221 / 209 mA	84 / 86 %	0.94C	0.95	-5 ... +50 °C	50/75 °C
EM powerLED PRO DIM 103 SR NiMH 45W 50V	-	800 mA	20 V	50 V	16.0 W	40.00 W	49.0 / 47.0 W	225 / 212 mA	85 / 87 %	0.94C	0.95	-5 ... +50 °C	50/75 °C
EM powerLED PRO DIM 103 SR NiMH 45W 50V	-	825 mA	20 V	50 V	16.5 W	41.25 W	50.5 / 48.5 W	233 / 221 mA	84 / 86 %	0.95	0.96	-5 ... +45 °C	45/75 °C
EM powerLED PRO DIM 103 SR NiMH 45W 50V	-	850 mA	20 V	50 V	17.0 W	43.00 W	51.0 / 49.0 W	235 / 223 mA	86 / 88 %	0.95	0.96	-5 ... +45 °C	45/75 °C
EM powerLED PRO DIM 103 SR NiMH 45W 50V	-	875 mA	20 V	50 V	17.5 W	43.75 W	52.7 / 51.3 W	241 / 229 mA	86 / 86 %	0.95	0.96	-5 ... +45 °C	45/75 °C
EM powerLED PRO DIM 103 SR NiMH 45W 50V	-	900 mA	20 V	50 V	18.0 W	45.00 W	54.0 / 52.0 W	247 / 235 mA	86 / 88 %	0.95	0.96	-5 ... +45 °C	45/75 °C
EM powerLED PRO DIM 103 SR NiMH 45W 50V	-	925 mA	20 V	49 V	18.5 W	45.00 W	54.7 / 52.7 W	250 / 238 mA	85 / 86 %	0.95	0.96	-5 ... +45 °C	45/75 °C
EM powerLED PRO DIM 103 SR NiMH 45W 50V	-	950 mA	20 V	47 V	19.0 W	45.00 W	54.0 / 52.0 W	247 / 235 mA	86 / 88 %	0.95	0.96	-5 ... +45 °C	45/75 °C
EM powerLED PRO DIM 103 SR NiMH 45W 50V	-	975 mA	20 V	46 V	19.5 W	45.00 W	54.6 / 52.5 W	247 / 235 mA	85 / 87 %	0.95	0.96	-5 ... +45 °C	45/75 °C
EM powerLED PRO DIM 103 SR NiMH 45W 50V	-	1,000 mA	20 V	45 V	20.0 W	45.00 W	54.0 / 52.0 W	247 / 235 mA	86 / 88 %	0.95	0.96	-5 ... +45 °C	45/75 °C
EM powerLED PRO DIM 103 SR NiMH 45W 50V	-	1,025 mA	20 V	44 V	20.5 W	45.00 W	54.1 / 52.0 W	247 / 235 mA	86 / 88 %	0.95	0.96	-5 ... +45 °C	45/75 °C
EM powerLED PRO DIM 103 SR NiMH 45W 50V	-	1,050 mA	20 V	42 V	21.0 W	45.00 W	54.0 / 52.0 W	247 / 235 mA	86 / 88 %	0.95	0.96	-5 ... +45 °C	45/75 °C
EM powerLED PRO DIM 103 SR NiMH 45W 50V	-	1,075 mA	20 V	42 V	21.5 W	45.00 W	54.2 / 52.2 W	248 / 236 mA	86 / 87 %	0.95	0.96	-5 ... +45 °C	45/75 °C
EM powerLED PRO DIM 103 SR NiMH 45W 50V	-	1,100 mA	20 V	40 V	22.0 W	45.00 W	54.0 / 52.0 W	247 / 235 mA	87 / 88 %	0.95	0.96	-5 ... +45 °C	45/75 °C
EM powerLED PRO DIM 103 SR NiMH 45W 50V	-	1,125 mA	20 V	40 V	22.5 W	45.00 W	54.0 / 52.0 W	247 / 236 mA	86 / 88 %	0.95	0.96	-5 ... +45 °C	45/75 °C
EM powerLED PRO DIM 103 SR NiMH 45W 50V	-	1,150 mA	20 V	39 V	23.0 W	45.00 W	54.0 / 52.0 W	247 / 235 mA	87 / 88 %	0.95	0.96	-5 ... +45 °C	45/75 °C
EM powerLED PRO DIM 103 SR NiMH 45W 50V	-	1,175 mA	20 V	38 V	23.5 W	45.00 W	53.7 / 51.5 W	246 / 233 mA	86 / 89 %	0.95	0.96	-5 ... +45 °C	45/75 °C
EM powerLED PRO DIM 103 SR NiMH 45W 50V	-	1,200 mA	20 V	37 V	24.0 W	45.00 W	54.0 / 52.0 W	247 / 235 mA	87 / 88 %	0.95	0.96	-5 ... +45 °C	45/75 °C
EM powerLED PRO DIM 103 SR NiMH 45W 50V	-	1,225 mA	20 V	37 V	24.5 W	45.00 W	54.0 / 52.0 W	247 / 235 mA	86 / 88 %	0.95	0.96	-5 ... +45 °C	45/75 °C
EM powerLED PRO DIM 103 SR NiMH 45W 50V	-	1,250 mA	20 V	36 V	25.0 W	45.00 W	54.0 / 52.0 W	247 / 235 mA	87 / 88 %	0.95	0.96	-5 ... +45 °C	45/75 °C
EM powerLED PRO DIM 103 SR NiMH 45W 50V	-	1,275 mA	20 V	35 V	25.5 W	45.00 W	54.2 / 52.0 W	248 / 236 mA	86 / 88 %	0.95	0.96	-5 ... +45 °C	45/75 °C
EM powerLED PRO DIM 103 SR NiMH 45W 50V	-	1,300 mA	20 V	34 V	26.0 W	45.00 W	54.0 / 52.0 W	247 / 235 mA	87 / 88 %	0.95	0.96	-5 ... +45 °C	45/75 °C
EM powerLED PRO DIM 103 SR NiMH 45W 50V	-	1,325 mA	20 V	34 V	26.5 W	45.00 W	54.4 / 52.2 W	248 / 236 mA	85 / 87 %	0.95	0.96	-5 ... +45 °C	45/75 °C

Type	Number of battery cells	Output current	Min. output voltage	Max. output voltage	Min. output power	Max. output power	Input power (at 230 V, 50 Hz, full load), fast / trickle charge	Input current (at 230 V, 50 Hz, full load), fast / trickle charge	Efficiency (at 230 V, 50 Hz), fast / trickle charge	λ (at 230 V, 50 Hz, full load)			tc/ta for ≥ 50,000 h
										Fast charge	Trickle charge	Ambient temperature ta	
EM powerLED PRO DIM 103 SR NiMH 45W 50V	-	1,350 mA	20 V	33 V	27.0 W	45.00 W	54.0 / 52.0 W	247 / 235 mA	87 / 88 %	0.95	0.96	-5 ... +45 °C	45/75 °C
EM powerLED PRO DIM 103 SR NiMH 45W 50V	-	1,375 mA	20 V	33 V	27.5 W	45.00 W	54.2 / 52.1 W	248 / 236 mA	86 / 87 %	0.95	0.96	-5 ... +45 °C	45/75 °C
EM powerLED PRO DIM 103 SR NiMH 45W 50V	-	1,400 mA	20 V	32 V	28.0 W	45.00 W	54.0 / 52.0 W	247 / 235 mA	87 / 90 %	0.95	0.96	-5 ... +45 °C	45/75 °C
EM powerLED PRO DIM 104 SR NiMH 45W 50V	-	300 mA	20 V	50 V	6.0 W	15.00 W	23.0 / 21.0 W	124 / 109 mA	71 / 75 %	0.81C	0.83C	-5 ... +50 °C	50/75 °C
EM powerLED PRO DIM 104 SR NiMH 45W 50V	-	325 mA	20 V	50 V	6.5 W	16.25 W	24.2 / 22.8 W	128 / 116 mA	72 / 73 %	0.82C	0.85C	-5 ... +50 °C	50/75 °C
EM powerLED PRO DIM 104 SR NiMH 45W 50V	-	350 mA	20 V	50 V	7.0 W	18.00 W	26.0 / 23.0 W	133 / 116 mA	74 / 79 %	0.84C	0.85C	-5 ... +50 °C	50/75 °C
EM powerLED PRO DIM 104 SR NiMH 45W 50V	-	375 mA	20 V	50 V	7.5 W	18.75 W	27.0 / 25.0 W	138 / 125 mA	74 / 77 %	0.85C	0.87C	-5 ... +50 °C	50/75 °C
EM powerLED PRO DIM 104 SR NiMH 45W 50V	-	400 mA	20 V	50 V	8.0 W	20.00 W	28.0 / 26.0 W	142 / 126 mA	76 / 81 %	0.86C	0.87C	-5 ... +50 °C	50/75 °C
EM powerLED PRO DIM 104 SR NiMH 45W 50V	-	425 mA	20 V	50 V	8.5 W	20.25 W	29.8 / 27.8 W	149 / 136 mA	75 / 78 %	0.87C	0.89C	-5 ... +50 °C	50/75 °C
EM powerLED PRO DIM 104 SR NiMH 45W 50V	-	450 mA	20 V	50 V	9.0 W	23.00 W	30.0 / 28.0 W	151 / 137 mA	78 / 82 %	0.87C	0.89C	-5 ... +50 °C	50/75 °C
EM powerLED PRO DIM 104 SR NiMH 45W 50V	-	475 mA	20 V	50 V	9.5 W	23.75 W	32.6 / 30.6 W	160 / 147 mA	77 / 79 %	0.87C	0.90C	-5 ... +50 °C	50/75 °C
EM powerLED PRO DIM 104 SR NiMH 45W 50V	-	500 mA	20 V	50 V	10.0 W	25.00 W	33.0 / 31.0 W	161 / 147 mA	80 / 83 %	0.89C	0.91C	-5 ... +50 °C	50/75 °C
EM powerLED PRO DIM 104 SR NiMH 45W 50V	-	525 mA	20 V	50 V	10.5 W	26.25 W	34.6 / 32.7 W	168 / 155 mA	80 / 82 %	0.90C	0.91C	-5 ... +50 °C	50/75 °C
EM powerLED PRO DIM 104 SR NiMH 45W 50V	-	550 mA	20 V	50 V	11.0 W	28.00 W	36.0 / 34.0 W	172 / 158 mA	81 / 84 %	0.90C	0.92C	-5 ... +50 °C	50/75 °C
EM powerLED PRO DIM 104 SR NiMH 45W 50V	-	575 mA	20 V	50 V	11.5 W	28.75 W	36.9 / 35.2 W	177 / 165 mA	82 / 83 %	0.91C	0.93C	-5 ... +50 °C	50/75 °C
EM powerLED PRO DIM 104 SR NiMH 45W 50V	-	600 mA	20 V	50 V	12.0 W	30.00 W	38.0 / 36.0 W	182 / 169 mA	82 / 85 %	0.92C	0.93C	-5 ... +50 °C	50/75 °C
EM powerLED PRO DIM 104 SR NiMH 45W 50V	-	625 mA	20 V	50 V	12.5 W	31.25 W	39.6 / 37.7 W	188 / 176 mA	82 / 84 %	0.92C	0.93C	-5 ... +50 °C	50/75 °C
EM powerLED PRO DIM 104 SR NiMH 45W 50V	-	650 mA	20 V	50 V	13.0 W	33.00 W	41.0 / 39.0 W	192 / 180 mA	83 / 86 %	0.92C	0.94C	-5 ... +50 °C	50/75 °C
EM powerLED PRO DIM 104 SR NiMH 45W 50V	-	675 mA	20 V	50 V	13.5 W	33.75 W	42.1 / 40.0 W	198 / 185 mA	83 / 86 %	0.93C	0.94C	-5 ... +50 °C	50/75 °C
EM powerLED PRO DIM 104 SR NiMH 45W 50V	-	700 mA	20 V	50 V	14.0 W	35.00 W	44.0 / 42.0 W	204 / 191 mA	84 / 86 %	0.93C	0.94C	-5 ... +50 °C	50/75 °C
EM powerLED PRO DIM 104 SR NiMH 45W 50V	-	725 mA	20 V	50 V	14.5 W	36.25 W	45.1 / 42.9 W	210 / 197 mA	83 / 86 %	0.93C	0.95	-5 ... +50 °C	50/75 °C
EM powerLED PRO DIM 104 SR NiMH 45W 50V	-	750 mA	20 V	50 V	15.0 W	38.00 W	46.0 / 44.0 W	215 / 203 mA	84 / 87 %	0.94C	0.95	-5 ... +50 °C	50/75 °C
EM powerLED PRO DIM 104 SR NiMH 45W 50V	-	775 mA	20 V	50 V	15.5 W	38.75 W	47.7 / 45.6 W	221 / 209 mA	84 / 86 %	0.94C	0.95	-5 ... +50 °C	50/75 °C
EM powerLED PRO DIM 104 SR NiMH 45W 50V	-	800 mA	20 V	50 V	16.0 W	40.00 W	49.0 / 47.0 W	225 / 212 mA	85 / 87 %	0.94C	0.95	-5 ... +50 °C	50/75 °C
EM powerLED PRO DIM 104 SR NiMH 45W 50V	-	825 mA	20 V	50 V	16.5 W	41.25 W	50.5 / 48.5 W	233 / 221 mA	84 / 86 %	0.95	0.96	-5 ... +45 °C	45/75 °C
EM powerLED PRO DIM 104 SR NiMH 45W 50V	-	850 mA	20 V	50 V	17.0 W	43.00 W	51.0 / 49.0 W	235 / 223 mA	86 / 88 %	0.95	0.96	-5 ... +45 °C	45/75 °C
EM powerLED PRO DIM 104 SR NiMH 45W 50V	-	875 mA	20 V	50 V	17.5 W	43.75 W	52.7 / 51.3 W	241 / 229 mA	86 / 86 %	0.95	0.96	-5 ... +45 °C	45/75 °C
EM powerLED PRO DIM 104 SR NiMH 45W 50V	-	900 mA	20 V	50 V	18.0 W	45.00 W	54.0 / 52.0 W	247 / 235 mA	86 / 88 %	0.95	0.96	-5 ... +45 °C	45/75 °C
EM powerLED PRO DIM 104 SR NiMH 45W 50V	-	925 mA	20 V	49 V	18.5 W	45.00 W	54.7 / 52.7 W	250 / 238 mA	85 / 86 %	0.95	0.96	-5 ... +45 °C	45/75 °C
EM powerLED PRO DIM 104 SR NiMH 45W 50V	-	950 mA	20 V	47 V	19.0 W	45.00 W	54.0 / 52.0 W	247 / 235 mA	86 / 88 %	0.95	0.96	-5 ... +45 °C	45/75 °C
EM powerLED PRO DIM 104 SR NiMH 45W 50V	-	975 mA	20 V	46 V	19.5 W	45.00 W	54.6 / 52.5 W	247 / 235 mA	85 / 87 %	0.95	0.96	-5 ... +45 °C	45/75 °C
EM powerLED PRO DIM 104 SR NiMH 45W 50V	-	1,000 mA	20 V	45 V	20.0 W	45.00 W	54.0 / 52.0 W	247 / 235 mA	86 / 88 %	0.95	0.96	-5 ... +45 °C	45/75 °C
EM powerLED PRO DIM 104 SR NiMH 45W 50V	-	1,025 mA	20 V	44 V	20.5 W	45.00 W	54.1 / 52.0 W	247 / 235 mA	86 / 88 %	0.95	0.96	-5 ... +45 °C	45/75 °C
EM powerLED PRO DIM 104 SR NiMH 45W 50V	-	1,050 mA	20 V	42 V	21.0 W	45.00 W	54.0 / 52.0 W	247 / 235 mA	86 / 88 %	0.95	0.96	-5 ... +45 °C	45/75 °C
EM powerLED PRO DIM 104 SR NiMH 45W 50V	-	1,075 mA	20 V	42 V	21.5 W	45.00 W	54.2 / 52.2 W	248 / 236 mA	86 / 87 %	0.95	0.96	-5 ... +45 °C	45/75 °C
EM powerLED PRO DIM 104 SR NiMH 45W 50V	-	1,100 mA	20 V	40 V	22.0 W	45.00 W	54.0 / 52.0 W	247 / 235 mA	87 / 88 %	0.95	0.96	-5 ... +45 °C	45/75 °C
EM powerLED PRO DIM 104 SR NiMH 45W 50V	-	1,125 mA	20 V	40 V	22.5 W	45.00 W	54.0 / 52.0 W	247 / 236 mA	86 / 88 %	0.95	0.96	-5 ... +45 °C	45/75 °C
EM powerLED PRO DIM 104 SR NiMH 45W 50V	-	1,150 mA	20 V	39 V	23.0 W	45.00 W	54.0 / 52.0 W	247 / 235 mA	87 / 88 %	0.95	0.96	-5 ... +45 °C	45/75 °C
EM powerLED PRO DIM 104 SR NiMH 45W 50V	-	1,175 mA	20 V	38 V	23.5 W	45.00 W	53.7 / 51.5 W	246 / 233 mA	86 / 89 %	0.95	0.96	-5 ... +45 °C	45/75 °C
EM powerLED PRO DIM 104 SR NiMH 45W 50V	-	1,200 mA	20 V	37 V	24.0 W	45.00 W	54.0 / 52.0 W	247 / 235 mA	87 / 88 %	0.95	0.96	-5 ... +45 °C	45/75 °C
EM powerLED PRO DIM 104 SR NiMH 45W 50V	-	1,225 mA	20 V	37 V	24.5 W	45.00 W	54.0 / 52.0 W	247 / 235 mA	86 / 88 %	0.95	0.96	-5 ... +45 °C	45/75 °C
EM powerLED PRO DIM 104 SR NiMH 45W 50V	-	1,250 mA	20 V	36 V	25.0 W	45.00 W	54.0 / 52.0 W	247 / 235 mA	87 / 88 %	0.95	0.96	-5 ... +45 °C	45/75 °C
EM powerLED PRO DIM 104 SR NiMH 45W 50V	-	1,275 mA	20 V	35 V	25.5 W	45.00 W	54.2 / 52.0 W	248 / 236 mA	86 / 88 %	0.95	0.96	-5 ... +45 °C	45/75 °C
EM powerLED PRO DIM 104 SR NiMH 45W 50V	-	1,300 mA	20 V	34 V	26.0 W	45.00 W	54.0 / 52.0 W	247 / 235 mA	87 / 88 %	0.95	0.96	-5 ... +45 °C	45/75 °C
EM powerLED PRO DIM 104 SR NiMH 45W 50V	-	1,325 mA	20 V	34 V	26.5 W	45.00 W	54.4 / 52.2 W	248 / 236 mA	85 / 87 %	0.95	0.96	-5 ... +45 °C	45/75 °C
EM powerLED PRO DIM 104 SR NiMH 45W 50V	-	1,350 mA	20 V	33 V	27.0 W	45.00 W	54.0 / 52.0 W	247 / 235 mA	87 / 88 %	0.95	0.96	-5 ... +45 °C	45/75 °C
EM powerLED PRO DIM 104 SR NiMH 45W 50V	-	1,375 mA	20 V	33 V	27.5 W	45.00 W	54.2 / 52.1 W	248 / 236 mA	86 / 87 %	0.95	0.96	-5 ... +45 °C	45/75 °C
EM powerLED PRO DIM 104 SR NiMH 45W 50V	-	1,400 mA	20 V	32 V	28.0 W	45.00 W	54.0 / 52.0 W	247 / 235 mA	87 / 90 %	0.95	0.96	-5 ... +45 °C	45/75 °C
Emergency operation													
EM powerLED PRO DIM 103 SR NiCd 45W 50V	3	-	15 V	50 V	2.1 W	2.75 W	-	-	-	-	-	-	-
EM powerLED PRO DIM 103 SR NiCd 45W 50V	4	-	15 V	50 V	2.7 W	3.50 W	-	-	-	-	-	-	-
EM powerLED PRO DIM 104 SR NiCd 45W 50V	3	-	15 V	50 V	2.1 W	2.75 W	-	-	-	-	-	-	-
EM powerLED PRO DIM 104 SR NiCd 45W 50V	4	-	15 V	50 V	2.7 W	3.50 W	-	-	-	-	-	-	-
EM powerLED PRO DIM 103 SR NiMH 45W 50V	3	-	15 V	50 V	2.1 W	2.75 W	-	-	-	-	-	-	-
EM powerLED PRO DIM 103 SR NiMH 45W 50V	4	-	15 V	50 V	2.7 W	3.50 W	-	-	-	-	-	-	-
EM powerLED PRO DIM 104 SR NiMH 45W 50V	3	-	15 V	50 V	2.1 W	2.75 W	-	-	-	-	-	-	-
EM powerLED PRO DIM 104 SR NiMH 45W 50V	4	-	15 V	50 V	2.7 W	3.50 W	-	-	-	-	-	-	-

Test switch EM2

Accessory



Product description

- _ For connection to the emergency lighting unit
- _ For checking the device function
- _ Dielectric strength: 1,500 V AC for 60 seconds

Website

<http://www.tridonic.com/89805277>



Ordering data

Type	Article number	Packaging, bag	Packaging, carton	Weight per pc.
Test switch EM 2	89805277	25 pc(s).	600 pc(s).	0.009 kg

Approval marks

RoHS

Status indication bi-colour LED EM

Accessory



Product description

- _ Two-colour status display LED
- _ Green: system OK, red: fault

Website

<http://www.tridonic.com/89899720>



Ordering data

Type	Article number	Packaging, bag	Packaging, carton	Weight per pc.
LED EM bi-colour	89899720	25 pc(s).	200 pc(s).	0.017 kg
LED EM bi-colour, high brightness	89899753	25 pc(s).	200 pc(s).	0.013 kg

Approval marks

RoHS

I-SELECT 2 PLUG PRE / EXC

Accessory

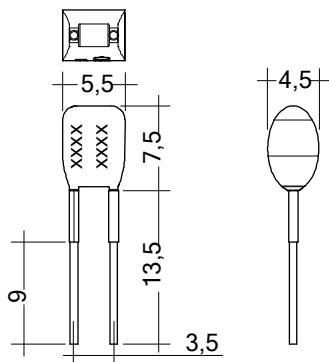
**Product description**

- _ Ready-for-use resistor to set output current value
- _ Compatible with LED driver featuring I-select 2 interface; not compatible with I-SELECT (generation 1)
- _ Resistor is base insulated
- _ Resistor power 0.25 W
- _ Current tolerance $\pm 2\%$ additional to output current tolerance
- _ Compatible with LED driver series PRE and EXC

Example of calculation

- _ $R [k\Omega] = 5 V / I_{out} [mA] \times 1000$
- _ E96 resistor value used
- _ Resistor value tolerance $\leq 1\%$; resistor power $\geq 0.1 W$; base insulation necessary
- _ When using a resistor value beyond the specified range, the output current will automatically be set to the minimum value (resistor value too big), respectively to the maximum value (resistor value too small)

Website

<http://www.tridonic.com/28001101>



Ordering data

Type	Article number	Colour	Marking	Current	Resistor value	Packaging, bag	Weight per pc.
I-SELECT 2 PLUG 125MA BL	28001101	Blue	0125 mA	125 mA	40.20 kΩ	10 pc(s).	0.001 kg
I-SELECT 2 PLUG 300MA BL	28001108	Blue	0300 mA	300 mA	16.50 kΩ	10 pc(s).	0.001 kg
I-SELECT 2 PLUG 325MA BL	28001109	Blue	0325 mA	325 mA	15.40 kΩ	10 pc(s).	0.001 kg
I-SELECT 2 PLUG 350MA BL	28001110	Blue	0350 mA	350 mA	14.30 kΩ	10 pc(s).	0.001 kg
I-SELECT 2 PLUG 375MA BL	28001111	Blue	0375 mA	375 mA	13.30 kΩ	10 pc(s).	0.001 kg
I-SELECT 2 PLUG 400MA BL	28001112	Blue	0400 mA	400 mA	12.40 kΩ	10 pc(s).	0.001 kg
I-SELECT 2 PLUG 425MA BL	28001251	Blue	0425 mA	425 mA	11.80 kΩ	10 pc(s).	0.001 kg
I-SELECT 2 PLUG 450MA BL	28001113	Blue	0450 mA	450 mA	11.00 kΩ	10 pc(s).	0.001 kg
I-SELECT 2 PLUG 475MA BL	28001252	Blue	0475 mA	475 mA	10.50 kΩ	10 pc(s).	0.001 kg
I-SELECT 2 PLUG 500MA BL	28001114	Blue	0500 mA	500 mA	10.00 kΩ	10 pc(s).	0.001 kg
I-SELECT 2 PLUG 550MA BL	28001115	Blue	0550 mA	550 mA	9.09 kΩ	10 pc(s).	0.001 kg
I-SELECT 2 PLUG 600MA BL	28001116	Blue	0600 mA	600 mA	8.25 kΩ	10 pc(s).	0.001 kg
I-SELECT 2 PLUG 650MA BL	28001117	Blue	0650 mA	650 mA	7.68 kΩ	10 pc(s).	0.001 kg
I-SELECT 2 PLUG 700MA BL	28001118	Blue	0700 mA	700 mA	7.15 kΩ	10 pc(s).	0.001 kg
I-SELECT 2 PLUG 750MA BL	28001119	Blue	0750 mA	750 mA	6.65 kΩ	10 pc(s).	0.001 kg
I-SELECT 2 PLUG 800MA BL	28001120	Blue	0800 mA	800 mA	6.19 kΩ	10 pc(s).	0.001 kg
I-SELECT 2 PLUG 850MA BL	28001121	Blue	0850 mA	850 mA	5.90 kΩ	10 pc(s).	0.001 kg
I-SELECT 2 PLUG 900MA BL	28001122	Blue	0900 mA	900 mA	5.62 kΩ	10 pc(s).	0.001 kg
I-SELECT 2 PLUG 950MA BL	28001123	Blue	0950 mA	950 mA	5.23 kΩ	10 pc(s).	0.001 kg
I-SELECT 2 PLUG 1000MA BL	28001124	Blue	1000 mA	1,000 mA	4.99 kΩ	10 pc(s).	0.001 kg
I-SELECT 2 PLUG 1050MA BL	28001125	Blue	1050 mA	1,050 mA	4.75 kΩ	10 pc(s).	0.001 kg
I-SELECT 2 PLUG 1100MA BL	28001126	Blue	1100 mA	1,100 mA	4.53 kΩ	10 pc(s).	0.001 kg
I-SELECT 2 PLUG 1150MA BL	28001127	Blue	1150 mA	1,150 mA	4.32 kΩ	10 pc(s).	0.001 kg
I-SELECT 2 PLUG 1200MA BL	28001128	Blue	1200 mA	1,200 mA	4.12 kΩ	10 pc(s).	0.001 kg
I-SELECT 2 PLUG 1250MA BL	28001129	Blue	1250 mA	1,250 mA	4.02 kΩ	10 pc(s).	0.001 kg
I-SELECT 2 PLUG 1300MA BL	28001130	Blue	1300 mA	1,300 mA	3.83 kΩ	10 pc(s).	0.001 kg
I-SELECT 2 PLUG 1350MA BL	28001131	Blue	1350 mA	1,350 mA	3.74 kΩ	10 pc(s).	0.001 kg
I-SELECT 2 PLUG 1400MA BL	28001132	Blue	1400 mA	1,400 mA	3.57 kΩ	10 pc(s).	0.001 kg
I-SELECT 2 PLUG MAX BL	28001099	Blue	MAX	MAX	0.00 kΩ	10 pc(s).	0.001 kg

NiMH Battery pack 2.2 – 4.0 Ah

Accessory



Product description

- _ High-temperature NiMH battery pack for use with emergency lighting units
- _ 4 year design life
- _ 2 years guarantee (conditions at <https://www.tridonic.com/manufacturer-guarantee-conditions>)

Properties

- _ Constant high-temperature operation
- _ Temperature depending on the used emergency lighting unit (refer to respective emergency control gear data sheet)
- _ Good charging properties at high temperature
- _ High energy maintenance of the charged battery
- _ Certified quality manufacturer
- _ Casing material made of polycarbonate
- _ 1.0 mm² stranded wire
- _ Suitable for emergency lighting equipment as per IEC 60598-2-22

Website

<http://www.tridonic.com/28001898>



Emergency lighting units

EM powerLED

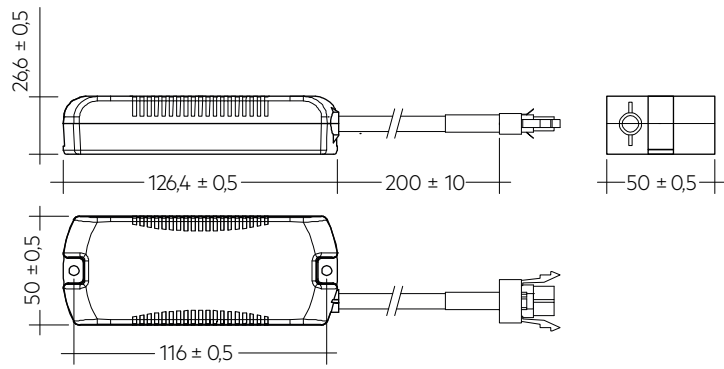

Ordering data

Type	Article number	Capacity	Packaging, carton	Packaging, outer box	Weight per pc.
2.2 Ah battery pack					
PACK-NiMH 2.2Ah 3 CON	28001898	2.2 Ah	5 pc(s).	25 pc(s).	0.258 kg
PACK-NiMH 2.2Ah 4 CON	28001899	2.2 Ah	5 pc(s).	25 pc(s).	0.352 kg
4.0 Ah battery pack					
PACK-NiMH 4Ah 3 CON	28001896	4.0 Ah	5 pc(s).	25 pc(s).	0.300 kg
PACK-NiMH 4Ah 4 CON	28001897	4.0 Ah	5 pc(s).	25 pc(s).	0.440 kg

ACD EM LED INDICATOR HOLDER

Accessory

Product description

- _ Holder for indicator LED in emergency operation
- _ Glow-wire test with a temperature of 850 °C passed

**Website**

<http://www.tridonic.com/28002189>

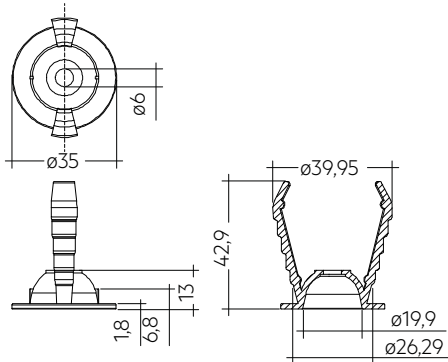
**Ordering data**

Type	Article number	Colour	Packaging, carton	Weight per pc.
ACD EM LED INDICATOR HOLDER	28002189	White	120 pc(s).	0.006 kg

NiCd Battery pack 1.8 – 4.5 Ah

Accessory

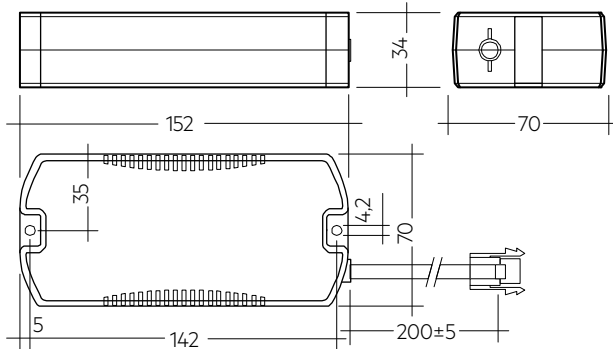

Product description

- _ High-temperature NiCd battery pack for use with emergency lighting units
- _ Please note that due to EU law, this article is available for purchasing only outside of the European Union.
- _ 4 year design life
- _ 2 years guarantee (Conditions at <https://www.tridonic.com/manufacture-guarantee-conditions>)

Properties

- _ Constant high-temperature operation
- _ Temperature depending on the used emergency lighting unit (refer to respective emergency control gear data sheet)
- _ Good charging properties at high temperature
- _ High energy maintenance of the charged battery
- _ Certified quality manufacturer
- _ Casing material made of polycarbonate
- _ 1.0 m integrated double-insulated cable
- _ 1.0 mm² solid wire, pre-stripped
- _ Suitable for emergency lighting equipment as per IEC 60598-2-22

Website

<http://www.tridonic.com/28001221>



Ordering data

Type	Article number	Packaging, carton	Packaging, outer box	Weight per pc.
Battery pack 1.8 Ah with connector				
Pack-NiCd 3C CON	28001221	5 pc(s).	10 pc(s).	0.540 kg
Pack-NiCd 4C CON	28001222	5 pc(s).	10 pc(s).	0.540 kg
Battery pack 4.5 Ah with connector				
Pack-NiCd 3D CON	89800389	5 pc(s).	10 pc(s).	0.534 kg
Pack-NiCd 4D CON	89800390	5 pc(s).	10 pc(s).	0.661 kg

1. Standards

- EN 55015
- EN 61000-3-2
- EN 61000-3-3
- EN 61347-1
- EN 61347-2-7
- EN 61347-2-13
- EN 61547
- EN 62384
- EN 62386-101 (according to DALI standard V2)
- EN 62386-102 (according to DALI standard V2)
- according to EN 50172
- according to EN 60598-2-22
- according to EN 62034

1.1 Glow-wire test

according to EN 60598-1 with increased temperature of 850 °C passed.

1.2 Insulation and electric strength testing of luminaires

Electronic LED Driver can be damaged by high voltage. This has to be considered during the routine testing of the luminaires in production.

According to IEC 60598-1 Annex Q (informative only!) or ENEC 303-Annex A, each luminaire should be submitted to an insulation test with 500 V_{DC} for 1 second. This test voltage should be connected between the interconnected phase and neutral terminals and the earth terminal. The insulation resistance must be at least 2 MΩ.

As an alternative, IEC 60598-1 Annex Q describes a test of the electrical strength with 1,500 V_{AC} (or 1,414 x 1,500 V_{DC}). To avoid damage to the electronic devices this test **must not be conducted**.

2. Thermal data

2.1 Temperature range

According to the standard IEC 60598-1 a LED Driver for remote installation has a max. case temperature of 90 °C. The ambient temperature range t_a for the EM powerLED PRO DIM SR 45W is defined to meet this requirement.

2.2 Expected lifetime

Average lifetime 50,000 hours under rated conditions with a failure rate of less than 10 %. Average failure rate of 0.2 % per 1000 operating hours.

Expected lifetime

Type	Output power	t_a	40 °C	50 °C
EM powerLED PRO DIM 103 / 104 SR 45W 50V	10 W	t_c	56 °C	66 °C
		lifetime	> 100,000 h	> 100,000 h
	20 W	t_c	59 °C	69 °C
		lifetime	> 100,000 h	> 100,000 h
	30 W	t_c	63 °C	73 °C
		lifetime	> 100,000 h	> 100,000 h
	40 W	t_c	65 °C	75 °C
		lifetime	> 100,000 h	80,000 h
	45 W	t_c	70 °C	x
		lifetime	80,000 h	x

x = not permitted

The relation of t_c to t_a temperature depends also on the luminaire design. If the measured t_c temperature is approx. 5 K below t_c max., t_a temperature should be checked and eventually critical components (e.g. ELCAP) measured. Detailed information on request.

2.3 Storage conditions

Humidity: 5 % up to max. 85 %,
not condensed
(max. 56 days/year at 85 %)

Storage temperature: -40 °C up to max. +80 °C

The devices have to be within the specified temperature range (t_a) before they are operated.

3. Installation / Wiring

3.1 Wiring diagrams

DALI

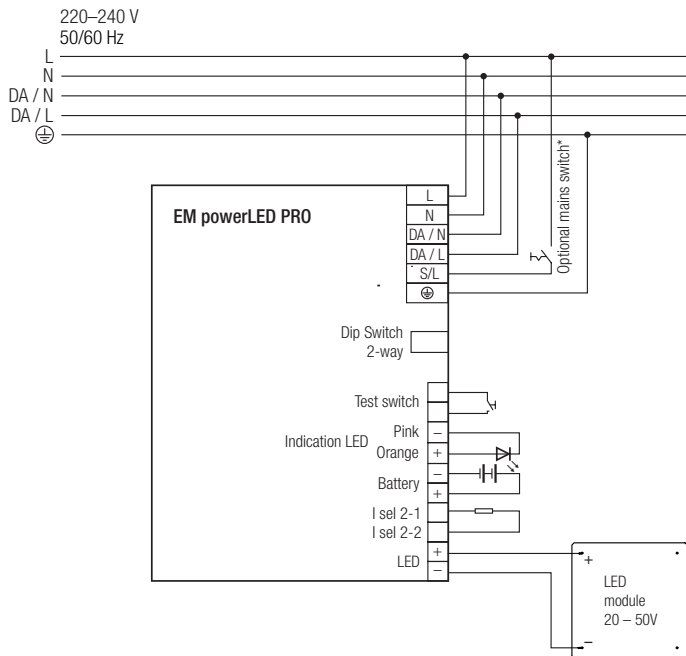

* If the optional mains switch is not used, connect S/L to L.

Recommendation to check glowing at standby in combination with class I luminaires.

switchDIM

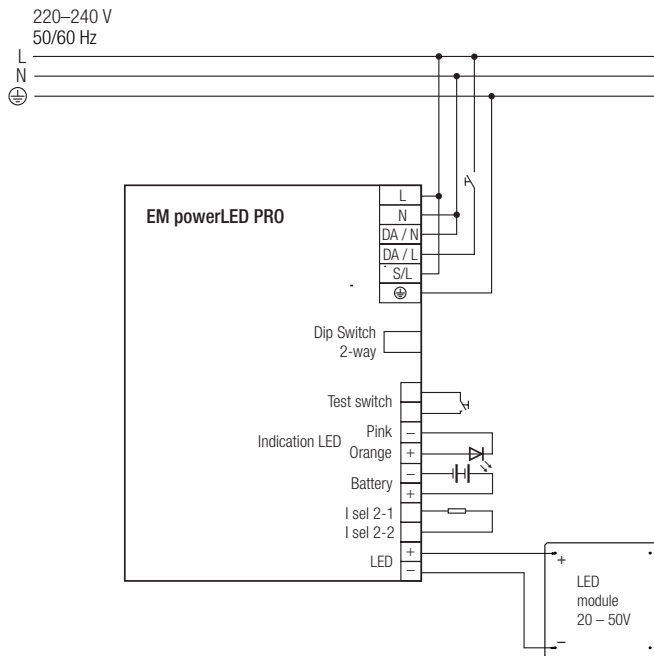

In switchDIM operation the emergency unit will work as SELFTTEST unit. All functions and duration tests will perform automatically. The randomized testing is not active. For details refer to chapter 7.12 Testing, DALI Control.

3.2 Wiring type and cross-section

Wiring

Mains (N, L, Earth, S/L)
DALI (DA/N, DA/L)
LED (LED +, LED -)
Batteries (Bat +, Bat -)
I sel 2

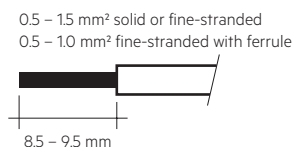

Wiring

Test switch
Indication LED

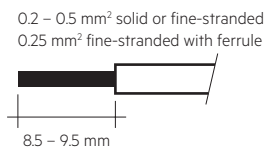

Use one wire for each terminal connector only.
Use each strain relief channel for one cable only.



max. Ø = 10 mm
min. Ø = 6,3 mm

Max. lead insulation diameter

Battery	2.1mm
Test switch	2.1mm
Indicator LED	2.1mm

Maximum lead length

LED	3 m
status indication LED	1 m
batteries	1.3 m

3.3 Release of the wiring

Press down the "push button" and remove the cable from front.

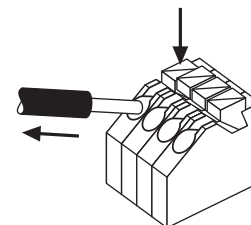

Installation instruction

Max. torque for the mounting screws: 0.5 Nm / M4.

3.4 Fixing conditions

Dry, acidfree, oilfree, fatfree. It is not allowed to exceed the maximum ambient temperature (ta) stated on the device. Minimum distances stated below are recommendations and depend on the actual luminaire. Is not suitable for fixing in corner.

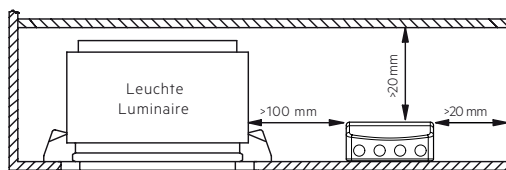

Device not suitable for covering with thermally insulating material according to IEC 60598-1 Ed.9

3.5 Wiring guidelines

- The cables should be run separately from the mains connections and mains cables to ensure good EMC conditions.
- The LED wiring should be kept as short as possible to ensure good EMC. The max. secondary cable length is 2 m (4 m circuit), this applies for LED output as well as for I-select 2.
- The secondary wires (LED module) should be routed in parallel to ensure good EMC performance.
- Secondary switching is not permitted.
- The LED Driver has no inverse-polarity protection on the secondary side. Wrong polarity can damage LED modules with no inverse-polarity protection.
- Wrong wiring of the LED Driver can lead to malfunction or irreparable damage.
- Maximum lead length for the test switch and Indicator LED connection is 1 m. The test switch and Indicator LED wiring should be separated from the LED leads to prevent noise coupling.
- Battery leads are specified with 0.5 mm cross section and a length of 1.3 m.
- If the optional mains switch is not used, connect S/L to L.
- To avoid the damage of the control gear, the wiring must be protected against short circuits to earth (sharp edged metal parts, metal cable clips, louver, etc.).

To ensure that a luminaire containing LED emergency units complies with EN 55015 for radio frequency conducted interference in both normal and emergency mode it is essential to follow good practice in the wiring layout.

Within the luminaire the switched and unswitched 50 Hz supply wiring must be routed as short as possible and be kept as far away as possible from the LED leads. Through wiring may affect the emc performance of the luminaire.

The length of LED leads must not be exceeded.

The output current depends on the forward voltage and the tolerance of the LED modules.

The mains power must be removed before changing the LED load.

3.6 Earth connection

The earth connection is conducted as protection earth (PE). The LED Driver can be earthed via earth terminal. If the LED Driver will be earthed, protection earth (PE) has to be used. There is no earth connection required for the functionality of the LED Driver. Earth connection is recommended to improve following behaviour:

- Electromagnetic interferences (EMI)
- LED glowing at standby
- Transmission of mains transients to the LED output

In general it is recommended to earth the LED Driver if the LED module is mounted on earthed luminaire parts respectively heat sinks and thereby representing a high capacity against earth.

3.7 External I-select 2 resistors on LED modules

LED modules with on-board I-select 2 resistors may cause irreparable damages, caused by surge / burst peaks.

4. Mechanical data

4.1 Housing properties

- Polycarbonat white / green
- Type of protection IP 20

4.2 Mechanical data accessories

LED status indicator

- Bi-colour
- Mounting hole 6.5 mm diameter, 1 – 1.6 mm thickness
- Lead length 1.0 m
- Insulation rating: 90 °C

Test switch

- Mounting hole 7.0 mm diameter
- Lead length 0.55 m

Battery leads

- Quantity: 1 red and 1 black
- Length: 1.3 m
- Wire type: 0.5 mm² solid conductor
- Insulation rating: 90 °C

Battery end termination

Push on 4.8 mm receptacle to suit battery spade fitted with insulating cover

Module end termination

8.0 mm stripped insulation

Two-piece batteries are supplied with a 200 mm lead with 4.8 mm receptacle at each end and insulating covers to connect the separate sticks together.

5. Electrical data

5.1 Operating window

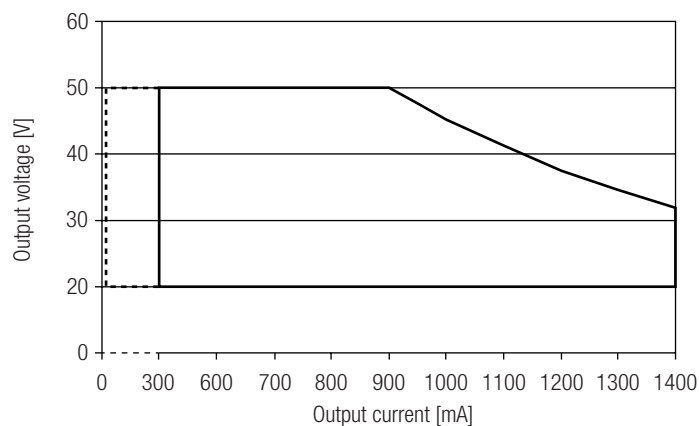

- Operating window 100 %
- - - - - Operating window dimmed

Make sure that the LED Driver is operated within the given window under all operating conditions, also in dimming operation. Otherwise certain limitations may occur. This is due to the nature of amplitude modulation dimming. The stated minimum output voltage shall not be undercut as this may cause the device to shut-down.

5.2 Efficiency vs load

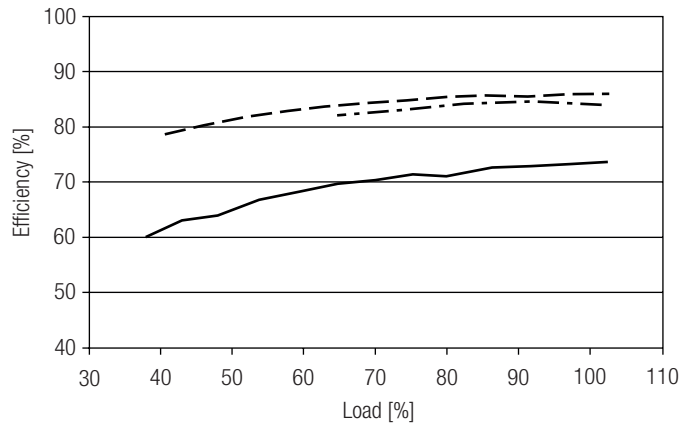

5.3 Power factor vs load

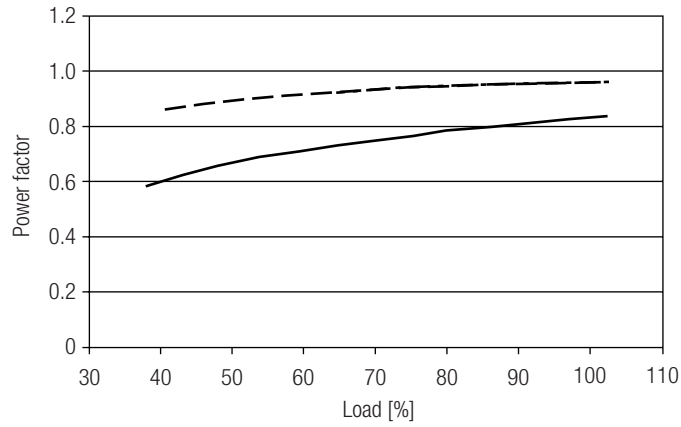

5.4 THD vs load

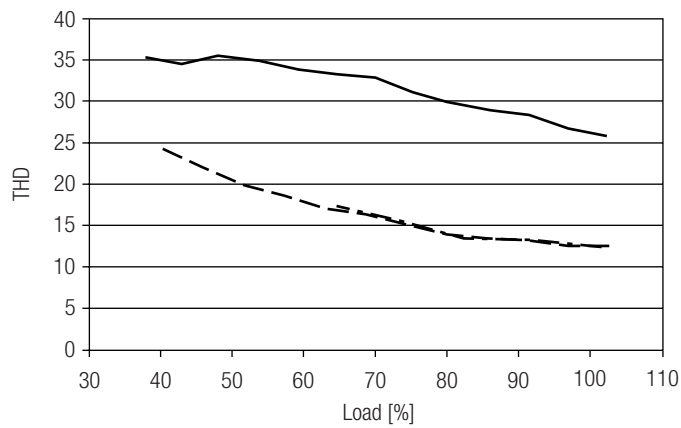

- 300 mA
- - - 900 mA
- . - . 1400 mA

100 % load corresponds to the max. output power (full load) according to the table on page 2.

5.5 Maximum loading of automatic circuit breakers

Automatic circuit breaker type	C10	C13	C16	C20	B10	B13	B16	B20	Inrush current	
Installation Ø	1.5 mm ²	1.5 mm ²	2.5 mm ²	4 mm ²	1.5 mm ²	1.5 mm ²	2.5 mm ²	4 mm ²	I _{max}	time
EM powerLED PRO DIM SR	18	26	30	36	9	13	15	18	23.9 A	187 µs

5.6 Harmonic distortion in the mains supply (at 230 V / 50 Hz and full load) in %

	THD	3.	5.	7.	9.	11.
EM powerLED PRO DIM SR	< 10	< 9	< 3	< 3	< 2	< 1

5.7 Insulation matrix

	Mains	Earth	Switched Live	Battery, LED, Test switch, Indicator LED	DALI	I-SELECT
Mains	-	•	•	••	•	•
Earth	•	-	•	•	•	•
Switched Live	•	•	-	••	•	•
Battery, LED, Test switch, Indicator LED	••	•	••	-	•	••
DALI	•	•	•	•	-	•
I-SELECT	•	•	•	••	•	-

- Represents basic insulation
- Represents double or reinforced insulation

DALI terminals are not SELV. Wire the terminals in accordance with the requirements of low voltage installations. The driver fulfils the requirements for Class II when installed without an earth and is double insulated against electric shock.

5.8 Dimming

Dimming range 1% to 100 %

Digital control with:

- DSI signal: 8 bit Manchester Code
Speed 1% to 100 % in 1.4 s
 - DALI signal: 16 bit Manchester Code
Speed 1% to 100 % in 0.2 s
- Programmable parameter:
Minimum dimming level
Maximum dimming level
Default minimum = 1 %
Programmable range 1% ≤ MIN ≤ 100 %
Default maximum = 100 %
Programmable range 100 % ≥ MAX ≥ 1 %

Dimming curve is adapted to the eye sensitiveness.

Dimming is realized by amplitude dimming.

5.9 Dimming characteristics

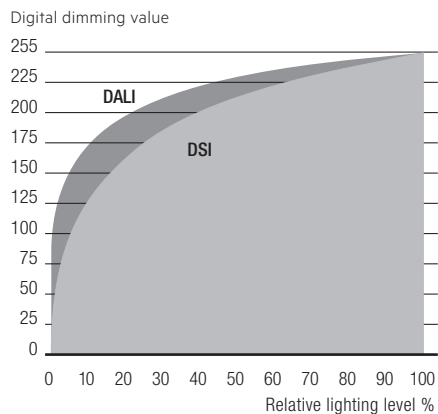

Dimming characteristics as seen by the human eye

5.10 Typ. LED current/voltage characteristics

The LED current in emergency mode is automatically adjusted by the EM powerLED module based on the total forward voltage of the LED modules connected and the associated battery.

EM powerLED PRO DIM 103 SR 45W 50V – 3 cells
 Article number: 89800434 / 89800505
 3.6 V battery voltage
 750 – 960 mA battery discharge current (tolerance)

EM powerLED PRO DIM 104 SR 45W 50V – 4 cells
 Article number: 89800416 / 89800509
 4.8 V battery voltage
 750 – 960 mA battery discharge current (tolerance)

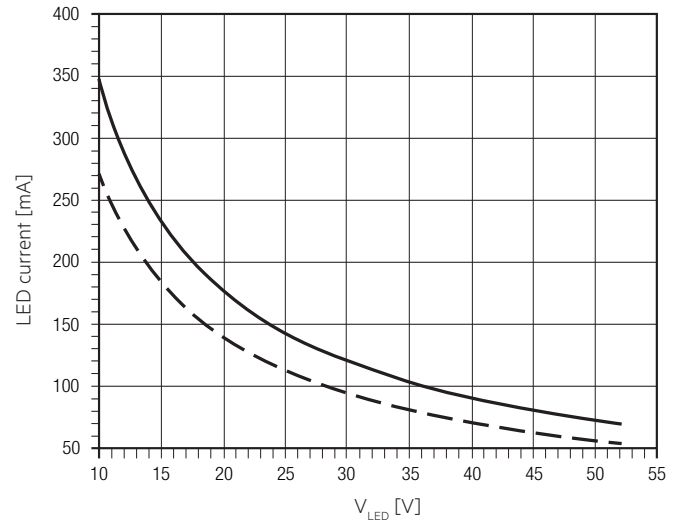
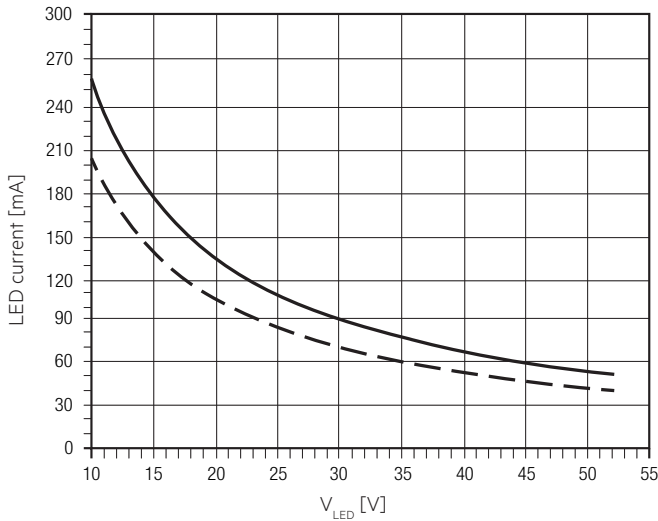

--- LED current at nominal battery voltage and min. battery discharge current
 — LED current at nominal battery voltage and max. battery discharge current

LED peak current at start in emergency mode – 3 cells

Voltage	Inrush current	Duration
19.8 V	329 mA	12.9 ms
22.6 V	297 mA	12.0 ms
25.3 V	265 mA	11.5 ms
28.0 V	244 mA	10.8 ms
30.7 V	234 mA	10.3 ms
33.4 V	216 mA	10.1 ms
36.1 V	202 mA	9.8 ms
38.8 V	192 mA	9.7 ms
41.5 V	183 mA	9.1 ms
44.2 V	174 mA	8.8 ms
47.0 V	168 mA	8.1 ms
49.7 V	161 mA	6.9 ms

LED peak current at start in emergency mode – 4 cells

Voltage	Inrush current	Duration
19.8 V	395 mA	16.5 ms
22.6 V	360 mA	15.3 ms
25.3 V	338 mA	14.5 ms
28.0 V	308 mA	14.0 ms
30.7 V	293 mA	13.8 ms
33.4 V	270 mA	12.7 ms
36.1 V	263 mA	12.1 ms
38.8 V	248 mA	11.7 ms
41.5 V	242 mA	9.8 ms
44.2 V	225 mA	8.9 ms
47.0 V	218 mA	7.8 ms
49.7 V	211 mA	7.5 ms

Note: LED peak current is measured at the max. battery discharge current.

6. Interfaces / communication

Use EM powerLED PRO DIM only on DALI control systems which can handle multi device types. EM powerLED PRO DIM combines device types DT1 and DT6.

6.1 Control input (DA/N, DA/L)

Digital DALI signal or switchDIM can be wired on the same terminals (DA/N and DA/L).

The control input is non-polar for digital control signals (DALI, DSI). The control signal is not SELV. Control cable has to be installed in accordance to the requirements of low voltage installations. Different functions depending on each module.

6.2 Control input ready2mains (S/L, N)

The digital ready2mains protocol is modulated onto the mains signal which is wired to the mains terminal (L and N).

6.3 switchDIM

Integrated switchDIM function allows a direct connection of a pushbutton for dimming and switching.

Brief push (< 0.6 s) switches LED Driver ON and OFF. The dimm level is saved at power-down and restored at power-up.

When the pushbutton is held, LED modules are dimmed. After repush the LED modules are dimmed in the opposite direction.

In installations with LED Drivers with different dimming levels or opposite dimming directions (e.g. after a system extension), all LED Drivers can be synchronized to 50% dimming level by a 10 s push.

Use of pushbutton with indicator lamp is not permitted.

7. Functions

7.1 Function: adjustable current

The output current of the LED Driver can be adjusted in a certain range. For adjustment there are three options available.

Option 1: DALI

Adjustment is done by masterCONFIGURATOR (see masterCONFIGURATOR documentation).

Option 2: I-select 2

By inserting a suitable resistor into the I-select 2 interface, the current value can be adjusted. The relationship between output current and resistor value can be found in the chapter "Accessories I-SELECT 2 Plugs".

If the resistor is connected by wires a consistent base insulation must be ensured. Furthermore, a max. wire length of 2 m may not be exceeded and potential interferences have to be avoided.



Please note that the resistor values for I-select 2 are not compatible with I-select (generation 1). Installation of an incorrect resistor may cause irreparable damage to the LED module(s).

Resistors for the main output current values can be ordered from Tridonic (see accessories).

Option 3: ready2mains

Adjustment is done by the ready2mains programmer and the corresponding configuration software (see ready2mains documentation). Send the ready2mains signal to S/L and N.

The priority for current adjustment methods is DALI (highest priority), I-select 2, ready2mains (lowest priority).

7.2 Short-circuit behaviour

In case of a short-circuit at the LED output the LED output is switched off. After restart (SL off/on) of the LED Driver the output will be activated again. The restart can either be done via mains reset or via interface (DALI, DSI, switchDIM).

7.3 No-load operation

The LED Driver will not be damaged in no-load operation. The output will be deactivated and is therefore free of voltage. If a LED load is connected the device has to be restarted (SL off/on) before the output will be activated again.

7.4 Overload protection

If the output voltage range is exceeded the LED Driver turns off the LED output. After restart (SL off/on) of the LED Driver the output will be activated again. The restart can either be done via mains reset or via interface (DALI, DSI, switchDIM).

7.5 Overtemperature protection

The LED Driver is protected against temporary thermal overheating. If the temperature limit is exceeded the output current of the LED module(s) is reduced. The temperature protection is activated approx. +5 °C above $t_{c\ max}$ (see page 2). On DC operation this function is deactivated to fulfill emergency requirements.

7.6 Hot plug-in

Hot plug-in is not supported due to residual output voltage of > 0 V.

If a LED load is connected the device has to be restarted before the output will be activated again.

This can be done via mains reset or via interface (DALI, DSI, switchDIM, ready2mains).

7.7 corridorFUNCTION

The corridorFUNCTION can be programmed in two different ways.

To program the corridorFUNCTION by means of software a DALI-USB interface is needed in combination with a DALI PS. The software can be the masterCONFIGURATOR.

To activate the corridorFUNCTION without using software a voltage of 230 V has to be applied for five minutes at the switchDIM connection.

The unit will then switch automatically to the corridorFUNCTION.

Note:

If the corridorFUNCTION is wrongly activated in a switchDIM system (for example a switch is used instead of pushbutton), there is the option of installing a pushbutton and deactivating the corridorFUNCTION mode by five short pushes of the button within three seconds.

switchDIM and corridorFUNCTION are very simple tools for controlling gears with conventional pushbuttons or motion sensors.

To ensure correct operation a sinusoidal mains voltage with a frequency of 50 Hz or 60 Hz is required at the control input.

Special attention must be paid to achieving clear zero crossings. Serious mains faults may impair the operation of switchDIM and corridorFUNCTION.

7.8 Constant light output (CLO)

The luminous flux of an LED decreases constantly over the lifetime. The CLO function ensures that the emitted luminous flux remains stable. For that purpose the LED current will increase continuously over the LED lifetime.

In masterCONFIGURATOR it is possible to select a start value (in percent) and an expected lifetime. The LED Driver adjusts the current afterwards automatically.

7.9 Power-up/-down fading

The power-up/-down function offers the opportunity to modify the on-/off behavior. The time for fading on or off can be adjusted in a range of 0.2 to 16 seconds. According to this value, the device dims either from 0 % up to the power-on level or from the current set dim level down to 0 %. This feature applies while operating via switchDIM and when switching the mains voltage on or off. By factory default no fading time is set (= 0 seconds).

7.10 Software / programming

With appropriate software and a interface different functions can be activated and various parameters can be configured in the LED Driver. To do so, a DALI-USB or ready2mains programmer and the software (masterCONFIGURATOR) are required.

7.11 masterCONFIGURATOR

From version 2.8:

For programming functions (CLO, I-select 2, power-up fading, corridorFUNCTION) and device settings (fade time, ePowerOnLevel, DC level, etc.). For further information see masterCONFIGURATOR manual.

7.12 Status indication

System status is indicated by a bi-colour LED and by a DALI status flag.

LED indication	Status	Comment
Permanent green	System OK	AC mode
Fast flashing green (0,1 sec on – 0,1 sec off)	Function test underway	
Slow flashing green (1 sec on – 1 sec off)	Duration test underway	
Red LED on	Load failure	Open circuit / Short circuit / LED failure
Slow flashing red (1 sec on – 1 sec off)	Battery failure	Battery failed the duration test or function test / Battery is defect or deep discharged/ Incorrect battery voltage
Fast flashing red (0,1 sec on – 0,1 sec off)	Charging failure	Incorrect charging current
Double pulsing green	Inhibit mode	Switching into inhibit mode via controller
Binary transmission of address via green/red LED	Address identification	During address identification mode
Green and red off	DC mode	Battery operation (emergency mode)

7.13 Testing

DALI Control Emergency DT1

A DALI command from a suitable control unit can be used to initiate function and duration tests at individually selected times. Status flags are set for report back and data logging of results.

When a DALI bus has not been connected or when a DALI bus is connected but the DALI default DELAY and INTERVAL times have not been reset by sending appropriate DALI commands, then the EM powerLED PRO will conduct self-tests in accordance with the default times set within the EEPROM. These default times are factory pre-set, in accordance with the DALI standard EN 62386-202, to conduct an automatic function test every 7 days and a duration test every 52 weeks. Since the DELAY time is factory preset to Zero, all units are tested at the same time. Test times can be changed with a command over the DALI bus.

The DELAY and INTERVAL time values must be re-set when the emergency system test times are to be scheduled by a DALI control and monitoring system.

Note that once the default values have been set to Zero, tests will only be conducted following a command from the control system. If the DALI bus is disconnected the EM powerLED PRO does not revert to self-testing mode.

Note: If the battery is connected the DALI communication is only possible after power reset.

Addressing

The EM powerLED PRO includes the EZ easy addressing system which allows addressing and identification by using the bi-colour LED. Binary address codes given by the LED can be simply converted to the DALI addresses 0 to 63. For single handed addressing using this method it is necessary to send a broadcast ident command every 3 to 9 seconds. During this command the LEDs will be switched off and the indication LED will flash the 6 bit binary address preceded by a 3 second start indication period.

Commissioning

After installation of the luminaire and initial connection of the mains supply and battery supply to the EM powerLED PRO the unit will commence charging the batteries for 20 hours (initial charge). Afterwards the module will conduct a commissioning test for the full duration. The 20 hours recharge occurs also if a new battery is connected or the module exits the rest mode condition. The following automatic commissioning duration test is only performed when a battery is replaced and fully charged (after 20 hrs) and the interval time is not set to zero, otherwise the system is expected to perform the testing.

Functional test

The time of day and frequency of the 5 seconds function test can be set by the DALI controller. The default setting is a 5 seconds test on a weekly basis.

Duration test

The time of day and frequency of the duration test can be set by the DALI controller. The default setting is a duration test conducted every 52 weeks.

For 2 h operation:

The first commissioning duration test has a time of 120 minutes, subsequent through life tests are conducted for 90 minutes. When the battery is changed or disconnected and re-connected the unit will next conduct a 120 minute test.

Prolong time

Prolong time can be set by the DALI controller. This is the delay time between return of the mains supply and the end of the emergency operation. The default prolong time is set as 0 minutes as specified within the DALI standard.

Indicator LED will stay off for the duration of the prolong time.

Rest Mode / Inhibit Mode

Emergency operation is automatically started when the mains supply is switched off. If the Rest Mode is activated, the discharging of the battery will be minimized by switching off the LED output. If the Inhibit Mode has been activated before the mains supply is switched off, Rest Mode will be automatically switched on if the mains supply is switched off within 15 minutes. Rest Mode and Inhibit Mode can be initiated by the DALI controller. The REST command has to be sent after the mains supply has been disconnected and whilst the EM powerLED PRO is in emergency operation. The INHIBIT command has to be sent while the EM powerLED PRO is supplied by mains.

After a mains reset the EM powerLED PRO exits the Rest Mode. Rest Mode and Inhibit Mode can both be disabled by sending the RE-LIGHT/RESET INHIBIT command.

Test switch

An optional test switch can be wired to each EM converterLED ST. This can be used to:

- initiate a 5 seconds function test: press 200 ms < T < 1 s
- execute function test as long as switch pressed: press > 1 s
- reset selftest timer (adjust local timing): press > 10 s

Timer reset functionality

The timer for function and duration test can be set to a particular time of the day by either pressing the test switch for longer than 10 seconds or cycling the unswitched line supply 5 times within 1 minute. The timer adjustment

will enable the test start time to be defined manually at time in day when the timer was reset. It will also disable the adaptive test algorithm thereby forcing the unit to perform the test at the same time rather than it being defined by the adaptive algorithm. This function will only work provided the interval time is greater than zero (automatic test mode enabled). The delay timer value set when the unit was commissioned will be reloaded in order to randomise the tests between adjacent units.

The factory programmed delay offset (1 – 28 days) will be loaded after the reset into the delay timer for the function and duration test in order to randomize the tests between adjacent units.

DALI Controller

DALI controllers and hardware/software solutions are available from Tridonic. Please refer to the Lighting controls section.

8. Battery data

8.1 Battery selection

EM powerLED PRO DIM 45 W 50 V, 1 / 3 h

		Type	EM powerLED PRO DIM 103 SR NiCd 45W 50V	EM powerLED PRO DIM 103 SR NiMH 45W 50V	EM powerLED PRO DIM 104 SR NiCd 45W 50V	EM powerLED PRO DIM 104 SR NiMH 45W 50V
		Article no.	89800505		89800509	
		Cells	3 cells		4 cells	
		Duration	1 h	2 / 3 h	1 h	2 / 3 h

Technology and capacity	Design	Number of cells	Type	Article no.	Assignable batteries				
NiCd 4 Ah D cells	stick	1 x 3	Accu-NiCd 3A 55	28002773	•				
	stick	1 x 4	Accu-NiCd 4A 55	89800089			•		
	stick + stick	2 + 2	Accu-NiCd 4C 55	28002775			•		
	side by side	3 x 1	Accu-NiCd 3B 55	89800384		•			
	side by side	4 x 1	Accu-NiCd 4B 55	89800385			•		
NiCd 1,8 Ah Cs cells	remote box	1 x 3	Pack-NiCd 3C CON	28001221	•				
	remote box	1 x 4	Pack-NiCd 4C CON	28001222			•		
NiCd 4,5 Ah D cells	remote box	1 x 3	Pack-NiCd 3D CON	89800389		•			
	remote box	1 x 4	Pack-NiCd 4D CON	89800390			•		
NiMH 2,2 Ah Cs cells	stick	1 x 3	Accu-NiMH 3A	28002088	•	•			
	stick	1 x 4	Accu-NiMH 4A	28002089			•		•
NiMH 4 Ah LA cells	stick	1 x 3	Accu-NiMH 4Ah 3A CON	89800441		•			
	stick	1 x 4	Accu-NiMH 4Ah 4A CON	89800442			•		•
	stick + stick	2 + 2	Accu-NiMH 4Ah 4C CON	89800438			•		•

8.2 Battery charge / discharge

EM powerLED PRO DIM 45 W 50 V, 1 / 2 / 3 h

	Type	EM powerLED PRO DIM 103 SR NiCd 45W 50V		EM powerLED PRO DIM 103 SR NiMH 45W 50V		EM powerLED PRO DIM 104 SR NiCd 45W 50V		EM powerLED PRO DIM 104 SR NiMH 45W 50V	
		89800434		89800505		89800416		89800509	
	Article no.	3 cells				4 cells			
	Cells	3 cells				4 cells			
	Duration	1 h	2 / 3 h	1 h	2 / 3 h	1 h	2 / 3 h	1 h	2 / 3 h
Battery charge time	Initial charge	20 h							
	Fast recharge	10 h	15 h	10 h	15 h	10 h	15 h	10 h	15 h
	Trickle charge	continuously							
Charge current	Initial charge	130 mA	300 mA	130 mA	300 mA	130 mA	300 mA	130 mA	300 mA
	Fast recharge	210 mA	330 mA	210 mA	330 mA	210 mA	330 mA	210 mA	330 mA
	Trickle charge	50 mA	130 mA	127 mA / 4 min. 0 mA / 16 min.	200 mA / 4 min. 0 mA / 16 min.	50 mA	130 mA	127 mA / 4 min. 0 mA / 16 min.	200 mA / 4 min. 0 mA / 16 min.
Power consumption	Initial charge	2.2 W	3.7 W	2.2 W	3.7 W	2.5 W	4.4 W	2.5 W	4.4 W
	Fast recharge	2.9 W	4.0 W	2.9 W	4.1 W	3.4 W	4.8 W	3.3 W	4.8 W
	Trickle charge	1.6 W	2.2 W	1.6 / 2.2 W	1.6 / 2.8 W	1.7 W	2.5 W	1.6 / 2.5 W	1.6 / 3.3 W
	Discharge current	850 – 960 mA	850 – 960 mA	850 – 960 mA	850 – 960 mA	850 – 960 mA	850 – 960 mA	850 – 960 mA	850 – 960 mA

8.3 Accu-NiCd**4.2 / 4.5 Ah**

Battery voltage/cell	1.2 V
Cell type	D
Case temperature range to ensure 4 years design life	+5 °C to +55 °C
Max. short term battery case temperature (shorter than 1 month over the battery lifetime)	70 °C
Max. number discharge cycles	4 cycles per year plus 4 cycles during comissioning
Max. storage time	6 months

8.4 Accu-NiMh**2.2 Ah**

Battery voltage/cell	1.2 V
Cell type	Cs
Case temperature range to ensure 4 years design life	+5 °C to +50 °C
Max. short term battery case temperature (shorter than 1 month over the battery lifetime)	70 °C
Max. number discharge cycles	4 cycles per year plus 30 cycles during comissioning
Max. storage time	12 months

4.0 Ah

Battery voltage/cell	1.2 V
Cell type	LA
Case temperature range to ensure 4 years design life	+5 °C to +45 °C
Max. short term battery case temperature (shorter than 1 month over the battery lifetime)	70 °C
Max. number discharge cycles	4 cycles per year plus 30 cycles during comissioning
Max. storage time	12 months

8.5 Accupack-NiCd**1.8 Ah**

Battery voltage/cell	1.2 V
Cell type	Cs
Ambient temperature range to ensure 4 years design life tc point	+5 °C to +40 °C +45 °C
Max. short term battery case temperature (shorter than 1 month over the battery lifetime)	70 °C
Max. number discharge cycles	4 cycles per year plus 4 cycles during comissioning
Max. storage time	6 months

4.5 Ah

Battery voltage/cell	1.2 V
Cell type	D
Ambient temperature range to ensure 4 years design life tc point	+5 °C to +40 °C +45 °C
Max. short term battery case temperature (shorter than 1 month over the battery lifetime)	70 °C
Max. number discharge cycles	4 cycles per year plus 4 cycles during comissioning
Max. storage time	6 months

8.6 Accupack-NiMH**2.2 Ah**

Battery voltage/cell	1.2 V
Cell type	Cs
Ambient temperature range to ensure 4 years design life tc point	+5 °C to +35 °C +40 °C
Max. short term battery case temperature (shorter than 1 month over the battery lifetime)	70 °C
Max. number discharge cycles	4 cycles per year plus 4 cycles during comissioning
Max. storage time	12 months

4.0 Ah

Battery voltage/cell	1.2 V
Cell type	LAL
Ambient temperature range to ensure 4 years design life tc point	+5 °C to +35 °C +40 °C
Max. short term battery case temperature (shorter than 1 month over the battery lifetime)	70 °C
Max. number discharge cycles	4 cycles per year plus 4 cycles during comissioning
Max. storage time	12 months

8.7 Batteries

Connection method: 4.8 x 0.5 mm spade tag welded to end of cell

For stick packs this connection is accessible after the battery caps have been fitted.

To inhibit inverter operation disconnect the batteries by removing the connector from the battery spade tag.

For further information refer to corresponding battery datasheet.

8.8 Storage, installation and commissioning

Relevant information about storage conditions, installation and commissioning are provided in the battery datasheets.

9. Miscellaneous**9.1 Maximum number of switching cycles**

All LED Drivers are tested with 50,000 switching cycles.
The actually achieved number of switching cycles is significantly higher.

9.2 Additional information

Additional technical information at www.tridonic.com → Technical Data

Lifetime declarations are informative and represent no warranty claim.
No warranty if device was opened.