

EM powerLED BASIC FX SC LiFePO4 32 W

Combined emergency lighting LED driver



LiFeGuard

Product description

- _ Combined emergency LED driver for manual testing
- _ For self-contained emergency lighting
- _ Can be either used build-in or independent with clip-on strain-relief (see accessory)
- _ Max. output power 32 W
- _ EM = Emergency
- _ Nominal lifetime up to 100,000 h
- _ 5 years guarantee (conditions at <https://www.tridonic.com/en/int/services/manufacturer-guarantee-conditions>)

Functions

- _ Adjustable output current between 350 and 700 mA via I-SELECT 2 plugs
- _ Protective features (overtemperature, short-circuit, overload, no-load, input voltage range)
- _ Suitable for emergency escape lighting systems acc. to EN 50172
- _ 1 or 3 h rated duration depending on connected battery
- _ Constant power output in emergency mode

Battery management

- _ Intelligent charge system
- _ Deep discharge protection
- _ Temperature protection
- _ Polarity reversal protection for battery provided by 3-pole connector

Batteries

- _ LiFePO4 batteries with Tridonic LiFeGuard
- _ Temperature-protected
- _ Overcharge-/Overdischarge protection
- _ Ensures safety in use
- _ LiFePO4: up to 12 years design life
- _ 8 years guarantee for LiFePO4 batteries (conditions at <https://www.tridonic.com/en/int/services/manufacturer-guarantee-conditions>)
- _ For battery compatibility refer to data sheet, battery selection

Website

<http://www.tridonic.com/89800687>

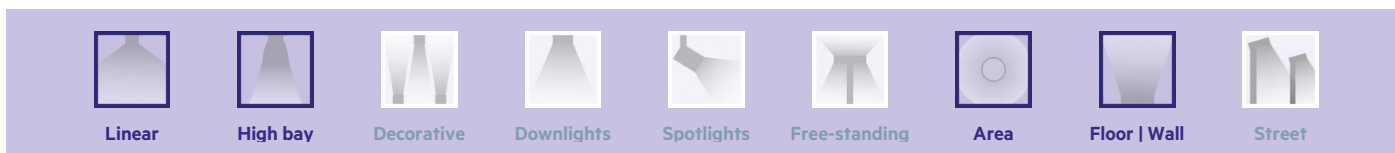

EM powerLED BASIC FX SC LiFePO4 32 W

Combined emergency lighting LED driver

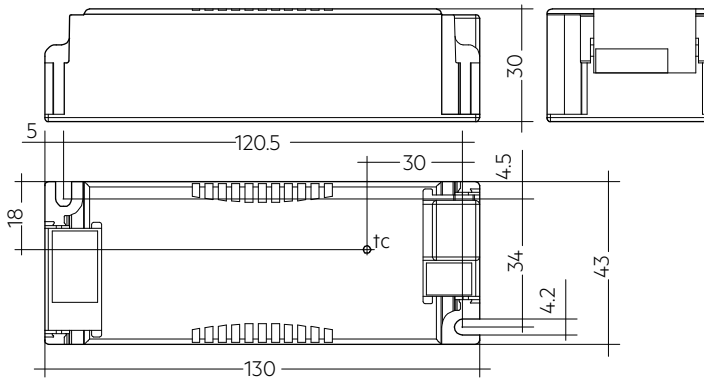

Ordering data

Type	Article number	Rated duration	Packaging, carton	Packaging, pallet	Weight per pc.
EM pLED BASIC FX 102 SC LiFePO4 32W 50V	89800687	1/3 h	10 pc(s).	1,000 pc(s).	0.115 kg

Technical data

Rated supply voltage	220 – 240 V
AC voltage range	198 – 264 V
Mains frequency	50 / 60 Hz
Overvoltage protection	320 V (for 48 h)
Typ. rated current (at 230 V, 50 Hz, full load, charging) ①	185 mA
Max. input power	41 W
Typ. efficiency (at 230 V, 50 Hz, full load, charging) ①	84 %
λ (at 230 V, 50 Hz, full load, charging)	0.95
Typ. input current in no-load operation (charging)	20 mA
Typ. input power in no-load operation (charging)	1.1 W
In-rush current (peak / duration)	4 A / 260 μs
THD (at 230 V, 50 Hz, full load)	14 %
Starting time (at 230 V, 50 Hz, full load)	< 500 ms
Turn off time (at 230 V, 50 Hz, full load)	< 50 ms
Switchover time (AC/EM)	< 500 ms
Output current tolerance	< 5 %
Max. output current peak (non-repetitive)	< 35 %
Output LF current ripple (< 120 Hz)	5 %
U-OUT (including open- / short-circuit and double load)	60 V
Max. open circuit voltage	60 V
Mains voltage changeover threshold	According to EN 60598-2-22
Max. casing temperature tc	80 °C
Ambient temperature ta at ≤ 25 W ②	-25 ... +50 / -25 ... +40 °C
Ambient temperature ta at > 25 W ②	-25 ... +45 / -25 ... +35 °C
Mains surge capability (between L - N)	1.2 kV
Surge voltage at output side (against PE)	2.4 kV
Mains surge capability (between L/N - PE)	2.4 kV
Lifetime	up to 100,000 h
Guarantee (conditions at www.tridonic.com)	5 Year(s)
Dimensions L x W x H	130 x 43 x 30 mm

Approval marks



Standards

EN 55015, EN 60068-2-29, EN 60068-2-30, EN 60068-2-64, EN 61000-3-2, EN 61000-3-3, EN 61347-1, EN 61347-2-7, EN 61347-2-13, EN 62384, EN 61547, according to EN 50172, according to EN 60598-2-22

Specific technical data

Type	Number of battery cells	Output current ^{①②}	Min. output voltage	Max. output voltage	Max. output power	Typ. power consumption (at 230 V, 50 Hz)		Typ. current consumption (at 230 V, 50 Hz)		I-SELECT resistor value ^⑥
						Min. load ^③	Max. load ^③	Min. load ^③	Max. load ^③	
Normal operation										
EM pLED BASIC FX 102 SC LiFePO4 32W 50V	-	350 mA	15 V	50 V	17.5 W	10.0 / 9.0 W	23.0 / 22.0 W	55 / 50 mA	110 / 105 mA	-
EM pLED BASIC FX 102 SC LiFePO4 32W 50V	-	400 mA	15 V	50 V	20.0 W	11.0 / 10.0 W	26.0 / 25.0 W	60 / 55 mA	120 / 115 mA	12.50 kΩ
EM pLED BASIC FX 102 SC LiFePO4 32W 50V	-	450 mA	15 V	50 V	22.5 W	12.0 / 11.0 W	28.5 / 27.5 W	65 / 60 mA	130 / 125 mA	11.11 kΩ
EM pLED BASIC FX 102 SC LiFePO4 32W 50V	-	500 mA	15 V	50 V	25.0 W	12.7 / 11.7 W	31.0 / 30.0 W	67 / 60 mA	135 / 130 mA	10.00 kΩ
EM pLED BASIC FX 102 SC LiFePO4 32W 50V	-	550 mA	15 V	50 V	27.5 W	13.7 / 12.7 W	34.0 / 33.0 W	70 / 65 mA	155 / 150 mA	9.09 kΩ
EM pLED BASIC FX 102 SC LiFePO4 32W 50V	-	600 mA	15 V	50 V	30.0 W	14.7 / 13.7 W	37.0 / 36.0 W	75 / 70 mA	165 / 160 mA	8.33 kΩ
EM pLED BASIC FX 102 SC LiFePO4 32W 50V	-	650 mA	15 V	50 V	32.5 W	15.7 / 14.7 W	39.5 / 38.5 W	80 / 75 mA	180 / 165 mA	7.69 kΩ
EM pLED BASIC FX 102 SC LiFePO4 32W 50V	-	700 mA	15 V	46 V	32.5 W	16.0 / 15.0 W	39.2 / 38.2 W	80 / 75 mA	175 / 170 mA	0.00 kΩ
Emergency operation										
EM pLED BASIC FX 102 SC LiFePO4 32W 50V	1	-	15 V	50 V	2.3 W	-	-	-	-	-
EM pLED BASIC FX 102 SC LiFePO4 32W 50V	3	-	15 V	50 V	2.3 W	-	-	-	-	-

① Depending on the selected output current.

② Ambient temperature with strain relief: ta max. (≤ 25 W) = 40 °C, ta max (> 25 W) = 35 °C

③ Output current is mean value.

④ The table only lists a number of possible operating points but does not cover each single point. The output current can be set within the total value range in 1-mA-steps.

⑤ Charging / Not charging

⑥ Not compatible with I-SELECT (generation 1). Calculated resistor value.

Strain-relief set 43x30mm

Accessory



Product description

- _ Optional strain-relief set for independent applications
- _ Transforms the LED driver into a fully class II compatible LED driver (e.g. ceiling installation)
- _ Easy and tool-free mounting to the LED driver, screwless cable-clamp channels for long strain-relief (30 x 43 x 30 mm)
- _ With screws for short strain-relief (15 x 34 x 30 mm)
- _ Overall length = length L (LED driver) + 2 x 30 mm (long strain-relief set), 2 x 15 mm (short strain-relief) or long and short strain-relief any combination
- _ Standard SC (L = 30 mm) available as non-pre-assembled and pre-assembled
- _ Short SC (L = 15 mm) only pre-assembled available

Website

<http://www.tridonic.com/28001168>

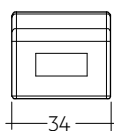
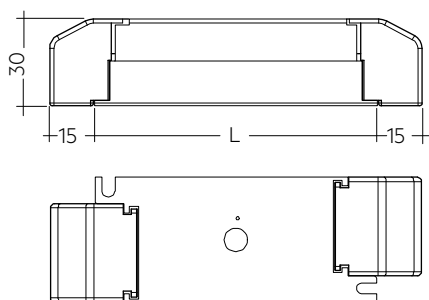

Permissible
cable jacket
diameter:
3 – 9 mm

Ordering data

Type	Article number	Packaging, carton ^①	Packaging, outer box	Weight per pc.
ACU SC 43x30mm CLIP-ON SR SET	28001168	10 pc(s).	500 pc(s).	0.018 kg
ACU SC 43x30mm CLIP-ON SR SET 300	28001351	300 pc(s).	300 pc(s).	0.033 kg
ACU SC 30x43x30mm CLIP-ON SR PA	28001699	10 pc(s).	500 pc(s).	0.015 kg
ACU SC 15x43x30mm CLIP-ON SR PA	28001574	10 pc(s).	1,200 pc(s).	0.012 kg

Approval marks



^① 28001168: A carton of 10 pcs. is equal to 10 sets, each with 2 strain-reliefs parts. 28001351: A carton of 300 pcs. is equal to 300 sets, each with 2 strain-reliefs parts. 28001699 + 28001574: A carton contains exactly 10 pcs. strain-reliefs (no sets).

I-SELECT 2 PLUG PRE / EXC

Accessory

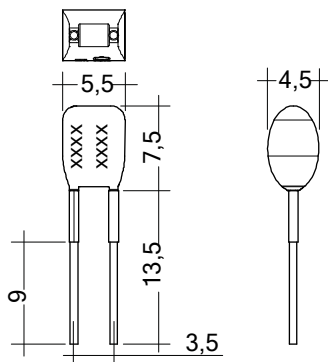
**Product description**

- _ Ready-for-use resistor to set output current value
- _ Compatible with LED driver featuring I-select 2 interface; not compatible with I-SELECT (generation 1)
- _ Resistor is base insulated
- _ Resistor power 0.25 W
- _ Current tolerance $\pm 2\%$ additional to output current tolerance
- _ Compatible with LED driver series PRE and EXC

Example of calculation

- _ $R [k\Omega] = 5 V / I_{out} [mA] \times 1000$
- _ E96 resistor value used
- _ Resistor value tolerance $\leq 1\%$; resistor power $\geq 0.1 W$; base insulation necessary
- _ When using a resistor value beyond the specified range, the output current will automatically be set to the minimum value (resistor value too big), respectively to the maximum value (resistor value too small)

Website

<http://www.tridonic.com/28001110>

**Ordering data**

Type	Article number	Colour	Marking	Current	Resistor value	Packaging, bag	Weight per pc.
I-SELECT 2 PLUG 350MA BL	28001110	Blue	0350 mA	350 mA	14.30 k Ω	10 pc(s).	0.001 kg
I-SELECT 2 PLUG 375MA BL	28001111	Blue	0375 mA	375 mA	13.30 k Ω	10 pc(s).	0.001 kg
I-SELECT 2 PLUG 400MA BL	28001112	Blue	0400 mA	400 mA	12.40 k Ω	10 pc(s).	0.001 kg
I-SELECT 2 PLUG 425MA BL	28001251	Blue	0425 mA	425 mA	11.80 k Ω	10 pc(s).	0.001 kg
I-SELECT 2 PLUG 450MA BL	28001113	Blue	0450 mA	450 mA	11.00 k Ω	10 pc(s).	0.001 kg
I-SELECT 2 PLUG 475MA BL	28001252	Blue	0475 mA	475 mA	10.50 k Ω	10 pc(s).	0.001 kg
I-SELECT 2 PLUG 500MA BL	28001114	Blue	0500 mA	500 mA	10.00 k Ω	10 pc(s).	0.001 kg
I-SELECT 2 PLUG 525MA BL	28001960	Blue	0525 mA	525 mA	9.53 k Ω	10 pc(s).	0.001 kg
I-SELECT 2 PLUG 550MA BL	28001115	Blue	0550 mA	550 mA	9.09 k Ω	10 pc(s).	0.001 kg
I-SELECT 2 PLUG 600MA BL	28001116	Blue	0600 mA	600 mA	8.25 k Ω	10 pc(s).	0.001 kg
I-SELECT 2 PLUG 650MA BL	28001117	Blue	0650 mA	650 mA	7.68 k Ω	10 pc(s).	0.001 kg
I-SELECT 2 PLUG 700MA BL	28001118	Blue	0700 mA	700 mA	7.15 k Ω	10 pc(s).	0.001 kg
I-SELECT 2 PLUG MAX BL	28001099	Blue	MAX	MAX	0.00 k Ω	10 pc(s).	0.001 kg

Test switch EM2

Accessory



Product description

- _ For connection to the emergency lighting unit
- _ For checking the device function
- _ Dielectric strength: 1,500 V AC for 60 seconds
- _ Lead length 0.55m
- _ Mounting hole 7,0 mm diameter

Website

<http://www.tridonic.com/89805277>



Ordering data

Type	Article number	Packaging, bag	Packaging, carton	Weight per pc.
Test switch EM 2	89805277	25 pc(s).	1,800 pc(s).	0.009 kg

Approval marks

RoHS

Status indication green LED EM

Accessory



Product description

- _ A green LED indicates that charging current is flowing into the battery

Website

<http://www.tridonic.com/89899605>



Ordering data

Type	Article number	Packaging, bag	Packaging, carton	Weight per pc.
LED EM green	89899605	25 pc(s).	200 pc(s).	0.013 kg
LED EM green, ultra high brightness	89899756	25 pc(s).	200 pc(s).	0.013 kg

Approval marks

RoHS

Connection cable LiFePO4

Accessory



Product description

- _ Extension cable for LiFePO4 batteries
- _ Cable length 500 mm
- _ 3-pole plug connection

Website

<http://www.tridonic.com/28002461>



Ordering data

Type	Article number	Packaging, bag	Packaging, carton	Weight per pc.
EXTENSION CABLE LiFePO4 500mm	28002461	10 pc(s).	200 pc(s).	0.011 kg

1. Standards

EN 55015
 EN 60068-2-29
 EN 60068-2-30
 EN 60068-2-64
 EN 61000-3-2
 EN 61000-3-3
 EN 61347-1
 EN 61347-2-7
 EN 61347-2-13
 EN 62384
 EN 61547
 According to EN 50172
 According to EN 60598-2-22

Housing fulfils requirements for reinforced insulation according EN 60598-1.

1.1 Glow wire test

according to EN 61347-1 with increased temperature of 850 °C passed.

2. Thermal details and lifetime

2.1 Expected lifetime

Expected lifetime							
Type	Output current	ta	35 °C	40 °C	45 °C	50 °C	55 °C
	350 mA	tc	60 °C	65 °C	70 °C	75 °C	80 °C
		Lifetime	> 100,000 h	> 100,000 h	> 100,000 h	70,000 h	50,000 h
EM pLED BASIC FX 102 SC LiFePO4 32W	500 mA	tc	65 °C	70 °C	75 °C	80 °C	–
		Lifetime	> 100,000 h	> 100,000 h	70,000 h	50,000 h	–
	700 mA	tc	70 °C	75 °C	80 °C	–	–
		Lifetime	> 100,000	70,000 h	50,000 h	–	–

The relation of tc to ta temperature depends also on the luminaire design. If the measured tc temperature is approx. 5 K below tc max., check the ta temperature and eventually measure critical components (e.g. ELCAP). Detailed information on request.

2.2 Independent use with strain relief set

Ambient temperature:

- ta max (≤ 25 W output power) = 40 °C
- ta max (> 25 W output power) = 35 °C

When used as independent driver with a strain relief set ta max is 10 °C lower compared to the use within a luminaire. This keeps the temperature on any area of the mounting surface within the 90 °C limit and the EM powerLED meets the standards for independent devices.

3. Installation / wiring

3.1 Wiring diagram

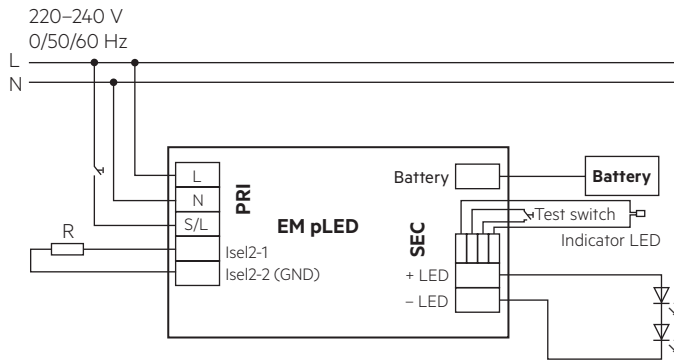

! Recommendation to check glowing at standby in combination with class I luminaires.

3.2 Wiring type and cross section

The wiring can be in stranded wires with ferrules or solid with a cross section of 0.5–1.5 mm² or 0.2–0.5 mm². Strip 8.5 – 9.5 mm or 6 mm of insulation from the cables to ensure perfect operation of the push-wire terminals (depending on connection, see graphics below). Use one wire for each terminal connector only.

LED module/supply

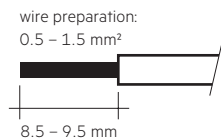

Test switch/Indicator LED

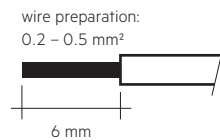

3.3 Loose wiring

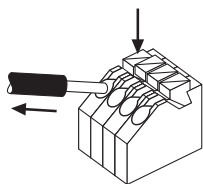

Press down the “push button” and remove the cable from front.

3.4 Fixing conditions when using as independent Driver with Clip-On

Dry, acidfree, oilfree, fatfree. It is not allowed to exceed the maximum ambient temperature (ta) stated on the device. Minimum distances stated below are recommendations and depend on the actual luminaire. Is not suitable for fixing in corner.

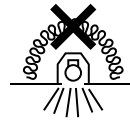
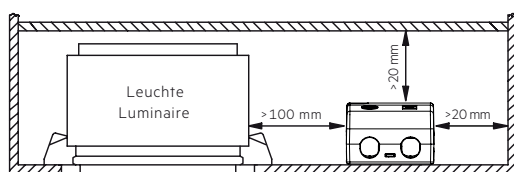

Device not suitable for covering with thermally insulating material according to IEC 60598-1 Ed.9

3.5 Wiring guidelines

- The LED terminals, battery, indicator LED and test switch terminals are classified as SELV (output voltage < 60 V DC). Keep the wiring of the input terminals separated from the wiring of the SELV classified terminals or consider special wiring (double insulation, 5 mm creepage and clearance) when these connections should be kept SELV.
- The output to the LED is DC but has high frequency content, which should be considered for good EMC compliance.
- LED leads should be separated from the mains connections and wiring for good EMC performance.
- Maximum lead length on the LED terminals is 2 m. For a good EMC performance keep the LED wiring as short as possible.
- The secondary wires (LED module) should be routed in parallel to ensure good EMC performance.
- Maximum lead length for the Test switch and Indicator LED connection is 1 m. The test switch and Indicator LED wiring should be separated from the LED leads to prevent noise coupling.
- Battery leads are specified with 0.5 mm cross section and a length of 0.8 m
- To avoid the damage of the control gear, the wiring must be protected against short circuits to earth (sharp edged metal parts, metal cable clips, louver, etc.)

To ensure that a luminaire containing LED emergency units complies with EN 55015 for radio frequency conducted interference in both normal and emergency mode it is essential to follow good practice in the wiring layout.

Within the luminaire the switched and unswitched 50Hz supply wiring must be routed as short as possible and be kept as far away as possible from the LED leads. Through wiring may affect the EMC performance of the luminaire.

The length of LED leads must not be exceeded. Note that the length of the leads from the EM converterLED to the LED modules is added to the length of the leads from the LED Driver to the EM converterLED module when considering the max. permitted lead length of the LED Driver. Leads should always be kept short as possible.

3.6 Hot plug-in

Hot plug-in is not supported due to residual output voltage of > 0 V. If a LED load is connected the device has to be restarted before the output will be activated again. This can be done via mains reset.

3.7 I-SELECT 2 resistors connected via cable

For details see:
http://www.tridonic.com/com/en/download/technical/LCA_PRE_LC_EXC_ProductManual_en.pdf.

4. Electrical values

4.1 Operating window

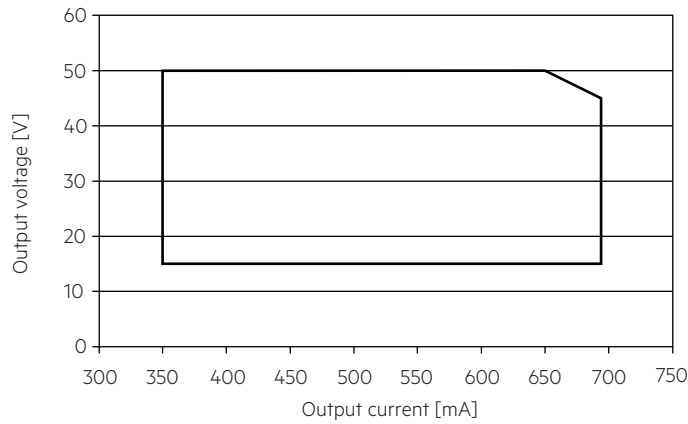

Operate the LED Driver only within the given window under all operating conditions. Coming below the specified minimum output voltage of the LED Driver may cause the device to shut-down.

4.2 Efficiency vs load

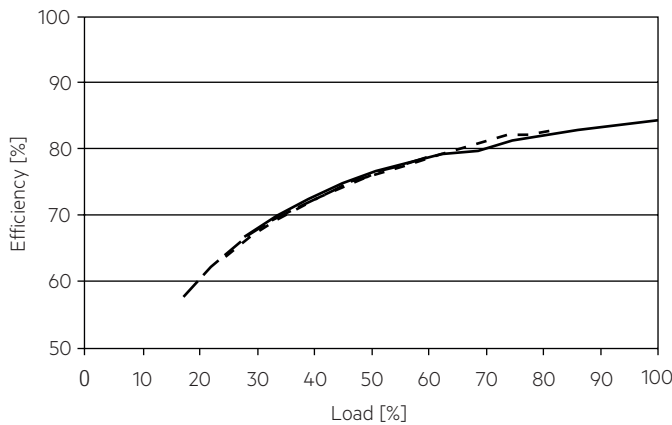

4.3 Power factor vs load

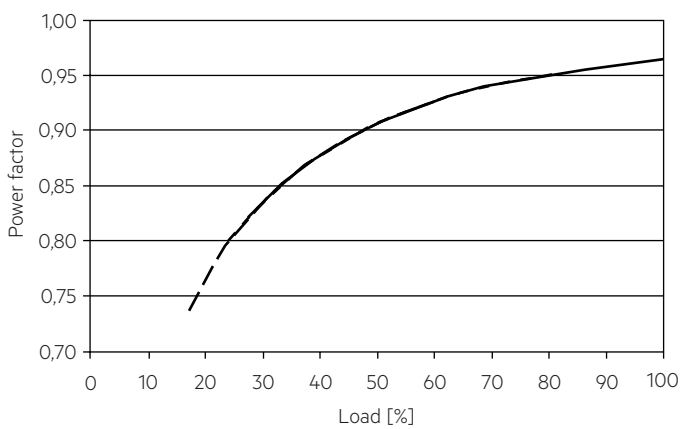

4.4 THD vs load

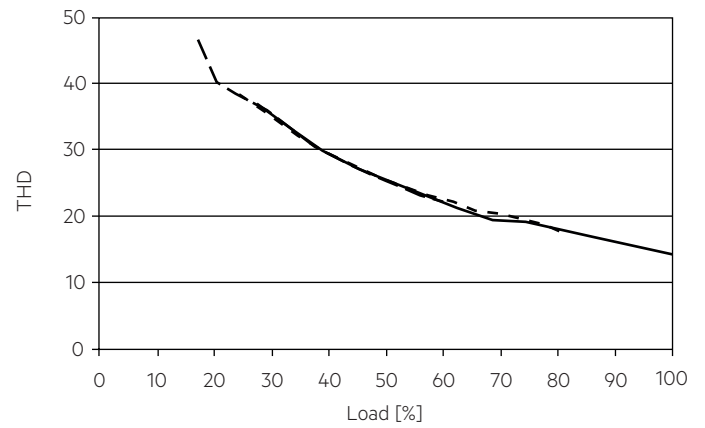

--- 350 mA
 -.- 500 mA
 — 700 mA

100 % load corresponds to the max. output power (full load) according to the table on page 2.

4.5 Maximum loading of automatic circuit breakers

Automatic circuit breaker type	C10	C13	C16	C20	B10	B13	B16	B20	Inrush current	
	Installation Ø	1.5 mm ²	1.5 mm ²	2.5 mm ²	2.5 mm ²	1.5 mm ²	1.5 mm ²	2.5 mm ²	2.5 mm ²	I _{max}
EM pLED BASIC FX 102 SC LiFePO4 32W	35	46	56	73	21	28	34	44	4 A	260 µs

Calculation uses typical values from ABB series S200 as a reference.
Actual values may differ due to used circuit breaker types and installation environment.

4.6 Harmonic distortion in the mains supply (at 230 V / 50 Hz and full load) in %

	THD	3.	5.	7.	9.	11.
EM pLED BASIC FX 102 SC LiFePO4 32W	< 14	< 10	< 3	< 5	< 4	< 1

4.7 Insulation matrix

	Mains	Switched Live	Battery, LED, Test switch, Indicator LED
Mains	–	•	••
Switched Live	•	–	••
Battery, LED, Test switch, Indicator LED	••	••	–

• Represents basic insulation

•• Represents double or reinforced insulation

4.8 Typ. LED current/voltage characteristics

The LED current in emergency mode is automatically adjusted by the EM converterLED module based on the total forward voltage of the LED modules connected and the associated battery. The start of the LED in emergency mode does not result in a current peak.

EM pLED BASIC FX 102 SC LiFePO4 32W
 Article number: 89800687
 LiFePO₄ battery, 3.2 V battery voltage
 880 – 920 mA battery discharge current (tolerance)

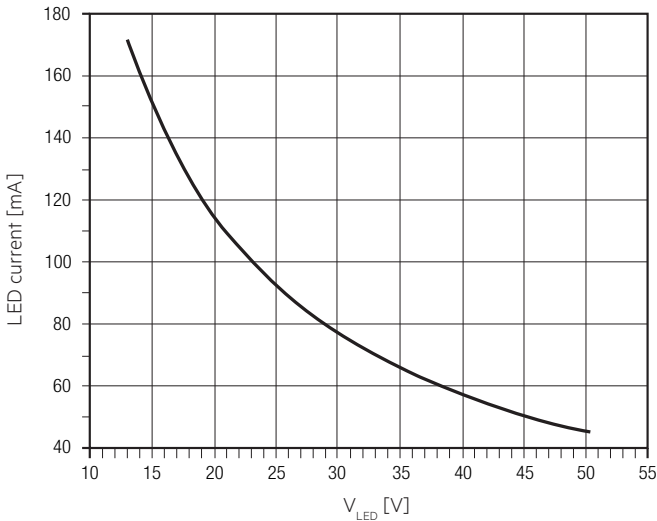

5. Emergency output factor EOFI

EM pLED BASIC

Type	EM pLED BASIC FX 102 SC LiFePO4 32W	
Article no.	89800687	
Cells	1 / 3 cells	
Output current	Min. LED load	Max. LED load
350mA	31.5 %	9.5 %
400mA	26.5 %	8.0 %
450mA	23.0 %	7.0 %
500mA	21.0 %	6.5 %
550mA	19.5 %	6.0 %
600mA	18.0 %	5.0 %
650mA	16.5 %	5.0 %
700mA	15.5 %	4.5 %

6. Mechanical values

6.1 Housing properties

- Casing manufactured from polycarbonate.
- Type of protection: IP20
- Max. torque at the mounting screws: 0.8 Nm

6.2 Mechanical data accessories

LED status indicator

- Green
- Mounting hole 6.5 mm diameter, 1 – 1.6 mm thickness
- Lead length 0.3 m / 1.0 m
- Insulation rating: 90 °C

Test switch

- Mounting hole 7.0 mm diameter
- Lead length 0.55 m

Battery connection

- Plug connection 0.3 m
- Extension 0.5 m

7. Functions

7.1 Status indication LED

System status is indicated by a green LED.

Note:

The status indication LED switches off if the battery does not reach the full capacity (3.6V battery voltage) within 20 – 24 hours. If this occurs disconnect the mains voltage and operate the device in emergency mode for approximately one hour. Afterwards apply the mains voltage again and recharge the battery for 24 hours. If the failure occurs again replace the battery.

7.2 Function: adjustable current

By inserting a suitable resistor or third party resistor into the I-SELECT 2 interface, the current value can be adjusted. The relationship between output current and resistor value can be found in the chapter “Accessories I-SELECT 2 Plugs”.



Please note that the resistor values for I-SELECT 2 are not compatible with I-SELECT (generation 1). Installation of an incorrect resistor may cause irreparable damage to the LED module(s).

Resistors for the main output current values can be ordered from Tridonic (see accessories).

7.3 Short-circuit behaviour

In case of a short-circuit at the LED output the LED output is switched off. After restart of the LED Driver the output will be activated again. The restart can be done via mains reset.

7.4 No-load operation

The LED Driver will not be damaged in no-load operation. The output will be deactivated and is therefore free of voltage. If a LED load is connected the device has to be restarted before the output will be activated again.

8. Battery data

8.1 Battery selection

EM pLED BASIC, 1 / 3 h						
		Type	EM pLED BASIC FX 102 SC LiFePO4 32W			
		Article no.	89800687			
		Duration	1 h	3 h		
Technology and capacity	Design	Capacity	Number of cells	Type	Article no.	Assignable batteries
LiFePO ₄ 18650 cells	stick	1.5 Ah	1 x 1	Accu-LiFePO4 1A CON	28002317	•
	stick	4.5 Ah	1 x 3	Accu-LiFePO4 3A CON	28002320	•
	side by side	4.5 Ah	3 x 1	Accu-LiFePO4 3B CON	28002321	•
	remote box	4.5 Ah	1 x 3	PACK-LiFePO4 4.5Ah 3 CON	28003806	•
	Remote Box	4.5 Ah	1 x 3	PACK-LiFePO4 4.5Ah 3 CON	28005855	•

8.2 Battery charge / discharge data

EM pLED BASIC, 1 / 3 h

		Type	EM pLED BASIC FX 102 SC LiFePO4 32W	
		Article no.	89800687	
		Duration	1 h	3 h
Battery charge time	Initial charge	24 h		
	Trickle charge	continuously and battery voltage controlled		
Charging current	Initial charge	190 – 230 mA	190 – 230 mA	
	Trickle charge ^①	190 – 230 mA / 0 mA	190 – 230 mA / 0 mA	
Discharge current		880 – 920 mA	880 – 920 mA	
Charge voltage range ^②		2.0 – 3.65 V		
Discharge voltage range		3.65 – 2.30 V		

^① Automatic recharge when battery voltage falls below 3.4 V. Charger off (0 mA) when battery voltage exceeds 3.6 V.

Note: Battery protected against operation at excessive temperatures (charging stopped when battery cell temperature < 0 °C or > 60 °C).

The emergency lighting LED Driver will recharge the battery normally after running the test of 61347-2-7 CL 22.3 (abnormal operating conditions).

^② The battery will not be charged below 2.0 V.

8.3 Accu-LiFePO₄

Capacity 1.5 Ah

International designation	IFpR 19/66
Battery voltage/cell	3.2 V
Cell type	18650
Case temperature range to ensure	
5 years design life	+5 °C to +60 °C
7 years design life	+5 °C to +55 °C
10 years design life	+5 °C to +45 °C
12 years design life	+5 °C to +35 °C
Max. short term battery case temperature (shorter than 1 month over the battery lifetime)	70 °C
Max. number discharge cycles	50 cycles total
Max. storage time	15 months at -20 °C to +35 °C

8.4 Accupack-LiFePO₄

Capacity 1.5 Ah

International designation	IFpR 19/66
Battery voltage/cell	3.2 V
Cell type	18650
Case temperature range to ensure	
4 years design life	+5 °C to +45 °C
6 years design life	+5 °C to +35 °C
8 years design life	+5 °C to +25 °C
Max. short term temperature (reduced lifetime)	45 °C
Max. number discharge cycles	50 cycles total
Max. storage time	15 months at -20 °C to +35 °C

Only use Tridonic batteries.

Comply with UN 38.3 and IEC 62133 (safety testing) protected against over charge, over discharge, charging at excessive temperatures, short-circuit and over current.

8.5 Safety



Note: LiFeGuard ensures safe and reliable battery operation by offering a comprehensive three-layered safety system. It addresses the cell, battery pack and emergency driver.

8.5.1 Deep discharge protection

When the battery remains connected without charging for a long period of time after the battery cut off of the driver the battery voltage can still drop. To make sure the cells are not damaged by this voltage drop, the battery protection prevents the battery from further discharge below 2.0 V.

8.5.2 Overcharge protection

If in case of an error or the use of a wrong driver the battery gets overcharged the battery protection will disconnect the battery from the driver at a voltage of 3.9 V. A discharge of the battery is still possible after the protection circuit was triggered to guarantee emergency operation.

8.5.3 Short-circuit protection

In case of a short circuit the battery protection opens the connection to the driver and the output is therefore free of voltage. The output will be reactivated again when the short circuit is removed.

8.5.4 Overtemperature protection

The battery is protected against temporary thermal overheating. If the temperature limit is exceeded the further charging of the battery is no longer possible. The temperature protection is activated below approx. 0 °C and above approx. +60 °C. The discharging of the battery is still possible to guarantee emergency operation. The charging is automatically activated when the temperature is within the range of 0 to 60°C again.



Battery has built in thermal sensor for safe charging. Mount battery away from heat source.

Positioning of the thermal sensor see battery data sheet.

8.6 Wiring batteries

To inhibit inverter operation disconnect the batteries by removing the connection at battery side.

For further informations refer to corresponding battery datasheet.

8.7 Storage, installation and commissioning

Relevant information about storage conditions, installation and commissioning are provided in the battery datasheets.

9. Miscellaneous

9.1 Insulation and electric strength testing of luminaires

Electronic devices can be damaged by high voltage. This has to be considered during the routine testing of the luminaires in production.

According to IEC 60598-1 Annex Q (informative only!) or ENEC 303-Annex A, each luminaire should be submitted to an insulation test with 500 V_{DC} for 1 second. This test voltage should be connected between the interconnected phase and neutral terminals and the earth terminal. The insulation resistance must be at least 2 MΩ.

As an alternative, IEC 60598-1 Annex Q describes a test of the electrical strength with 1500 V_{AC} (or 1.414 x 1500 V_{DC}). To avoid damage to the electronic devices this test must not be conducted.

9.2 Conditions of use and storage

Humidity: 5% up to max. 85%,
not condensed
(max. 56 days/year at 85%)

Storage temperature: -40 °C up to max. +80 °C

The devices have to be acclimatised to the specified temperature range (ta) before they can be operated.

9.3 Maximum number of switching cycles

All Emergency LED Driver are tested with 50,000 switching cycles in maintained mode. The actually achieved number of switching cycles is significantly higher.

9.4 Additional information

Additional technical information at www.tridonic.com → Technical Data

Lifetime declarations are informative and represent no warranty claim. No warranty if device was opened.