

EM converterPACK ST 60 V UNV WIRE

SELFTEST version (US applications)



Product description

- _ Emergency lighting LED driver with selftest function
- _ Only for US applications
- _ Battery pack enclosed
- _ For self-contained emergency lighting
- _ For LED modules with a forward voltage up to 57 V
- _ Class 2
- _ UL certified
- _ EM = Emergency
- _ 5 years guarantee (conditions at <https://www.tridonic.com/manufacture-guarantee-conditions>)

Properties

- _ Non maintained operation
- _ Self-test
- _ 90 minutes rated duration
- _ Compatible with most constant current LED drivers (see data sheet, LED driver compatibility)
- _ 3-pole technology: 2-pole LED module changeover and delayed power switching for the LED driver
- _ Automatic shutdown of output if LED load is out of range
- _ Constant power output
- _ Combined status display LED and test switch
- _ Electronic charge system
- _ Deep discharge protection
- _ Short-circuit-proof battery connection
- _ Polarity reversal protection for battery
- Self-test:
 - _ Status of the battery
 - _ Status of the LED
 - _ Function test
 - _ Duration test

Batteries

- _ High-temperature cells
- _ NiMH batteries
- _ 5 years guarantee for NiMH batteries (conditions at <https://www.tridonic.com/manufacture-guarantee-conditions>)

Website

<http://www.tridonic.com/28002864>



EM converterPACK ST 60 V UNV WIRE

SELFTTEST version (US applications)

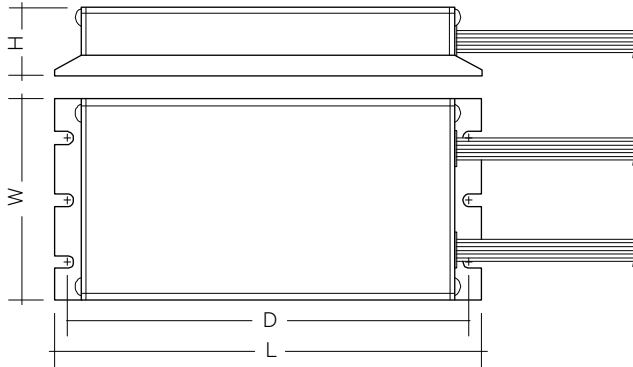

Ordering data

Type	Article number	Rated duration	Packaging, carton	Packaging, pallet	Weight per pc.	Hole spacing D	Dimensions L x W x H
EM converterPACK ST 1-9-5 60V UNV WIRE	28002864	1.5 h	16 pc(s).	960 pc(s).	0.63 kg	252 mm	260 x 65 x 22 mm
EM converterPACK ST 1-9-9 60V UNV WIRE	28002867	1.5 h	16 pc(s).	1,008 pc(s).	0.78 kg	299 mm	307 x 65 x 22 mm
EM converterPACK ST 1-9-15 60V UNV WIRE	28002870	1.5 h	12 pc(s).	720 pc(s).	1.08 kg	364 mm	372 x 65 x 22 mm

Technical data

Rated supply voltage	120 – 277 V
Mains frequency	50 / 60 Hz
Typ. λ	0.5C
Output current	Refer to data sheet
Starting time	< 0.25 s from detection of emergency event
Overvoltage protection	305 V
U-OUT (including open- / short-circuit and double load)	60 V
Max. open circuit voltage	60 V
Ambient temperature ta	0 ... +50 °C
Max. casing temperature tc	70 °C
Mains voltage changeover threshold emergency mode	30 V
Mains voltage changeover threshold mains mode	70 V
Type of protection	IP20
Functional test	Monthly 30 s test
Duration test	Yearly 90 minutes test
Lifetime	50,000 h

Approval marks



Standards

UL 924, FCC PART 15, ICES-005

Specific technical data

Type	Mains voltage	LED module forward voltage range	Typ. output power P emergency	Mains current in charging operation			Mains power in charging operation		
				Initial charge	Fast recharge	Trickle charge	Initial charge	Fast recharge	Trickle charge
EM converterPACK ST 1-9-5 60V UNV WIRE	120 V	13 – 57 V	5 W	40 mA	36 mA	5.1 mA	2.1 W	1.8 W	0.5 W
EM converterPACK ST 1-9-5 60V UNV WIRE	277 V	13 – 57 V	5 W	25 mA	22 mA	3.7 mA	2.5 W	2.0 W	0.5 W
EM converterPACK ST 1-9-9 60V UNV WIRE	120 V	14 – 57 V	9 W	51 mA	50 mA	5.9 mA	2.9 W	2.8 W	0.5 W
EM converterPACK ST 1-9-9 60V UNV WIRE	277 V	14 – 57 V	9 W	30 mA	29 mA	4.2 mA	3.2 W	2.8 W	0.6 W
EM converterPACK ST 1-9-15 60V UNV WIRE	120 V	15 – 57 V	15 W	62 mA	68 mA	6.9 mA	3.9 W	3.9 W	0.6 W
EM converterPACK ST 1-9-15 60V UNV WIRE	277 V	15 – 57 V	15 W	38 mA	39 mA	4.8 mA	4.0 W	4.0 W	0.6 W

1. Standards

UL 924
 FCC Part 15, Class A
 ICES-005

Product not designed for European Economic Area.

This device complies with Part 15 of the FCC Rules. Operation is subject to the following two conditions:

- (1) this device may not cause harmful interference, and
- (2) this device must accept any interference received, including interference that may cause undesired operation.

2. Thermal details and lifetime

2.1 Lifetime

Average lifetime 50,000 hours under rated conditions with a failure rate of less than 10 %. Average failure rate of 0.2% per 1000 operating hours.

Expected lifetime

Type	ta	40 °C	50 °C	55 °C	60 °C
EM converterPACK ST 1-9-x 60V UNV WIRE	tc	55 °C	65 °C	70 °C	75 °C
	lifetime	65,000 h	55,000 h	50,000 h	45,000 h

The emergency lighting LED Driver is designed for a lifetime stated above under reference conditions and with a failure probability of less than 10 %.

The relation of tc to ta temperature depends also on the luminaire design. If the measured tc temperature is approx. 5 K below tc max., ta temperature should be checked and eventually critical components (e.g. ELCAP) measured. Detailed information on request.

3. Installation / Wiring

3.1 Wiring diagram

One or more LED modules with a total forward voltage in the forward voltage range of the EM converterPACK can be connected. These LED module(s), marked with “Emergency” are operated in emergency mode from the associated battery. In normal mains mode all LED modules are operated by the mains LED Driver.

EM converterPACK SELFTEST with one LED module for mains and emergency operation

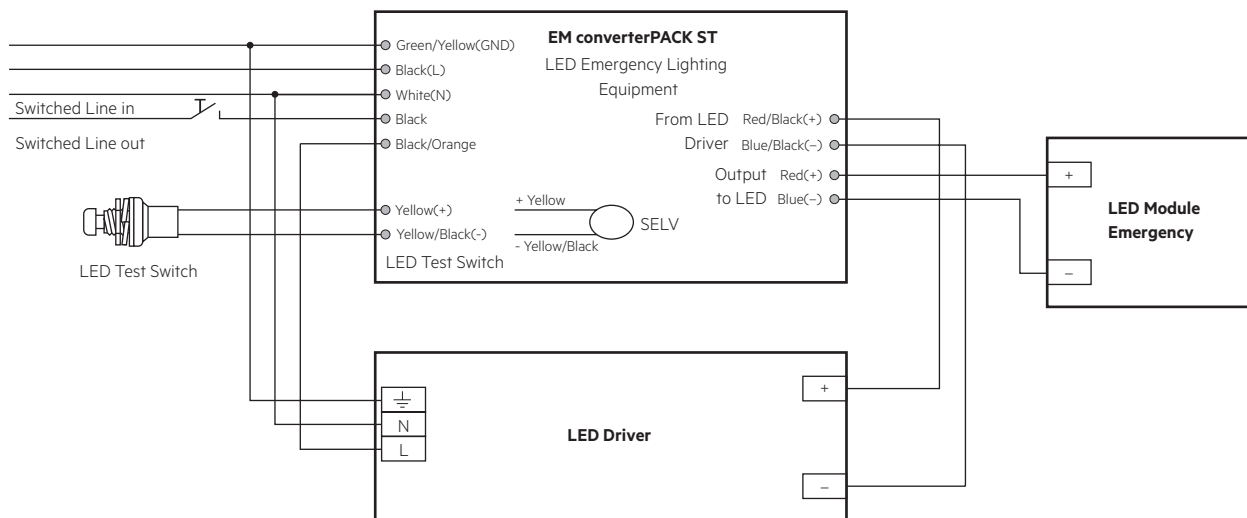

3.2 Wiring type and cross section

	Solid / Stranded	Cross section
Earth	Solid	0.5 – 1.5 mm ²
L	Solid	0.5 – 1.5 mm ²
N	Solid	0.5 – 1.5 mm ²
Live in	Stranded	0.5 – 1.5 mm ²
Live out	Stranded	0.5 – 1.5 mm ²
Test switch +	Stranded	0.5 – 1.5 mm ²
Test switch -	Stranded	0.5 – 1.5 mm ²
LED driver +	Solid	0.5 – 1.5 mm ²
LED driver -	Solid	0.5 – 1.5 mm ²
LED +	Solid	0.5 – 1.5 mm ²
LED -	Solid	0.5 – 1.5 mm ²
Battery +	Stranded	0.5 - 1.5 mm ²
Battery -	Stranded	0.5 - 1.5 mm ²

3.3 Wiring guidelines

- For good EMC compliance consider that the output to the LED is DC but has high frequency content.
- Separate LED leads from the mains connection and wiring for good EMC performance.
- Keep the LED wiring as short as possible for a good EMC performance.
- Route the secondary wires (LED module) in parallel to ensure good EMC performance.
- Maximum lead length for the LED test switch connection is 250 mm / 9.84 inch. Separate the LED test switch wiring from the LED leads to prevent noise coupling.
- To avoid the damage of the control gear, the wiring must be protected against short circuits to earth (sharp edged metal parts, metal cable clips, louver, etc.).

3.4 Maximum lead length

LED test switch 250 mm

3.5 Use of different phases

The use of different phases for switched line and unswitched line is prohibited.

4. Mechanical values

4.1 Housing properties

- Casing manufactured from metal.
- Type of protection: IP20
- The housing incorporates DIP switches. The position of the DIP switches is essential for the correct operation and must not be changed. Altering their position will prohibit the correct operation of the emergency lighting LED Driver.

4.2 Mechanical data accessories

LED test switch

- Mounting hole 4.2 mm diameter
- Mounting hole strength < 5 mm
- Lead length 250 mm
- For direct installation or use in a separate junction box

5. Electrical values

5.1 Typ. LED current/voltage characteristics

The LED current in emergency mode is automatically adjusted by the EM converterPACK module based on the total forward voltage of the LED modules connected and the associated battery. The start of the LED in emergency mode does not result in a current peak.

EM converterPACK ST 1-9-5 60V UNV WIRE

Article number: 28002864

NiMH battery, 9.6 V battery voltage

540 – 630 mA battery discharge current (tolerance)

EM converterPACK ST 1-9-9 60V UNV WIRE

Article number: 28002867

NiMH battery, 10.8 V battery voltage

860 – 1,150 mA battery discharge current (tolerance)

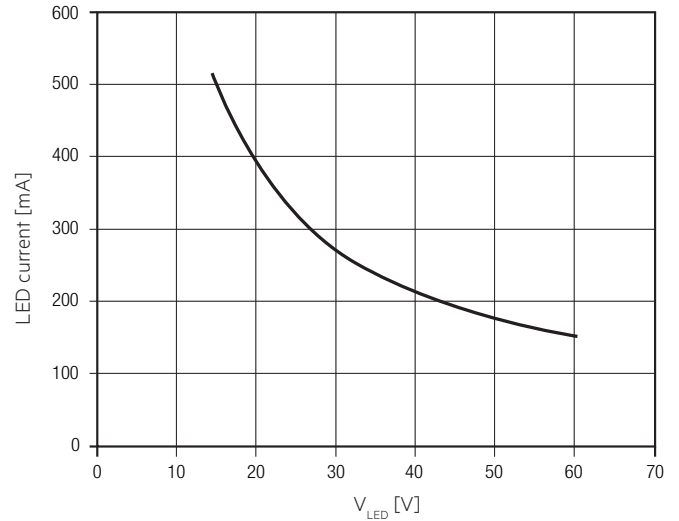
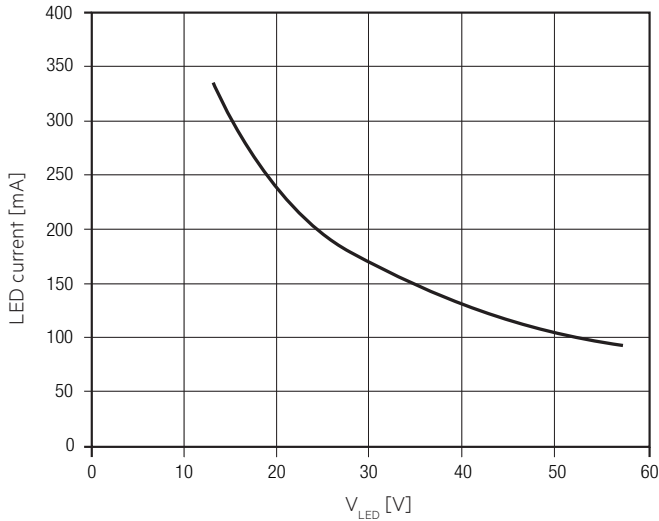

EM converterPACK ST 1-9-15 60V UNV WIRE

Article number: 28002870

NiMH battery, 10.8 V battery voltage

1,410 – 1,720 mA battery discharge current (tolerance)

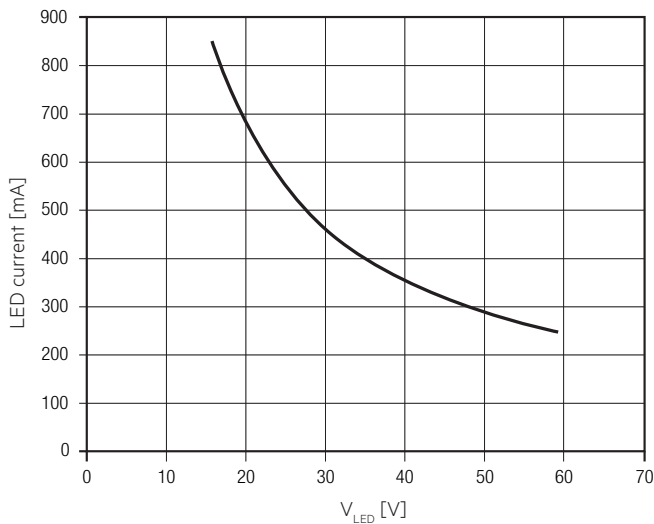

5.2 LED Driver compatibility

The EM converterPACK emergency unit use 3 pole technology and is compatible with most LED Drivers on the market, however it is important to check that the rating of the LED Driver does not exceed the values specified below:

- The max. allowed output current rating of the associated LED Driver is 5 A peak (Current rating of switching relays of EM converterPACK)
- The max. allowed output voltage of the associated LED Driver applied to the EM converterPACK output is 60V (voltage withstand between adjacent contact of the single switching relay of the EM converterPACK)
- The max. allowed LED load of the associated LED Driver is 300 W in operation. The load must be an LED module.

6. Functions**6.1 Status indication**

System status is indicated by LED test switch.

LED indication	Status	Comment
Permanent on	System OK	AC mode
Slow flashing (2 sec on – 2 sec off)	Charging	Battery not yet fully charged
Fast flashing (0.5 sec on – 0.5 sec off)	Battery failure	Battery failed the duration test or function test / Battery is defect or deep discharged/ Incorrect battery voltage
Gradual change	Test underway	Function or duration test

6.2 Commissioning

After installation of the luminaire and initial connection of the mains supply and battery supply to the EM converterPACK ST the unit will commence charging the batteries for the initial charge time.

The recharge occurs also if a new battery is connected.

The following automatic commissioning duration test is only performed when a battery is replaced and fully charged.

6.3 Testing**Functional test**

Functional tests are carried out for 30 seconds on a monthly basis under the control of the Micro controller. Initiation and timing of these tests is set during the commissioning of the luminaire.

Duration test

A full duration test is carried out yearly to check the capacity of the batteries.

LED test switch

LED test switch can be wired to each EM converterPACK ST.

This can be used to:

- Initiate a 30 seconds function test: press two times within 5 s
- Initiate a duration test: press 3 times within 5 s

7. Battery data

7.1 Battery charge / discharge data

EM converterPACK ST 1-9-x 60V UNV

Type	EM converterPACK ST 1-9-5 60V UNV WIRE	EM converterPACK ST 1-9-9 60V UNV WIRE	EM converterPACK ST 1-9-15 60V UNV WIRE	
Article no.	28002864	28002867	28002870	
Battery charge time	Initial charge		24 h	
	Fast recharge		24 h	
	Trickle charge			continuously
Charging current	Initial charge	119 mA	153 mA	210 mA
	Fast recharge	90 mA	110 mA	190 mA
	Trickle charge	75 mA	105 mA	190 mA
Discharge current	0.35 C	0.45 C	0.45 C	

7.2 Technical data batteries

Type	EM converterPACK ST 1-9-5 60V UNV WIRE	EM converterPACK ST 1-9-9 60V UNV WIRE	EM converterPACK ST 1-9-15 60V UNV WIRE
Article no.	28002864	28002867	28002870
Voltage	9.6 V	10.8 V	10.8 V
Capacity	1,500 mAh	2,100 mAh	3,800 mAh
Discharge cycles	500	500	500

8. Miscellaneous

8.1 Maximum number of switching cycles

EM converterLEDs are tested with 10,000 mains switching cycles of the associated LED driver.

8.2 Additional information

Additional technical information at www.tridonic.com → Technical Data

Guarantee conditions at www.tridonic.com → Services

Lifetime declarations are informative and represent no warranty claim.
No warranty if device was opened.