

EM converterLED ST NiCd/NiMH 250 V

SELFTEST version

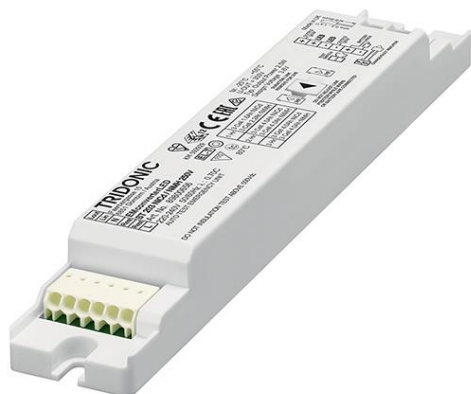

**Product description**

- \_ Self-contained emergency lighting LED driver with self-test function
- \_ Non maintained operation
- \_ For LED modules with a forward voltage of 48 – 250 V
- \_ For luminaire installation
- \_ EM = Emergency
- \_ Nominal lifetime up to 100,000 h
- \_ 5 years guarantee (Conditions at <https://www.tridonic.com/en/int/services/manufacture-guarantee-conditions>)

**Functions**

- \_ 1, 2 or 3 h rated duration selectable with duration link
- \_ Constant power output
- \_ Self-test:
  - \_ Weekly function test
  - \_ Yearly duration test

**Driver compatibility**

- \_ 3-pole technology: 2-pole LED module changeover and delayed power switching for the LED driver
- \_ For further information see data sheet, LED driver compatibility

**Battery management**

- \_ Intelligent charge system
- \_ Deep discharge protection
- \_ Polarity reversal protection for battery

**Batteries**

- \_ NiCd or NiMH batteries
- \_ 4 year design life
- \_ 2 years guarantee (Conditions at <https://www.tridonic.com/en/int/services/manufacture-guarantee-conditions>)
- \_ For battery compatibility refer to data sheet, battery selection

**Website**

<http://www.tridonic.com/89800656>



## EM converterLED ST NiCd/NiMH 250 V

SELFTEST version

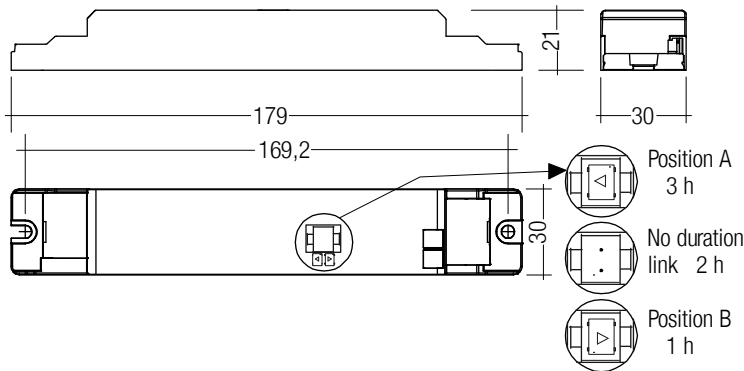

Note: LED driver supplied with duration link in 3 hours position. Duration link must be set before battery and mains connection.

## Ordering data

Type	Article number	Rated duration	Packaging, carton	Packaging, pallet	Weight per pc.	Dimensions L x W x H
EM converterLED ST 203 NiCd/NiMH 250V	89800656	1/2/3 h	10 pc(s).	1,600 pc(s).	0.073 kg	179 x 30 x 21 mm
EM converterLED ST 204 NiCd/NiMH 250V	89800657	1/2/3 h	10 pc(s).	1,600 pc(s).	0.073 kg	179 x 30 x 21 mm
EM converterLED ST 205 NiCd/NiMH 250V	89800658	1/2/3 h	10 pc(s).	1,600 pc(s).	0.073 kg	179 x 30 x 21 mm

## Technical data

Rated supply voltage	220 – 240 V
AC voltage range	198 – 264 V
Mains frequency	50 / 60 Hz
Forward voltage range LED module	48 – 250 V
Output current	Refer to data sheet
Starting time	< 0.5 s from detection of emergency event
Overvoltage protection	320 V (for 48 h)
U-OUT (including open- / short-circuit and double load)	300 V
Max. open circuit voltage	300 V
Ambient temperature $t_a$	-25 ... +55 °C
Max. casing temperature $t_c$	80 °C
Mains voltage changeover threshold	According to EN 60598-2-22
Mains surge capability (between L - N)	1 kV
Mains surge capability (between L/N - PE)	2 kV
Type of protection	IP20
Rest mode max. number of emergency units	100
Rest mode max. wiring distance	1,000 m
Functional test	Weekly 5s test
Duration test	Yearly 1 h / 2 h / 3 h test
Lifetime	up to 100,000 h
Guarantee (conditions at <a href="http://www.tridonic.com">www.tridonic.com</a> )	5 Year(s)
Dimensions L x W x H	179 x 30 x 21 mm

## Approval marks



## Standards

EN 61347-1, EN 61347-2-13, EN 61347-2-7, EN 55015, EN 61000-3-2, EN 61000-3-3, EN 61547, EN 60068-2-64, EN 60068-2-29, EN 60068-2-30, EN 62384, according to EN 50172, according to EN 60598-2-22, acc. to EN 62034

## Specific technical data

Type	Rated duration	Typ. $\lambda$ (at 230 V, 50 Hz)	Typ. output power P <sub>emergency</sub>	Mains current in charging operation			Mains power in charging operation		
				Initial charge	Fast recharge	Trickle charge	Initial charge	Fast recharge	Trickle charge
EM converterLED ST 203 NiCd/NiMH 250V	1 h	0.6C	2.5 W	16 mA	18 mA	13 mA	2.1 W	2.6 W	1.9 W
EM converterLED ST 203 NiCd/NiMH 250V	2 h	0.7C	2.5 W	20 mA	21 mA	16 mA	3.1 W	3.1 W	2.4 W
EM converterLED ST 203 NiCd/NiMH 250V	3 h	0.7C	2.5 W	20 mA	21 mA	16 mA	3.1 W	3.1 W	2.4 W
EM converterLED ST 204 NiCd/NiMH 250V	1 h	0.6C	3.5 W	17 mA	20 mA	14 mA	2.3 W	2.9 W	2.0 W
EM converterLED ST 204 NiCd/NiMH 250V	2 h	0.7C	3.5 W	23 mA	24 mA	17 mA	3.6 W	3.6 W	2.6 W
EM converterLED ST 204 NiCd/NiMH 250V	3 h	0.7C	3.5 W	23 mA	24 mA	17 mA	3.6 W	3.6 W	2.6 W
EM converterLED ST 205 NiCd/NiMH 250V	1 h	0.6C	4.5 W	18 mA	22 mA	15 mA	2.6 W	3.2 W	2.0 W
EM converterLED ST 205 NiCd/NiMH 250V	2 h	0.7C	4.5 W	25 mA	26 mA	18 mA	4.1 W	4.1 W	2.8 W
EM converterLED ST 205 NiCd/NiMH 250V	3 h	0.7C	4.5 W	25 mA	26 mA	18 mA	4.1 W	4.1 W	2.8 W

EMcLED Strain-relief set 240x43x30mm

Accessory

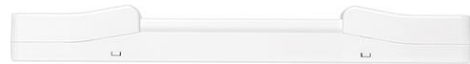

**Product description**

- \_ Optional strain-relief for independent applications
- \_ Transforms the LED driver into a fully class II compatible LED driver (e.g. ceiling installation)
- \_ Easy and tool-free mounting to the LED driver, screwless cable-clamp channels with strain-relief (240 x 43 x 30 mm)

**Website**

<http://www.tridonic.com/28003813>



## Emergency lighting units

EM converterLED

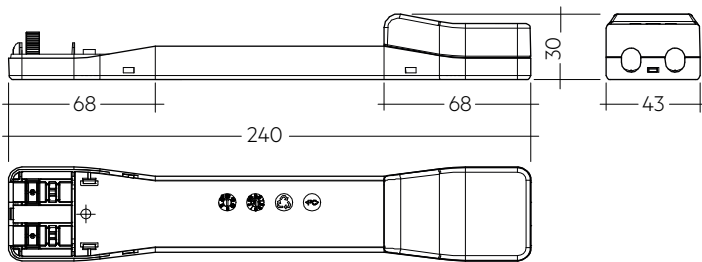

Permissible cable jacket diameter 2.2 – 9 mm

### Ordering data

Type	Article number	Packaging, carton	Weight per pc.
EM cLED SR	28003813	10 pc(s).	0.08 kg

### Approval marks



## Test switch EM3

Accessory



### Product description

- \_ For connection to the emergency lighting unit
- \_ For checking the device function
- \_ Plug connection
- \_ Dielectric strength: 1,500 V AC for 60 seconds
- \_ Lead length 0.55m
- \_ Mounting hole 7,0 mm diameter

### Website

<http://www.tridonic.com/89899956>



### Ordering data

Type	Article number	Packaging, bag	Packaging, carton	Weight per pc.
Test switch EM 3	89899956	25 pc(s).	2,000 pc(s).	0.01 kg

### Approval marks

RoHS

## Status indication bi-colour LED EM CON

Accessory



## Product description

- \_ Two-colour status display LED
- \_ Green: system OK, red: fault
- \_ Plug connection

## Website

<http://www.tridonic.com/89800273>



## Ordering data

Type	Article number	Packaging, bag	Packaging, carton	Weight per pc.
LED EM bi-colour, 1.0 m CON	<b>89800273</b>	25 pc(s).	200 pc(s).	0.016 kg
LED EM bi-colour, high brightness HO 1.0 m CON	<b>89800275</b>	25 pc(s).	200 pc(s).	0.016 kg
LED EM bi-colour, 0.6 m CON	<b>89800474</b>	25 pc(s).	200 pc(s).	0.010 kg
LED EM bi-colour, high brightness HO 0.6 m CON	<b>89800475</b>	25 pc(s).	200 pc(s).	0.011 kg
LED EM bi-colour, 0.3 m CON	<b>89800274</b>	25 pc(s).	200 pc(s).	0.007 kg
LED EM bi-colour, high brightness HO 0.3 m CON	<b>89800276</b>	25 pc(s).	200 pc(s).	0.007 kg

## 1. Standards

- EN 61347-1
- EN 61347-2-13
- EN 61347-2-7
- EN 55015
- EN 61000-3-2
- EN 61000-3-3
- EN 61547
- EN 60068-2-64
- EN 60068-2-29
- EN 60068-2-30
- EN 62384
- according to EN 50172
- according to EN 60598-2-22
- according to EN 62034

Meaning of marking 

Double or reinforced insulation for built-in electronic LED drivers. The control gear relies upon the luminaire enclosure for protection against accidental contact with live parts.

### 1.1 Glow-wire test

according to EN 61347-1 with increased temperature of 850 °C passed.

### 1.2 Insulation and electric strength testing of luminaires

Electronic LED-drivers can be damaged by high voltage. This has to be considered during the routine testing of the luminaires in production.

According to IEC 60598-1 Annex Q (informative only!) or ENEC 303-Annex A, each luminaire should be submitted to an insulation test with 500 V<sub>DC</sub> for 1 second. This test voltage should be connected between the interconnected phase and neutral terminals and the earth terminal. The insulation resistance must be at least 2 MΩ.

As an alternative, IEC 60598-1 Annex Q describes a test of the electrical strength with 1,500 V<sub>AC</sub> (or 1,414 x 1,500 V<sub>DC</sub>). To avoid damage to the electronic devices this test **must not be conducted**.

## 2. Thermal details and lifetime

### 2.1 Lifetime

Average lifetime 50,000 hours under rated conditions with a failure rate of less than 10 %. Average failure rate of 0.2 % per 1000 operating hours.

#### Expected lifetime

<b>EM converterLED ST 203</b>	tc	65 °C	70 °C	75 °C	80 °C
<b>NiCd/NiMH 250V</b>	lifetime	> 100,000 h	> 100,000 h	78,000 h	55,000 h
<b>EM converterLED ST 204</b>	tc	65 °C	70 °C	75 °C	80 °C
<b>NiCd/NiMH 250V</b>	lifetime	> 100,000 h	> 100,000 h	77,000 h	55,000 h
<b>EM converterLED ST 205</b>	tc	65 °C	70 °C	75 °C	80 °C
<b>NiCd/NiMH 250V</b>	lifetime	> 100,000 h	> 100,000 h	74,000 h	53,000 h

The emergency lighting LED driver is designed for a lifetime stated above under reference conditions and with a failure probability of less than 10 %.

The relation of tc to ta temperature depends also on the luminaire design. If the measured tc temperature is approx. 5 K below tc max., ta temperature should be checked and eventually critical components (e.g. ELCAP) measured. Detailed information on request.

## 3. Installation / Wiring

### 3.1 Wiring diagram

One or more LED modules with a total forward voltage of 48 to 250 V can be connected to the EM converterLED module. These LED module(s), marked with "Emergency" are operated in emergency mode from the associated battery. In normal mains mode all LED modules are operated by the mains LED driver.

**EM converterLED SELFTEST with one LED module for non-maintained emergency operation**

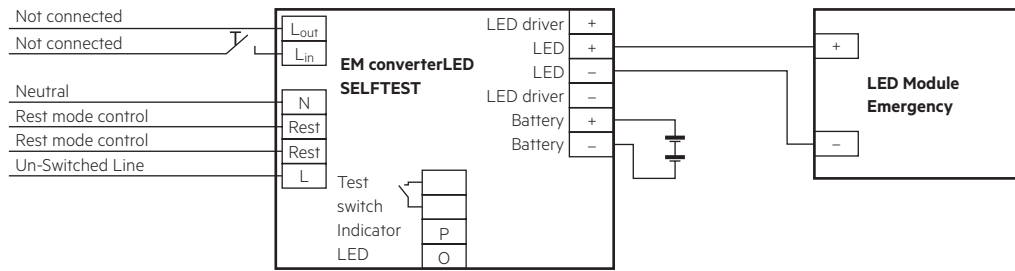

**EM converterLED SELFTEST with a standard LED driver and one LED module for mains and emergency operation**

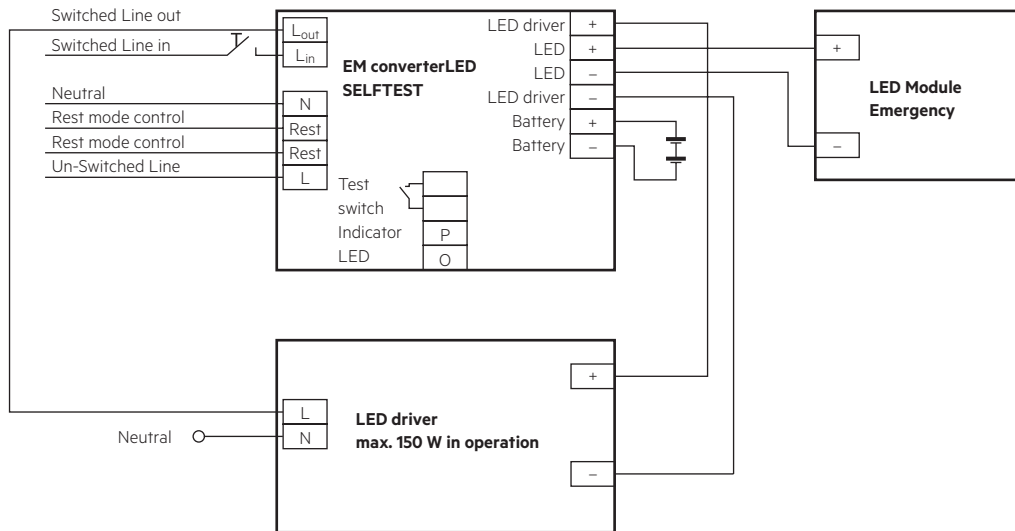

**EM converterLED SELFTEST with a standard LED driver and series operation of LED modules**

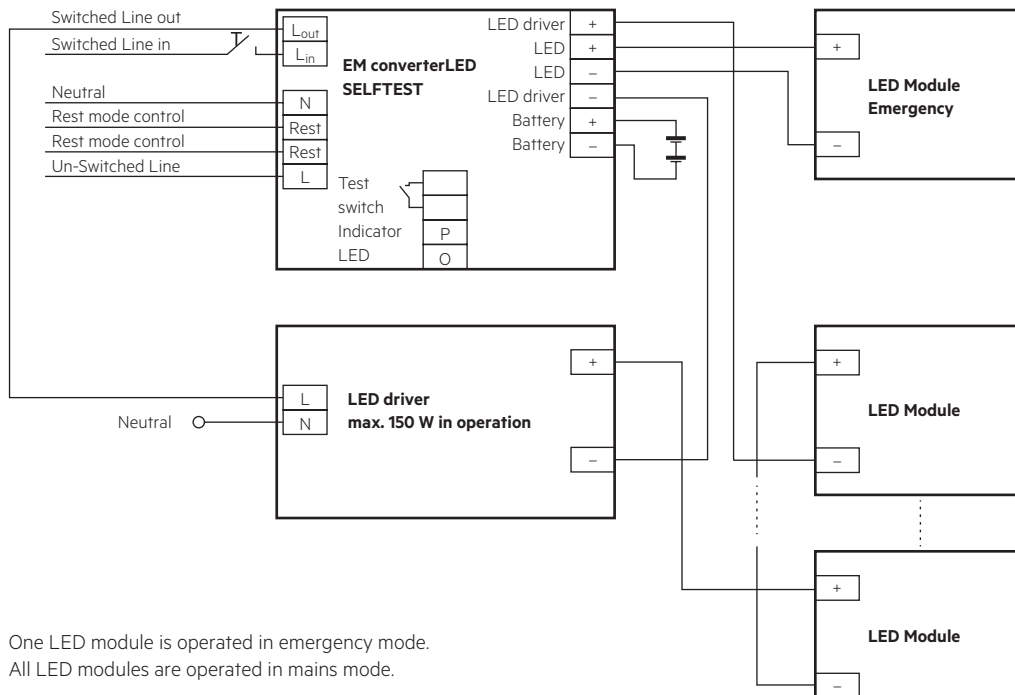

One LED module is operated in emergency mode.  
All LED modules are operated in mains mode.

**EM converterLED SELFTEST with a standard LED driver and parallel operation of LED modules**

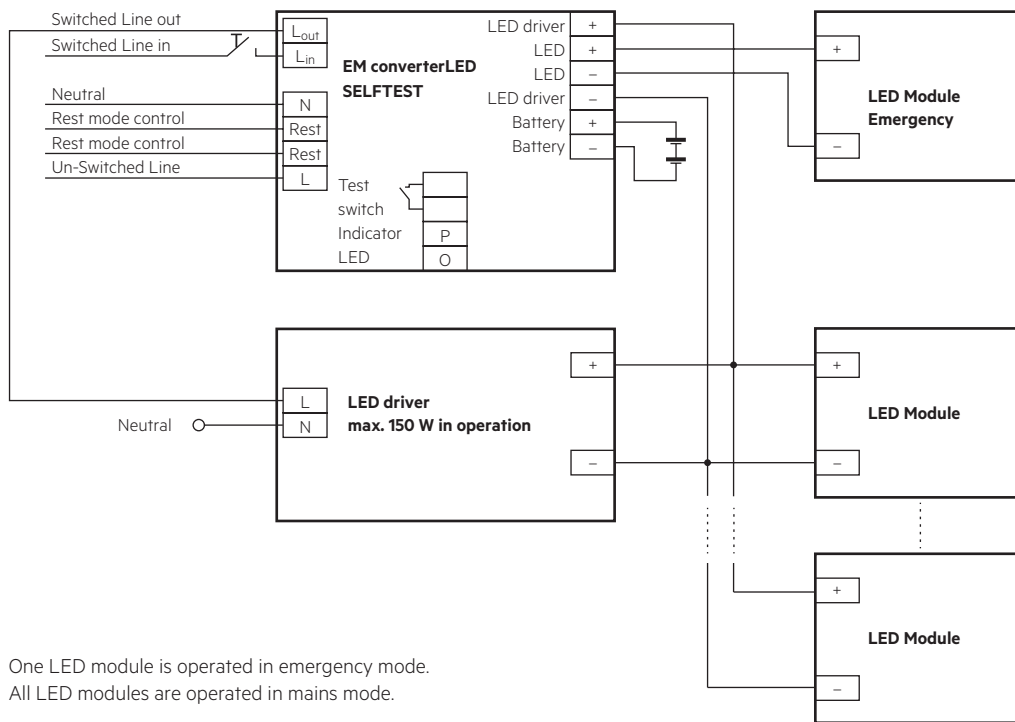

One LED module is operated in emergency mode.  
All LED modules are operated in mains mode.

**3.2 Wiring type and cross section**

Solid wire with a cross section of 0.5 – 1.5 mm<sup>2</sup>. Strip 8 – 9 mm of insulation from the cables to ensure perfect operation of terminals.

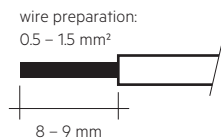

**3.3 Loose wiring**

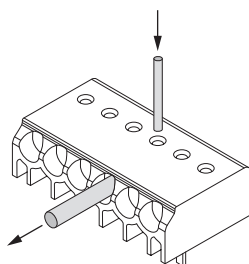

Loosen wire through twisting and pulling or using a Ø 1 mm release tool

**3.4 Wiring guidelines**

- The output to the LED is DC but has high frequency content, which should be considered for good EMC compliance.
- Separate LED leads from the mains and REST connections and wiring for good EMC performance.
- Maximum lead length on the LED terminals is 3 m. For a good EMC performance keep the LED wiring as short as possible.
- Route the secondary wires (LED module) in parallel to ensure good EMC performance.

- Maximum lead length for the Test switch and Indicator LED connection is 1 m. Separate the test switch and Indicator LED wiring from the LED leads to prevent noise coupling.
- Battery leads are specified with 0.5 mm cross section and a length of 0.8 m
- REST terminals are mains proof.
- Protect the wiring against short circuits to earth (sharp edged metal parts, metal cable clips, louver, etc.) to avoid the damage of the control gear.

To ensure that a luminaire containing LED emergency units complies with EN 55015 for radio frequency conducted interference in both normal and emergency mode it is essential to follow good practice in the wiring layout.

Within the luminaire route the switched and unswitched 50Hz supply wiring as short as possible and keep it as far away as possible from the LED leads. Through wiring may affect the EMC performance of the luminaire.

Do not exceed the max. length of LED leads to the LED module. Note that the length of the EM converterLED leads to the LED module is added to the length of the leads from the LED driver to the EM converterLED module when considering the max. permitted lead length of the LED driver.

**3.5 Maximum lead length**

LED	3 m <sup>①</sup>
Status indication LED	1 m
Batteries	1 m

<sup>①</sup> Note: The length of LED leads to the LED module must not be exceeded. Note that the length of the EM converterLED leads is added to the length of the leads from the LED driver to the EM converterLED module when considering max. permitted lead length of the LED driver. Leads should always be kept as short as possible.

### 3.6 Use of different phases

The use of different phases for switched line and unswitched line is allowed. When using different phases, the unswitched line must fail if the switched line fails. This is required to assure correct switching into emergency mode. It can be realised with a relay.

## 4. Mechanical values

### 4.1 Housing properties

- Casing manufactured from polycarbonate.
- Type of protection: IP20

### 4.2 Mechanical data accessories

LED status indicator

- Bi-colour
- Mounting hole 6.5 mm diameter, 1 – 1.6 mm thickness
- Lead length 0.3 m / 1.0 m
- Insulation rating: 90 °C
- Plug connection

Test switch

- Mounting hole 7.0 mm diameter
- Lead length 0.55 m
- Plug connection

Battery connection

- Plug connection 0.3 m
- Extension 0.5 m

## 5. Electrical values

### 5.1 Maximum loading of automatic circuit breakers

Automatic circuit breaker type	B10	B13	B16	B20	C10	C13	C16	C20	Inrush current	
Installation Ø	1.5 mm <sup>2</sup>	1.5 mm <sup>2</sup>	1.5 mm <sup>2</sup>	2.5 mm <sup>2</sup>	1.5 mm <sup>2</sup>	1.5 mm <sup>2</sup>	1.5 mm <sup>2</sup>	2.5 mm <sup>2</sup>	I <sub>max</sub>	time
<b>EM converterLED ST NiCd/NiMH 250V</b>	90	130	130	130	180	260	260	260	10 A	120 µs

### 5.2 Insulation matrix

	Mains	Switched Live	Battery, LED, Test switch, Indicator LED	REST	LED driver
Mains	–	•	••	•	•
Switched Live	•	–	••	•	•
Battery, LED, Test switch, Indicator LED	••	••	–	•	•
REST	•	•	•	–	•
LED driver	•	•	–	•	–

- Represents basic insulation
- Represents double or reinforced insulation

When using a non-SELV LED driver insulate the battery, LED, test switch and indicator LED in the luminaire according to the U-OUT rating of the LED driver.

5.3 Typ. LED current/voltage characteristics

The LED current in emergency mode is automatically adjusted by the EM converterLED module based on the total forward voltage of the LED modules connected and the associated battery. The start of the LED in emergency mode does not result in a current peak.

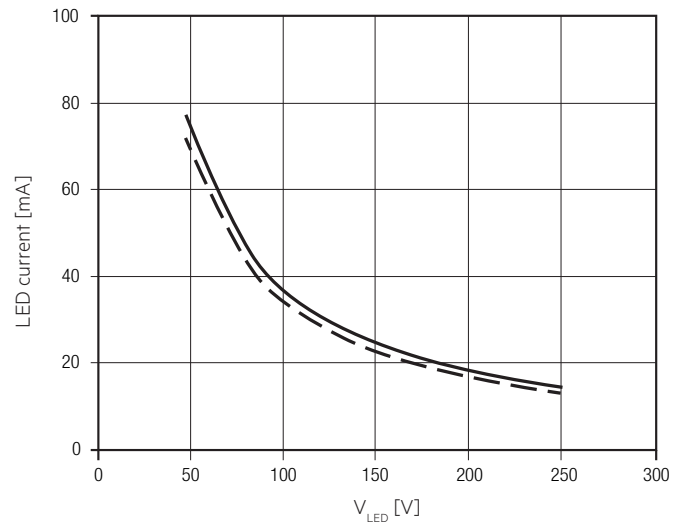
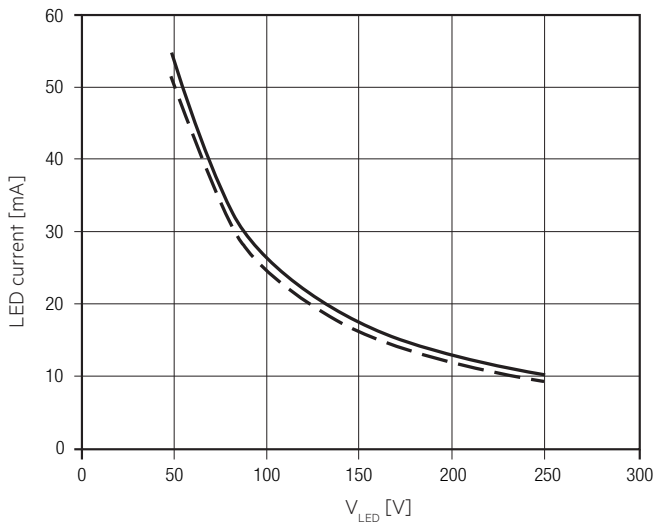

EM converterLED ST 203 NiCd/NiMH 250V  
 Article number: 89800656  
 3.6 V battery voltage  
 800 – 860 mA battery discharge current (tolerance)

EM converterLED ST 204 NiCd/NiMH 250V  
 Article number: 89800657  
 4.8 V battery voltage  
 810 – 870 mA battery discharge current (tolerance)

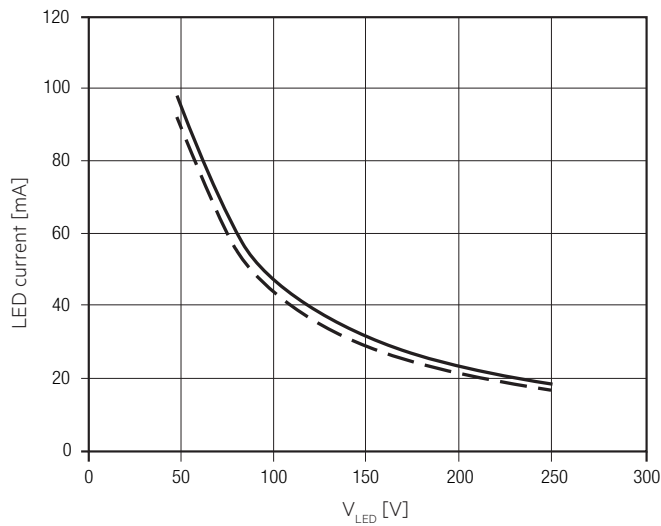

EM converterLED ST 205 NiCd/NiMH 250V  
 Article number: 89800658  
 6.0 V battery voltage  
 820 – 880 mA battery discharge current (tolerance)



 LED current at nominal battery voltage and min. battery discharge current  
 LED current at nominal battery voltage and max. battery discharge current



## 5.4 LED driver compatibility

The EM converterLED emergency unit use 3 pole technology and is compatible with most LED drivers on the market, however it is important to check that the rating of the LED driver does not exceed the values specified below:

- The max. allowed output current rating of the associated LED driver is 2 A eff (current rating of the terminals of EM converterLED) and 2.4 A peak (current rating of switching relays of EM converterLED)
- The max. allowed inrush current rating of the associated LED driver is 60 A peak for 1 ms or 84 A for 255  $\mu$ s (inrush current rating of switching relay of EM converterLED)
- The max. allowed output voltage (U-OUT) of the associated LED driver applied to the EM converterLED output is 450 V (voltage withstand between adjacent contact of the single switching relay of the EM converterLED)
- The max. allowed LED load of the associated LED driver is 150 W in operation. The load must be an LED module.

## 6. Functions

### 6.1 Duration link selection

Duration	Link position
3 hr	 Position A
2 hr	 No duration link
1 hr	 Position B

Emergency lighting LED driver supplied with duration link in 3 hours position (position A).

The position of the link will only be read on first power up. If it is changed afterwards both the battery and mains supply must be disconnected for 10 seconds to enable the EM converterLED to read the new link position on reconnection of the battery and mains. It will lead to a false battery failure indication if the link is changed after installation without this reset.

### 6.2 Status indication

System status is indicated by a bi-colour LED.

LED indication	Status	Comment
Permanent green	System OK	AC mode
Fast flashing green (0,1 sec on – 0,1 sec off)	Function test underway	
Slow flashing green (1 sec on – 1 sec off)	Duration test underway	
Red LED on	Load failure	Open circuit / Short circuit / LED failure
Slow flashing red (1 sec on – 1 sec off)	Battery failure	Battery failed the duration test or function test / Battery is defect or deep discharged / Incorrect battery voltage
Fast flashing red (0,1 sec on – 0,1 sec off)	Charging failure	Incorrect charging current
Double pulsing green	Inhibit mode	Switching into inhibit mode via controller
Green and red off	DC mode	Battery operation (emergency mode)

### 6.3 Commissioning

After installation of the luminaire and initial connection of the mains supply and battery supply to the EM converterLED ST the unit will commence charging the batteries for the initial charge time. The recharge occurs also if a new battery is connected or the module exits the rest mode condition. The following automatic commissioning duration test is only performed when a battery is replaced and fully charged.

### 6.4 Testing

#### Commissioning test

A full commissioning test is carried out automatically after permanent connection of the supply for 5 days. The easy commissioning feature will set the initial test day and time to ensure random testing of units.

#### Functional test

Functional tests are carried out for 5 seconds on a weekly basis under the control of the Micro controller. Initiation and timing of these tests is set during the commissioning of the luminaire.

#### Duration test

A full duration test is carried out yearly to check the capacity of the batteries.

For a full description of commissioning and test features please refer to application notes.

#### Test switch

An optional test switch can be wired to each EM converterLED ST. This can be used to to:

- Initiate a 5 seconds function test: press 200 ms < T < 1 s
- Execute function test as long as switch pressed: press > 1 s
- Reset selftest timer (adjust local timing): press > 10 s

**Timer reset functionality**

The timer for function and duration test can be set to a particular time of the day by either pressing the test switch for longer than 10 seconds or cycling the unswitched line supply 5 times within 1 minute. The timer adjustment will enable the test start time to be defined manually at time in day when the timer was reset. It will also disable the adaptive test algorithm thereby forcing the unit to perform the test at the same time rather than it being defined by the adaptive algorithm. This function will only work provided the interval time is greater than zero (automatic test mode enabled). The delay timer value set when the unit was commissioned will be reloaded in order to randomise the tests between adjacent units.

The factory programmed delay offset (1 – 28 days) will be loaded after the reset into the delay timer for the function and duration test in order to randomize the tests between adjacent units.

**Rest Mode / Inhibit Mode**

Emergency operation is automatically started when the mains supply is switched off. If the Rest Mode is activated, the discharging of the battery will be minimized by switching off the LED output. If the Inhibit Mode has been activated before the mains supply is switched off, Rest Mode will be automatically activated if the mains supply is switched off within 15 minutes.

Rest Mode and Inhibit Mode can be initiated by applying a short pulse between 9.5 and 22.5 V<sub>DC</sub> in amplitude for a period of 150 to 1,000 ms. This pulse shall be applied to terminals marked Rest.

After a mains reset the EM converterLED ST exits the Rest Mode. Rest Mode and Inhibit Mode can both be disabled by applying a voltage pulse of 1,000 to 2,000 ms to the terminals marked as Rest to send the RE-LIGHT/ RESET INHIBIT command.

Pulse/Mode	Standby	Emergency	Rest
150 – 1,000 ms	Inhibit	Rest	–
1,000 – 2,000 ms	Cancel inhibit	–	Re-light

## 7. Battery data

### 7.1 Battery selection

EM converterLED, 1 / 2 / 3 h

		Type	EM converterLED ST 203 NiCd/NiMH 250V		EM converterLED ST 204 NiCd/NiMH 250V		EM converterLED ST 205 NiCd/NiMH 250V	
		Article no.	89800656		89800657		89800658	
		Cells	3 cells		4 cells		5 cells	
		Duration	1 h	2 / 3 h	1 h	2 / 3 h	1 h	2 / 3 h
Technology and capacity	Design	Number of cells	Type	Article no.	Assignable batteries			
NiCd 4 Ah D cells	stick	1 x 3	Accu-NiCd 3A 55	28002773		•		
	stick	1 x 4	Accu-NiCd 4A 55	89800089			•	
	stick	1 x 5	Accu-NiCd 5A 55	28002774				•
	side by side	3 x 1	Accu-NiCd 3B 55	89800384		•		
	side by side	4 x 1	Accu-NiCd 4B 55	89800385			•	
	stick + stick	2 + 2	Accu-NiCd 4C 55	28002775			•	
	stick + stick	3 + 2	Accu-NiCd 5C 55	89800090				•
	remote box	1 x 3	Pack-NiCd 3D CON	89800389		•		
	remote box	1 x 4	Pack-NiCd 4D CON	89800390			•	
	remote box	1 x 5	Pack-NiCd 5D CON	28001181				•
NiMH 2.2 Ah Cs cells	stick	1 x 3	Accu-NiMH 3A	28002088	•			
	stick	1 x 4	Accu-NiMH 4A	28002089		•		
	stick	1 x 5	Accu-NiMH 5A	28002090			•	
	side by side	5 x 1	Accu-NiMH 5B	28002093			•	
NiMH 4 Ah LA cells	stick	1 x 3	Accu-NiMH 4Ah 3A CON	89800441		•		
	stick	1 x 4	Accu-NiMH 4Ah 4A CON	89800442			•	
	stick + stick	2 + 2	Accu-NiMH 4Ah 4C CON	89800438			•	
	stick + stick	2 + 3	Accu-NiMH 4Ah 5C CON	89800439				•

### 7.2 Battery charge / discharge data

EM converterLED, 1 / 2 / 3 h, NiMH

		Type	EM converterLED ST 203 NiCd/NiMH 250V		EM converterLED ST 204 NiCd/NiMH 250V		EM converterLED ST 205 NiCd/NiMH 250V		
		Article no.	89800656		89800657		89800658		
		Duration	1 h	2 / 3 h	1 h	2 / 3 h	1 h	2 / 3 h	
Battery charge time	Initial charge	20 h							
	Fast recharge	10 h	15 h	10 h	15 h	10 h	15 h		
	Trickle charge	continuously							
Charging current	Initial charge	110 – 150 mA	280 – 320 mA	110 – 150 mA	280 – 320 mA	110 – 150 mA	280 – 320 mA		
	Fast recharge	190 – 230 mA	310 – 350 mA	190 – 230 mA	310 – 350 mA	190 – 230 mA	310 – 350 mA		
	Trickle charge	50 – 90 mA	110 – 150 mA	50 – 90 mA	110 – 150 mA	50 – 90 mA	110 – 150 mA		
Discharge current		800 – 860 mA	800 – 860 mA	810 – 870 mA	810 – 870 mA	820 – 880 mA	820 – 880 mA		
Charge voltage range <sup>®</sup>		0.9 – 1.65 V per cell							
Discharge voltage range		1.65 – 1.05 V per cell							

<sup>®</sup> The battery will be charged below 0.9 V. The EM converterLED will indicate a battery fault.

The emergency lighting LED driver will recharge the battery normally after running the test of 61347-2-7 CL 22.3 (abnormal operating conditions).

**7.3 Accu-NiCd****4.2 / 4.5 Ah**

International designation	KRMU 33/62
Battery voltage/cell	1.2 V
Cell type	D
Case temperature range to ensure 4 years design life	+5 °C to +55 °C
Max. short term battery case temperature (shorter than 1 month over the battery lifetime)	70 °C
Max. number discharge cycles	12 cycles per year plus 4 cycles during commissioning
Max. storage time	12 months

**7.4 Accu-NiMH****2.2 Ah**

International designation	HRMU 23/43
Battery voltage/cell	1.2 V
Cell type	Cs
Case temperature range to ensure 4 years design life	+5 °C to +50 °C
Max. short term battery case temperature (shorter than 1 month over the battery lifetime)	70 °C
Max. number discharge cycles	4 cycles per year plus 30 cycles during commissioning
Max. storage time	12 months

**4.0 Ah**

International designation	HRMU 19/90
Battery voltage/cell	1.2 V
Cell type	LA
Case temperature range to ensure 4 years design life	+5 °C to +45 °C
Max. short term battery case temperature (shorter than 1 month over the battery lifetime)	70 °C
Max. number discharge cycles	4 cycles per year plus 30 cycles during commissioning
Max. storage time	12 months

**7.5 Accupack-NiCd****4.5 Ah**

Battery voltage/cell	1.2 V
Cell type	D
Ambient temperature range to ensure 4 years design life tc point	+5 °C to +40 °C +45 °C
Max. short term battery case temperature (shorter than 1 month over the battery lifetime)	70 °C
Max. number discharge cycles	4 cycles per year plus 4 cycles during commissioning
Max. storage time	6 months

**7.6 Accupack-NiMH****2.2 Ah**

Battery voltage/cell	1.2 V
Cell type	Cs
Ambient temperature range to ensure 4 years design life tc point	+5 °C to +35 °C +40 °C
Max. short term battery case temperature (shorter than 1 month over the battery lifetime)	70 °C
Max. number discharge cycles	4 cycles per year plus 4 cycles during commissioning
Max. storage time	12 months

**4.0 Ah**

Battery voltage/cell	1.2 V
Cell type	LAL
Ambient temperature range to ensure 4 years design life tc point	+5 °C to +35 °C +40 °C
Max. short term battery case temperature (shorter than 1 month over the battery lifetime)	70 °C
Max. number discharge cycles	4 cycles per year plus 4 cycles during commissioning
Max. storage time	12 months

For a higher battery temperature rating for NiMH 4 Ah refer to the EM converterLED xx MH/LiFePO4 product range.

**7.7 Wiring batteries**

To inhibit inverter operation disconnect the batteries by removing the connection at battery side.

For further informations refer to corresponding battery datasheet.

**7.8 Storage, installation and commissioning**

Relevant information about storage conditions, installation and commissioning are provided in the battery datasheets.

**8. Miscellaneous****8.1 Maximum number of switching cycles**

EM converterLEDs are tested with 50,000 mains switching cycles of the associated LED driver.

**8.2 Battery replacement**

After a battery replacement and a subsequent full charge cycle (24 h) a duration test is mandatory to prove that with the new battery the rated duration is achieved.

**8.3 Mains-connected transformers**

The EM converterLED does not contain mains-connected windings of transformers.

**8.4 Additional information**

Additional technical information at [www.tridonic.com](http://www.tridonic.com) → Technical Data

Lifetime declarations are informative and represent no warranty claim. No warranty if device was opened.