

EM converterLED SELFTEST 232 LiFePO₄ 250V 3h Kit

SELFTEST version

**Product description**

- _ Kit with emergency lighting LED driver, battery for 3 h duration and indication LED
- _ Self-contained emergency lighting LED driver with self-test function
- _ For LED modules with a forward voltage of 48 – 250 V
- _ Low profile casing (21 x 30 mm)
- _ For luminaire installation
- _ EM = Emergency
- _ Nominal lifetime up to 100,000 h
- _ 5 years guarantee (Conditions at <https://www.tridonic.com/en/int/services/manufacturer-guarantee-conditions>)

Properties

- _ Non maintained operation
- _ Self-test as per IEC 62034
- _ 3 h rated duration
- _ Operating time selectable with plug (duration link)
- _ Compatible with most constant current LED drivers (see data sheet, LED driver compatibility)
- _ 3-pole technology: 2-pole LED module changeover and delayed power switching for the LED driver
- _ Automatic shutdown of output if LED load is out of range
- _ Constant power output
- _ Two-colour status display LED
- _ Electronic charge system
- _ Deep discharge protection
- _ Short-circuit-proof battery connection
- _ Polarity reversal protection for battery provided by 3-pole connector
- Self-test:
 - _ Status of the battery
 - _ Status of the LED
 - _ Function test
 - _ Duration test

Batteries

- _ High-temperature cells
- _ 18650 cells
- _ 4 – 8 years design life for LiFePO₄ batteries
- _ 5 years guarantee for LiFePO₄ batteries (conditions at <https://www.tridonic.com/en/int/services/manufacturer-guarantee-conditions>)
- _ LiFePO₄ batteries with Tridonic LiFeGuard

Website

<http://www.tridonic.com/89801266>



EM converterLED SELFTEST 232 LiFePO₄ 250V 3h Kit

SELFTEST version

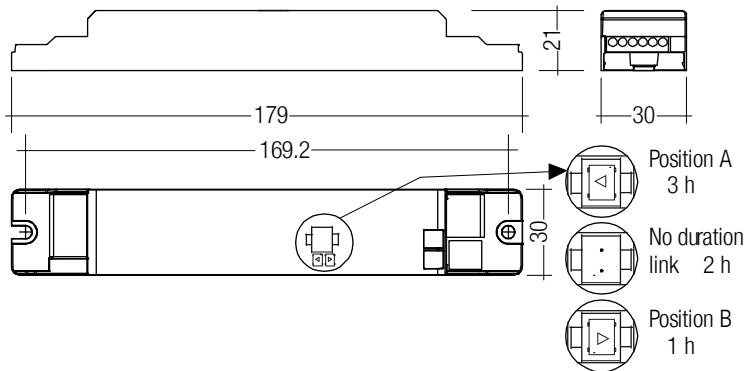
**Ordering data**

Type	Article number	Rated duration	Packaging, carton	Packaging, pallet	Weight per pc.	Dimensions L x W x H
EMcLED ST 332A LiFePO ₄ 250V KIT	89801266	3 h	10 pc(s).	640 pc(s).	0.241 kg	179 x 30 x 21 mm
EMcLED ST 333 LiFePO ₄ 250V KIT	89801267	3 h	10 pc(s).	640 pc(s).	0.313 kg	179 x 30 x 21 mm
EMcLED ST 334 LiFePO ₄ 250V KIT	89801268	3 h	10 pc(s).	400 pc(s).	0.353 kg	179 x 30 x 21 mm

Technical data

Rated supply voltage	220 – 240 V
AC voltage range	198 – 264 V
Mains frequency	50 / 60 Hz
Forward voltage range LED module	50 – 250 V
Output current	Refer to data sheet
Starting time	< 0.5 s from detection of emergency event
Overvoltage protection	320 V (for 48 h)
U-OUT (including open- / short-circuit and double load)	300 V
Max. open circuit voltage	300 V
Ambient temperature t_a	-25 ... +55 °C
Max. casing temperature t_c	80 °C
Mains voltage changeover threshold	According to EN 60598-2-22
Mains surge capability (between L - N)	1 kV
Mains surge capability (between L/N - PE)	2 kV
Type of protection	IP20
Rest mode max. number of emergency units	100
Rest mode max. wiring distance	1,000 m
Functional test	Weekly 5s test
Duration test	Yearly 1 h / 2 h / 3 h test
Lifetime	up to 100,000 h
Guarantee (conditions at www.tridonic.com)	5 Year(s)
Dimensions L x W x H	179 x 30 x 21 mm

Approval marks**Standards**

EN 61347-1, EN 61347-2-13, EN 61347-2-7, EN 55015, EN 61000-3-2, EN 61000-3-3, EN 61547, EN 60068-2-64, EN 60068-2-29, EN 60068-2-30, EN 62384, according to EN 50172, according to EN 60598-2-22, acc. to EN 62034

Specific technical data

Type	Battery technology ^①	Rated duration	λ over full operating range (min.)	λ over full operating range (max.)	Typ. output power P emergency	Mains current in charging operation			Mains power in charging operation		
						Initial charge	Fast recharge	Trickle charge	Initial charge	Fast recharge	Trickle charge
EMcLED ST 332A LiFePO4 250V KIT	LiFePO4	3 h	0.48C	0.55C	2.3 W	22 mA	22 mA	22 / 12 mA	3 W	3 W	3 / 1.4 W
EMcLED ST 333 LiFePO4 250V KIT	LiFePO4	3 h	0.48C	0.60C	3.2 W	28 mA	28 mA	28 / 12 mA	4 W	4 W	4 / 1.4 W
EMcLED ST 334 LiFePO4 250V KIT	LiFePO4	3 h	0.48C	0.60C	3.7 W	28 mA	28 mA	28 / 12 mA	4 W	4 W	4 / 1.4 W

① 12 h battery charging time for 2 h emergency lighting function when used with LiFePO4 batteries.

1. Standards

- EN 61347-1
- EN 61347-2-13
- EN 61347-2-7
- EN 55015
- EN 61000-3-2
- EN 61000-3-3
- EN 61547
- EN 60068-2-64
- EN 60068-2-29
- EN 60068-2-30
- EN 62384
- according to EN 50172
- according to EN 60598-2-22
- according to EN 62034

Meaning of marking 

Double or reinforced insulation for built-in electronic LED drivers. The control gear relies upon the luminaire enclosure for protection against accidental contact with live parts.

1.1 Glow-wire test

according to EN 61347-1 with increased temperature of 850 °C passed.

1.2 Insulation and electric strength testing of luminaires

Electronic LED-drivers can be damaged by high voltage. This has to be considered during the routine testing of the luminaires in production.

According to IEC 60598-1 Annex Q (informative only!) or ENEC 303-Annex A, each luminaire should be submitted to an insulation test with 500 V_{DC} for 1 second. This test voltage should be connected between the interconnected phase and neutral terminals and the earth terminal. The insulation resistance must be at least 2 MΩ.

As an alternative, IEC 60598-1 Annex Q describes a test of the electrical strength with 1,500 V_{AC} (or 1,414 x 1,500 V_{DC}). To avoid damage to the electronic devices this test **must not be conducted**.

2. Thermal details and lifetime

2.1 Lifetime

Average lifetime 50,000 hours under rated conditions with a failure rate of less than 10 %. Average failure rate of 0.2 % per 1000 operating hours.

Expected lifetime

EMcLED ST 232A	tc	60 °C	65 °C	70 °C	75 °C	80 °C
LiFePO4 250V KIT	lifetime	> 100,000 h	> 100,000 h	> 100,000 h	97,000 h	68,000 h
EMcLED ST 233	tc	60 °C	65 °C	70 °C	75 °C	80 °C
LiFePO4 250V KIT	lifetime	> 100,000 h	> 100,000 h	> 100,000 h	87,000 h	61,000 h
EMcLED ST 234	tc	60 °C	65 °C	70 °C	75 °C	80 °C
LiFePO4 250V KIT	lifetime	> 100,000 h	> 100,000 h	> 100,000 h	86,000 h	60,000 h

The emergency lighting LED driver is designed for a lifetime stated above under reference conditions and with a failure probability of less than 10 %.

The relation of tc to ta temperature depends also on the luminaire design. If the measured tc temperature is approx. 5 K below tc max., ta temperature should be checked and eventually critical components (e.g. ELCAP) measured. Detailed information on request.

3. Installation / Wiring

3.1 Wiring diagram

One or more LED modules with a total forward voltage of 48 to 250 V can be connected to the EM converterLED module. These LED module(s), marked with "Emergency" are operated in emergency mode from the associated battery. In normal mains mode all LED modules are operated by the mains LED driver.

EM converterLED SELFTEST with one LED module for non-maintained emergency operation

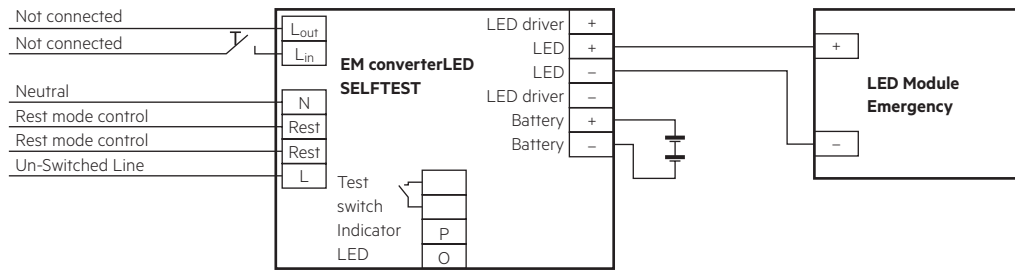

EM converterLED SELFTEST with a standard LED driver and one LED module for mains and emergency operation

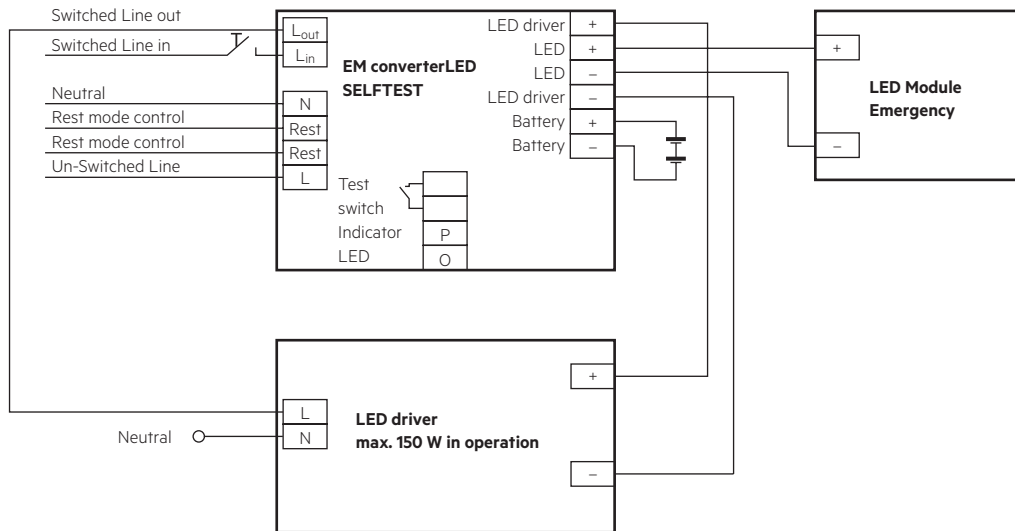

EM converterLED SELFTEST with a standard LED driver and series operation of LED modules

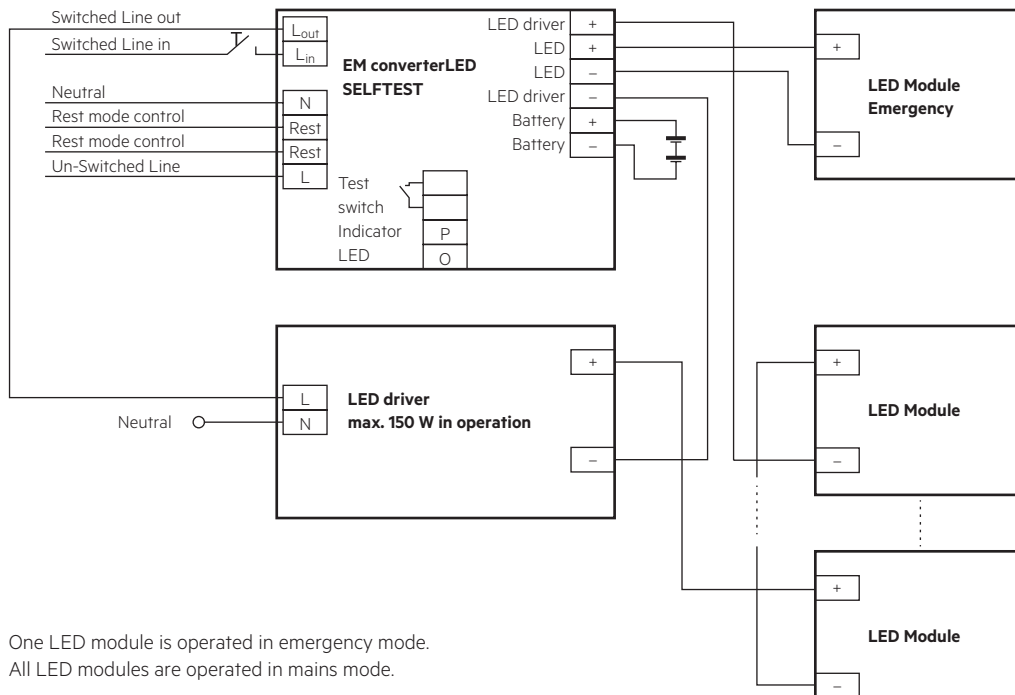

One LED module is operated in emergency mode.
All LED modules are operated in mains mode.

EM converterLED SELFTEST with a standard LED driver and parallel operation of LED modules

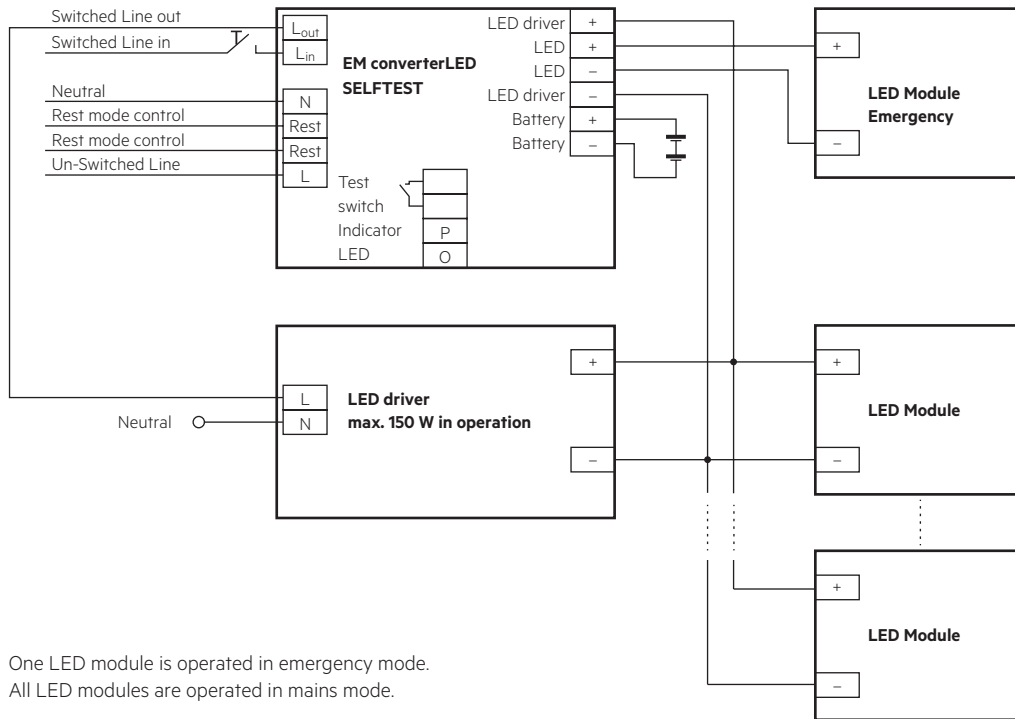

One LED module is operated in emergency mode.
All LED modules are operated in mains mode.

3.2 Wiring type and cross section

Solid wire with a cross section of 0.5 – 1.5 mm². Strip 8 – 9 mm of insulation from the cables to ensure perfect operation of terminals.

Wiring: LED module/LED driver/supply

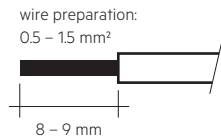

3.3 Battery connection

Direct connection

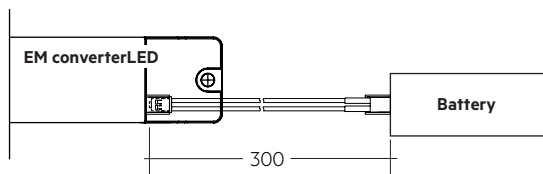

Connection with extension

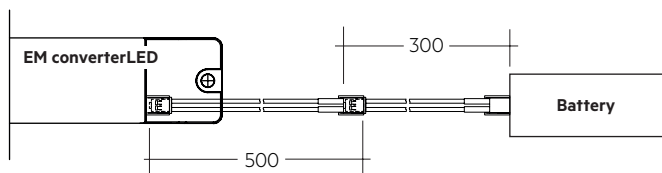

3.4 Loose wiring

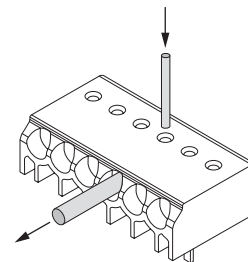

Loosen wire through twisting and pulling or using a Ø 1mm release tool

3.5 Wiring guidelines

- The output to the LED is DC but has high frequency content, which should be considered for good EMC compliance.
- Separate LED leads from the mains and REST connections and wiring for good EMC performance.
- Maximum lead length on the LED terminals is 3 m. For a good EMC performance keep the LED wiring as short as possible.
- Route the secondary wires (LED module) in parallel to ensure good EMC performance.
- Maximum lead length for the Test switch and Indicator LED connection is 1 m. Separate the test switch and Indicator LED wiring from the LED leads to prevent noise coupling.
- Battery leads are specified with 0.5 mm cross section and a length of 0.8 m
- REST terminals are mains proof.
- Protect the wiring against short circuits to earth (sharp edged metal parts, metal cable clips, louver, etc.) to avoid the damage of the control gear.

To ensure that a luminaire containing LED emergency units complies with EN 55015 for radio frequency conducted interference in both normal and emergency mode it is essential to follow good practice in the wiring layout.

Within the luminaire route the switched and unswitched 50 Hz supply wiring as short as possible and keep it as far away as possible from the LED leads. Through wiring may affect the EMC performance of the luminaire.

Do not exceed the max. length of LED leads to the LED module. Note that the length of the EM converterLED leads to the LED module is added to the length of the leads from the LED driver to the EM converterLED module when considering the max. permitted lead length of the LED driver.

3.6 Maximum lead length

LED	3 m (6 m loop)
Status indication LED	1 m
Batteries	0.8 m

3.7 Use of different phases

The use of different phases for switched line and unswitched line is allowed. When using different phases, the unswitched line must fail if the switched line fails. This is required to assure correct switching into emergency mode. It can be realised with a relay.

4. Mechanical values

4.1 Housing properties

- Casing manufactured from polycarbonate.
- Type of protection: IP20
- Max. torque at the mounting screws: 0.8 Nm

4.2 Mechanical data accessories

LED status indicator

- Bi-colour
- Mounting hole 6.5 mm diameter, 1 – 1.6 mm thickness
- Lead length 0.3 m / 1.0 m
- Insulation rating: 90 °C
- Plug connection

Test switch

- Mounting hole 7.0 mm diameter
- Lead length 0.55 m
- Plug connection

Battery connection

- Plug connection 0.3 m
- Extension 0.5 m

5. Electrical values

5.1 Maximum loading of automatic circuit breakers

Automatic circuit breaker type	B10	B13	B16	B20	C10	C13	C16	C20	Inrush current	
Installation Ø	1.5 mm ²	1.5 mm ²	1.5 mm ²	2.5 mm ²	1.5 mm ²	1.5 mm ²	1.5 mm ²	2.5 mm ²	I _{max}	time
EMcLED ST LiFePO4 250V KIT	90	130	130	130	180	260	260	260	10 A	120 µs

5.2 Insulation matrix

	Mains	Switched Live	Battery, LED, Test switch, Indicator LED	REST	Control gear
Mains	–	•	••	•	•
Switched Live	•	–	••	•	•
Battery, LED, Test switch, Indicator LED	••	••	–	•	–
REST	•	•	•	–	•
Control gear	•	•	–	•	–

• Represents basic insulation

•• Represents double or reinforced insulation

When using a non-SELV LED driver insulate the battery, LED, test switch and indicator LED in the luminaire according to the U-OUT rating of the LED driver.

5.3 Typ. LED current/voltage characteristics

The LED current in emergency mode is automatically adjusted by the EM converterLED module based on the total forward voltage of the LED modules connected and the associated battery. The start of the LED in emergency mode does not result in a current peak.

EMcLED ST 232A LiFePO4 250V KIT
 Article number: 89801266
 LiFePO₄ battery, 3.2 V battery voltage
 845 – 905 mA battery discharge current (tolerance)

EMcLED ST 233 LiFePO4 250V KIT
 Article number: 89801267
 LiFePO₄ battery, 3.2 V battery voltage
 1,150 – 1,250 mA battery discharge current (tolerance)

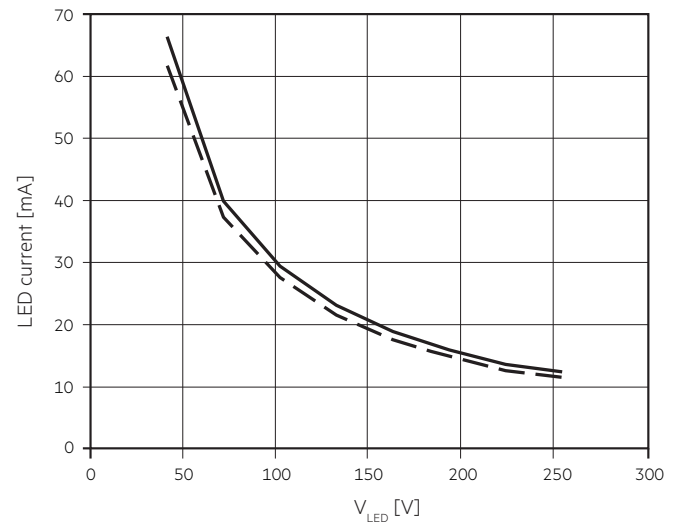
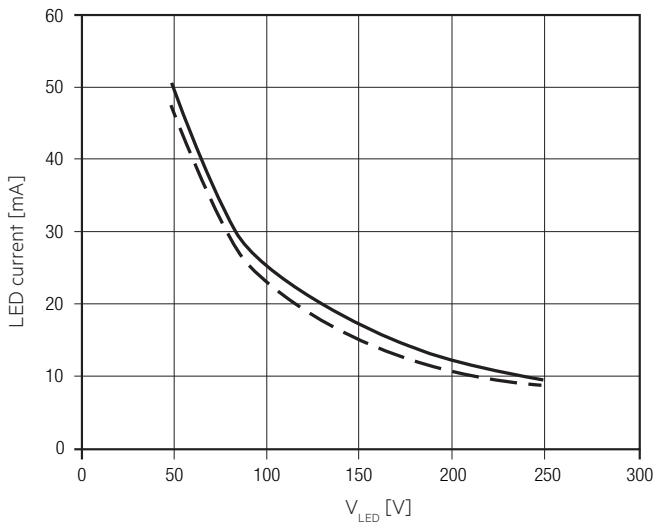

EMcLED ST 234 LiFePO4 250V KIT
 Article number: 89801268
 LiFePO₄ battery, 3.2 V battery voltage
 1,450 – 1,550 mA battery discharge current (tolerance)

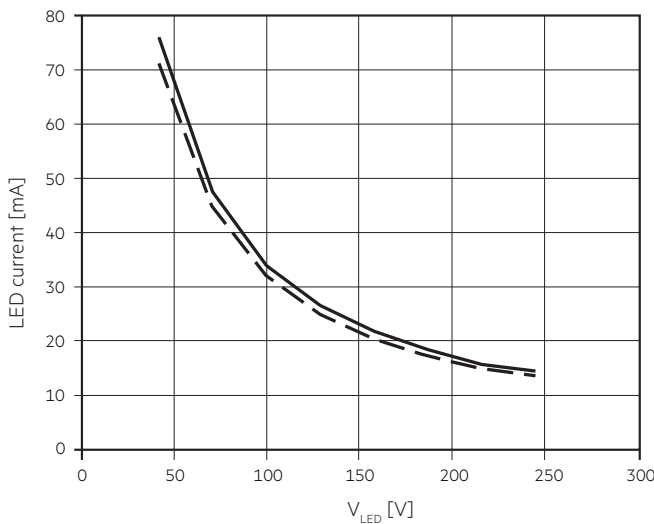

- LED current at nominal battery voltage and min. battery discharge current
- LED current at nominal battery voltage and max. battery discharge current

5.4 LED driver compatibility



The EM converterLED emergency unit use 3 pole technology and is compatible with most LED drivers on the market, however it is important to check that the rating of the LED driver does not exceed the values specified below:

- The max. allowed output current rating of the associated LED driver is 2 A eff (Current rating of the terminals of EM converterLED) and 2.4 A peak (Current rating of switching relays of EM converterLED)
- The max. allowed inrush current rating of the associated LED driver is 60 A peak for 1 ms or 84 A for 255 μs (inrush current rating of switching relay of EM converterLED)
- The max. allowed output voltage of the associated LED driver applied to the EM converterLED output is 450 V (voltage withstand between adjacent contact of the single switching relay of the EM converterLED)
- The max. allowed LED load of the associated LED driver is 150 W in operation. The load must be an LED module.

Check compatibility with the carried out function test (duration at least 5 seconds) individually for each device.

6. Functions

6.1 Duration link selection

Duration	Link position
3 hr	 Position A
2 hr	 No duration link
1 hr	 Position B

Emergency lighting LED driver supplied with duration link in 3 hours position (position A).

The position of the link will only be read on first power up. If it is changed afterwards both the battery and mains supply must be disconnected for 10 seconds to enable the EM converterLED to read the new link position on reconnection of the battery and mains. It will lead to a false battery failure indication if the link is changed after installation without this reset.

6.2 Status indication

System status is indicated by a bi-colour LED.

LED indication	Status	Comment
Permanent green	System OK	AC mode
Fast flashing green (0,1 sec on – 0,1 sec off)	Function test underway	
Slow flashing green (1 sec on – 1 sec off)	Duration test underway	
Red LED on	Load failure	Open circuit / Short circuit / LED failure
Slow flashing red (1 sec on – 1 sec off)	Battery failure	Battery failed the duration test or function test / Battery is defect or deep discharged/ Incorrect battery voltage / battery outside operating temp
Fast flashing red (0,1 sec on – 0,1 sec off)	Charging failure	Incorrect charging current
Double pulsing green	Inhibit mode	Switching into inhibit mode via controller
Green and red off	DC mode	Battery operation (emergency mode)

6.3 Commissioning

After installation of the luminaire and initial connection of the mains supply and battery supply to the EM converterLED the unit will commence charging the batteries for the initial charge time. The recharge occurs also if a new battery is connected or the module exits the rest mode condition. The following automatic commissioning duration test is only performed when a battery is replaced and fully charged.

6.4 Testing

Commissioning test

A full commissioning test is carried out automatically after permanent connection of the supply for 5 days. The easy commissioning feature will set the initial test day and time to ensure random testing of units.

Functional test

Functional tests are carried out for 5 seconds on a weekly basis under the control of the Micro controller. Initiation and timing of these tests is set during the commissioning of the luminaire.

Duration test

A full duration test is carried out yearly to check the capacity of the batteries.

For a full description of commissioning and test features please refer to product manual.

Test switch

An optional test switch can be wired to each EM converterLED. This can be used to:

- Initiate a 5 seconds function test: press 200 ms < T < 1 s
- Execute function test as long as switch pressed: press > 1 s
- Reset selftest timer (adjust local timing): press > 10 s

Timer reset functionality

The timer for function and duration test can be set to a particular time of the day by either pressing the test switch for longer than 10 seconds or cycling the unswitched line supply 5 times within 1 minute. The timer adjustment will enable the test start time to be defined manually at time in day when the timer was reset. It will also disable the adaptive test algorithm thereby forcing the unit to perform the test at the same time rather than it being defined by the adaptive algorithm. The delay timer value set when the unit was commissioned will be reloaded in order to randomise the tests between adjacent units.

The factory programmed delay offset (1 – 28 days) will be loaded after the reset into the delay timer for the function and duration test in order to randomize the tests between adjacent units.

Rest Mode / Inhibit Mode

Emergency operation is automatically started when the mains supply is switched off. If the Rest Mode is activated, the discharging of the battery will be minimized by switching off the LED output. If the Inhibit Mode has been activated before the mains supply is switched off, Rest Mode will be automatically activated if the mains supply is switched off within 15 minutes.

Rest Mode and Inhibit Mode can be initiated by applying a short pulse between 9.5 and 22.5 V_{dc} in amplitude for a period of 150 to 1,000 ms. This pulse shall be applied to terminals marked Rest.

After a mains reset the EM converterLED exits the Rest Mode. Rest Mode and Inhibit Mode can both be disabled by applying a voltage pulse of 1,000 to 2,000 ms to the terminals marked as Rest to send the RE-LIGHT/ RESET INHIBIT command.

Rest Mode / Inhibit Mode are not supported from EM converterLED in case of combination with a 1-cell battery.

After 21 days in Rest Mode, 50 % of the operating time remains (according to the IEC/EN 61347-2-7 standard) and the internal timer stops to preserve the remaining battery energy.

By re-powering the unit with mains supply the internal timer is re-set. Random testing is recommissioned by automatically reloading a 1-28 day delay time offset preinstalled in the device during manufacture.

Rest Mode / Inhibit Mode are not supported from EM converterLED in case of combination with a 1-cell LiFePO₄ battery.

Pulse/Mode	Standby	Emergency	Rest
150 – 1,000 ms	Inhibit	Rest	–
1,000 – 2,000 ms	Cancel inhibit	–	Re-light

7. Battery data

7.1 Battery selection

EMcLED ST, 3 h, LiFePO₄

		Type	EMcLED ST 232A LiFePO ₄ 250V KIT	EMcLED ST 233 LiFePO ₄ 250V KIT	EMcLED ST 234 LiFePO ₄ 250V KIT
		Article no.	89801266	89801267	89801268
		Duration	3 h	3 h	3 h
Technology and capacity	Design	Number of cells	Type	Article no.	Assignable batteries
LiFePO ₄ 1.5 Ah 18650 cells	stick	1 x 3	Accu-LiFePO ₄ 3A CON	28002320	•
	stick	1 x 4	Accu-LiFePO ₄ 4A CON	28002322	•
	stick	1 x 5	Accu-LiFePO ₄ 5A CON	28002325	•

Note: Only use Tridonic 18650 LiFePO₄ batteries of the correct cell configuration.

7.2 Battery charge / discharge data

EMcLED ST, 3 h, LiFePO₄

Type	EMcLED ST 232A LiFePO ₄ 250V KIT	EMcLED ST 233 LiFePO ₄ 250V KIT	EMcLED ST 234 LiFePO ₄ 250V KIT
Article no.	89801266	89801267	89801268
Duration	3 h	3 h	3 h
Battery charge time	Initial charge	24 h	
	Fast recharge	24 h	
	Trickle charge	continuously and battery voltage controlled	
Charging current	Initial charge	250 – 290 mA	430 – 470 mA
	Fast recharge	250 – 290 mA	430 – 470 mA
	Trickle charge ^①	250 – 290 mA / 0 mA	430 – 470 mA / 0 mA
Discharge current	845 – 905 mA	1,150 – 1,250 mA	1,450 – 1,550 mA
Charge voltage range ^②	2.0 – 3.65 V		
Discharge voltage range	3.65 – 2.60 V		

^① Automatic recharge when battery voltage falls below 3.4 V. Charger off (0 mA) when battery voltage exceeds 3.6 V.

Note: Battery protected against operation at excessive temperatures (charging stopped when battery cell temperature < 0 °C or > 60 °C).

The emergency lighting LED driver will recharge the battery normally after running the test of 61347-2-7 CL 22.3 (abnormal operating conditions).

^② The battery will not be charged below 2.0 V.

7.3 Accu-LiFePO₄

Capacity 1.5 Ah

International designation	IFpR 19/66
Battery voltage/cell	3.2 V
Cell type	18650
Case temperature range to ensure	
4 years design life	+55 °C
6 years design life	+45 °C
8 years design life	+35 °C
Max. short term temperature (reduced lifetime)	70 °C
Max. number discharge cycles	50 cycles total
Max. storage time	15 months
	at -20 °C to +35 °C

Comply with UN 38.3 and IEC 62133 (safety testing) protected against over charge, over discharge, charging at excessive temperatures, short-circuit and over current.

7.4 Safety



Note: LiFeGuard ensures safe and reliable battery operation by offering a comprehensive three-layered safety system. It addresses the cell, battery pack and emergency driver.

7.4.1 Deep discharge protection

When the battery remains connected without charging for a long period of time after the battery cut off of the driver the battery voltage can still drop. To make sure the cells are not damaged by this voltage drop, the battery protection prevents the battery from further discharge below 2.0 V.

7.4.2 Overcharge protection

If in case of an error or the use of a wrong driver the battery gets overcharged the battery protection will disconnect the battery from the driver at a voltage of 3.9 V. A discharge of the battery is still possible after the protection circuit was triggered to guarantee emergency operation.

7.4.3 Short-circuit protection

In case of a short circuit the battery protection opens the connection to the driver and the output is therefore free of voltage. The output will be reactivated again when the short circuit is removed.

7.4.4 Overtemperature protection

The battery is protected against temporary thermal overheating. If the temperature limit is exceeded the further charging of the battery is no longer possible. The temperature protection is activated below approx. 0 °C and above approx. +60 °C. The discharging of the battery is still possible to guarantee emergency operation. The charging is automatically activated when the temperature is within the range of 0 to 60°C again.



Battery has built in thermal sensor for safe charging. Mount battery away from heat source.

Positioning of the thermal sensor see battery data sheet.

7.5 Storage, installation and commissioning

Relevant information about storage conditions, installation and commissioning are provided in the battery datasheets.

8. Miscellaneous

8.1 Maximum number of switching cycles

EM converterLEDs are tested with 50,000 mains switching cycles of the associated LED driver.

8.2 Battery replacement

After a battery replacement and a subsequent full charge cycle (24 h) a duration test is mandatory to prove that with the new battery the rated duration is achieved.

8.3 Mains-connected transformers

The EM converterLED does not contain mains-connected windings of transformers.

8.4 Additional information

Additional technical information at www.tridonic.com → Technical Data

Lifetime declarations are informative and represent no warranty claim. No warranty if device was opened.