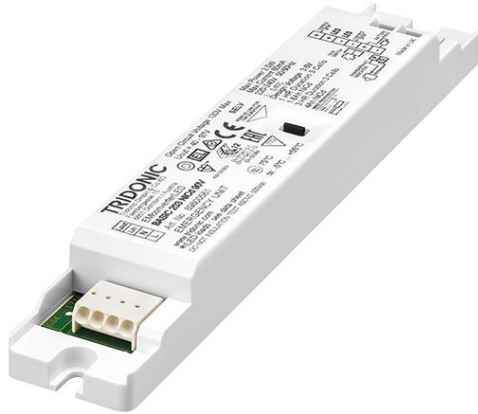

EM converterLED BASIC NiCd/NiMH 90 V

Ausführung BASIC

**Product description**

- _ Emergency lighting LED driver for manual testing
- _ For self-contained emergency lighting
- _ For LED modules with a forward voltage of 40 – 97 V
- _ SELV for output voltage < 120 V DC
- _ Low profile casing (21 x 30 mm cross-section)
- _ For luminaire installation
- _ EM = Emergency
- _ Nominal lifetime up to 100,000 h
- _ 5 years guarantee (conditions at <https://www.tridonic.com/en/int/services/manufacturer-guarantee-conditions>)

Properties

- _ Non maintained operation
- _ 1 or 3 h rated duration
- _ Operating time selectable with plug (duration link)
- _ Compatible with all dimmable and non-dimmable constant current LED driver (see data sheet, LED driver compatibility)
- _ 3-pole technology: 2-pole LED module changeover and delayed power switching for the LED driver
- _ Automatic shutdown of output if LED load is out of range
- _ Constant power output
- _ Maximum light output for all LED modules
- _ Electronic charge system
- _ Deep discharge protection
- _ Short-circuit-proof battery connection
- _ Polarity reversal protection for battery

Batteries

- _ High-temperature cells
- _ NiCd or NiMH batteries
- _ D, Cs or LA cells
- _ 4 year design life
- _ 2 years guarantee (conditions at <https://www.tridonic.com/en/int/services/manufacturer-guarantee-conditions>)
- _ For battery compatibility refer to data sheet

Website

<http://www.tridonic.com/89800561>



EM converterLED BASIC NiCd/NiMH 90 V

Ausführung BASIC

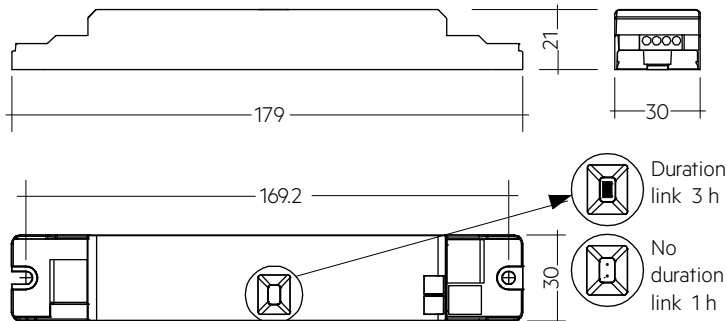

Note: Supply of control gear with duration link in 3 hours position. Remove duration link for duration of 1 h. Duration link must be set before battery and mains connection.

Ordering data

Type	Article number	Rated duration	Number of cells	Packaging, carton	Packaging, pallet	Weight per pc.	Dimensions L x W x H
EM converterLED BASIC 203 NiCd/NiMH 90V	89800561	1/3 h	3	10 pc(s).	1,600 pc(s).	0.065 kg	179 x 30 x 21 mm
EM converterLED BASIC 204 NiCd/NiMH 90V	89800562	1/3 h	4	10 pc(s).	1,600 pc(s).	0.065 kg	179 x 30 x 21 mm

Technical data

Rated supply voltage	220 – 240 V
AC voltage range	198 – 264 V
Mains frequency	50 / 60 Hz
Typ. λ (at 230 V, 50 Hz)	0.6C
Forward voltage range LED module	40 – 97 V
Output current	Refer to data sheet
Starting time	< 0.25 s from detection of emergency event
Overvoltage protection	320 V (for 48 h)
U-OUT (including open- / short-circuit and double load)	120 V
Max. open circuit voltage	120 V
Battery charging time ^{①②}	24 h
Ambient temperature <i>t</i> _a	-5 ... +55 °C
Max. casing temperature <i>t</i> _c	75 °C
Mains voltage changeover threshold	According to EN 60598-2-22
Mains surge capability (between L - N)	1 kV
Mains surge capability (between L/N - PE)	2 kV
Type of protection	IP20
Lifetime	up to 100,000 h
Guarantee (conditions at www.tridonic.com)	5 Year(s)
Dimensions L x W x H	179 x 30 x 21 mm

Approval marks



Standards

according to EN 50172, according to EN 60598-2-22, EN 61347-1, EN 61347-2-13, EN 61347-2-7, EN 55015, EN 61000-3-2, EN 61000-3-3, EN 61547, EN 60068-2-64, EN 60068-2-29, EN 60068-2-30, EN 62384

Specific technical data

Type	Battery technology	Rated duration	Typ. output power P emergency	Mains current in charging operation			Mains power in charging operation		
				Initial charge	Fast recharge	Trickle charge	Initial charge	Fast recharge	Trickle charge
EM converterLED BASIC 203 NiCd/NiMH 90V	NiCd	1 h	2.5 W	17 mA	17 mA	15 mA	2.4 W	2.4 W	1.8 W
EM converterLED BASIC 203 NiCd/NiMH 90V	NiCd	3 h	2.5 W	23 mA	23 mA	18 mA	3.5 W	3.5 W	2.4 W
EM converterLED BASIC 204 NiCd/NiMH 90V	NiCd	1 h	3.5 W	18 mA	18 mA	17 mA	2.5 W	2.5 W	2.0 W
EM converterLED BASIC 204 NiCd/NiMH 90V	NiCd	3 h	3.5 W	24 mA	24 mA	20 mA	3.8 W	3.8 W	2.5 W

① 16 h battery charging time for 2 h emergency lighting function according to AS 2293.

② 12 h battery charging time for 2 h emergency lighting function when used with NiCd and NiMH batteries.

EMcLED Strain-relief set 240x43x30mm

Accessory

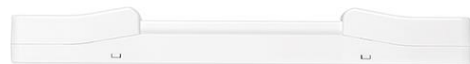

Product description

- _ Optional strain-relief for independent applications
- _ Transforms the LED driver into a fully class II compatible LED driver (e.g. ceiling installation)
- _ Easy and tool-free mounting to the LED driver, screwless cable-clamp channels with strain-relief (240 x 43 x 30 mm)

Website

<http://www.tridonic.com/28003813>



Emergency lighting units

EM converterLED

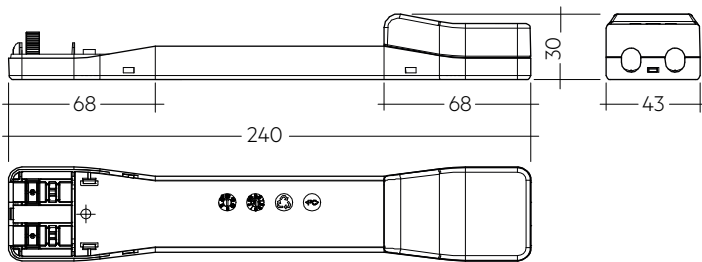

Permissible cable jacket diameter 2.2 – 9 mm

Ordering data

Type	Article number	Packaging, carton	Weight per pc.
EM cLED SR	28003813	10 pc(s).	0.08 kg

Approval marks



Test switch EM3

Accessory



Product description

- _ For connection to the emergency lighting unit
- _ For checking the device function
- _ Plug connection
- _ Dielectric strength: 1,500 V AC for 60 seconds
- _ Lead length 0.55m
- _ Mounting hole 7,0 mm diameter

Website

<http://www.tridonic.com/89899956>



Ordering data

Type	Article number	Packaging, bag	Packaging, carton	Weight per pc.
Test switch EM 3	89899956	25 pc(s).	2,000 pc(s).	0.01 kg

Approval marks



Status indication green LED EM CON

Accessory

**Product description**

- _ A green LED indicates that charging current is flowing into the battery
- _ 0.3 / 1.0 m cable length
- _ Plug connection

Website

<http://www.tridonic.com/89800269>

**Ordering data**

Type	Article number	Packaging, bag	Packaging, carton	Weight per pc.
LED EM green, 1.0 m CON	89800269	25 pc(s).	800 pc(s).	0.018 kg
LED EM green, HO 1.0 m CON	89800271	25 pc(s).	200 pc(s).	0.016 kg
LED EM green, 0.6 m CON	89800472	25 pc(s).	200 pc(s).	0.010 kg
LED EM green, HO 0.6 m CON	89800473	25 pc(s).	200 pc(s).	0.010 kg
LED EM green, 0.3 m CON	89800270	25 pc(s).	200 pc(s).	0.007 kg
LED EM green, HO 0.3 m CON	89800272	25 pc(s).	200 pc(s).	0.007 kg

1. Standards

- EN 61347-1
- EN 61347-2-13
- EN 61347-2-7
- EN 55015
- EN 61000-3-2
- EN 61000-3-3
- EN 61547
- EN 60068-2-64
- EN 60068-2-29
- EN 60068-2-30
- EN 62384
- according to EN 50172
- according to EN 60598-2-22

Meaning of marking 

Double or reinforced insulation for built-in electronic LED drivers. The control gear relies upon the luminaire enclosure for protection against accidental contact with live parts.

1.1 Glow-wire test

according to EN 61347-1 with increased temperature of 850 °C passed.

1.2 Insulation and electric strength testing of luminaires

Electronic LED-drivers can be damaged by high voltage. This has to be considered during the routine testing of the luminaires in production.

According to IEC 60598-1 Annex Q (informative only!) or ENEC 303-Annex A, each luminaire should be submitted to an insulation test with 500 V_{dc} for 1 second. This test voltage should be connected between the interconnected phase and neutral terminals and the earth terminal. The insulation resistance must be at least 2 MΩ.

As an alternative, IEC 60598-1 Annex Q describes a test of the electrical strength with 1,500 V_{AC} (or 1,414 x 1,500 V_{DC}). To avoid damage to the electronic devices this test **must not be conducted**.

2. Thermal details and lifetime

2.1 Lifetime

Average lifetime 50,000 hours under rated conditions with a failure rate of less than 10 %. Average failure rate of 0.2 % per 1000 operating hours.

Expected lifetime

EM converterLED BASIC 203 NiCd/NiMH 90V	t _c	65 °C	70 °C	75 °C
	lifetime	> 100,000 h	93,000 h	66,000 h
EM converterLED BASIC 204 NiCd/NiMH 90V	t _c	65 °C	70 °C	75 °C
	lifetime	> 100,000 h	79,000 h	55,000 h

The emergency lighting LED driver is designed for a lifetime stated above under reference conditions and with a failure probability of less than 10 %.

The relation of t_c to t_a temperature depends also on the luminaire design. If the measured t_c temperature is approx. 5 K below t_c max., t_a temperature should be checked and eventually critical components (e.g. ELCAP) measured. Detailed information on request.

3. Installation / Wiring

3.1 Wiring diagram

One or more LED modules with a total forward voltage of 40 to 97 V can be connected to the EM converterLED 90V module. These LED module(s), marked with "Emergency" are operated in emergency mode from the associated battery. In normal mains mode all LED modules are operated by the LED driver from the mains supply.

Use of the test switch:

For checking the device function press the test switch for a minimum of 3 seconds.

EM converterLED BASIC with one LED module for non-maintained emergency operation

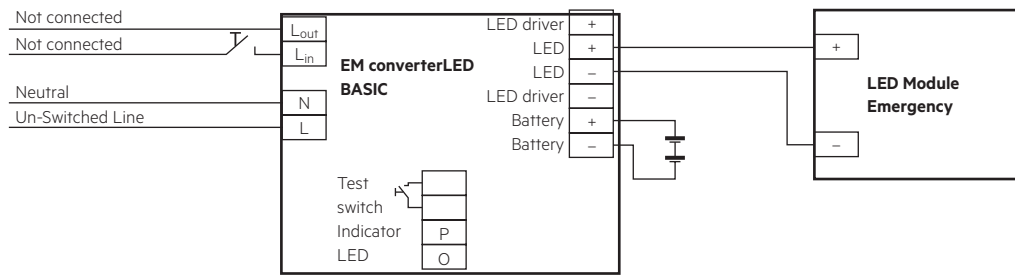

EM converterLED BASIC with a standard LED driver and one LED module for mains and emergency operation

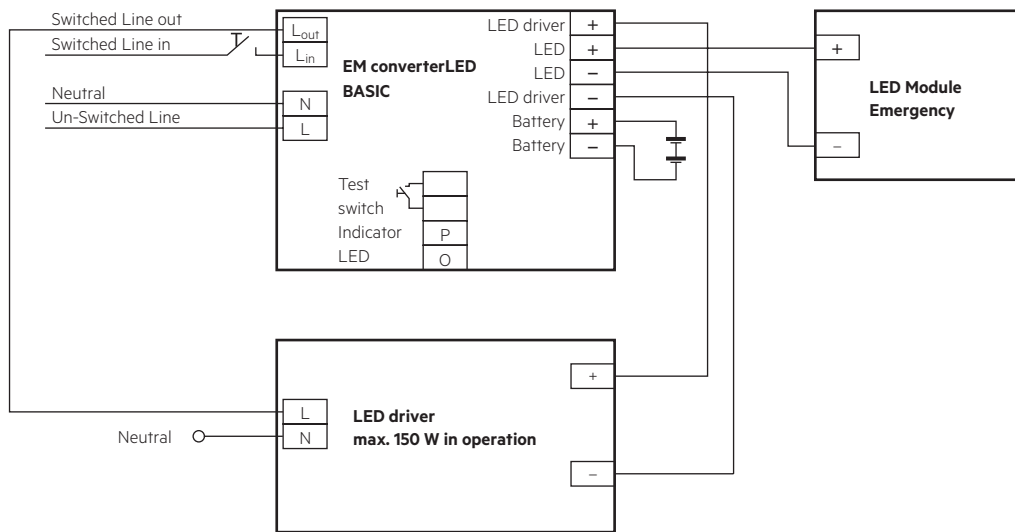

EM converterLED BASIC with a standard LED driver and series operation of LED modules

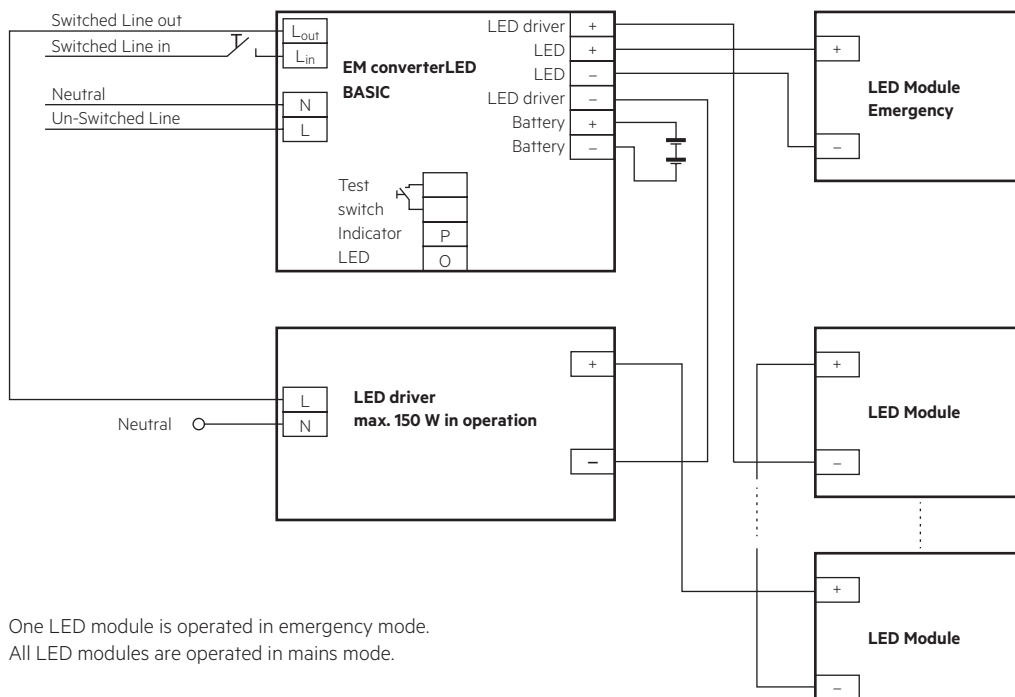

One LED module is operated in emergency mode.
All LED modules are operated in mains mode.

EM converterLED BASIC with a standard LED driver and series operation of LED modules

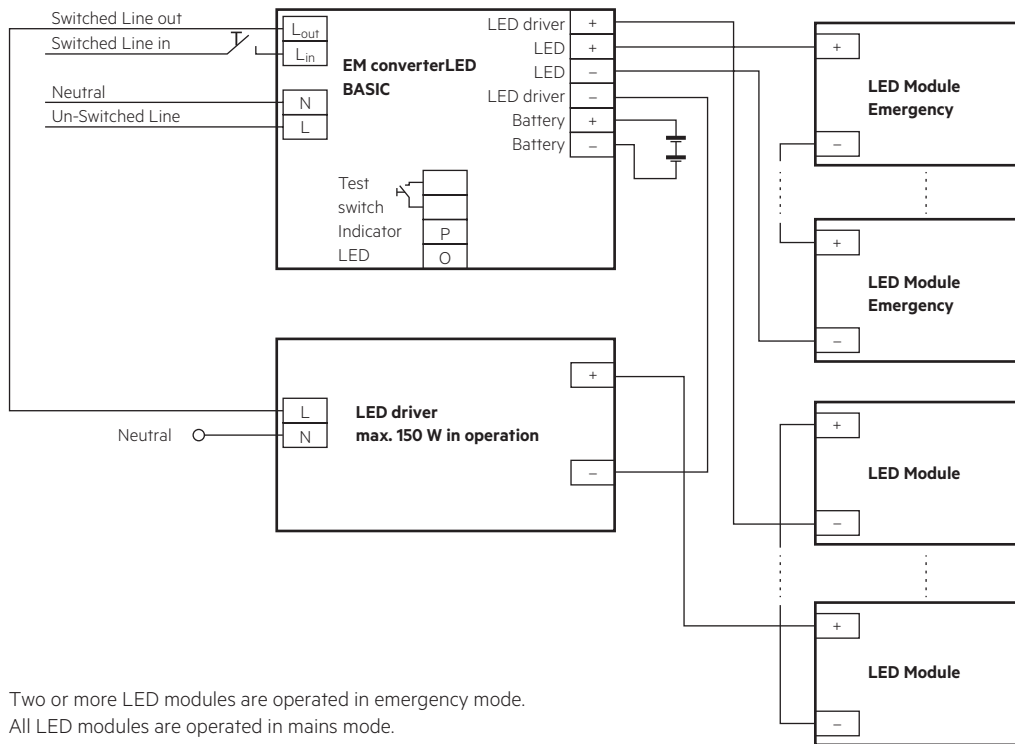

EM converterLED BASIC with a standard LED driver and parallel operation of LED modules

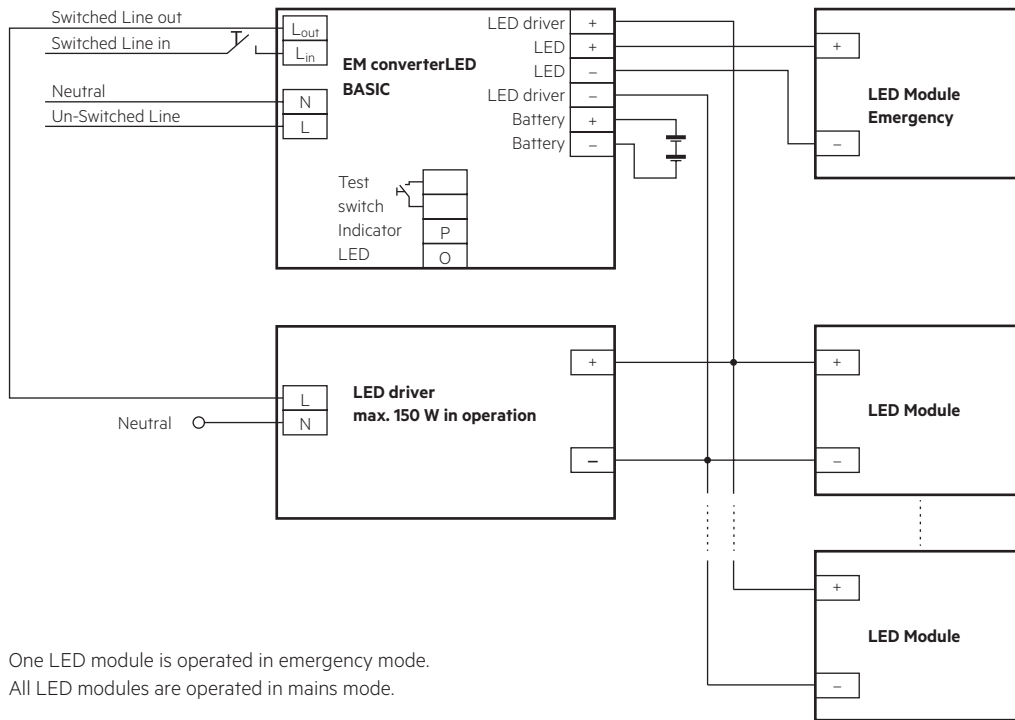

EM converterLED BASIC with a standard LED driver and parallel operation of LED modules

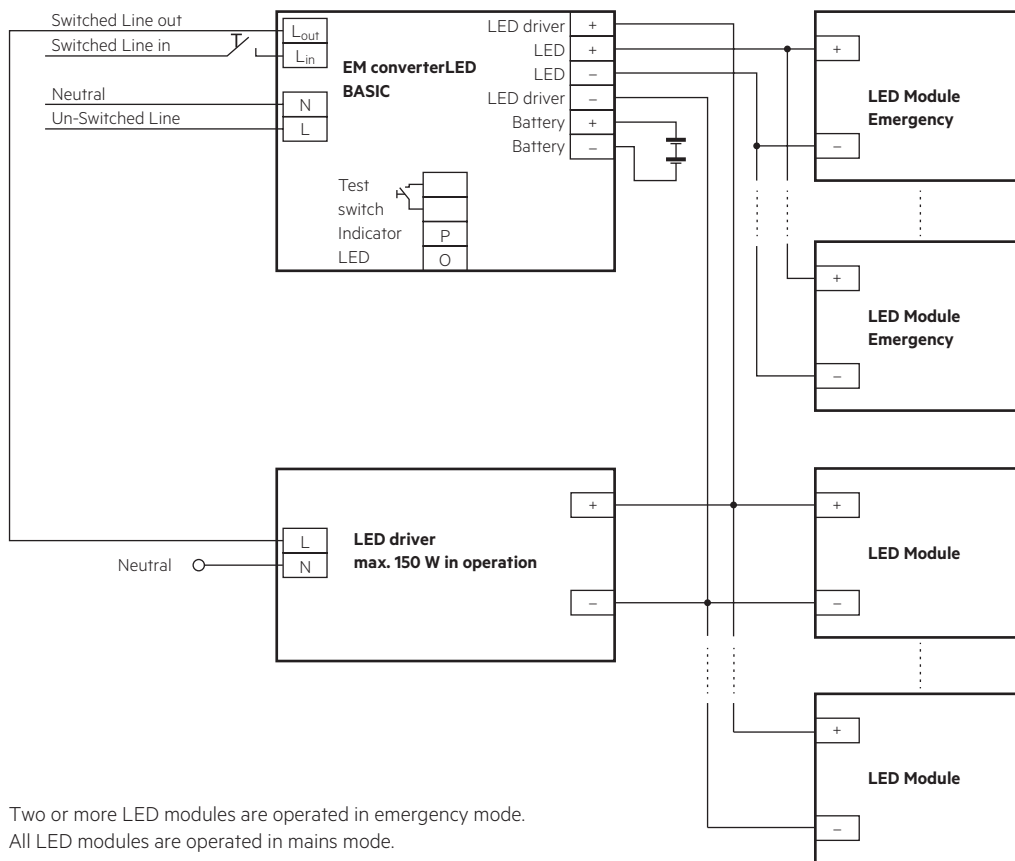

Two or more LED modules are operated in emergency mode.
All LED modules are operated in mains mode.

3.2 Wiring type and cross section

Solid wire with a cross section of 0.5 – 1.5 mm². Strip 8 – 9 mm of insulation from the cables to ensure perfect operation of terminals.

Wiring: LED module/LED driver/supply

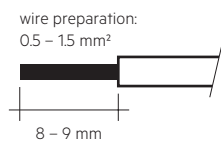

3.3 Loose wiring

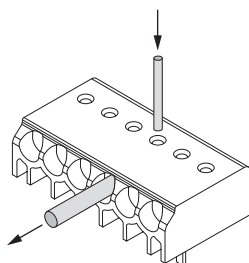

Loosen wire through twisting and pulling or using a Ø 1 mm release tool

3.4 Wiring guidelines

- The LED terminals, battery, indicator LED and test switch terminals are classified as SELV (output voltage < 120 V DC). Keep the wiring of the input terminals separated from the wiring of the SELV classified terminals or consider special wiring (double insulation, 6 mm creepage and clearance) when these connections should be kept SELV.
- The output to the LED is DC but has high frequency content, which should be considered for good EMC compliance.
- Separate LED leads from the mains and DALI connections and wiring for good EMC performance.
- Maximum lead length on the LED terminals is 3 m. For a good EMC performance keep the LED wiring as short as possible.
- Route the secondary wires (LED module) in parallel to ensure good EMC performance.
- Maximum lead length for the Test switch and Indicator LED connection is 1 m. Separate the test switch and Indicator LED wiring from the LED leads to prevent noise coupling.
- Battery leads are specified with 0.5 mm cross section and a length of 1.3 m
- Protect the wiring against short circuits to earth (sharp edged metal parts, metal cable clips, louver, etc.) to avoid the damage of the control gear.

To ensure that a luminaire containing LED emergency units complies with EN 55015 for radio frequency conducted interference in both normal and emergency mode it is essential to follow good practice in the wiring layout.

Within the luminaire route the switched and unswitched 50 Hz supply wiring as short as possible and keep it as far away as possible from the LED leads. Through wiring may affect the EMC performance of the luminaire.

Do not exceed the max. length of LED leads to the LED module. Note that the length of the EM converterLED leads to the LED module is added to the length of the leads from the LED driver to the EM converterLED module when considering the max. permitted lead length of the LED driver.

3.5 Maximum lead length

LED	3 m (6 m loop)
Status indication LED	1 m
Batteries	1.3 m

3.6 Use of different phases

The use of different phases for switched line and unswitched line is allowed. When using different phases, the unswitched line must fail if the switched line fails. This is required to assure correct switching into emergency mode. It can be realised with a relay.

4. Mechanical values

4.1 Housing properties

- Casing manufactured from polycarbonate.
- Type of protection: IP20
- Max. torque at the mounting screws: 0.8 Nm

4.2 Mechanical data accessories

LED status indicator

- Green
- Mounting hole 6.5 mm diameter, 1 – 1.6 thickness
- Lead length 0.3 m / 0.6 m / 1.0 m
- Insulation rating: 90 °C
- Plug connection

Test switch

- Mounting hole 7.0 mm diameter
- Lead length 0.55 m
- Plug connection

Battery leads

- Quantity: 1 red and 1 black
- Length: 1.3 m
- Wire type: 0.5 mm² solid conductor
- Insulation rating: 90 °C

Battery end termination

Push on 4.8 mm receptacle to suit battery
spade fitted with insulating cover

Module end termination

8.0 mm stripped insulation

Two-piece batteries are supplied with a 200 mm lead with 4.8 mm receptacle at each end and insulating covers to connect the separate sticks together.

5. Electrical values

5.1 Maximum loading of automatic circuit breakers

Automatic circuit breaker type	B10	B13	B16	B20	C10	C13	C16	C20	Inrush current	
	Installation Ø	1.5 mm ²	1.5 mm ²	1.5 mm ²	2.5 mm ²	1.5 mm ²	1.5 mm ²	1.5 mm ²	2.5 mm ²	I _{max}
EM converterLED BASIC 203 NiCd/NiMH 90V	90	130	130	130	180	260	260	260	10 A	120 µs
EM converterLED BASIC 204 NiCd/NiMH 90V	90	130	130	130	180	260	260	260	10 A	120 µs

5.2 Insulation matrix

	Mains	Switched Live	Battery, LED, Test switch, Indicator LED	LED driver
Mains	-	•	••	•
Switched Live	•	-	••	•
Battery, LED, Test switch, Indicator LED	••	••	-	-
LED driver	•	•	-	-

• Represents basic insulation

•• Represents double or reinforced insulation

When using a non-SELV LED driver insulate the battery, LED, test switch and indicator LED in the luminaire according to the U-OUT rating of the LED driver.

5.3 Typ. LED current/voltage characteristics

The LED current in emergency mode is automatically adjusted by the EM converterLED module based on the total forward voltage of the LED modules connected and the associated battery. The start of the LED in emergency mode does not result in a current peak.

EM converterLED BASIC 203 NiCd/NiMH 90V

Article number: 89800561

3.6 V battery voltage

850 – 960 mA battery discharge current (tolerance)

EM converterLED BASIC 204 NiCd/NiMH 90V

Article number: 89800562

4.8 V battery voltage

850 – 960 mA battery discharge current (tolerance)

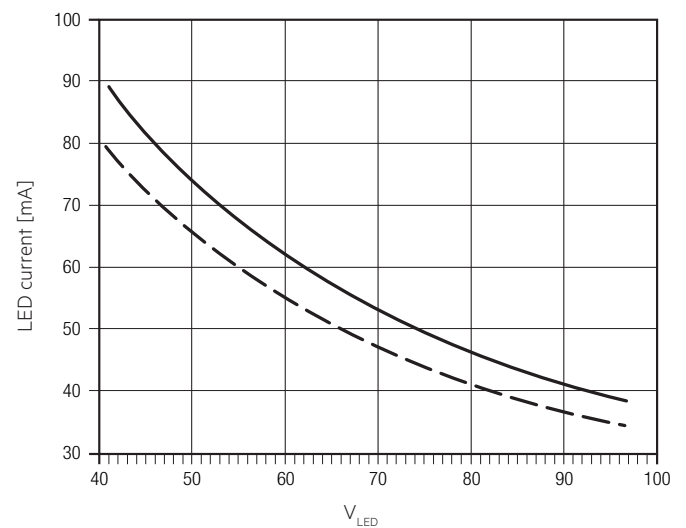
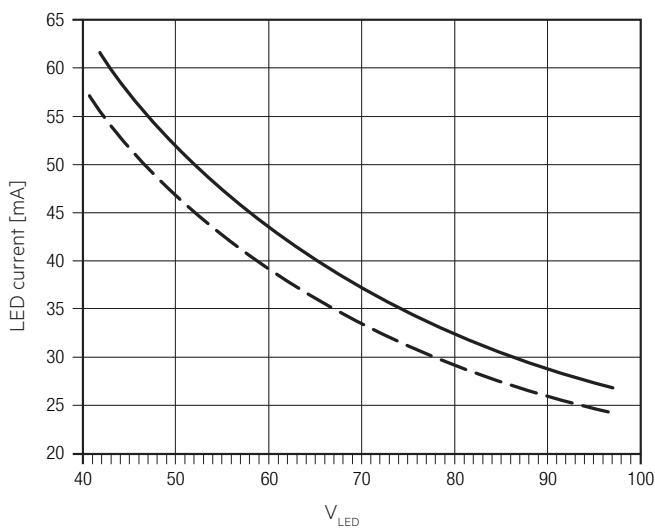

--- LED current at nominal battery voltage and min. battery discharge current

— LED current at nominal battery voltage and max. battery discharge current

5.4 LED driver compatibility



The EM converterLED emergency unit use 3 pole technology and is compatible with most LED drivers on the market, however it is important to check that the rating of the LED driver does not exceed the values specified below:

- The max. allowed output current rating of the associated LED driver is 2 A eff (current rating of the terminals of EM converterLED) and 2.4 A peak (current rating of switching relays of EM converterLED)
- The max. allowed inrush current rating of the associated LED driver is 60 A peak for 1 ms or 84 A for 255 μs (inrush current rating of switching relay of EM converterLED)
- The max. allowed output voltage (U-OUT) of the associated LED driver applied to the EM converterLED output is 450 V (voltage withstand between adjacent contact of the single switching relay of the EM converterLED)
- The max. allowed LED load of the associated LED driver is 150 W in operation. The load must be an LED module.

Check compatibility with short function tests (duration of several seconds).

6. Functions

6.1 Duration link selection

Duration	Usage duration link
3 h	 <p>With link</p>
1 h	 <p>Without link</p>

Emergency lighting LED driver supplied with duration link in 3 hours position.

The position of the link will only be read on first power up. If it is changed afterwards both the battery and mains supply must be disconnected for 10 seconds to enable the EM converterLED to read the new link position on reconnection of the battery and mains. It will lead to a false battery failure indication if the link is changed after installation without this reset.

6.2 Status indication LED

System status is indicated by a green LED.

Note:

The status indication LED switches off if the battery does not reach the full capacity (3.6V battery voltage) within 20 – 24 hours. If this occurs disconnect the mains voltage and operate the device in emergency mode for approximately one hour. Afterwards apply the mains voltage again and recharge the battery for 24 hours. If the failure occurs again replace the battery.

7. Battery data

7.1 Battery selection

EM converterLED BASIC, 1 / 3 h

		Type	EM converterLED BASIC 203 NiCd/NiMH 90V		EM converterLED BASIC 204 NiCd/NiMH 90V	
		Article no.	89800561		89800562	
		Cells	3 cells		4 cells	
		Duration	1 h	3 h	1 h	3 h
Technology and capacity	Design	Number of cells	Type	Article no.	Assignable batteries	
NiCd 4 Ah D cells	stick	1 x 3	Accu-NiCd 3A 55	28002773	•	
	side by side	3 x 1	Accu-NiCd 3B 55	89800384	•	
	stick	1 x 4	Accu-NiCd 4A 55	89800089		•
	stick + stick	2 + 2	Accu-NiCd 4C 55	28002775		•
	side by side	4 x 1	Accu-NiCd 4B 55	89800385		•
	remote box	1 x 3	Pack-NiCd 3D CON	89800389	•	
	remote box	1 x 4	Pack-NiCd 4D CON	89800390		•
NiMH 2.2 Ah Cs cells	stick	1 x 3	Accu-NiMH 3A	28002088	•	
	stick	1 x 4	Accu-NiMH 4A	28002089		•
	remote box	1 x 3	Pack-NiMH 2.2Ah 3 CON	28001898	•	
	remote box	1 x 4	Pack-NiMH 2.2Ah 4 CON	28001899		•
NiMH 4 Ah LA cells	stick	1 x 3	Accu-NiMH 4Ah 3A CON	89800441	•	
	stick	1 x 4	Accu-NiMH 4Ah 4A CON	89800442		•
	remote box	1 x 3	Pack-NiMH 4Ah 3 CON	28001896	•	
	remote box	1 x 4	Pack-NiMH 4Ah 4 CON	28001897		•

7.2 Battery charge / discharge data

EM converterLED BASIC, 1 / 3 h

		Type	EM converterLED BASIC 203 NiCd/NiMH 90V		EM converterLED BASIC 204 NiCd/NiMH 90V	
		Article no.	89800561		89800562	
		Cells	3 cells		4 cells	
		Duration	1 h	3 h	1 h	3 h
Battery charge time	Initial charge	24 h				
	Fast recharge	24 h				
	Trickle charge	continuously				
Charging current	Initial charge	80 – 130 mA	170 – 220 mA	80 – 130 mA	170 – 220 mA	
	Fast recharge	80 – 130 mA	170 – 220 mA	80 – 130 mA	170 – 220 mA	
	Trickle charge	45 – 95 mA	80 – 130 mA	45 – 95 mA	80 – 130 mA	
Discharge current		850 – 960 mA	850 – 960 mA	850 – 960 mA	850 – 960 mA	
Charge voltage range [®]		0.9 – 1.65 V per cell				
Discharge voltage range		1.65 – 0.90 V per cell				

[®] The battery will be charged below 0.9 V. The EM converterLED will indicate a battery fault.

The emergency lighting LED driver will recharge the battery normally after running the test of 61347-2-7 CL 22.3 (abnormal operating conditions).

7.3 Accu-NiCd**4.2 / 4.5 Ah**

International designation	KRMU 33/62
Battery voltage/cell	1.2 V
Cell type	D
Case temperature range to ensure 4 years design life	+5 °C to +55 °C
Max. short term battery case temperature (shorter than 1 month over the battery lifetime)	70 °C
Max. number discharge cycles	12 cycles per year plus 4 cycles during comissioning
Max. storage time	12 months

7.4 Accu-NiMH**2.2 Ah**

International designation	HRMU 23/43
Battery voltage/cell	1.2 V
Cell type	Cs
Case temperature range to ensure 4 years design life	+5 °C to +50 °C
Max. short term battery case temperature (shorter than 1 month over the battery lifetime)	70 °C
Max. number discharge cycles	4 cycles per year plus 30 cycles during comissioning
Max. storage time	12 months

4.0 Ah

International designation	HRMU 19/90
Battery voltage/cell	1.2 V
Cell type	LA
Case temperature range to ensure 4 years design life	+5 °C to +45 °C
Max. short term battery case temperature (shorter than 1 month over the battery lifetime)	70 °C
Max. number discharge cycles	4 cycles per year plus 30 cycles during comissioning
Max. storage time	12 months

7.5 Accupack-NiCd**4.5 Ah**

Battery voltage/cell	1.2 V
Cell type	D
Ambient temperature range to ensure 4 years design life tc point	+5 °C to +40 °C +45 °C
Max. short term battery case temperature (shorter than 1 month over the battery lifetime)	70 °C
Max. number discharge cycles	4 cycles per year plus 4 cycles during comissioning
Max. storage time	6 months

7.6 Accupack-NiMH**2.2 Ah**

Battery voltage/cell	1.2 V
Cell type	Cs
Ambient temperature range to ensure 4 years design life tc point	+5 °C to +35 °C +40 °C
Max. short term battery case temperature (shorter than 1 month over the battery lifetime)	70 °C
Max. number discharge cycles	4 cycles per year plus 4 cycles during comissioning
Max. storage time	12 months

4.0 Ah

Battery voltage/cell	1.2 V
Cell type	LAL
Ambient temperature range to ensure 4 years design life tc point	+5 °C to +35 °C +40 °C
Max. short term battery case temperature (shorter than 1 month over the battery lifetime)	70 °C
Max. number discharge cycles	4 cycles per year plus 4 cycles during comissioning
Max. storage time	12 months

For a higher battery temperature rating for NiMH 4 Ah refer to the EM converterLED xx MH/LiFePO4 product range.

7.7 Wiring batteries

To inhibit inverter operation disconnect the batteries by removing the connection at battery side.

For further informations refer to corresponding battery datasheet.

7.8 Storage, installation and commissioning

Relevant information about storage conditions, installation and commissioning are provided in the battery datasheets.

8. Miscellaneous**8.1 Maximum number of switching cycles**

EM converterLEDs are tested with 50,000 mains switching cycles of the associated LED driver.

8.2 Battery replacement

After a battery replacement and a subsequent full charge cycle (24 h) a duration test is mandatory to prove that with the new battery the rated duration is achieved.

8.3 Mains-connected transformers

The EM converterLED does not contain mains-connected windings of transformers.

8.4 Additional information

Additional technical information at www.tridonic.com → Technical Data

Lifetime declarations are informative and represent no warranty claim. No warranty if device was opened.