

**EM converterLED BASIC MH/LiFePO4 90 V**

Ausführung BASIC

**Product description**

- \_ Self contained emergency lighting LED driver for manual testing
- \_ For LED modules with a forward voltage of 40 – 97 V
- \_ SELV for output voltage < 120 V DC
- \_ Low profile casing (21 x 30 mm cross-section)
- \_ For luminaire installation
- \_ EM = Emergency
- \_ Nominal lifetime up to 100,000 h
- \_ 5 years guarantee (conditions at <https://www.tridonic.com/en/int/services/manufacturer-guarantee-conditions>)

**Properties**

- \_ Non maintained operation
- \_ 1 or 3 h rated duration
- \_ Operating time selectable with plug (duration link)
- \_ Compatible with all dimmable and non-dimmable constant current LED driver (see data sheet, LED driver compatibility)
- \_ 3-pole technology: 2-pole LED module changeover and delayed power switching for the LED driver
- \_ Automatic shutdown of output if LED load is out of range
- \_ Constant power output
- \_ Maximum light output for all LED modules
- \_ Electronic charge system
- \_ Deep discharge protection
- \_ Short-circuit-proof battery connection
- \_ Polarity reversal protection for battery provided by 3-pole connector
- \_ Automatic detection of the connected battery technology (NiMH or LiFePO4 batteries)

**Batteries**

- \_ High-temperature cells
- \_ NiMH or LiFePO4 batteries
- \_ 18650 cells or 26650 cells
- \_ NiMH: 4 years design life / 2 years guarantee (conditions at <https://www.tridonic.com/en/int/services/manufacturer-guarantee-conditions>)
- \_ LiFePO4: up to 12 years design life
- \_ LiFePO4 batteries with Tridonic LiFeGuard
- \_ For battery compatibility refer to data sheet, battery selection
- \_ For guarantee conditions, see LiFePO4 battery data sheet (conditions at <https://www.tridonic.com/en/int/services/manufacturer-guarantee-conditions>)

**Website**

<http://www.tridonic.com/89800578>



**EM converterLED BASIC MH/LiFePO4 90 V**

Ausführung BASIC

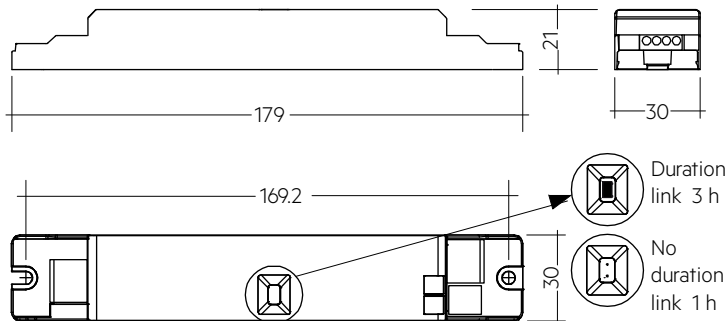

Note: Supply of control gear with duration link in 3 hours position. Remove duration link for duration of 1 h. Duration link must be set before battery and mains connection.

**Ordering data**

Type	Article number	Rated duration	Packaging, carton	Packaging, pallet	Weight per pc.	Dimensions L x W x H
EM converterLED BASIC 203 MH/LiFePO4 90V	89800578	1/3 h	10 pc(s).	1,600 pc(s).	0.07 kg	179 x 30 x 21 mm
EM converterLED BASIC 204 MH/LiFePO4 90V	89800579	1/3 h	10 pc(s).	1,600 pc(s).	0.07 kg	179 x 30 x 21 mm

**Technical data**

Rated supply voltage	220 – 240 V
AC voltage range	198 – 264 V
Mains frequency	50 / 60 Hz
Forward voltage range LED module	40 – 97 V
Output current	Refer to data sheet
Starting time	< 0.5 s from detection of emergency event
Overvoltage protection	320 V (for 48 h)
U-OUT (including open- / short-circuit and double load)	120 V
Max. open circuit voltage	120 V
Battery charging time <sup>①②</sup>	24 h
Ambient temperature ta	-5 ... +55 °C
Max. casing temperature tc	75 °C
Mains voltage changeover threshold	According to EN 60598-2-22
Mains surge capability (between L - N)	1 kV
Mains surge capability (between L/N - PE)	2 kV
Type of protection	IP20
Lifetime	up to 100,000 h
Guarantee (conditions at www.tridonic.com)	5 Year(s)
Dimensions L x W x H	179 x 30 x 21 mm

**Approval marks**



**Standards**

according to EN 50172, according to EN 60598-2-22, EN 61347-1, EN 61347-2-13, EN 61347-2-7, EN 55015, EN 61000-3-2, EN 61000-3-3, EN 61547, EN 60068-2-64, EN 60068-2-29, EN 60068-2-30, EN 62384

Specific technical data

Type	Battery technology	Rated duration	Typ. $\lambda$ (at 230 V, 50 Hz)	Typ. output power P <sub>emergency</sub>	Mains current in charging operation			Mains power in charging operation		
					Initial charge	Fast recharge	Trickle charge <sup>®</sup>	Initial charge	Fast recharge	Trickle charge <sup>®</sup>
<b>EM converterLED BASIC 203 MH/LiFePO4 90V</b>	NiMH	1 h	0.60C	2.5 W	18 mA	18 mA	18 / 12 mA	2.6 W	2.6 W	2.6 / 1.4 W
<b>EM converterLED BASIC 203 MH/LiFePO4 90V</b>	NiMH	3 h	0.60C	2.5 W	21 mA	21 mA	21 / 12 mA	3.3 W	3.3 W	3.3 / 1.4 W
<b>EM converterLED BASIC 203 MH/LiFePO4 90V</b>	LiFePO4	1 h	0.60C	3.1 W	20 mA	20 mA	20 / 12 mA	2.8 W	2.8 W	2.8 / 1.4 W
<b>EM converterLED BASIC 203 MH/LiFePO4 90V</b>	LiFePO4	3 h	0.60C	3.1 W	25 mA	25 mA	25 / 12 mA	3.9 W	3.9 W	3.9 / 1.4 W
<b>EM converterLED BASIC 204 MH/LiFePO4 90V</b>	NiMH	1 h	0.65C	3.5 W	18 mA	18 mA	18 / 12 mA	2.6 W	2.6 W	2.6 / 1.4 W
<b>EM converterLED BASIC 204 MH/LiFePO4 90V</b>	NiMH	3 h	0.65C	3.5 W	21 mA	21 mA	21 / 12 mA	3.3 W	3.3 W	3.3 / 1.4 W
<b>EM converterLED BASIC 204 MH/LiFePO4 90V</b>	LiFePO4	1 h	0.65C	3.8 W	20 mA	20 mA	20 / 12 mA	2.8 W	2.8 W	2.8 / 1.4 W
<b>EM converterLED BASIC 204 MH/LiFePO4 90V</b>	LiFePO4	3 h	0.65C	3.8 W	25 mA	25 mA	25 / 12 mA	3.9 W	3.9 W	3.9 / 1.4 W

① 16 h battery charging time for 2 h emergency lighting function according to AS 2293.

② 12 h battery charging time for 2 h emergency lighting function when used with LiFePO4 batteries.

③ In case of NiMH batteries: Intermittent charge is used. Value 1 is for 4 min. charge on / Value 2 is for 16 min. charge off. In case of LiFePO4 batteries voltage dependent constant current charging is used.

EMcLED Strain-relief set 240x43x30mm

Accessory

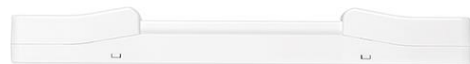

**Product description**

- \_ Optional strain-relief for independent applications
- \_ Transforms the LED driver into a fully class II compatible LED driver (e.g. ceiling installation)
- \_ Easy and tool-free mounting to the LED driver, screwless cable-clamp channels with strain-relief (240 x 43 x 30 mm)

**Website**

<http://www.tridonic.com/28003813>



## Emergency lighting units

EM converterLED

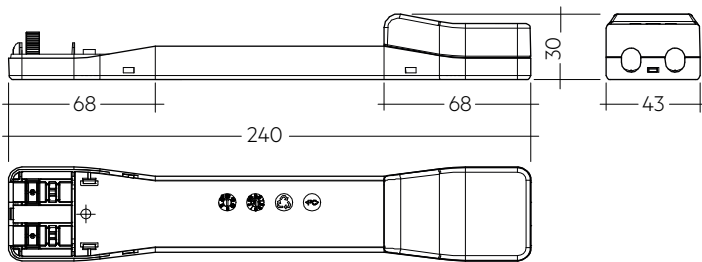

Permissible cable jacket diameter 2.2 – 9 mm

### Ordering data

Type	Article number	Packaging, carton	Weight per pc.
EM cLED SR	28003813	10 pc(s).	0.08 kg

### Approval marks



## Test switch EM3

Accessory



### Product description

- \_ For connection to the emergency lighting unit
- \_ For checking the device function
- \_ Plug connection
- \_ Dielectric strength: 1,500 V AC for 60 seconds
- \_ Lead length 0.55m
- \_ Mounting hole 7,0 mm diameter

### Website

<http://www.tridonic.com/89899956>



### Ordering data

Type	Article number	Packaging, bag	Packaging, carton	Weight per pc.
Test switch EM 3	89899956	25 pc(s).	2,000 pc(s).	0.01 kg

### Approval marks

RoHS

## Status indication green LED EM CON

Accessory



## Product description

- \_ A green LED indicates that charging current is flowing into the battery
- \_ 0.3 / 1.0 m cable length
- \_ Plug connection

## Website

<http://www.tridonic.com/89800269>



## Ordering data

Type	Article number	Packaging, bag	Packaging, carton	Weight per pc.
LED EM green, 1.0 m CON	<b>89800269</b>	25 pc(s).	800 pc(s).	0.018 kg
LED EM green, HO 1.0 m CON	<b>89800271</b>	25 pc(s).	200 pc(s).	0.016 kg
LED EM green, 0.6 m CON	<b>89800472</b>	25 pc(s).	200 pc(s).	0.010 kg
LED EM green, HO 0.6 m CON	<b>89800473</b>	25 pc(s).	200 pc(s).	0.010 kg
LED EM green, 0.3 m CON	<b>89800270</b>	25 pc(s).	200 pc(s).	0.007 kg
LED EM green, HO 0.3 m CON	<b>89800272</b>	25 pc(s).	200 pc(s).	0.007 kg

## Connection cable LiFePO4

Accessory



## Product description

- \_ Extension cable for LiFePO4 batteries
- \_ Cable length 500 mm
- \_ 3-pole plug connection

## Website

<http://www.tridonic.com/28002461>



## Ordering data

Type	Article number	Packaging, bag	Packaging, carton	Weight per pc.
EXTENSION CABLE LiFePO4 500mm	<b>28002461</b>	10 pc(s).	200 pc(s).	0.011 kg

Connection cable NiMH

Accessory



**Product description**

- \_ Connection cable for NiMH batteries
- \_ Cable length 500 mm
- \_ 2-pole plug connection for batteries and 3-pole plug connection for LED driver

**Website**

<http://www.tridonic.com/28002462>



**Ordering data**

Type	Article number	Packaging, bag	Packaging, carton	Weight per pc.
CONNECTION CABLE NiMH 500mm	28002462	10 pc(s).	200 pc(s).	0.01 kg

## 1. Standards

- EN 61347-1
- EN 61347-2-13
- EN 61347-2-7
- EN 55015
- EN 61000-3-2
- EN 61000-3-3
- EN 61547
- EN 60068-2-64
- EN 60068-2-29
- EN 60068-2-30
- EN 62384
- according to EN 50172
- according to EN 60598-2-22

Meaning of marking 

Double or reinforced insulation for built-in electronic LED drivers. The control gear relies upon the luminaire enclosure for protection against accidental contact with live parts.

### 1.1 Glow-wire test

according to EN 61347-1 with increased temperature of 850 °C passed.

### 1.2 Insulation and electric strength testing of luminaires

Electronic LED-drivers can be damaged by high voltage. This has to be considered during the routine testing of the luminaires in production.

According to IEC 60598-1 Annex Q (informative only!) or ENEC 303-Annex A, each luminaire should be submitted to an insulation test with 500 V<sub>dc</sub> for 1 second. This test voltage should be connected between the interconnected phase and neutral terminals and the earth terminal. The insulation resistance must be at least 2 MΩ.

As an alternative, IEC 60598-1 Annex Q describes a test of the electrical strength with 1,500 V<sub>AC</sub> (or 1,414 x 1,500 V<sub>DC</sub>). To avoid damage to the electronic devices this test **must not be conducted**.

## 2. Thermal details and lifetime

### 2.1 Lifetime

Average lifetime 50,000 hours under rated conditions with a failure rate of less than 10 %. Average failure rate of 0.2 % per 1000 operating hours.

#### Expected lifetime with NiMH batteries

<b>EM converterLED BASIC 203</b>	tc	65 °C	70 °C	75 °C
<b>MH/LiFePO4 90V</b>	lifetime	> 100,000 h	> 100,000 h	82,000 h
<b>EM converterLED BASIC 204</b>	tc	65 °C	70 °C	75 °C
<b>MH/LiFePO4 90V</b>	lifetime	> 100,000 h	> 100,000 h	82,000 h

#### Expected lifetime with LiFePO<sub>4</sub> batteries

<b>EM converterLED BASIC 203</b>	tc	65 °C	70 °C	75 °C
<b>MH/LiFePO4 90V</b>	lifetime	> 100,000 h	> 100,000 h	89,000 h
<b>EM converterLED BASIC 204</b>	tc	65 °C	70 °C	75 °C
<b>MH/LiFePO4 90V</b>	lifetime	> 100,000 h	> 100,000 h	89,000 h

The emergency lighting LED driver is designed for a lifetime stated above under reference conditions and with a failure probability of less than 10 %.

The relation of tc to ta temperature depends also on the luminaire design. If the measured tc temperature is approx. 5 K below tc max., ta temperature should be checked and eventually critical components (e.g. ELCAP) measured. Detailed information on request.

## 3. Installation / Wiring

### 3.1 Wiring diagram

One or more LED modules with a total forward voltage of 40 to 97 V can be connected to the EM converterLED 90V module. These LED module(s), marked with "Emergency" are operated in emergency mode from the associated battery. In normal mains mode all LED modules are operated by the LED driver from the mains supply.

Use of the test switch:

For checking the device function press the test switch for a minimum of 3 seconds.

**EM converterLED BASIC with one LED module for non-maintained emergency operation**

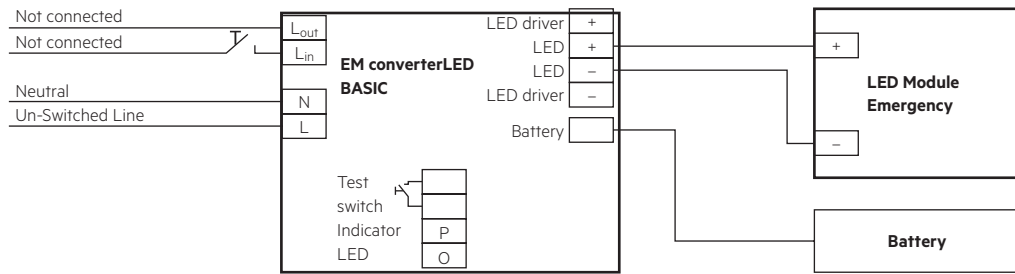

**EM converterLED BASIC with a standard LED driver and one LED module for mains and emergency operation**

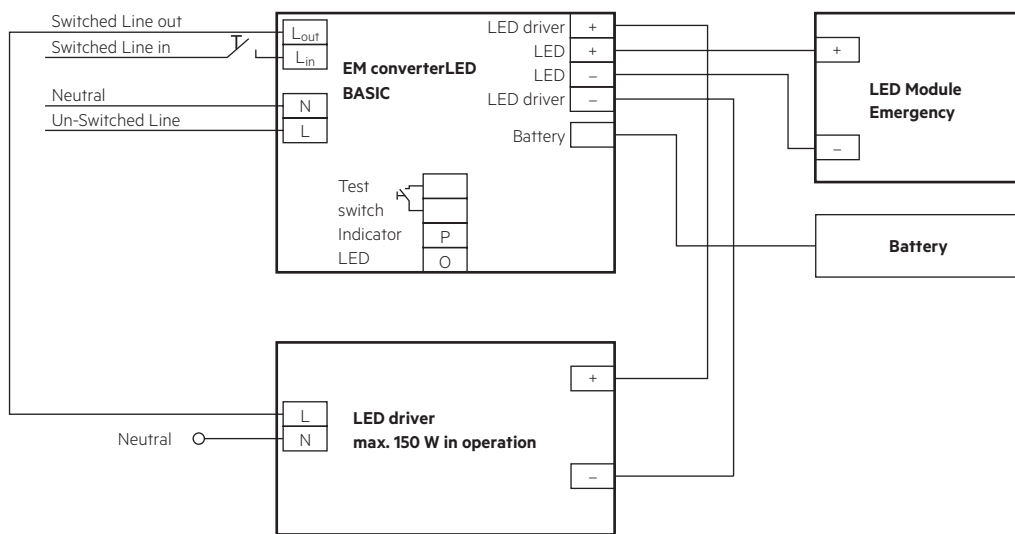

**EM converterLED BASIC with a standard LED driver and series operation of LED modules**

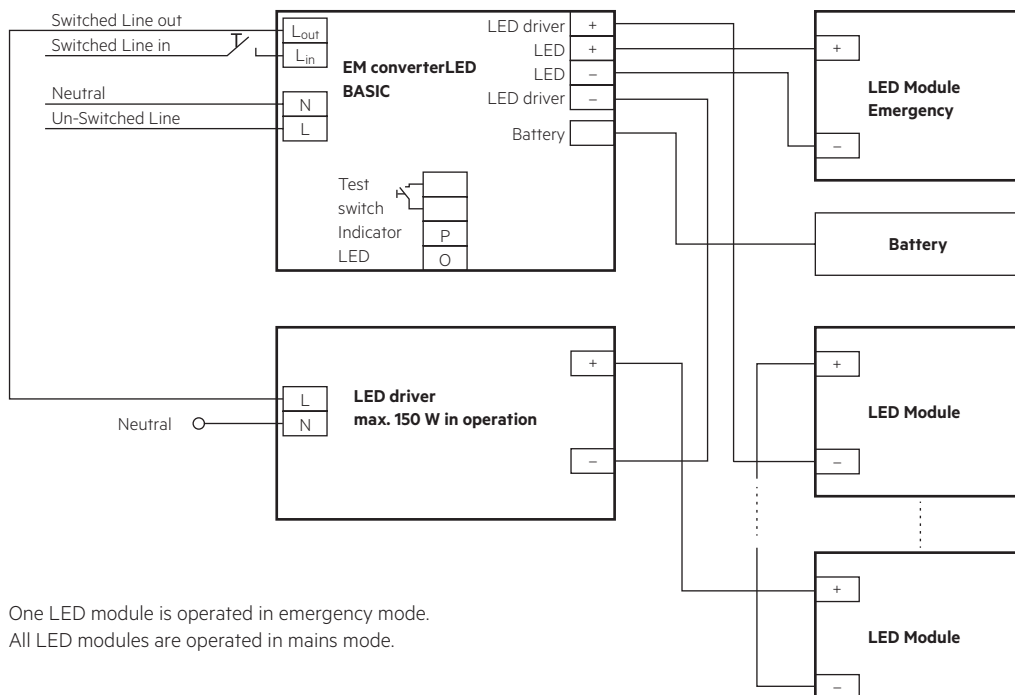

One LED module is operated in emergency mode.  
All LED modules are operated in mains mode.

**EM converterLED BASIC with a standard LED driver and parallel operation of LED modules**

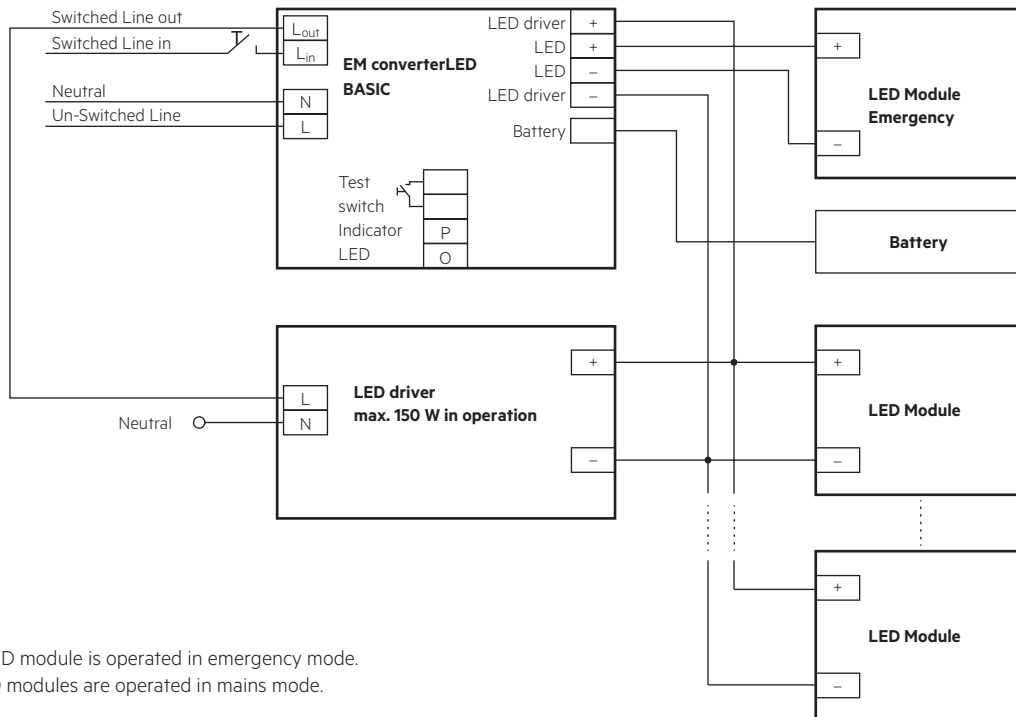

One LED module is operated in emergency mode.  
All LED modules are operated in mains mode.

**3.2 Wiring type and cross section**

Solid wire with a cross section of 0.5 – 1.5 mm<sup>2</sup>. Strip 8 – 9 mm of insulation from the cables to ensure perfect operation of terminals.

Wiring: LED module/LED driver/supply

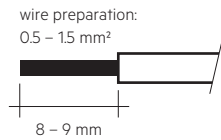

**3.3 Battery connection**

NiMH: Connection with extension

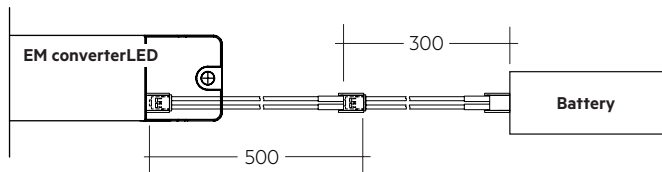

When using an EM converterLED in combination with a NiMH battery, order the CONNECTION CABLE NiMH 500mm separately.

LiFePO<sub>4</sub>: Direct connection

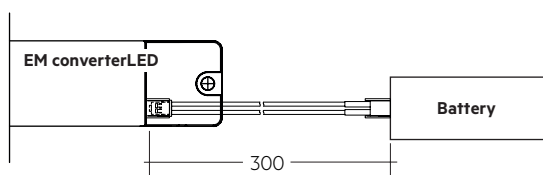

LiFePO<sub>4</sub>: Connection with extension

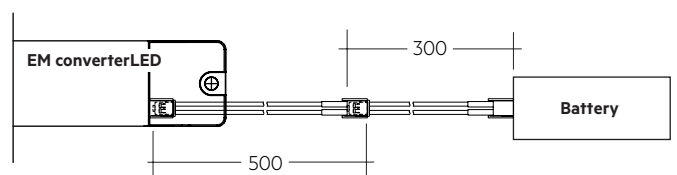

### 3.4 Loose wiring

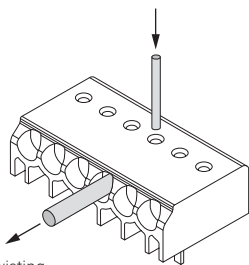

Loosen wire through twisting and pulling or using a  $\varnothing$  1 mm release tool

### 3.5 Wiring guidelines

- The LED terminals, battery, indicator LED and test switch terminals are classified as SELV (output voltage < 120 V DC). Keep the wiring of the input terminals separated from the wiring of the SELV classified terminals or consider special wiring (double insulation, 6 mm creepage and clearance) when these connections should be kept SELV.
- The output to the LED is DC but has high frequency content, which should be considered for good EMC compliance.
- Separate LED leads from the mains and DALI connections and wiring for good EMC performance.
- Maximum lead length on the LED terminals is 3 m. For a good EMC performance keep the LED wiring as short as possible.
- Route the secondary wires (LED module) in parallel to ensure good EMC performance.
- Maximum lead length for the Test switch and Indicator LED connection is 1 m. Separate the test switch and Indicator LED wiring from the LED leads to prevent noise coupling.
- Battery leads are specified with 0.5 mm cross section and a length of 0.8 m
- Protect the wiring against short circuits to earth (sharp edged metal parts, metal cable clips, louver, etc.) to avoid the damage of the control gear.

To ensure that a luminaire containing LED emergency units complies with EN 55015 for radio frequency conducted interference in both normal and emergency mode it is essential to follow good practice in the wiring layout.

Within the luminaire route the switched and unswitched 50 Hz supply wiring as short as possible and keep it as far away as possible from the LED leads. Through wiring may affect the EMC performance of the luminaire.

Do not exceed the max. length of LED leads to the LED module. Note that the length of the EM converterLED leads to the LED module is added to the length of the leads from the LED driver to the EM converterLED module when considering the max. permitted lead length of the LED driver.

### 3.6 Maximum lead length

LED	3 m (6 m loop) <sup>①</sup>
Status indication LED	1 m
Batteries	0.8 m

<sup>①</sup> Note: The length of LED leads to the LED module must not be exceeded. Note that the length of the EM converterLED leads is added to the length of the leads from the LED driver to the EM converterLED module when considering max. permitted lead length of the LED driver. Leads should always be kept as short as possible.

### 3.7 Use of different phases

The use of different phases for switched line and unswitched line is allowed. When using different phases, the unswitched line must fail if the switched line fails. This is required to assure correct switching into emergency mode. It can be realised with a relay.

## 4. Mechanical values

### 4.1 Housing properties

- Casing manufactured from polycarbonate.
- Type of protection: IP20
- Max. torque at the mounting screws: 0.8 Nm

### 4.2 Mechanical data accessories

LED status indicator

- Green
- Mounting hole 6.5 mm diameter, 1 – 1.6 mm thickness
- Lead length 0.3 m / 0.6 m / 1.0 m
- Insulation rating: 90 °C
- Plug connection

Test switch

- Mounting hole 7.0 mm diameter
- Lead length 0.55 m
- Plug connection

Battery connection

- Plug connection 0.3 m
- Extension 0.5 m

## 5. Electrical values

### 5.1 Maximum loading of automatic circuit breakers

Automatic circuit breaker type	B10	B13	B16	B20	C10	C13	C16	C20	Inrush current	
Installation Ø	1.5 mm <sup>2</sup>	1.5 mm <sup>2</sup>	1.5 mm <sup>2</sup>	2.5 mm <sup>2</sup>	1.5 mm <sup>2</sup>	1.5 mm <sup>2</sup>	1.5 mm <sup>2</sup>	2.5 mm <sup>2</sup>	I <sub>max</sub>	time
<b>EM converterLED BASIC MH/LiFePO4 90V</b>	90	130	130	130	180	260	260	260	10 A	120 µs

### 5.2 Insulation matrix

	Mains	Switched Live	Battery, LED, Test switch, Indicator LED	LED driver
<b>Mains</b>	-	•	••	•
<b>Switched Live</b>	•	-	••	•
<b>Battery, LED, Test switch, Indicator LED</b>	••	••	-	-
<b>LED driver</b>	•	•	-	-

- Represents basic insulation
- Represents double or reinforced insulation

When using a non-SELV LED driver insulate the battery, LED, test switch and indicator LED in the luminaire according to the U-OUT rating of the LED driver.

### 5.3 Typ. LED current/voltage characteristics

The LED current in emergency mode is automatically adjusted by the EM converterLED module based on the total forward voltage of the LED modules connected and the associated battery. The start of the LED in emergency mode does not result in a current peak.

EM converterLED BASIC 203 MH/LiFePO4 90V  
 Article number: 89800578  
 NiMH battery, 3.6 V battery voltage  
 840 – 900 mA battery discharge current (tolerance)

EM converterLED BASIC 203 MH/LiFePO4 90V  
 Article number: 89800578  
 LiFePO<sub>4</sub> battery, 3.2 V battery voltage  
 1,150 – 1,250 mA battery discharge current (tolerance)

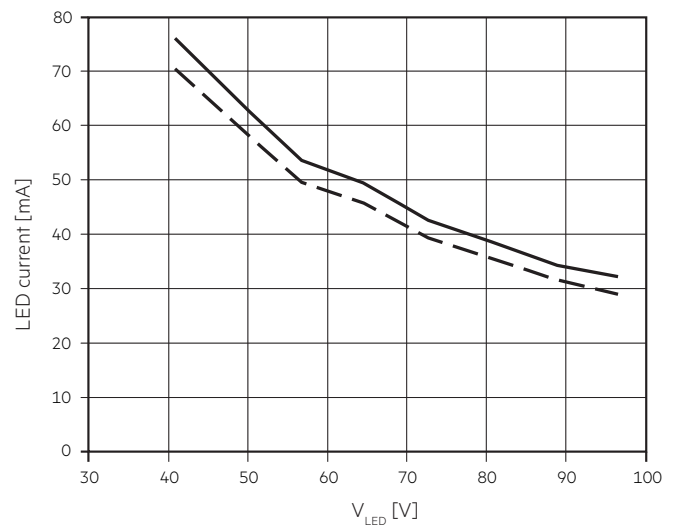
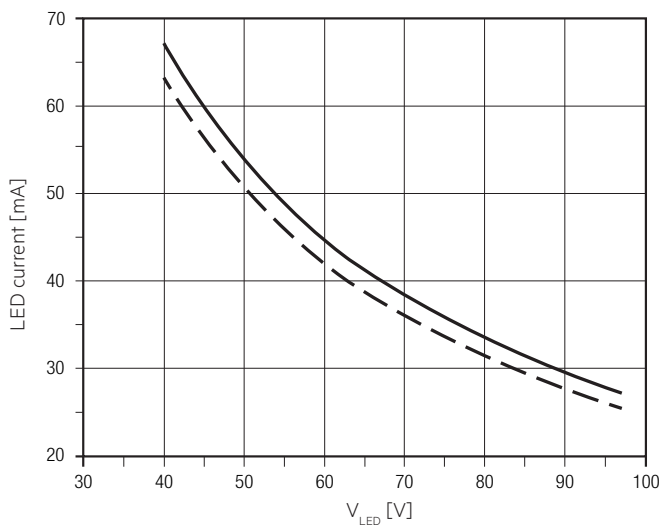

EM converterLED BASIC 204 MH/LiFePO4 90V  
 Article number: 89800579  
 NiMH battery, 4.8 V battery voltage  
 830 – 890 mA battery discharge current (tolerance)

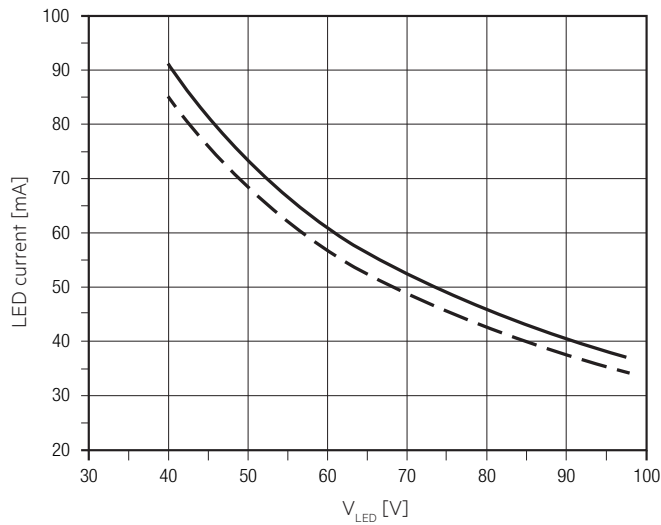

EM converterLED BASIC 204 MH/LiFePO4 90V  
 Article number: 89800579  
 LiFePO<sub>4</sub> battery, 3.2 V battery voltage  
 1,450 – 1,550 mA battery discharge current (tolerance)

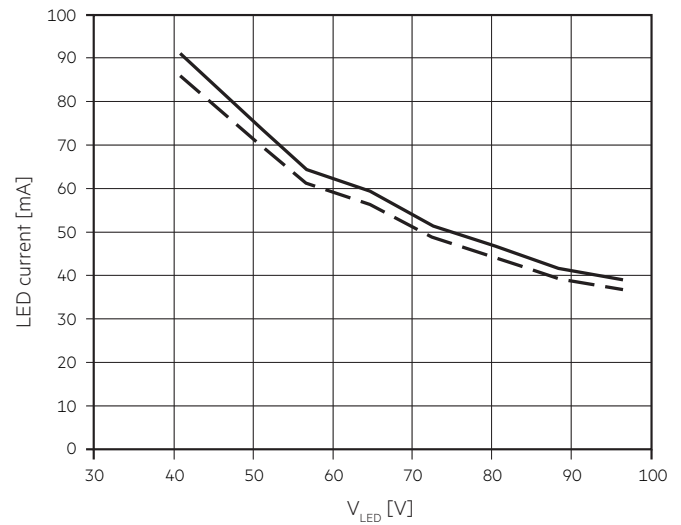

--- LED current at nominal battery voltage and min. battery discharge current  
 — LED current at nominal battery voltage and max. battery discharge current

**5.4 LED driver compatibility**



The EM converterLED emergency unit use 3 pole technology and is compatible with most LED drivers on the market, however it is important to check that the rating of the LED driver does not exceed the values specified below:

- The max. allowed output current rating of the associated LED driver is 2 A eff (current rating of the terminals of EM converterLED) and 2.4 A peak (current rating of switching relays of EM converterLED)
- The max. allowed inrush current rating of the associated LED driver is 60 A peak for 1 ms or 84 A for 255 μs (inrush current rating of switching relay of EM converterLED)
- The max. allowed output voltage (U-OUT) of the associated LED driver applied to the EM converterLED output is 450 V (voltage withstand between adjacent contact of the single switching relay of the EM converterLED)
- The max. allowed LED load of the associated LED driver is 150 W in operation. The load must be an LED module.

Check compatibility with short function tests (duration of several seconds).

**6. Functions**

**6.1 Duration link selection**

Duration	Usage duration link
3 h	 With link
1 h	 Without link

Emergency lighting LED driver supplied with duration link in 3 hours position.

The position of the link will only be read on first power up. If it is changed afterwards both the battery and mains supply must be disconnected for 10 seconds to enable the EM converterLED to read the new link position on reconnection of the battery and mains. It will lead to a false battery failure indication if the link is changed after installation without this reset.

**6.2 Status indication LED**

System status is indicated by a green LED.

Note:

The status indication LED switches off if the battery does not reach the full capacity (3.6V battery voltage) within 20 – 24 hours. If this occurs disconnect the mains voltage and operate the device in emergency mode for approximately one hour. Afterwards apply the mains voltage again and recharge the battery for 24 hours. If the failure occurs again replace the battery.

## 7. Battery data

### 7.1 Battery selection

EM converterLED BASIC, 1 / 3 h

		Type	EM converterLED BASIC 203 MH/LiFePO4 90V		EM converterLED BASIC 204 MH/LiFePO4 90V	
		Article no.	89800578		89800579	
		Duration	1 h	3 h	1 h	3 h
Technology and capacity	Design	Number of cells	Type	Article no.	Assignable batteries	
NiMH 4.0 Ah LA cells	stick	1 x 3	Accu-NiMH 4Ah 3A CON	89800441	•	
	stick	1 x 4	Accu-NiMH 4Ah 4A CON	89800442		•
	stick + stick	2 + 2	Accu-NiMH 4Ah 4C CON	89800438		•
	remote box	1 x 3	Pack-NiMH 4Ah 3 CON	28001896	•	
	remote box	1 x 4	Pack-NiMH 4Ah 4 CON	28001897		•
LiFePO <sub>4</sub> 1,5 Ah 18650 cells	stick	1 x 1	Accu-LiFePO4 1A CON	28002317		
	stick	1 x 2	Accu-LiFePO4 2A CON	28002318	•	•
	stick	1 x 4	Accu-LiFePO4 4A CON	28002322		•
	stick	1 x 5	Accu-LiFePO4 5A CON	28002325		•
	stick + stick	2 + 2	Accu-LiFePO4 4C CON	28002324	•	
	stick + stick	2 + 3	Accu-LiFePO4 5C CON	28002327		•
	side by side	2 x 1	Accu-LiFePO4 2B CON	28002319	•	•
	side by side	4 x 1	Accu-LiFePO4 4B CON	28002323	•	
	side by side	5 x 1	Accu-LiFePO4 5B CON	28002326		•
	remote box	1 x 2	PACK-LiFePO4 3.0Ah 2 CON	28003805	•	•
	remote box	1 x 3	PACK-LiFePO4 4.5Ah 3 CON	28003806		
	remote box	1 x 2	PACK-LiFePO4 3.0Ah 2 CON	28005854	•	•
	remote box	1 x 3	PACK-LiFePO4 4.5Ah 3 CON	28005855		
remote box	1 x 4	PACK-LiFePO4 6.0Ah 4 CON	28005856	•		
remote box	1 x 5	PACK-LiFePO4 7.5Ah 5 CON	28005857		•	
stick	1 x 2	Accu-LiFePO4 3.0 2A CON BAS	28006318	•	•	
stick	1 x 4	Accu-LiFePO4 6.0 4A CON BAS	28006320	•		
stick + stick	2 + 3	Accu-LiFePO4 7.5 5C CON BAS	28006321		•	
LiFePO <sub>4</sub> 3.3 Ah 26650 cells	stick	1S1P	Accu-LiFePO4 1A CON	28006323	•	•
	stick	1S2P	Accu-LiFePO4 2A CON	28006324	•	
	remote box	1S1P	PACK-LiFePO4 3.3Ah 1 CON	28005859	•	•

## 7.2 Battery charge / discharge data

## EM converterLED BASIC, 1 / 3 h, NiMH

Type	EM converterLED BASIC 203 MH/LiFePO4 90V		EM converterLED BASIC 204 MH/LiFePO4 90V			
	89800578		89800579			
Article no.						
Duration	1 h	3 h	1 h	3 h		
Battery charge time	Initial charge				24 h	
	Fast recharge				24 h	
	Trickle charge				continuously	
Charging current	Initial charge		110 – 150 mA	190 – 230 mA	110 – 150 mA	190 – 230 mA
	Fast recharge		110 – 150 mA	190 – 230 mA	110 – 150 mA	190 – 230 mA
	Trickle charge		110 – 150 mA / 4 min. 0 mA / 16 min.	190 – 230 mA / 4 min. 0 mA / 16 min.	110 – 150 mA / 4 min. 0 mA / 16 min.	190 – 230 mA / 4 min. 0 mA / 16 min.
Discharge current		840 – 900 mA	840 – 900 mA	830 – 890 mA	830 – 890 mA	
Charge voltage range <sup>®</sup>		0.9 – 1.65 V per cell				
Discharge voltage range		1.65 – 1.05 V per cell				

<sup>®</sup> The battery will be charged below 0.9 V. The EM converterLED will indicate a battery fault.

The emergency lighting LED driver will recharge the battery normally after running the test of 61347-2-7 CL 22.3 (abnormal operating conditions).

EM converterLED BASIC, 1 / 3 h, LiFePO<sub>4</sub>

Type	EM converterLED BASIC 203 MH/LiFePO4 90V		EM converterLED BASIC 204 MH/LiFePO4 90V			
	89800578		89800579			
Article no.						
Duration	1 h	3 h	1 h	3 h		
Battery charge time	Initial charge				24 h	
	Fast recharge				24 h	
	Trickle charge				continuously and battery voltage controlled	
Charging current	Initial charge		250 – 290 mA	430 – 470 mA	250 – 290 mA	430 – 470 mA
	Fast recharge		250 – 290 mA	430 – 470 mA	250 – 290 mA	430 – 470 mA
	Trickle charge <sup>®</sup>		250 – 290 mA / 0 mA	430 – 470 mA / 0 mA	250 – 290 mA / 0 mA	430 – 470 mA / 0 mA
Discharge current		1,150 – 1,250 mA	1,150 – 1,250 mA	1,450 – 1,550 mA	1,450 – 1,550 mA	
Charge voltage range <sup>®</sup>		2.0 – 3.65 V				
Discharge voltage range		3.65 – 2.60 V				

<sup>®</sup> Automatic recharge when battery voltage falls below 3.4 V. Charger off (0 mA) when battery voltage exceeds 3.6 V.

Note: Battery protected against operation at excessive temperatures (charging stopped when battery cell temperature < 0 °C or > 60 °C).

The emergency lighting LED driver will recharge the battery normally after running the test of 61347-2-7 CL 22.3 (abnormal operating conditions).

<sup>®</sup> The battery will not be charged below 2.0 V.

**7.3 Accu-NiMH****Capacity 4.0 Ah**

International designation	HRMU 19/90
Battery voltage/cell	1.2 V
Cell type	LA
Case temperature range to ensure 4 years design life	+5 °C to +50 °C
Max. short term battery case temperature (shorter than 1 month over the battery lifetime)	70 °C
Max. number discharge cycles	4 cycles per year plus 30 cycles during comissioning
Max. storage time	12 months at -20 °C to +25 °C

**7.4 Accu-LiFePO4****Capacity 1.5 Ah**

International designation	IFpR 19/66
Battery voltage/cell	3.2 V
Cell type	18650
Case temperature range to ensure 5 years design life	+5 °C to +60 °C
7 years design life	+5 °C to +55 °C
10 years design life	+5 °C to +45 °C
12 years design life	+5 °C to +35 °C
Max. short term battery case temperature (shorter than 1 month over the battery lifetime)	70 °C
Max. number discharge cycles	50 cycles total
Max. storage time	15 months at -20 °C to +35 °C

**7.5 Accupack-NiMH****Capacity 4.0 Ah**

Battery voltage/cell	1.2 V
Cell type	LAL
Ambient temperature range to ensure 4 years design life tc point	+5 °C to +35 °C +40 °C
Max. short term battery case temperature (shorter than 1 month over the battery lifetime)	70 °C
Max. number discharge cycles	4 cycles per year plus 4 cycles during comissioning
Max. storage time	12 months

**7.6 Accupack-LiFePO4****Capacity 1.5 Ah**

International designation	IFpR 19/66
Battery voltage/cell	3.2 V
Cell type	18650
Case temperature range to ensure 4 years design life	+5 °C to +45 °C
6 years design life	+5 °C to +35 °C
8 years design life	+5 °C to +25 °C
Max. short term battery case temperature (shorter than 1 month over the battery lifetime)	70 °C
Max. number discharge cycles	50 cycles total
Max. storage time	15 months at -20 °C to +35 °C

Only use Tridonic batteries.

Comply with UN 38.3 and IEC 62133 (safety testing) protected against over charge, over discharge, charging at excessive temperatures, short-circuit and over current.

**7.7 Accu / Accupack-LiFePO4****Capacity 3.3 / 6.6 Ah**

International designation	IFpR 27/66
Battery voltage/cell	3.2 V
Cell type	26650
Case temperature range to ensure 4 years design life	+5 °C to +45 °C
Max short term battery case tc point temperature (reduced lifetime)	70 °C
Max. number discharge cycles	50 cycles total
Max. storage time	15 months at -20 °C to +35 °C

**7.8 Accupack-LiFePO4****Capacity 3.3 Ah**

International designation	IFpR 27/66
Battery voltage/cell	3.2 V
Cell type	26650
Case temperature range to ensure 4 years design life	+5 °C to +45 °C
6 years design life	+5 °C to +35 °C
8 years design life	+5 °C to +25 °C
Max short term battery case tc point temperature (reduced lifetime)	70 °C
Max. number discharge cycles	50 cycles total
Max. storage time	15 months at -20 °C to +35 °C

**7.9 Accu-LiFePO4 BAS****Capacity 1.5 Ah**

International designation	IFpR 19/66
Battery voltage/cell	3.2 V
Cell type	18650
Case temperature range to ensure 4 years design life	+5 °C to +45 °C
Max short term battery case tc point temperature (reduced lifetime)	70 °C
Max. number discharge cycles	50 cycles total
Max. storage time	15 months at -20 °C to +35 °C

## 7.10 Safety (LiFeGuard)



Note: LiFeGuard ensures safe and reliable battery operation by offering a comprehensive three-layered safety system.

It addresses the cell, battery pack and emergency driver.

### 7.10.1 Deep discharge protection

When the battery remains connected without charging for a long period of time after the battery cut off of the driver the battery voltage can still drop. To make sure the cells are not damaged by this voltage drop, the battery protection prevents the battery from further discharge below 2.0 V.

### 7.10.2 Overcharge protection

If in case of an error or the use of a wrong driver the battery gets overcharged the battery protection will disconnect the battery from the driver at a voltage of 3.9 V. A discharge of the battery is still possible after the protection circuit was triggered to guarantee emergency operation.

### 7.10.3 Short-circuit protection

In case of a short circuit the battery protection opens the connection to the driver and the output is therefore free of voltage. The output will be reactivated again when the short circuit is removed.

### 7.10.4 Overtemperature protection

The battery is protected against temporary thermal overheating. If the temperature limit is exceeded the further charging of the battery is no longer possible. The temperature protection is activated below approx. 0 °C and above approx. +60 °C. The discharging of the battery is still possible to guarantee emergency operation. The charging is automatically activated when the temperature is within the range of 0 to 60°C again.



Battery has built in thermal sensor for safe charging. Mount battery away from heat source.

Positioning of the thermal sensor see battery data sheet.

## 7.11 Wiring batteries

To inhibit inverter operation disconnect the batteries by removing the connection at battery side.

For further informations refer to corresponding battery datasheet.

## 7.12 Storage, installation and commissioning

Relevant information about storage conditions, installation and commissioning are provided in the battery datasheets.

## 8. Miscellaneous

### 8.1 Maximum number of switching cycles

EM converterLEDs are tested with 50,000 mains switching cycles of the associated LED driver.

### 8.2 Battery replacement

After a battery replacement and a subsequent full charge cycle (24 h) a duration test is mandatory to prove that with the new battery the rated duration is achieved.

### 8.3 Mains-connected transformers

The EM converterLED does not contain mains-connected windings of transformers.

### 8.4 Additional information

Additional technical information at [www.tridonic.com](http://www.tridonic.com) → Technical Data

Lifetime declarations are informative and represent no warranty claim. No warranty if device was opened.