

EM R2A Exit Sign PRO 231 30m

EM ready2apply



Product description

- _ LED emergency exit sign suitable for various mounting options (ceiling, wall, flag, recessed, suspended)
- _ Independent and configurable pictogram
- _ Pictogram 'running man' and straight arrow included in delivery
- _ Diagonal arrow available as accessory
- _ Arrows are rotatable, so all directions can be achieved with default product + 1 accessory
- _ Emergency lighting function with DALI-2 interface and automatic test function
- _ EM = Emergency

Properties

- _ Viewing distance up to 30 m, double sided
- _ Non-maintained and maintained operation
- _ Very low stand-by power loss
- _ 3 h rated duration
- _ Breakable entrance holes at the back and top for 1 or 2 cables
- _ Simple connection of Lithium Iron Phosphate battery with plug-in system
- _ Integrated status LED
- _ 5 years guarantee electronic (LED driver) (conditions at <https://www.tridonic.com/en/int/services/manufacture-guarantee-conditions>)
- _ 5 years guarantee for LiFePO4 batteries (conditions at <https://www.tridonic.com/en/int/services/manufacture-guarantee-conditions>)

Website

<http://www.tridonic.com/89801283>



EM R2A Exit Sign PRO 231 30m

EM ready2apply

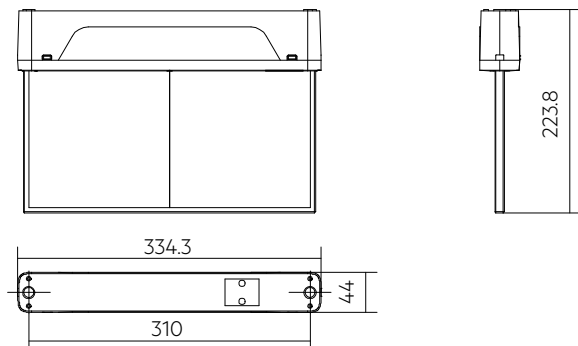

Ordering data

Type	Article number	Colour	Rated duration	Number of cells	Packaging, carton	Packaging, pallet	Weight per pc.
EM R2A Exit Sign PRO 231 30m	89801283	White	3 h	1	1 pc(s).	100 pc(s).	1.17 kg
EM R2A Exit Sign PRO 231 30m-B	89801287	Black	3 h	1	1 pc(s).	100 pc(s).	1.17 kg

Technical data

Rated supply voltage	220 – 240 V
Input voltage range AC (tolerance for safety)	198 – 264 V
Input voltage range AC (tolerance for performance)	198 – 254 V
Mains frequency	50 / 60 Hz
Overvoltage protection	320 V (for 48 h)
Starting time (Emergency operation)	< 0.5 s from detection of emergency event
Output current tolerance	± 10 %
LF current ripple	± 5 %
Ambient temperature range	+5 ... +40 °C
Mains voltage changeover threshold	According to EN 60598-2-22
Type of protection	IP40
Impact protection degree	IK03
Protection class	II
Lifetime	> 100,000 h

Approval marks



Standards

according to EN 50172, EN 55015, EN 60068-2-64, EN 60068-2-27, EN 60068-2-30, EN 60598-1, EN 60598-2-2, EN 60598-2-22, EN 61000-3-2, EN 61000-3-3, EN 61347-1, EN 61347-2-7, EN 61347-2-13, EN 61547, EN 62384, EN 62386-101, EN 62386-102, EN 62386-202, IEC 62620 (related to Lithium Iron battery), IEC 62133 (related to Lithium Iron battery), UN 38.3 (related to Lithium Iron battery), EN 62031, EN 62034, EN 62471, ISO 3864-1, ISO 3864-4, ISO 7010

Specific technical data

Type ^①	Rated duration	Number of LEDs	Typ. λ (at 230 V, 50 Hz)	Non-maintained operation		Maintained operation	
				Mains current in charging operation ^②	Mains power in charging operation ^②	Mains current in charging operation ^②	Mains power in charging operation ^②
EM R2A Exit Sign PRO 231 30m	3 h	24	0.58C	19 / 11 mA	2.1 / 0.6 W	35 / 23 mA	4.6 / 2.6 W
EM R2A Exit Sign PRO 231 30m-B	3 h	24	0.58C	19 / 11 mA	2.1 / 0.6 W	35 / 23 mA	4.6 / 2.6 W

① EM = Emergency

② For LiFePO₄ batteries voltage dependent constant current charging is used. The values displayed are for charging on / charging off.

LiFePO4 Battery pack 3.3 – 4.8 Ah

Accessory



ACCU-LiFePO4 4.8Ah 3B CON R2A 68MM

Product description

- _ High-temperature LiFePO4 cells only for use with Tridonic emergency lighting units
- _ 6 year design life (up to 30 °C ambient temperature)
- _ 4 year design life (up to 40 °C ambient temperature)
- _ 5 years guarantee (conditions at <https://www.tridonic.com/en/int/services/manufacture-guarantee-conditions>)

Properties

- _ Certified quality manufacturer
- _ Charge efficiency > 90 %
- _ Low self discharge
- _ Simple connection with plug-in system
- _ Protection and monitoring circuit built into battery enclosure
- _ Deep discharge protection
- _ Suitable for emergency lighting equipment as per IEC 60598-2-22

Website

<http://www.tridonic.com/28005688>

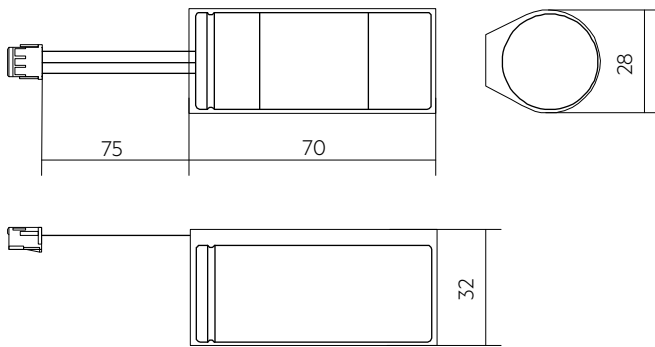

ACCU-LiFePO4 3.3Ah 1A CON R2A 68MM

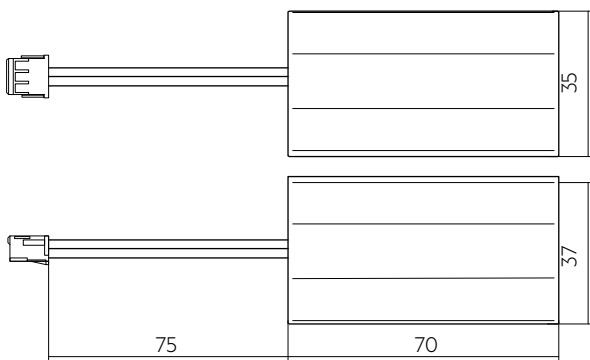

ACCU-LiFePO4 4.8Ah 3B CON R2A 68MM

Ordering data

Type	Article number	Capacity	Packaging, carton	Packaging, outer box	Weight per pc.
ACCU-LiFePO4 3.3Ah 1A CON R2A 68MM	28005688	3.3 Ah	20 pc(s).	80 pc(s).	0.232 kg

EM r2a Exit Sign 90°

Accessory



Product description

- _ Surface mount bracket in white (RAL 9016)
- _ For mounting at right angles to the wall
- _ Suitable for EM r2a Exit Sign 2

Website

<http://www.tridonic.com/28006314>



Ordering data

Type	Article number	Packaging, carton	Weight per pc.
EM R2A Exit Sign 2 90°	28006314	70 pc(s).	0.118 kg

EM r2a Exit Sign dia

Accessory



Product description

- _ Spare directional sign (diagonal left, right, up and down)
- _ Maximum viewing distance of 30 m
- _ One piece of ISO 7010 rotatable direction sign
- _ Suitable for EM r2a Exit Sign 2

Website

<http://www.tridonic.com/28006315>



Ordering data

Type	Article number	Packaging, carton	Weight per pc.
EM R2A Exit Sign 2 dia	28006315	30 pc(s).	0.24 kg

EM r2a Exit Sign Rec

Accessory



Product description

- _ Recessed mounting frame for EM r2a Exit Sign 2
- _ Two colour options white (RAL 9016) or black (RAL 9005)
- _ Suitable for EM r2a Exit Sign 2

Website

<http://www.tridonic.com/28006586>



Ordering data

Type	Article number	Packaging, carton	Weight per pc.
EM R2A Exit Sign 2 rec BK	28006586	1 pc(s).	0.31 kg
EM R2A Exit Sign 2 rec WH	28006312	1 pc(s).	0.27 kg

EM r2a Exit Sign sus

Accessory



Product description

- _ Cord suspension for EM r2a Exit Sign 2
- _ Height adjustment up to lengths of 2 m
- _ Suitable for EM r2a Exit Sign 2

Website

<http://www.tridonic.com/28006313>



Ordering data

Type	Article number	Packaging, carton	Weight per pc.
EM R2A Exit Sign 2 sus	28006313	150 pc(s).	0.112 kg

1. Standards

according to EN 50172
 EN 55015
 EN 60068-2-64
 EN 60068-2-27
 according to EN 60068-2-30
 EN 60598-1
 EN 60598-2-2
 EN 60598-2-22
 EN 61000-3-2
 EN 61000-3-3
 EN 61347-1
 EN 61347-2-7
 EN 61347-2-7/A1
 EN 61347-2-13
 EN 61347-2-13/A1
 EN 61547
 EN 62384
 EN 62386-101
 EN 62386-102
 EN 62386-202
 IEC 62620 (related to Lithium Iron battery)
 IEC 62133 (related to Lithium Iron battery)
 UN 38.3 (related to Lithium Iron battery)
 EN 62031
 EN 62034
 EN 62471
 ISO 3864-1
 ISO 3864-4
 ISO 7010

1.1 Glow-wire test

according to EN 60598-1 with increased temperature of 850 °C for the housing and 650 °C for the blades passed.

2. Thermal data

2.1 Temperature range

According to the standard IEC 60598-1 a LED driver for remote installation has a max. case temperature of 90 °C. The ambient temperature range t_a for the EM R2A PRO is defined to meet this requirement.

2.2 Expected lifetime

Average lifetime 100,000 hours under rated conditions with a failure rate of less than 10 %. Average failure rate of 0.2% per 1,000 operating hours.

Expected lifetime				
Type	t_a	30 °C	35 °C	40 °C
EM R2A PRO	lifetime	> 100,000 h	> 100,000 h	> 100,000 h

2.3 Storage conditions

- Humidity 5% up to max. 85 %, not condensed (max. 56 days/year at 85 %)

Note: The devices have to be within the specified temperature range (t_a) before they are operated.

- Store batteries within the specified temperature range in low humidity conditions. Optimal storage conditions are:
 - Temperature: -20 ... +35 °C for up to 15 months
 - Relative humidity: 65 % \pm 5 %
- Avoid atmosphere with corrosive gas
- Disconnect batteries before store or delivery
- Avoid storage of discharged batteries

3. Installation / Wiring

3.1 Luminaire assembly

- Wear gloves when mounting the EM ready2apply Exit Sign.
- Prepare adequate fixings: screws, plugs, supply cords, glands, tools, etc.
- Select mounting option:
 - Ceiling
 - Wall
 - Recessed
 - Flag
 - Suspended
- Identify the front side using the indication on the pictogram support part
- Select the direction of running man and arrow
 - Attention: follow the mounting instructions for correct positioning of the pictogram
- Insert the pictograms in the support part according to preferred direction
- The mounting holes on the back plate are prepared and can be drilled through with a screwdriver or a drill.
 - For ceiling, flag or suspended, drill at the top
 - For wall, drill at the back
 - For recessed, no drilling required
- Fix the back plate
 - For ceiling and wall mount, fix the back plate to the surface using drilled hold and adequate fixing (for wall mounting: ensure the screw does not touch the battery)
 - For recessed, insert the luminaire in the accessory
 - For suspended and flag mount, install the accessory to the mounting surface, and fix the back plate to the accessory
- Wire the mains terminal block
 - For flag and suspended, external supply cord is required.
 - For suspended, gland is required to strain relief the supply cord
- Plug the battery into the connector.
- Attach the pictogram to the electronics housing to complete the luminaire
 - Attention: the parts are polarity sensitive
- Insert the luminaire in the back plate



Take care when drilling to prevent damage to internal components.

3.2 Wiring diagrams

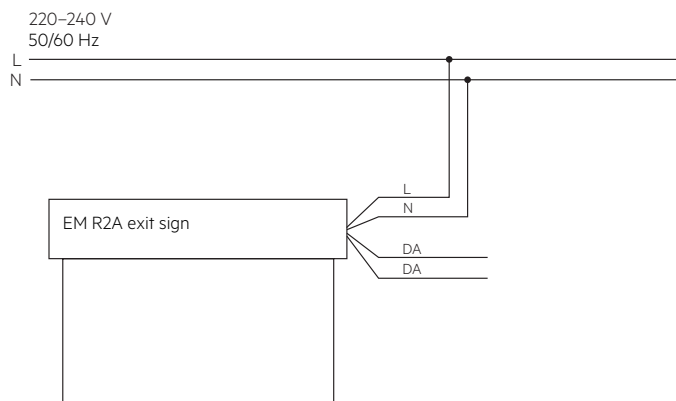

Note: Battery must be connected before mains connection.

3.3 Wiring type and cross-section

Wiring

Mains (N, L)
DALI (DA, DA)
Through wiring possible

Cable: low smoke, halogen free

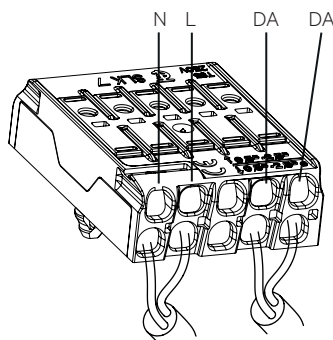

Installation of the luminaire only by a qualified person.

Use solid/stranded wire with a cross section of 0.5 – 2.5 mm² for wiring. Strip 9 – 10 mm of insulation from the cables to ensure perfect operation of terminals.

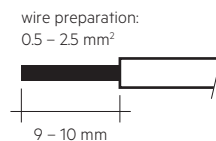

4. Mechanical data

4.1 Housing properties

- Polycarbonate white, similar to RAL 9016
- Polycarbonate black, similar to RAL 9005

4.2 Battery connection

Battery pack connection
3-pole plug connection

4.3 Fixing

Several mounting options possible:

- Ceiling
- Wall
- Recessed
- Flag
- Suspended

Fixing for recess mount:

- Cut-out: 365 x 55 mm
- Ceiling thickness: 1 – 25 mm
- Ceiling void height: min. 100 mm

Two easy breakable entry holes at rear and upper part for cable entry. Recommended screws: 3 to 4 mm diameter, avoid countersunk screws.



Device not suitable for covering with thermally insulating material

5. Electrical data

5.1 Maximum loading of automatic circuit breakers

Automatic circuit breaker type	B10	B13	B16	B20	C10	C13	C16	C20	Inrush current
Installation Ø	1.5 mm ²	1.5 mm ²	2.5 mm ²	2.5 mm ²	1.5 mm ²	1.5 mm ²	2.5 mm ²	2.5 mm ²	I _{max} time
EM R2A PRO	90	130	130	130	180	260	260	260	10 A 120 µs

5.2 Insulation matrix

	Mains	Battery, LED, Indicator LED
Mains	-	••
Battery, LED, Indicator LED	••	-

• Represents basic insulation

•• Represents double or reinforced insulation

5.3 Battery charge regime / discharge

EM R2A Exit Sign PRO 231 30m, 3 h

Type		EM R2A Exit Sign PRO 231 30m
Article no.		89801283, 89801287
Cells		1 cells
Duration		3 h
Battery charge time	Initial	20 h
	Trickle charge	continuously and battery voltage controlled
Typ. charge current ^①	Initial charge	270 mA
	Trickle charge ^①	270 mA / 0 mA
Charge voltage range ^②		2.0 – 3.6 V per cell
Discharge voltage range		2.3 – 3.6 V per cell

^① Automatic recharge when battery voltage falls below 3.4 V. Charger off (0 mA) when battery voltage exceeds 3.6 V.

Note: Battery protected against operation at excessive temperatures (charging stopped when battery cell temperature < 0 °C or > 60 °C)

^② The battery will not be charged below 2.0 V.

5.4 Battery selection for replacement

EM R2A Exit Sign PRO 231 30m, 3 h

Type		EM R2A Exit Sign PRO 231 30m			
Article no.		89801283, 89801287			
Cells		1 cells			
Duration		3 h			
Technology and capacity	Design	Number of cells	Type	Article no.	Assignable batteries
Lithium Iron Phosphate 3.3 Ah	stick	1	ACCU-LiFePO4 3.3Ah 1A CON R2A 68MM	28005688	•

Note: If the rated duration of operation cannot be reached the battery must be replaced. Remove mains during battery replacement.

6. Software / Programming / Interfaces

6.1 Software / programming

With appropriate software and interface different functions can be activated and various parameters can be configured in the LED driver. The Driver supports the following software and interfaces:

Software / hardware for configuration:

- companionSUITE (deviceGENERATOR, deviceCONFIGURATOR, deviceANALYSER)
- masterCONFIGURATOR

Interfaces for data transfer:

- Control input DALI

6.2 Control input DALI

The control input is non-polar for digital control signals (DALI). The control signal is not SELV. The control cable has to be installed in accordance to the requirements of low voltage installations.

Digital control with:

- DALI signal: 16 bit

7. Functions

⊙ companionSUITE:

DALI-USB

The companionSUITE with deviceGENERATOR, deviceCONFIGURATOR and deviceANALYSER is available via our WEB page: <https://companionsuite.tridonic.com/#/devicegenerator>

◇ masterCONFIGURATOR:

DALI-USB

The masterCONFIGURATOR is available via our WEB page: <https://www.tridonic.com/com/en/software-masterconfigurator.asp>

Icon	Function	DALI-2
	OEM Identification	⊙ ◇
	OEM GTIN	⊙ ◇
	Label information	⊙ ◇
	Factory reset	⊙ ◇
	Device operating mode	⊙ ◇
	Prolong time	⊙ ◇
	Autotest	⊙ ◇
	Test window	⊙ ◇
	Addressing	⊙ ◇
	DALI default parameters	⊙ ◇
	Scenes and group	⊙ ◇

7.1 OEM Identification



The OEM (Original Equipment Manufacturer) can set his own identification number.

7.2 OEM GTIN



The Original Equipment Manufacturer (OEM) can set his own Global Trade Item Number (GTIN).

7.3 Label information



In production, an individual label can be printed out for each device. For this there are different default values (Batch No., Production Date, ...) available. In addition, you can use these two text input fields to insert your own luminaire information and print it out.

- Article number (48 characters)
- Description (6 x 48 characters)



This information is not stored on the device, it is only used for the label print function in the deviceCONFIGURATOR.

7.4 Prolong time



Prolong time can be set by the DALI controller. Here you can set how long the emergency operation will be maintained after power recovery. The module exits the PROLONG mode as soon as the cut-off threshold of the battery voltage has been reached (total discharge protection), that is when the total operating time has been exceeded. The default prolong time is set as 0 minutes as specified within the DALI standard. Indicator LED will stay off for the duration of the prolong time.

7.5 Autotest



7.5.1 Functional test

The time of day and frequency of the 5 seconds function test can be set by the DALI controller. The default setting is a 5 seconds test on a weekly basis.

7.5.2 Duration test

The time of day and frequency of the duration test can be set by the DALI controller. The default setting is a duration test conducted every 52 weeks.

For 2 h operation:

The first commissioning duration test has a time of 120 minutes, subsequent through life tests are conducted for 90 minutes. When the battery is changed or disconnected and re-connected the unit will next conduct a 120 minute test.

7.6 Test window



The test window sets the maximum time between the scheduled start time or test request via DALI and the actual execution of the test. If the test cannot be executed in the test window, the TEST EXECUTION TIMEOUT bit in the FAILURE STATUS is set.

7.7 DALI default parameters



In order for all luminaires to react the same for each operation (switching, dimming, scene recall ...), these values must be set the same. These DALI standard parameters are supported by every DALI-2 device.

7.8 Scenes and groups



Each device can be a member of up to 16 groups. Also, 16 different scene values can be stored in each device.

7.9 Status indication

System status is indicated by a bi-colour LED and by a DALI status flag. The indication LED is integrated on the bottom left of the housing.

LED indication	Status	Comment
Permanent green	System OK	AC mode
Fast flashing green (0,1 sec on – 0,1 sec off)	Function test underway	
Slow flashing green (1 sec on – 1 sec off)	Duration test underway	
Red LED on	Load failure	Open circuit / Short circuit / LED failure
Slow flashing red (1 sec on – 1 sec off)	Battery failure	Battery failed the duration test or function test / Battery is defect or deep discharged / Incorrect battery voltage / Battery is outside of its temperature range for charging (0 – 60 °C)
Fast flashing red (0,1 sec on – 0,1 sec off)	Charging failure	Incorrect charging current
Double pulsing green	DALI Inhibit	Switching into DALI inhibit mode via controller
Binary transmission of address via green/red LED	Address identification	During address identification mode
Green and red off	DC mode	Battery operation (emergency mode)

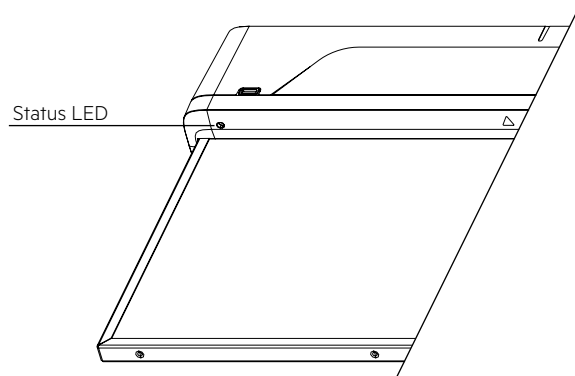

7.10 Maintained / non-maintained

Can be select via jumper.
Jumper on: maintained
Jumper off: non-maintained

Battery and mains must be disconnected in order to change maintained / non-maintained.

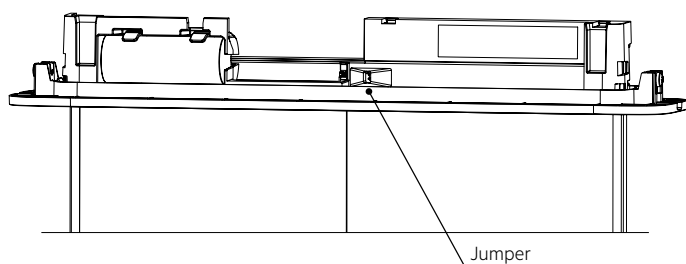

7.11 Testing

DALI Control

A DALI command from a suitable control unit can be used to initiate function and duration tests at individually selected times. Status flags are set for report back and data logging of results.

When a DALI bus has not been connected or when a DALI bus is connected but the DALI default DELAY and INTERVAL times have not been re-set by sending appropriate DALI commands, then the EM R2A will conduct self-tests in accordance with the default times set within the EEPROM . These default times are factory pre-set, in accordance with the DALI standard EN 62386-202, to conduct an automatic function test every 7 days and a duration test every 52 weeks. Since the DELAY time is factory pre-set to Zero, all units are tested at the same time. Test times can be changed with a command over the DALI bus.

The DELAY and INTERVAL time values must be re-set when the emergency system test times are to be scheduled by a DALI control and monitoring system.

Note that once the default values have been set to Zero, tests will only be conducted following a command from the control system. If the DALI bus is disconnected the EM R2A does not revert to self-testing mode.

Note: If the battery is connected the DALI communication is only possible after power reset.

Addressing

The EM R2A includes the EZ easy addressing system which allows addressing and identification by using the bi-colour LED. Binary address codes given by the LED can be simply converted to the DALI addresses 0 to 63. For single handed addressing using this method it is necessary to send a broadcast ident command every 3 to 9 seconds. During this command the LEDs will be switched off and the indication LED will flash the 6 bit binary address preceded by a 3 second start indication period.

Commissioning

After installation of the luminaire and initial connection of the mains supply and battery supply to the EM R2A the unit will commence charging the batteries for 20 hours (initial charge). Afterwards the module will conduct a commissioning test for the full duration. The 20 hours recharge occurs also if a new battery is connected or the module exits the rest mode condition. The following automatic commissioning duration test is only performed when a battery is replaced and fully charged (after 20 hrs) and the interval time is not set to zero, otherwise the system is expected to perform the testing.

Timer reset functionality

The timer for function and duration test can be set to a particular time of the day by cycling the unswitched line supply 5 times within 1 minute. The timer adjustment will enable the test start time to be defined manually at time in day when the timer was reset. It will also disable the adaptive test algorithm thereby forcing the unit to perform the test at the same time rather than it being defined by the adaptive algorithm. This function will only work provided the interval time is greater than zero (automatic test mode enabled). The delay timer value set when the unit was commissioned will be reloaded in order to randomise the tests between adjacent units.

Prolong time

Prolong time can be set by the DALI controller. Here you can set how long the emergency operation will be maintained after power recovery.

The module exits the PROLONG mode as soon as the cut-off threshold of the battery voltage has been reached (total discharge protection), that is when the total operating time has been exceeded.

The default prolong time is set as 0 minutes as specified within the DALI standard.

Indicator LED will stay off for the duration of the prolong time.

Rest Mode / Inhibit Mode

Emergency operation is automatically started when the mains supply is switched off. If the Rest Mode is activated, the discharging of the battery will be minimized by switching off the LED output. If the Inhibit Mode has been activated before the mains supply is switched off, Rest Mode will be automatically switched on if the mains supply is switched off within 15 minutes.

Rest Mode and Inhibit Mode can be initiated by the DALI controller. The REST command has to be sent after the mains supply has been disconnected and whilst the EM r2a PRO Exit is in emergency operation. The INHIBIT command has to be sent while the EM r2a PRO Exit is supplied by mains.

After a mains reset the EM r2a PRO Exit exits the Rest Mode. Rest Mode and Inhibit Mode can both be disabled by sending the RE-LIGHT/RESET INHIBIT command.

In combination with a 1-cell battery the EM r2a PRO Exit does not support Rest Mode / Inhibit Mode.

Max. rest mode duration: 21 days from fully charged battery

DALI Controller

DALI controllers and hardware/software solutions are available from Tridonic. Please refer to the Lighting controls section.

Functional test

The time of day and frequency of the 5 seconds function test can be set by the DALI controller. The default setting is a 5 seconds test on a weekly basis.

Duration test

The time of day and frequency of the duration test can be set by the DALI controller. The default setting is a duration test conducted every 52 weeks.

7.12 Safety**7.12.1 Deep discharge protection**

When the battery remains connected without charging for a long period of time after the battery cut off of the driver the battery voltage can still drop. To make sure the cells are not damaged by this voltage drop, the battery protection prevents the battery from further discharge below 2.0 V.

7.12.2 Overcharge protection

If in case of an error or the use of a wrong driver the battery gets overcharged the battery protection will disconnect the battery from the driver at a voltage of 3.9 V. A discharge of the battery is still possible after the protection circuit was triggered to guarantee emergency operation.

7.12.3 Short-circuit protection

In case of a short circuit the battery protection opens the connection to the driver and the output is therefore free of voltage. The output will be reactivated again when the short circuit is removed.

7.12.4 Temperature protection

The battery is protected against temporary thermal overheating. If the temperature limit is exceeded the further charging of the battery is no longer possible. The temperature protection is activated below approx. 0 °C and above approx. +60 °C. The discharging of the battery is still possible to guarantee emergency operation.

7.13 Technical data batteries**Accu Lithium Iron Phosphate****Capacity 3.3 Ah**

International designation	IFpR 27/67
Battery voltage/cell	3.2 V
Cell type	26650
Single cell dimensions	
Diameter	26 mm
Height	65 mm
Max. short term temperature (reduced lifetime)	70 °C
Max. number discharge cycles	50 cycles total
Max. storage time	15 months
	at -20 to +35 °C
Packing quantity	1 pc. per carton

Only use Tridonic batteries.

Comply with UN 38.3, IEC 62620 and IEC 62133 (safety testing) protected against over charge, over discharge, charging at excessive temperatures, short-circuit and over current.

For battery data see separate data sheet.

8. Miscellaneous**8.1 Battery replacement**

After a battery replacement and a subsequent full charge cycle (20 h) a duration test is mandatory to prove that with the new battery the rated duration is achieved.



Do not damage battery and other components during battery replacement.

8.2 Black Box data recording

Recording of several parameters only accessible for Tridonic.

8.3 Additional information

Additional technical information at www.tridonic.com → Technical Data

The light source of this luminaire is not replaceable; when the light source reaches its end of life replace the whole luminaire. Lifetime declarations are informative and represent no warranty claim. No warranty if device was opened.