

**EM R2A Exit Sign BASIC 231 30m**

EM ready2apply



**Product description**

- \_ LED emergency exit sign suitable for various mounting options (ceiling, wall, flag, recessed, suspended)
- \_ Independent and configurable pictogram
- \_ Pictogram 'running man' and straight arrow included in delivery
- \_ Diagonal arrow available as accessory
- \_ Arrows are rotatable, so all directions can be achieved with default product + 1 accessory
- \_ Emergency lighting function for manual testing
- \_ EM = Emergency

**Properties**

- \_ Viewing distance up to 30 m, double sided
- \_ Non-maintained and maintained operation
- \_ Very low stand-by power loss
- \_ 3 h rated duration
- \_ Breakable entrance holes at the back and top for 1 or 2 cables
- \_ Simple connection of Lithium Iron Phosphate battery with plug-in system
- \_ Integrated status LED
- \_ 5 years guarantee electronic (LED driver) (conditions at <https://www.tridonic.com/en/int/services/mfr-guarantee-conditions>)
- \_ 5 years guarantee for LiFePO4 batteries (conditions at <https://www.tridonic.com/en/int/services/mfr-guarantee-conditions>)

**Website**

<http://www.tridonic.com/89801281>



**EM R2A Exit Sign BASIC 231 30m**

EM ready2apply

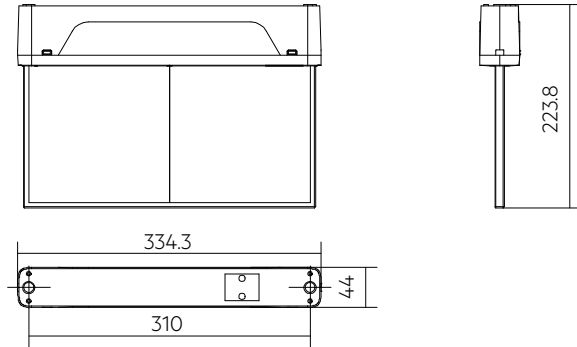

**Ordering data**

Type	Article number	Colour	Rated duration	Number of cells	Packaging, carton	Packaging, pallet	Weight per pc.
EM R2A Exit Sign BASIC 231 30m	89801281	White	3 h	1	1 pc(s).	100 pc(s).	1.155 kg
EM R2A Exit Sign BASIC 231 30m-B	89801285	Black	3 h	1	1 pc(s).	100 pc(s).	1.155 kg

**Technical data**

Rated supply voltage	220 – 240 V
Input voltage range AC (tolerance for safety)	198 – 264 V
Input voltage range AC (tolerance for performance)	198 – 254 V
Mains frequency	50 / 60 Hz
Overvoltage protection	320 V (for 48 h)
Starting time (Emergency operation)	< 0.5 s from detection of emergency event
Output current tolerance	± 10 %
LF current ripple	± 5 %
Ambient temperature range	+5 ... +40 °C
Mains voltage changeover threshold	According to EN 60598-2-22
Type of protection	IP40
Impact protection degree	IK03
Protection class	II
Lifetime	> 100,000 h

**Approval marks**



**Standards**

according to EN 50172, EN 55015, EN 60068-2-64, EN 60068-2-27, EN 60068-2-30, EN 60598-1, EN 60598-2-2, EN 60598-2-22, EN 61000-3-2, EN 61000-3-3, EN 61347-1, EN 61347-2-7, EN 61347-2-13, EN 61547, EN 62384, IEC 62620 (related to Lithium Iron battery), IEC 62133 (related to Lithium Iron battery), UN 38.3 (related to Lithium Iron battery), EN 62031, EN 62471, ISO 3864-1, ISO 3864-4, ISO 7010

**Specific technical data**

Type <sup>①</sup>	Rated duration	Number of LEDs	Typ. $\lambda$ Cat 230 V, 50 Hz)	Non-maintained operation		Maintained operation	
				Mains current in charging operation <sup>②</sup>	Mains power in charging operation <sup>②</sup>	Mains current in charging operation <sup>②</sup>	Mains power in charging operation <sup>②</sup>
EM R2A Exit Sign BASIC 231 30m	3 h	24	0.58C	19 / 11 mA	2.1 / 0.6 W	35 / 23 mA	4.6 / 2.6 W
EM R2A Exit Sign BASIC 231 30m-B	3 h	24	0.58C	19 / 11 mA	2.1 / 0.6 W	35 / 23 mA	4.6 / 2.6 W

① EM = Emergency

② For LiFePO4 batteries voltage dependent constant current charging is used. The values displayed are for charging on / charging off.

LiFePO4 Battery pack 3.3 – 4.8 Ah

Accessory



ACCU-LiFePO4 4.8Ah 3B CON R2A 68MM

**Product description**

- \_ High-temperature LiFePO4 cells only for use with Tridonic emergency lighting units
- \_ 6 year design life (up to 30 °C ambient temperature)
- \_ 4 year design life (up to 40 °C ambient temperature)
- \_ 5 years guarantee (conditions at <https://www.tridonic.com/en/int/services/manufacturer-guarantee-conditions>)

**Properties**

- \_ Certified quality manufacturer
- \_ Charge efficiency > 90 %
- \_ Low self discharge
- \_ Simple connection with plug-in system
- \_ Protection and monitoring circuit built into battery enclosure
- \_ Deep discharge protection
- \_ Suitable for emergency lighting equipment as per IEC 60598-2-22

**Website**

<http://www.tridonic.com/28005688>

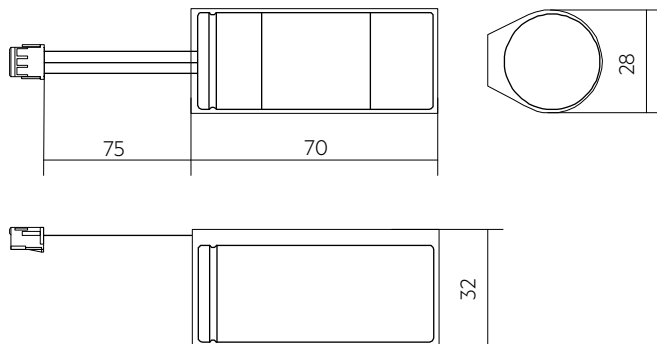

ACCU-LiFePO4 3.3Ah 1A CON R2A 68MM

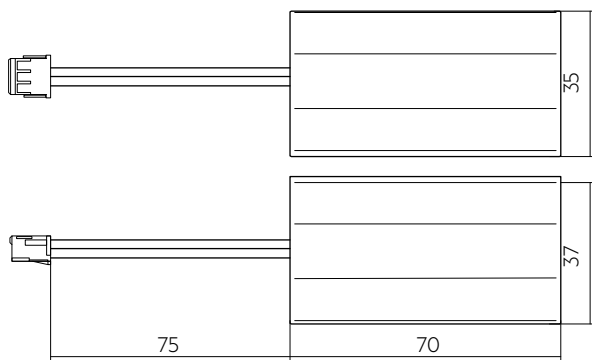

ACCU-LiFePO4 4.8Ah 3B CON R2A 68MM

**Ordering data**

Type	Article number	Capacity	Packaging, carton	Packaging, outer box	Weight per pc.
ACCU-LiFePO4 3.3Ah 1A CON R2A 68MM	28005688	3.3 Ah	20 pc(s).	80 pc(s).	0.232 kg

EM r2a Exit Sign 90°

Accessory



**Product description**

- \_ Surface mount bracket in white (RAL 9016)
- \_ For mounting at right angles to the wall
- \_ Suitable for EM r2a Exit Sign 2

**Website**

<http://www.tridonic.com/28006314>



**Ordering data**

Type	Article number	Packaging, carton	Weight per pc.
EM R2A Exit Sign 2 90°	28006314	70 pc(s).	0.118 kg

EM r2a Exit Sign dia

Accessory



**Product description**

- \_ Spare directional sign (diagonal left, right, up and down)
- \_ Maximum viewing distance of 30 m
- \_ One piece of ISO 7010 rotatable direction sign
- \_ Suitable for EM r2a Exit Sign 2

**Website**

<http://www.tridonic.com/28006315>



**Ordering data**

Type	Article number	Packaging, carton	Weight per pc.
EM R2A Exit Sign 2 dia	28006315	30 pc(s).	0.24 kg

EM r2a Exit Sign Rec

Accessory



**Product description**

- \_ Recessed mounting frame for EM r2a Exit Sign 2
- \_ Two colour options white (RAL 9016) or black (RAL 9005)
- \_ Suitable for EM r2a Exit Sign 2

**Website**

<http://www.tridonic.com/28006586>



**Ordering data**

Type	Article number	Packaging, carton	Weight per pc.
EM R2A Exit Sign 2 rec BK	28006586	1 pc(s).	0.31 kg
EM R2A Exit Sign 2 rec WH	28006312	1 pc(s).	0.27 kg

EM r2a Exit Sign sus

Accessory



**Product description**

- \_ Cord suspension for EM r2a Exit Sign 2
- \_ Height adjustment up to lengths of 2 m
- \_ Suitable for EM r2a Exit Sign 2

**Website**

<http://www.tridonic.com/28006313>



**Ordering data**

Type	Article number	Packaging, carton	Weight per pc.
EM R2A Exit Sign 2 sus	28006313	150 pc(s).	0.112 kg

## 1. Standards

according to EN 50172

EN 55015

EN 60068-2-64

EN 60068-2-27

according to EN 60068-2-30

EN 60598-1

EN 60598-2-2

EN 60598-2-22

EN 61000-3-2

EN 61000-3-3

EN 61347-1

EN 61347-2-7

EN 61347-2-7/A1

EN 61347-2-13

EN 61347-2-13/A1

EN 61547

EN 62384

IEC 62620 (related to Lithium Iron battery)

IEC 62133 (related to Lithium Iron battery)

UN 38.3 (related to Lithium Iron battery)

EN 62031

EN 62471

ISO 3864-1

ISO 3864-4

ISO 7010

### 1.1 Glow-wire test

according to EN 60598-1 with increased temperature of 850 °C for the housing and 650 °C for the blades passed.

## 2. Thermal data

### 2.1 Temperature range

According to the standard IEC 60598-1 a LED driver for remote installation has a max. case temperature of 90 °C. The ambient temperature range  $t_a$  for the EM R2A BASIC is defined to meet this requirement.

### 2.2 Expected lifetime

Average lifetime 100,000 hours under rated conditions with a failure rate of less than 10 %. Average failure rate of 0.2 % per 1,000 operating hours.

#### Expected lifetime

Type	$t_a$	30 °C	35 °C	40 °C
EM R2A BASIC	lifetime	> 100,000 h	> 100,000 h	> 100,000 h

### 2.3 Storage conditions

- Humidity 5 % up to max. 85 %, not condensed (max. 56 days/year at 85 %)

Note: The devices have to be within the specified temperature range ( $t_a$ ) before they are operated.

- Store batteries within the specified temperature range in low humidity conditions. Optimal storage conditions are:
  - Temperature: -20... +35 °C for up to 15 months
  - Relative humidity: 65 %  $\pm$  5 %
- Avoid atmosphere with corrosive gas
- Disconnect batteries before store or delivery
- Avoid storage of discharged batteries

## 3. Installation / Wiring

### 3.1 Luminaire assembly

- Wear gloves when mounting the EM ready2apply Exit Sign.
- Prepare adequate fixings: screws, plugs, supply cords, glands, tools, etc.
- Select mounting option:
  - Ceiling
  - Wall
  - Recessed
  - Flag
  - Suspended
- Identify the front side using the indication on the pictogram support part
- Select the direction of running man and arrow
  - Attention: follow the mounting instructions for correct positioning of the pictogram
- Insert the pictograms in the support part according to preferred direction
- The mounting holes on the back plate are prepared and can be drilled through with a screwdriver or a drill.
  - For ceiling, flag or suspended, drill at the top
  - For wall, drill at the back
  - For recessed, no drilling required
- Fix the back plate
  - For ceiling and wall mount, fix the back plate to the surface using drilled hold and adequate fixing (for wall mounting: ensure the screw does not touch the battery)
  - For recessed, insert the luminaire in the accessory
  - For suspended and flag mount, install the accessory to the mounting surface, and fix the back plate to the accessory
- Wire the mains terminal block
  - For flag and suspended, external supply cord is required.
  - For suspended, gland is required to strain relief the supply cord
- Plug the battery into the connector.
- Attach the pictogram to the electronics housing to complete the luminaire
  - Attention: the parts are polarity sensitive
- Insert the luminaire in the back plate



Take care when drilling to prevent damage to internal components.

### 3.2 Wiring diagrams

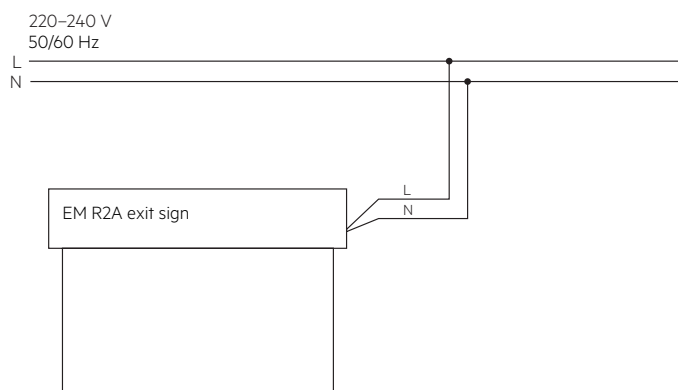

Note: Battery must be connected before mains connection.

### 3.3 Wiring type and cross-section

#### Wiring

Mains (N, L)

Through wiring possible

Cable: low smoke, halogen free

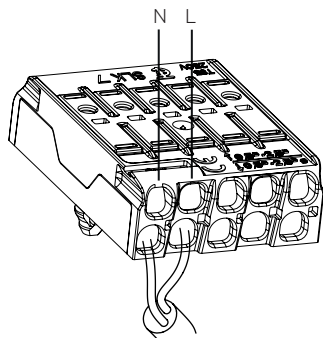

Installation of the luminaire only by a qualified person.

Use solid/stranded wire with a cross section of 0.5 – 2.5 mm<sup>2</sup> for wiring.  
Strip 9 – 10 mm of insulation from the cables to ensure perfect operation of terminals.

wire preparation:  
0.5 – 2.5 mm<sup>2</sup>

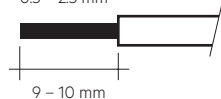

### 4. Mechanical data

#### 4.1 Housing properties

- Polycarbonate white, similar to RAL 9016
- Polycarbonate black, similar to RAL 9005

#### 4.2 Battery connection

Battery pack connection  
3-pole plug connection

#### 4.3 Fixing

Several mounting options possible:

- Ceiling
- Wall
- Recessed
- Flag
- Suspended

Fixing for recess mount:

- Cut-out: 365 x 55 mm
- Ceiling thickness: 1 – 25 mm
- Ceiling void height: min. 100 mm

Two easy breakable entry holes at rear and upper part for cable entry.  
Recommended screws: 3 to 4 mm diameter, avoid countersunk screws.



Device not suitable for covering with thermally insulating material

## 5. Electrical data

### 5.1 Maximum loading of automatic circuit breakers

Automatic circuit breaker type	B10	B13	B16	B20	C10	C13	C16	C20	Inrush current
Installation Ø	1.5 mm <sup>2</sup>	1.5 mm <sup>2</sup>	2.5 mm <sup>2</sup>	2.5 mm <sup>2</sup>	1.5 mm <sup>2</sup>	1.5 mm <sup>2</sup>	2.5 mm <sup>2</sup>	2.5 mm <sup>2</sup>	I <sub>max</sub> time
<b>EM R2A BASIC</b>	90	130	130	130	180	260	260	260	10 A 120 µs

### 5.2 Insulation matrix

	Mains	Battery, LED, Indicator LED
Mains	-	••
Battery, LED, Indicator LED	••	-

• Represents basic insulation

•• Represents double or reinforced insulation

### 5.3 Battery charge regime / discharge

#### EM R2A Exit Sign BASIC 231 30m, 3 h

	<b>Type</b>	<b>EM R2A Exit Sign BASIC 231 30m</b>
	<b>Article no.</b>	<b>89801281, 89801285</b>
	<b>Cells</b>	<b>1 cells</b>
	<b>Duration</b>	<b>3 h</b>
Battery charge time	Initial	20 h
	Trickle charge	continuously and battery voltage controlled
Typ. charge current <sup>①</sup>	Initial charge	270 mA
	Trickle charge <sup>①</sup>	270 mA / 0 mA
Charge voltage range <sup>②</sup>		2.0 – 3.6 V per cell
Discharge voltage range		2.3 – 3.6 V per cell

<sup>①</sup> Automatic recharge when battery voltage falls below 3.4 V. Charger off (0 mA) when battery voltage exceeds 3.6 V.

Note: Battery protected against operation at excessive temperatures (charging stopped when battery cell temperature < 0 °C or > 60 °C)

<sup>②</sup> The battery will not be charged below 2.0 V.

### 5.4 Battery selection for replacement

#### EM R2A Exit Sign BASIC 231 30m, 3 h

	<b>Type</b>	<b>EM R2A Exit Sign BASIC 231 30m</b>			
	<b>Article no.</b>	<b>89801281, 89801285</b>			
	<b>Cells</b>	<b>1 cells</b>			
	<b>Duration</b>	<b>3 h</b>			
Technology and capacity	Design	Number of cells	<b>Type</b>	<b>Article no.</b>	<b>Assignable batteries</b>
Lithium Iron Phosphate 3.3 Ah	stick	1	<b>ACCU-LiFePO4 3.3Ah 1A CON R2A 68MM</b>	<b>28005688</b>	<b>•</b>

Note: If the rated duration of operation cannot be reached the battery must be replaced. Remove mains during battery replacement.

## 6. Functions

### 6.1 Status indication

The indication LED is integrated on the bottom left of the housing. A green LED indicates that charging current is flowing into the battery. The battery is protected against operation at excessive temperatures (charging stops and indication LED turns off when battery cell temperature  $< 0\text{ °C}$  or  $> 60\text{ °C}$ ).

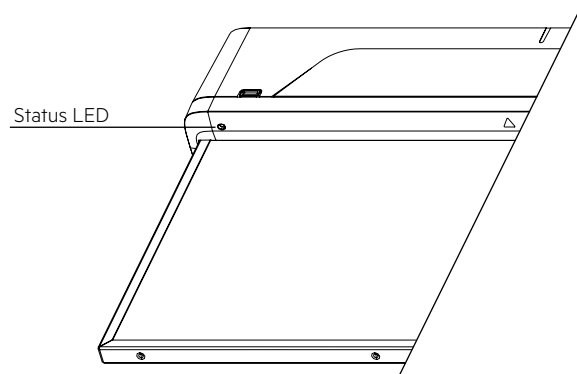

### 6.2 Maintained / non-maintained

Can be select via jumper.  
Jumper on: maintained  
Jumper off: non-maintained

Battery and mains must be disconnected in order to change maintained / non-maintained.

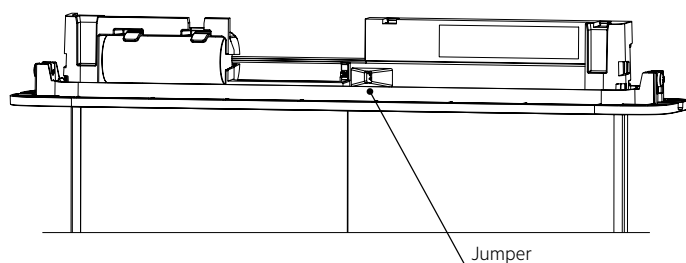

### 6.3 Testing

Emergency operation can be manually tested by removal of the mains supply.

### 6.4 Safety

#### 6.4.1 Deep discharge protection

When the battery remains connected without charging for a long period of time after the battery cut off of the driver the battery voltage can still drop. To make sure the cells are not damaged by this voltage drop, the battery protection prevents the battery from further discharge below 2.0 V.

#### 6.4.2 Overcharge protection

If in case of an error or the use of a wrong driver the battery gets overcharged the battery protection will disconnect the battery from the driver at a voltage of 3.9 V. A discharge of the battery is still possible after the protection circuit was triggered to guarantee emergency operation.

#### 6.4.3 Short-circuit protection

In case of a short circuit the battery protection opens the connection to the driver and the output is therefore free of voltage. The output will be reactivated again when the short circuit is removed.

#### 6.4.4 Temperature protection

The battery is protected against temporary thermal overheating. If the temperature limit is exceeded the further charging of the battery is no longer possible. The temperature protection is activated below approx.  $0\text{ °C}$  and above approx.  $+60\text{ °C}$ . The discharging of the battery is still possible to guarantee emergency operation.

### 6.5 Technical data batteries

#### Accu Lithium Iron Phosphate

##### Capacity 3.3 Ah

International designation	IFpR 27/67
Battery voltage/cell	3.2 V
Cell type	26650
Single cell dimensions	
Diameter	26 mm
Height	65 mm
Max. short term temperature (reduced lifetime)	70 °C
Max. number discharge cycles	50 cycles total
Max. storage time	15 months
	at $-20$ to $+35\text{ °C}$
Packing quantity	1 pc. per carton

Only use Tridonic batteries.

Comply with UN 38.3, IEC 62620 and IEC 62133 (safety testing) protected against over charge, over discharge, charging at excessive temperatures, short-circuit and over current.

For battery data see separate data sheet.

## 7. Miscellaneous

### 7.1 Battery replacement

After a battery replacement and a subsequent full charge cycle (20 h) a duration test is mandatory to prove that with the new battery the rated duration is achieved.



Do not damage battery and other components during battery replacement.

### 7.2 Black Box data recording

Recording of several parameters only accessible for Tridonic.

### 7.3 Additional information

Additional technical information at [www.tridonic.com](http://www.tridonic.com) → Technical Data

The light source of this luminaire is not replaceable; when the light source reaches its end of life replace the whole luminaire. Lifetime declarations are informative and represent no warranty claim. No warranty if device was opened.