

ELA TW ADV2 M3

Modules ELA advanced

**Product description**

- _ Tunable White LED module with 2,700 and 6,500 K SMT package
- _ Edgelit panel for direct recessed mount and surface or suspended mount with accessories
- _ With pre-installed connection cable and integrated plug
- _ For suspended ceiling grid measure of 600 mm
- _ IK rating IK02
- _ Product colour (frame) RAL 9003
- _ Diffusor material: PS
- _ Lightguide material: PMMA
- _ HE ... High Efficiency, NM ... Nominal Mode, HO ... High Output
- _ Orders only in full carton quantities.
- _ Long lifetime: 50,000 hours
- _ 5 years guarantee (conditions at <https://www.tridonic.com/en/int/services/manufacturer-guarantee-conditions>)

Optical properties

- _ Useful luminous flux 3,850 lm at Irated and tp = 25 °C
- _ Efficacy of the LED module 123 lm/W at Irated and tp = 25 °C
- _ High colour rendering index CRI > 80
- _ Small colour tolerance (MacAdam 3) ^①
- _ Small luminous flux tolerances
- _ UGR < 19

Mechanical properties

- _ Module dimension 595 x 595 mm

System solution

- _ Combine Tridonic's LED modules and dimmable drivers to achieve an outstanding system efficacy (configuration possible via <https://setbuilder.tridonic.com/>)

^① Integral measurement over the complete module.

Website

<http://www.tridonic.com/28005396>

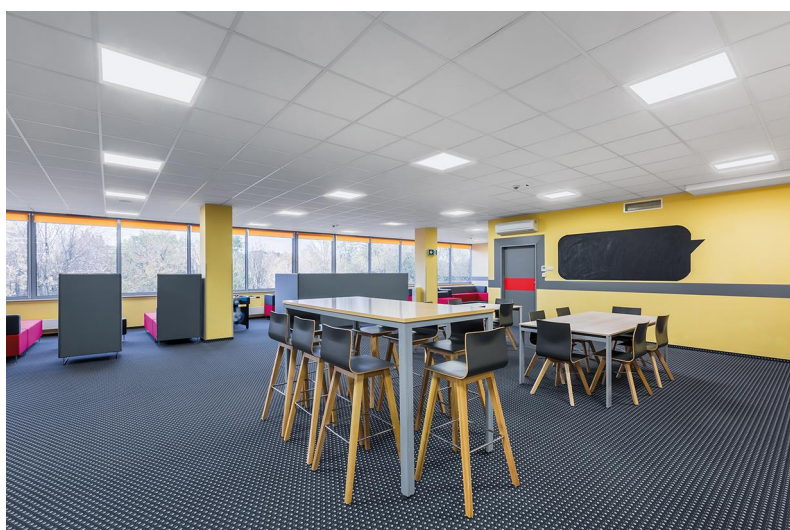

Linear



High bay



Decorative



Downlights



Spotlights



Free-standing



Area



Floor | Wall



Street

ELA TW ADV2 M3

Modules ELA advanced

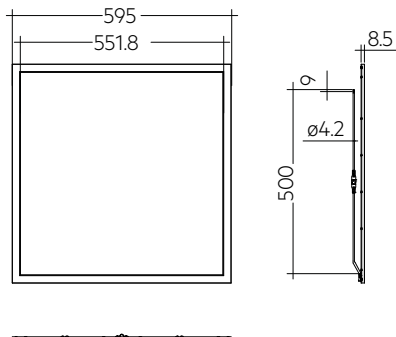

Ordering data

Type	Article number	Colour temperature	Packaging, carton	Weight per pc.
ELA 600x600mm 3800lm 827-865 ADV2 M3	28005396	2,700 – 6,500 K	5 pc(s).	2.50 kg
ELA 600x600mm 3800lm 827-865 ADV2 TPA M3	28006665	2,700 – 6,500 K	5 pc(s).	2.65 kg

Technical data

Beam characteristic	90°
Ambient temperature t_a	-20 ... +40 °C
t_p rated	45 °C
t_c	70 °C
I_{rated}	900 mA
I_{max}	1,050 mA
Max. permissible LF current ripple	1,365 mA
Max. permissible peak current	1,500 mA / max. 10 ms
Max. working voltage for insulation SELV	< 60 V
Insulation test voltage	0.5 kV
Colour tolerance ^①	3 SDCM
ESD classification	Severity level 2
Risk group (IEC 62471) ^②	RG0
Classification acc. to IEC 62031	Independent
Type of protection	IP40 (front) / IP20 (back)
Lumen maintenance L70B50	50,000 h
Guarantee (conditions at www.tridonic.com)	5 Year(s)

Approval marks



Standards

EN 62031, EN 62471, EN 61000-4-2, EN 62717, EN 60598-1

Specific technical data

Type	Article number	Colour temperature	Photometric code	Useful luminous flux at tp = 25 °C ^①	Expected luminous flux at tp rated ^②	Type forward current	Min. forward voltage at tp rated	Max. forward voltage at tp = 25 °C	Power consumption ^③ Pon at tp = 25 °C	Efficacy of the module at tp = 25 °C	Expected efficacy of the module at tp rated	Colour rendering index CRI
Operating mode HE at 700 mA												
ELA 600x600mm 3800lm 827-865 ADV2 M3	28005396	2,700 K	827/359	-	2,850 lm	700 mA	32.1 V	35.9 V	-	-	120 lm/W	>80
ELA 600x600mm 3800lm 827-865 ADV2 M3	28005396	3,000 K	830/359	-	2,985 lm	700 mA	32.1 V	35.9 V	-	-	126 lm/W	>80
ELA 600x600mm 3800lm 827-865 ADV2 M3	28005396	4,000 K	840/359	-	3,165 lm	700 mA	30.5 V	34.1 V	-	-	141 lm/W	>80
ELA 600x600mm 3800lm 827-865 ADV2 M3	28005396	6,500 K	865/359	-	3,165 lm	700 mA	32.1 V	35.9 V	-	-	134 lm/W	>80
ELA 600x600mm 3800lm 827-865 ADV2 TPA M3	28006665	2,700 K	827/359	-	2,850 lm	700 mA	32.1 V	35.9 V	-	-	120 lm/W	>80
ELA 600x600mm 3800lm 827-865 ADV2 TPA M3	28006665	3,000 K	830/359	-	2,985 lm	700 mA	32.1 V	35.9 V	-	-	126 lm/W	>80
ELA 600x600mm 3800lm 827-865 ADV2 TPA M3	28006665	4,000 K	840/359	-	3,165 lm	700 mA	30.5 V	34.1 V	-	-	141 lm/W	>80
ELA 600x600mm 3800lm 827-865 ADV2 TPA M3	28006665	6,500 K	865/359	-	3,165 lm	700 mA	32.1 V	35.9 V	-	-	134 lm/W	>80
Operating mode NM at 900 mA												
ELA 600x600mm 3800lm 827-865 ADV2 M3	28005396	2,700 K	827/359	3,850 lm	3,590 lm	900 mA	32.9 V	36.6 V	31.4 W	123 lm/W	116 lm/W	>80
ELA 600x600mm 3800lm 827-865 ADV2 M3	28005396	3,000 K	830/359	-	3,705 lm	900 mA	32.9 V	36.6 V	-	-	119 lm/W	>80
ELA 600x600mm 3800lm 827-865 ADV2 M3	28005396	4,000 K	840/359	-	3,995 lm	900 mA	31.2 V	34.8 V	-	-	135 lm/W	>80
ELA 600x600mm 3800lm 827-865 ADV2 M3	28005396	6,500 K	865/359	-	3,995 lm	900 mA	32.9 V	36.6 V	-	-	126 lm/W	>80
ELA 600x600mm 3800lm 827-865 ADV2 TPA M3	28006665	2,700 K	827/359	3,390 lm	3,590 lm	900 mA	32.9 V	36.6 V	31.4 W	108 lm/W	116 lm/W	>80
ELA 600x600mm 3800lm 827-865 ADV2 TPA M3	28006665	3,000 K	830/359	-	3,705 lm	900 mA	32.9 V	36.6 V	-	-	119 lm/W	>80
ELA 600x600mm 3800lm 827-865 ADV2 TPA M3	28006665	4,000 K	840/359	-	3,995 lm	900 mA	31.2 V	34.8 V	-	-	135 lm/W	>80
ELA 600x600mm 3800lm 827-865 ADV2 TPA M3	28006665	6,500 K	865/359	-	3,995 lm	900 mA	32.9 V	36.6 V	-	-	126 lm/W	>80
Operating mode HO at 1,050 mA												
ELA 600x600mm 3800lm 827-865 ADV2 M3	28005396	2,700 K	827/359	-	4,110 lm	1,050 mA	33.3 V	37.2 V	-	-	112 lm/W	>80
ELA 600x600mm 3800lm 827-865 ADV2 M3	28005396	3,000 K	830/359	-	4,240 lm	1,050 mA	33.3 V	37.2 V	-	-	115 lm/W	>80
ELA 600x600mm 3800lm 827-865 ADV2 M3	28005396	4,000 K	840/359	-	4,565 lm	1,050 mA	31.6 V	35.4 V	-	-	130 lm/W	>80
ELA 600x600mm 3800lm 827-865 ADV2 M3	28005396	6,500 K	865/359	-	4,565 lm	1,050 mA	33.3 V	37.2 V	-	-	124 lm/W	>80
ELA 600x600mm 3800lm 827-865 ADV2 TPA M3	28006665	2,700 K	827/359	-	4,110 lm	1,050 mA	33.3 V	37.2 V	-	-	112 lm/W	>80
ELA 600x600mm 3800lm 827-865 ADV2 TPA M3	28006665	3,000 K	830/359	-	4,240 lm	1,050 mA	33.3 V	37.2 V	-	-	115 lm/W	>80
ELA 600x600mm 3800lm 827-865 ADV2 TPA M3	28006665	4,000 K	840/359	-	4,565 lm	1,050 mA	31.6 V	35.4 V	-	-	130 lm/W	>80
ELA 600x600mm 3800lm 827-865 ADV2 TPA M3	28006665	6,500 K	865/359	-	4,565 lm	1,050 mA	33.3 V	37.2 V	-	-	124 lm/W	>80

① Integral measurement over the complete module.

② Measured at Imax.

③ Tolerance of useful light flux - 0 % / + 15 %. Measurement uncertainty ± 10 %.

④ Tolerance of expected light flux - 0 % / + 15 %. Measurement uncertainty ± 10 %. Based on calculation.

⑤ Tolerance of power consumption Pon ± 10 %. Measurement uncertainty ± 5 %.

ELA mounting accessories ACE Surface mount kit

Accessory

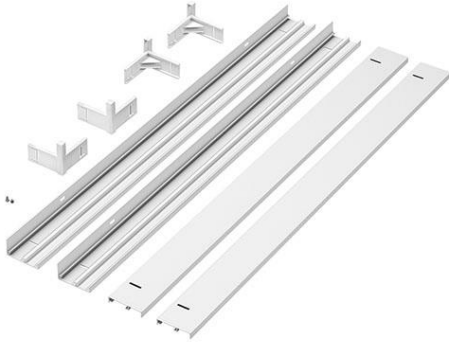

Product description

_ Aluminium frame for easy surface mounting

ACE Surface mount kit 600mm AL WH G2



Website

<http://www.tridonic.com/28003372>

ACE Surface mount kit 600mm AL WH G2 assembled

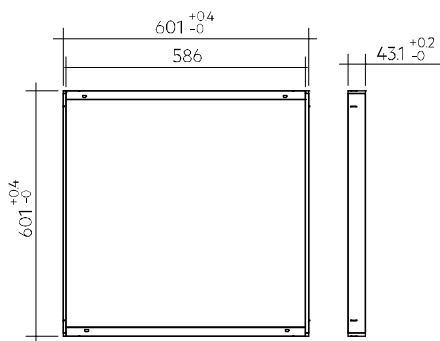

ACE Surface mount kit 600mm AL WH G2

Ordering data

Type	Article number	Colour	Packaging, carton	Weight per pc.
ACE SURFACE MOUNT KIT 600mm AL WH G2	28003372	White	20 pc(s).	0.483 kg

ELA Montagezubehör ACE Suspension kit

Accessory

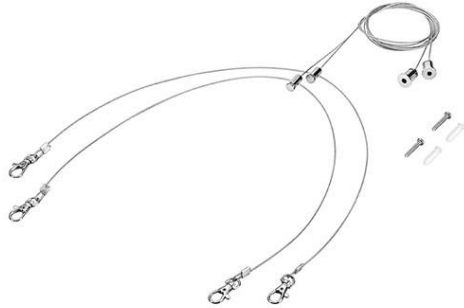
**Product description**

- _ Steel wire system for suspended mounting
- _ Suspension height up to 1.2 m

Website
<http://www.tridonic.com/28003374>

ACE Suspension kit 600-625mm STL SI G2

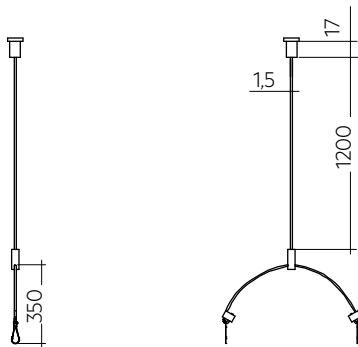

ACE Suspension kit 600-625mm STL SI G2

Ordering data

Type	Article number	Colour	Packaging, carton	Weight per pc.
ACE SUSPENSION KIT 600-625mm STL SI G2	28003374	Silver	100 pc(s).	0.097 kg

ELA mounting accessories ACE 3way CCT-SWITCH

Accessory

**Product description**

- _ Additional 3way CCT-SWITCH connector for easy CCT change among 3,000 K / 4,000 K / 6,500 K
- _ Enables the colour temperature to be changed without replacing the ELA module
- _ Switching during operation is not permitted. The LED driver must be switched off before switching.
- _ Length 400 mm
- _ Wire cross section AWG 22

Website

<http://www.tridonic.com/28003294>

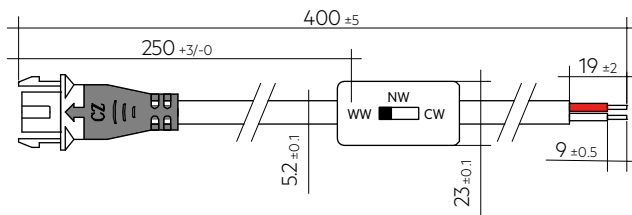
**Ordering data**

Type	Article number	Colour	Packaging, carton	Weight per pc.
ACE 3way CCT-SWITCH 400mm WH	28003294	White	50 pc(s).	0.029 kg

1. Standards

EN 62031
 EN 62471
 EN 61000-4-2
 EN 62717
 EN 60598-1

1.1 Photometric code

Key for photometric code, e. g. 830 / 359

1 st digit	2 nd + 3 rd digit	4 th digit	5 th digit	6 th digit
Code CRI	Colour temperature in Kelvin x 100	MacAdam initial	MacAdam after 25% of the lifetime (max.6000h)	Luminous flux after 25% of the lifetime (max.6000h)
7 70 – 79				Code Luminous flux
8 80 – 89				7 ≥ 70 %
9 ≥90				8 ≥ 80 % 9 ≥ 90 %

1.2 Energy classification

Type	Colour temperature	Forward current	Energy classification	Energy consumption
ELA 600x600mm 3800lm 827-865 ADV2 M3	2,700 K	900 mA	E	32 kWh / 1,000 h
ELA 600x600mm 3800lm 827-865 ADV2 M3 TPA	2,700 K	900 mA	E	32 kWh / 1,000 h

Energy label and further information at www.tridonic.com in the certificates tab of the corresponding product page and at the EPREL data base <https://eprel.ec.europa.eu/>

2. Thermal details

2.1 tc point, ambient temperature and lifetime

The temperature at tp reference point is crucial for the light output and lifetime of a LED product.

For ELA a tp temperature of 45 °C has to be complied in order to achieve an optimum between light output and lifetime.

Compliance with the maximum permissible reference temperature at the tc point must be checked under operating conditions in a thermally stable state. The maximum value must be determined under worst-case conditions for the relevant application.

The tc and tp temperature of LED modules from Tridonic are measured at the same reference point.

ELA 600x600 3800lm 827-865 ADV2 M3:

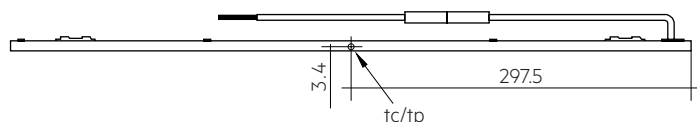

2.2 Storage and humidity

Storage temperature	-20...+50 °C
---------------------	--------------

Operation only in non condensing environment.

Humidity during operation of the module should be between 0 to 70 %.

2.3 Thermal design and heat sink

The rated life of LED products depends to a large extent on the operating temperature.

If the permissible temperature limits are exceeded, the life of the ELA will be greatly reduced or the ELA may be destroyed.

3. Installation / wiring

3.1 Electrical supply/choice of LED driver

ELA modules from Tridonic are not protected against overvoltages, overcurrents, overloads or short-circuit currents. Safe and reliable operation can only be guaranteed in conjunction with a LED driver which complies with the relevant standards. The use of LED driver from Tridonic in combination with ELA modules guarantees the necessary protection for safe and reliable operation.

If a LED driver other than Tridonic is used, it must provide the following protection:

- Short-circuit protection
- Overload protection
- Overtemperature protection



ELA modules must be supplied by a constant current LED driver. Operation with a constant voltage LED driver will lead to an irreversible damage of the module.

Wrong polarity can damage the ELA.



ELA modules must be operated with SELV LED drivers. ELA modules are not designed for parallel or serial wiring. A separate driver or output channel (for multi-channel LED drivers) must be used for each ELA module.

3.2 Wiring

Wiring diagram with CCT-SWITCH

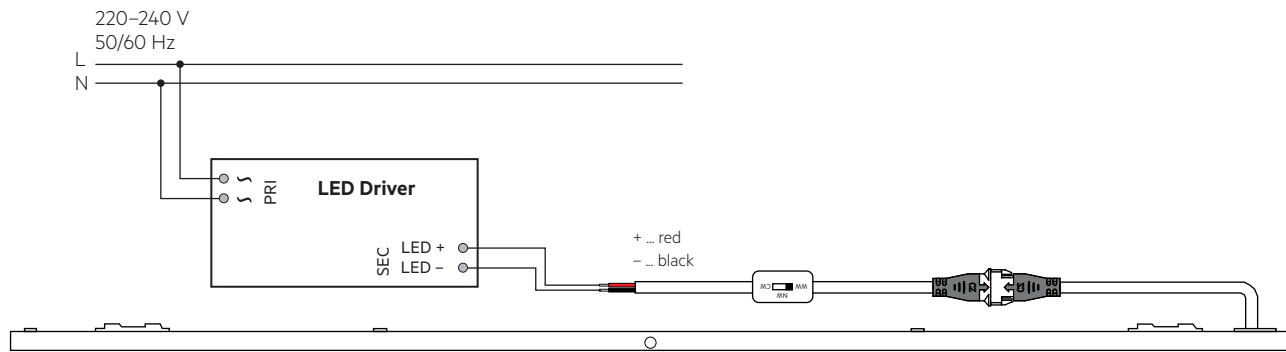

LED driver	Article number
LC 28/700/40 fixCC SC SNC4	87501108
LC 36/900/40 fixCC SC SNC4	87501110
LC 42/1050/40 fixCC SC SNC4	87501111
LC 36/700-850/42 flexC SC SNC4	87501084

Wiring diagram switchDIM and colourSWITCH with DALI Driver (28002202 – LCA 38W 350-1050mA DT8 SR PRE)

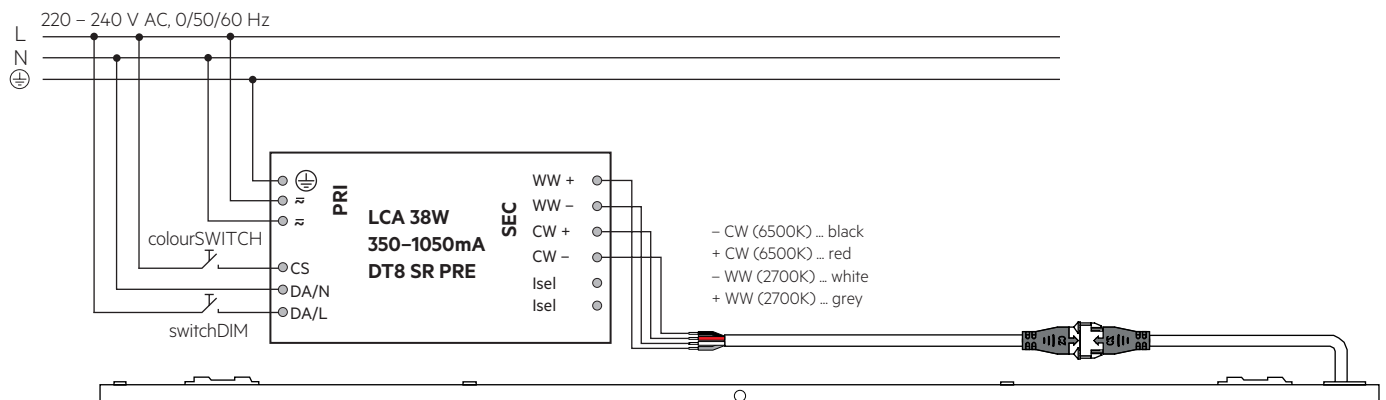

Wiring diagram DALI with DALI Driver (28002202 – LCA 38W 350-1050mA DT8 SR PRE)

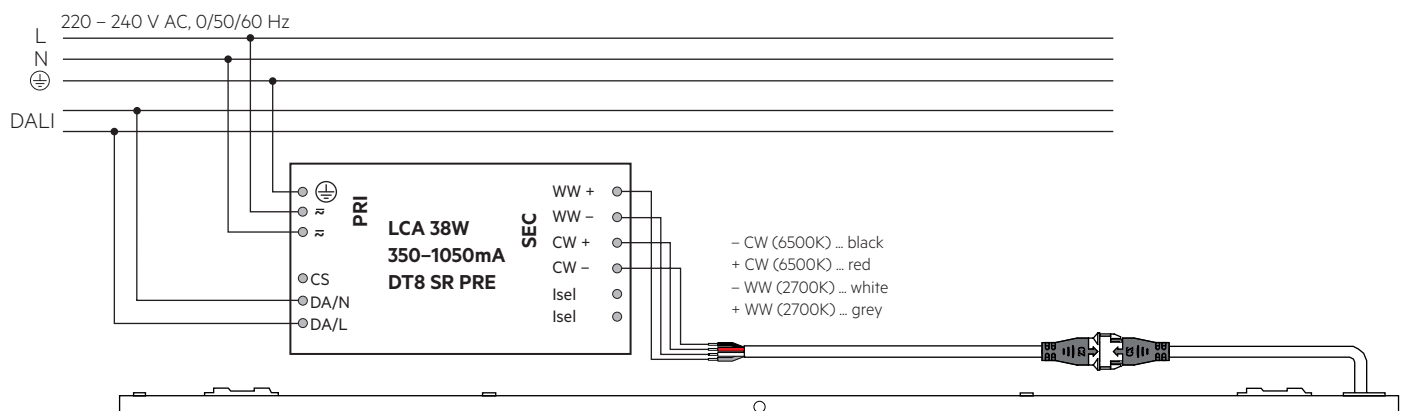

3.3 Wiring type and cross section

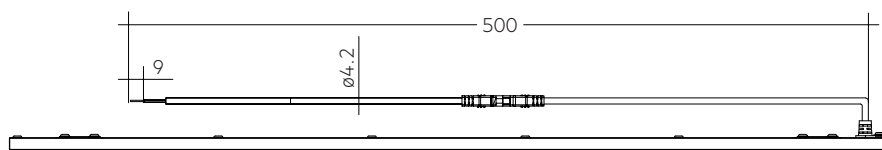

ELA has a pre-installed, flexible connection cable for easy connection of the driver during installation

Wire cross section: AWG22

Stripping length: 9 mm, pre-tinned

3.4 Mounting instruction



None of the components of the ELA (substrate, LED, electronic components etc.) may be exposed to tensile or compressive stresses.

Recessed mounting for suspended ceilings with grid measure of 600 or 625 mm.

For surface mounted applications use the ACE Surface mount kit and for suspended mounting the ACE Suspension kit.

For more details see mounting instructions.

To prevent fingerprints we recommend to mount the ELA only with gloves.



Chemical substance may harm the LED module. Chemical reactions could lead to colour shift, reduced luminous flux or a total failure of the module caused by corrosion of electrical connections.

Materials which are used in LED applications (e.g. sealings, adhesives) must not produce dissolver gas. They must not be condensation curing based, acetate curing based or contain sulfur, chlorine or phthalate.

Avoid corrosive atmosphere during usage and storage.

3.5 EOS/ESD safety guidelines



The device / module contains components that are sensitive to electrostatic discharge and may only be installed in the factory and on site if appropriate EOS/ESD protection measures have been taken. No special measures need be taken for devices/modules with enclosed casings (contact with the pc board not possible), just normal installation practice. Please note the requirements set out in the document EOS / ESD guidelines (Guideline_EOS_ESD.pdf) at: <http://www.tridonic.com/esd-protection>

4. Lifetime

4.1 Lifetime, lumen maintenance and failure rate

The light output of an LED module decreases over the lifetime, this is characterized with the L value.

L70 means that the LED module will give 70 % of its initial luminous flux. This value is always related to the number of operation hours and therefore defines the lifetime of an LED module.

The L value is a statistical value and the lumen maintenance may vary over the delivered LED modules.

The B value defines the amount of modules which are below the specific L value, e.g. L70B10 means 10 % of the LED modules are below 70 % of the initial luminous flux, respectively 90 % will be above 70 % of the initial value. In addition the percentage of failed modules (fatal failure) is characterized by the C value.

The F value is the combination of the B and C value. That means for F degradation and complete failures are considered, e.g. L70F10 means 10 % of the LED modules may fail or be below 70 % of the initial luminous flux.

4.2 Lumen maintenance for ELA

Forward current	tp temperature	L90 / B10	L90 / B50	L80 / B10	L80 / B50	L70 / B10	L70 / B50
700 /	45 °C	28k h	32k h	>50k h	>50k h	>50k h	>50k h
900 /	55 °C	28k h	32k h	>50k h	>50k h	>50k h	>50k h
1,050 mA	65 °C	25k h	28k h	>50k h	>50k h	>50k h	>50k h
	70 °C	22k h	25k h	>50k h	>50k h	>50k h	>50k h

Lumen maintenance values are based on LM80 data. Table may be updated when more recent results are available.

4.3 Switching capability

25,000 cycles

Test according to IEC 62717 Cl 10.3.3

30 s on / 30 s off at Imax

5. Electrical values

5.1 Declaration of electrical parameters

I_{rated} ... Nominal operating current the module is designed for.

I_{max} ... Max. permissible continuous operating current incl. the tolerances of the LED driver.

Max. permissible LF current ripple ... Max. output current of the LED driver incl. Tolerances and LF current ripple must not exceed this value.

Max. permissible peak current ... The max. output peak current of the LED driver must not exceed this value.

5.2 Typ. forward voltage vs. forward current

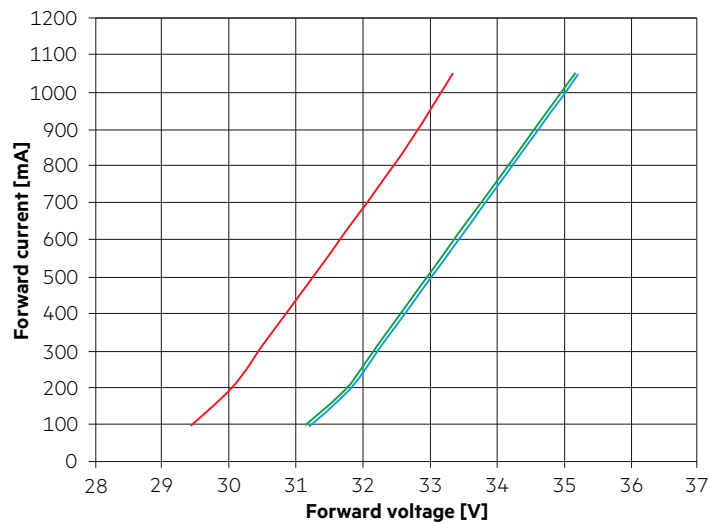

5.3 Forward voltage vs. T_c temperature

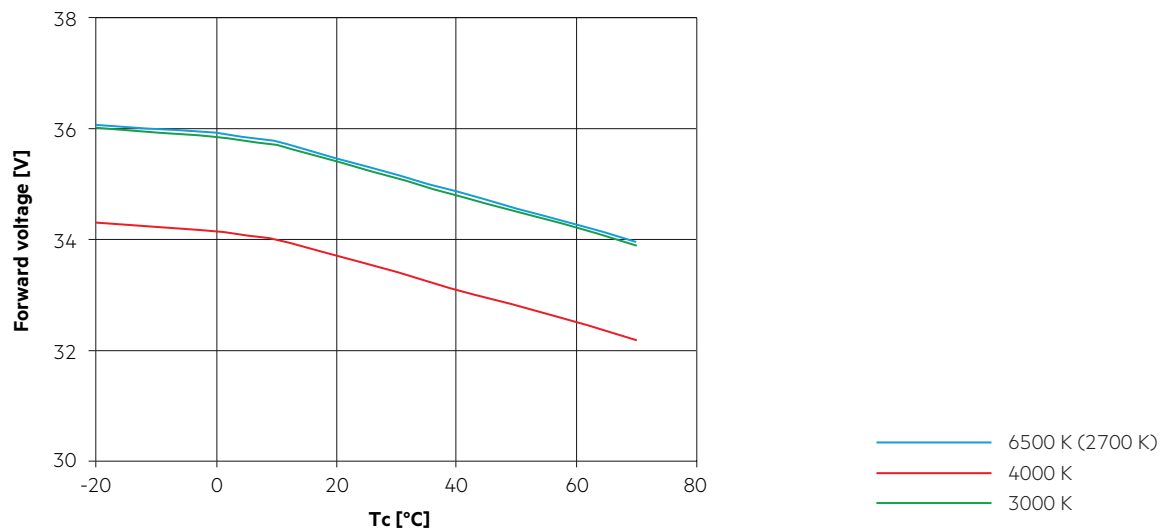

The diagrams are based on statistic values.
The real values can be different.

6. Photometric characteristics

6.1 Coordinates and tolerances according to CIE 1931

The specified colour coordinates are measured integral by a current impulse at the rated current. Integration time is 100 ms.

The ambient temperature of the measurement is $t_a = 25^\circ\text{C}$.

The measurement tolerance of the colour coordinates are ± 0.005 .

2,700 K

	x0	y0
Centre	0.4622	0.4148

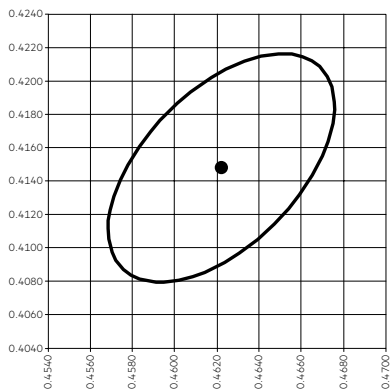

MacAdam Ellipse: 3SDCM

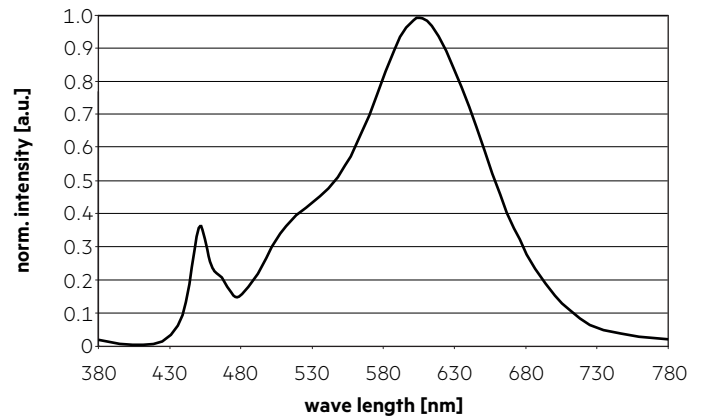

3,000 K

	x0	y0
Centre	0.4412	0.4040

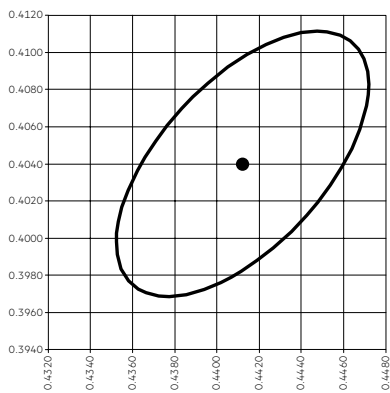

MacAdam Ellipse: 3SDCM

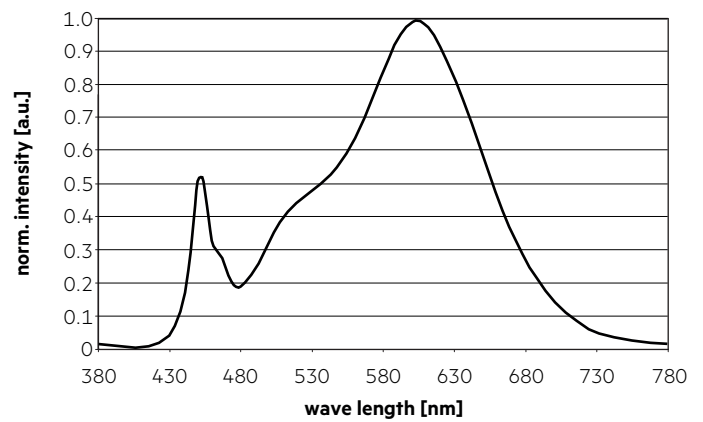

4,000 K

	x0	y0
Centre	0.3736	0.3707

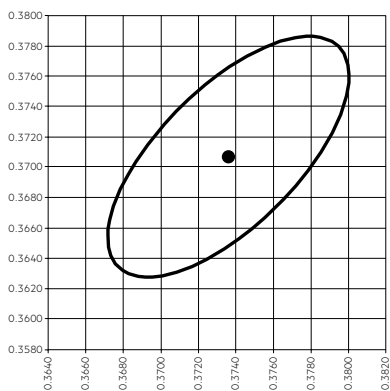

MacAdam Ellipse: 3SDCM

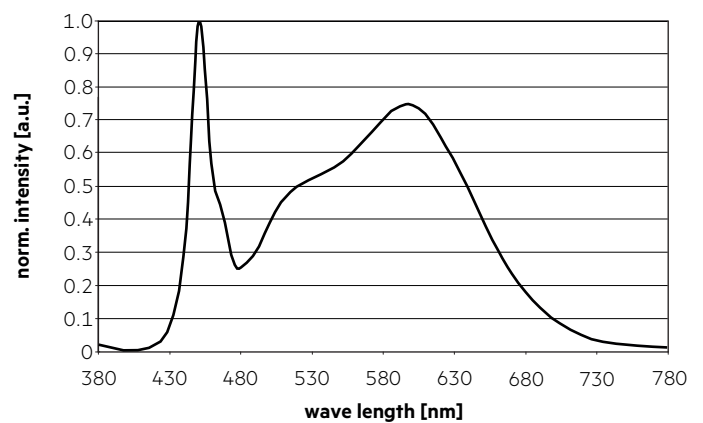

6,500 K

	x0	y0
Centre	0.3128	0.3390

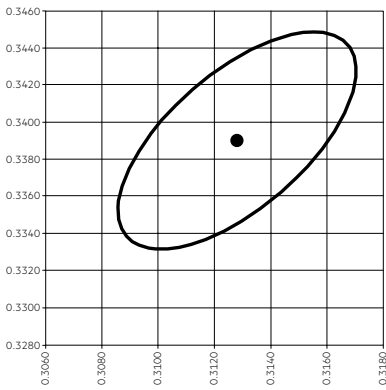

— MacAdam Ellipse: 3SDCM

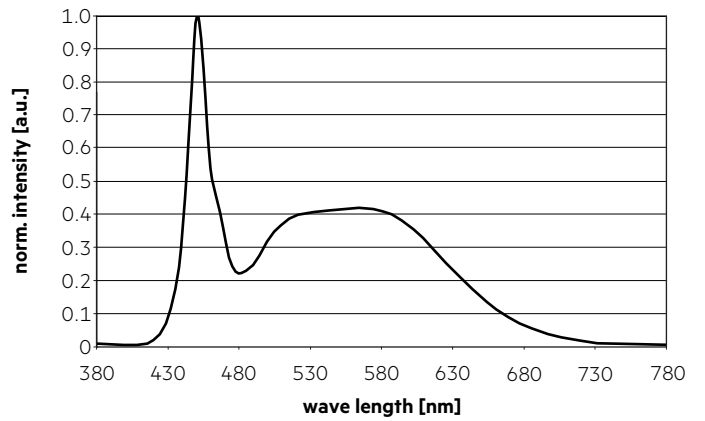

6.2 Light distribution

The optical design of the ELA product line ensures optimum homogeneity for the light distribution.

ELA 600x600 3800lm 827-865 ADV2:

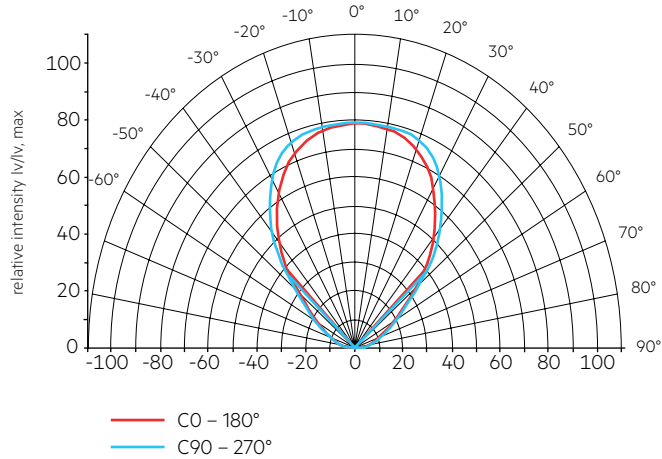

ELA 600x600 3800lm 827-865 ADV2 TPA:

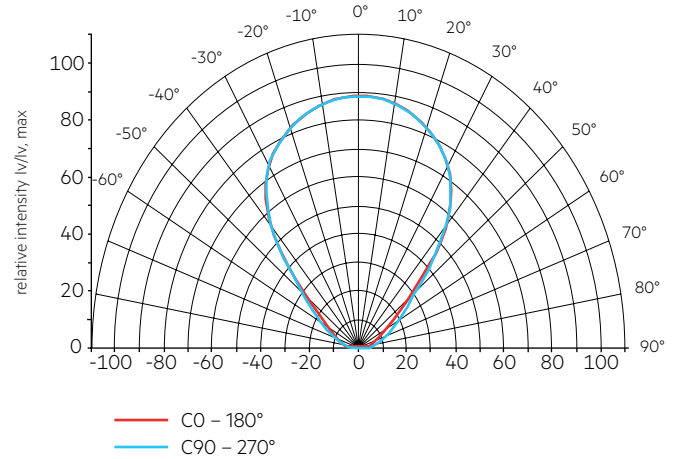

The colour temperature is measured integral over the complete module. The single LED light points can have deviations in the colour coordinates.

The random appearance of minor shining dots is state of the art and technologically inevitable. This does not qualify for returns or warranty claims.

6.3 Relative luminous flux vs. tc temperature

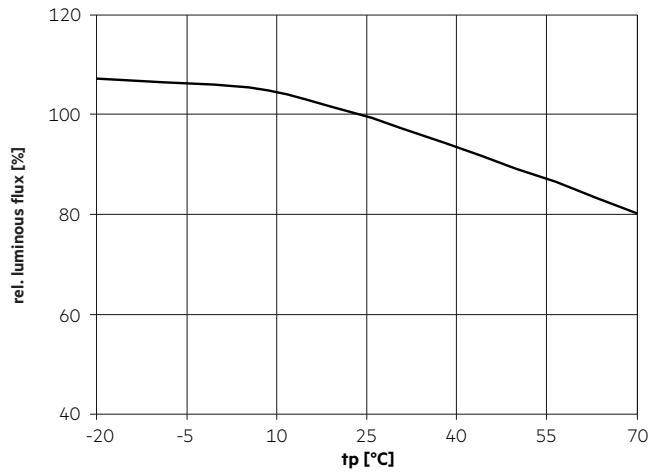

6.4 Relative luminous flux vs. operating current

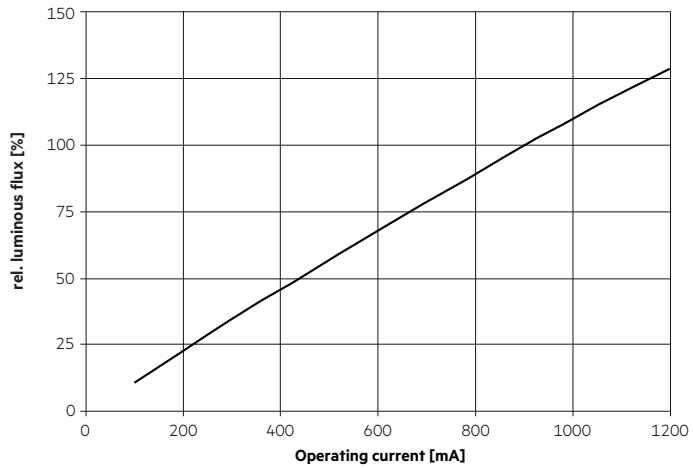

7. Miscellaneous

7.1 Additional information

Additional technical information at www.tridonic.com → Technical Data

Guarantee conditions at www.tridonic.com → Services

Lifetime declarations are informative and represent no warranty claim.