

### Driver LC 50W 350–1050mA flexC Ip EXC excite series



#### Product description

- \_ Constant current LED driver for luminaire installation
- \_ For luminaires of protection class I and protection class II
- \_ Adjustable output current between 350 and 1,050 mA via ready2mains Programmer or I-SELECT 2 plugs
- \_ Max. output power 50 W
- \_ Up to 90 % efficiency
- \_ Nominal lifetime up to 100,000 h
- \_ 5 years guarantee (Conditions at

<https://www.tridonic.com/en/int/services/manufacturer-guarantee-conditions>)

#### Housing properties

- \_ Low profile metal casing with white cover
- \_ Type of protection IP20

#### Interfaces

- \_ ready2mains (configuration via mains)
- \_ Terminal blocks: 0° push terminals

#### Functions

- \_ Adjustable output current in 1-mA-steps (ready2mains, I-SELECT 2)
- \_ Protective features (overtemperature, short-circuit, overload, no-load, input voltage range)
- \_ Suitable for emergency escape lighting systems acc. to EN 50172

#### Benefits

- \_ Application-oriented operating window for maximum compatibility
  - \_ Best energy savings due to high efficiency
  - \_ Flexible configuration via ready2mains and I-SELECT 2
  - \_ Reliability proven by lifetime up to 100,000 h and 5 years guarantee (conditions at
- <https://www.tridonic.com/en/int/services/manufacturer-guarantee-conditions>)

#### Typical applications

- \_ For linear/area lighting in office applications

#### Website

<http://www.tridonic.com/28000681>

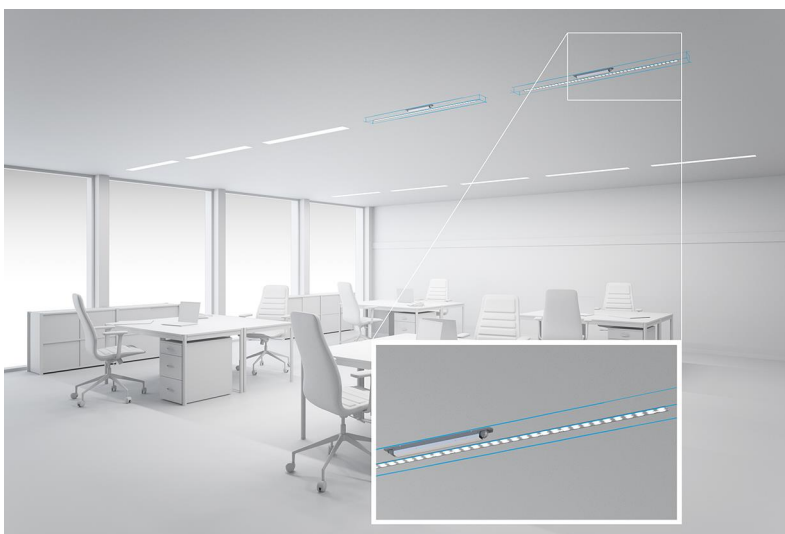

Linear



High bay



Decorative



Downlights



Spotlights



Free-standing



Area



Floor | Wall



Street

## Driver LC 50W 350–1050mA flexC Ip EXC

excite series

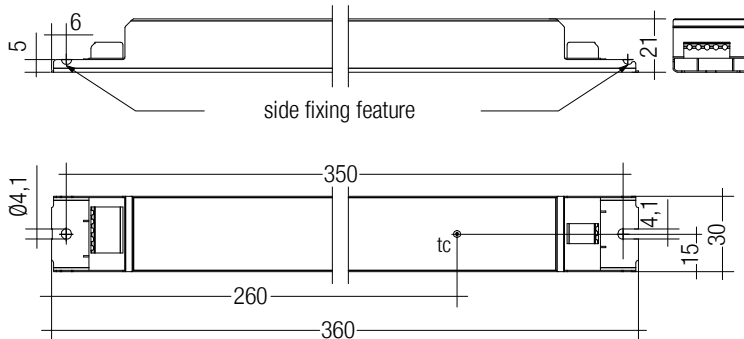

## Ordering data

| Type                           | Article number | Packaging, carton | Packaging, pallet | Weight per pc. |
|--------------------------------|----------------|-------------------|-------------------|----------------|
| LC 50W 350-1050mA flexC Ip EXC | 28000681       | 10 pc(s).         | 520 pc(s).        | 0.234 kg       |

## Technical data

|   |                              |
|---|------------------------------|
| Rated supply voltage  | 220 – 240 V                  |
| AC voltage range  | 198 – 264 V                  |
| DC voltage range  | 176 – 280 V                  |
| Mains frequency   | 0 / 50 / 60 Hz               |
| Overvoltage protection  | 320 V AC, 48 h               |
| Typ. rated current (at 230 V, 50 Hz, full load) <sup>①</sup>                      | 250 mA                       |
| Typ. current (220 V, 0 Hz, full load) <sup>②</sup>                                | 260 mA                       |
| Leakage current (at 230 V, 50 Hz, full load) <sup>①</sup>                         | < 250 $\mu$ A                |
| Max. input power  | 56.2 W                       |
| Typ. efficiency (at 230 V, 50 Hz, full load) <sup>①</sup>                         | 90 %                         |
| $\lambda$ (at 230 V, 50 Hz, full load)  | 0.98                         |
| Typ. input current in no-load operation   | 21 mA                        |
| Typ. input power in no-load operation   | 0.1 W                        |
| In-rush current (peak / duration)   | 31 A / 175 $\mu$ s           |
| THD (at 230 V, 50 Hz, full load)  | < 10 %                       |
| Starting time (at 230 V, 50 Hz, full load)  | < 500 ms                     |
| Starting time (DC mode)   | < 500 ms                     |
| Switchover time (AC/DC) <sup>③</sup>  | < 0.2 s                      |
| Turn off time (at 230 V, 50 Hz, full load)  | < 50 ms                      |
| Output current tolerance <sup>④</sup>   | $\pm$ 5 %                    |
| Max. output current peak (non-repetitive)   | $\leq$ output current + 35 % |
| Output LF current ripple (< 120 Hz)   | $\pm$ 5 %                    |
| Output P_ST_LM (at full load)   | $\leq$ 1                     |
| Output SVM (at full load)   | $\leq$ 0.4                   |
| Max. output voltage (U-OUT)   | 51.6 V                       |
| Mains surge capability (between L - N)  | 1 kV                         |
| Mains surge capability (between L/N - PE)   | 2 kV                         |
| Burst / surge peaks output side against PE  | < 0.5 kV                     |
| Type of protection  | IP20                         |
| Lifetime  | up to 100,000 h              |
| Guarantee (conditions at <a href="http://www.tridonic.com">www.tridonic.com</a> ) | 5 Year(s)                    |
| Dimensions L x W x H  | 360 x 30 x 21 mm             |

## Approval marks



## Standards

EN 55015, EN 61000-3-2, EN 61000-3-3, EN 61347-1, EN 61347-2-13, EN 62384, EN 61547, according to EN 50172, according to EN 60598-2-22

## Specific technical data

| Type                           | Output current <sup>①</sup> | Min. output voltage | Max. output voltage | Max. output power | Typ. power consumption (at 230 V, 50 Hz, full load) | Typ. current consumption (at 230 V, 50 Hz, full load) | t <sub>c</sub> point max. | Ambient temperature t <sub>a</sub> | I-SELECT 2 resistor value <sup>⑥</sup> |
|--------------------------------|-----------------------------|---------------------|---------------------|-------------------|---|---|---------------------------|------------------------------------|--|
| LC 50W 350-1050mA flexC Ip EXC | 350 mA                      | 20 V                | 50 V                | 17.5 W            | 20.6 W  | 99 mA   | 85 °C                     | -25 ... +70 °C                     | -                                      |
| LC 50W 350-1050mA flexC Ip EXC | 400 mA                      | 20 V                | 50 V                | 20.0 W            | 23.3 W  | 111 mA  | 85 °C                     | -25 ... +70 °C                     | 12.50 kΩ                               |
| LC 50W 350-1050mA flexC Ip EXC | 450 mA                      | 20 V                | 50 V                | 22.5 W            | 25.6 W  | 120 mA  | 85 °C                     | -25 ... +70 °C                     | 11.11 kΩ                               |
| LC 50W 350-1050mA flexC Ip EXC | 500 mA                      | 20 V                | 50 V                | 25.0 W            | 28.7 W  | 133 mA  | 85 °C                     | -25 ... +65 °C                     | 10.00 kΩ                               |
| LC 50W 350-1050mA flexC Ip EXC | 550 mA                      | 20 V                | 50 V                | 27.5 W            | 30.6 W  | 141 mA  | 85 °C                     | -25 ... +65 °C                     | 9.09 kΩ                                |
| LC 50W 350-1050mA flexC Ip EXC | 600 mA                      | 20 V                | 50 V                | 30.0 W            | 34.0 W  | 155 mA  | 85 °C                     | -25 ... +65 °C                     | 8.33 kΩ                                |
| LC 50W 350-1050mA flexC Ip EXC | 650 mA                      | 20 V                | 50 V                | 32.5 W            | 36.8 W  | 168 mA  | 85 °C                     | -25 ... +65 °C                     | 7.69 kΩ                                |
| LC 50W 350-1050mA flexC Ip EXC | 700 mA                      | 20 V                | 50 V                | 35.0 W            | 39.4 W  | 178 mA  | 85 °C                     | -25 ... +65 °C                     | 7.14 kΩ                                |
| LC 50W 350-1050mA flexC Ip EXC | 750 mA                      | 20 V                | 50 V                | 37.5 W            | 42.0 W  | 190 mA  | 85 °C                     | -25 ... +60 °C                     | 6.67 kΩ                                |
| LC 50W 350-1050mA flexC Ip EXC | 800 mA                      | 20 V                | 50 V                | 40.0 W            | 45.5 W  | 204 mA  | 85 °C                     | -25 ... +60 °C                     | 6.25 kΩ                                |
| LC 50W 350-1050mA flexC Ip EXC | 850 mA                      | 20 V                | 50 V                | 42.5 W            | 47.6 W  | 213 mA  | 85 °C                     | -25 ... +60 °C                     | 5.88 kΩ                                |
| LC 50W 350-1050mA flexC Ip EXC | 900 mA                      | 20 V                | 50 V                | 45.0 W            | 50.1 W  | 224 mA  | 85 °C                     | -25 ... +60 °C                     | 5.56 kΩ                                |
| LC 50W 350-1050mA flexC Ip EXC | 950 mA                      | 20 V                | 50 V                | 47.5 W            | 53.6 W  | 239 mA  | 85 °C                     | -25 ... +60 °C                     | 5.26 kΩ                                |
| LC 50W 350-1050mA flexC Ip EXC | 1,000 mA                    | 20 V                | 50 V                | 50.0 W            | 56.2 W  | 250 mA  | 85 °C                     | -25 ... +60 °C                     | 5.00 kΩ                                |
| LC 50W 350-1050mA flexC Ip EXC | 1,050 mA                    | 20 V                | 48 V                | 50.4 W            | 56.2 W  | 250 mA  | 85 °C                     | -25 ... +60 °C                     | 0.00 kΩ                                |

① Depending on the selected output current.

② Valid for Drivers with „DC new“ on the label. For old version typ. current (220 V, 0 Hz, full load, 50 % dimming level) is 129 mA.

③ Valid for immediate change of power supply type otherwise the starting time is valid.

④ Output current is mean value.

⑤ The table only lists a number of possible operating points but does not cover each single point. The output current can be set within the total value range in 1-mA-steps.

⑥ Not compatible with I-SELECT (generation 1). Calculated resistor value.

## I-SELECT 2 PLUG PRE / EXC

Accessory



## Product description

- \_ Ready-for-use resistor to set output current value
- \_ Compatible with LED driver featuring I-select 2 interface; not compatible with I-SELECT (generation 1)
- \_ Resistor is base insulated
- \_ Resistor power 0.25 W
- \_ Current tolerance  $\pm 2\%$  additional to output current tolerance
- \_ Compatible with LED driver series PRE and EXC

## Example of calculation

- \_  $R [k\Omega] = 5 V / I_{out} [mA] \times 1000$
- \_ E96 resistor value used
- \_ Resistor value tolerance  $\leq 1\%$ ; resistor power  $\geq 0.1 W$ ; base insulation necessary
- \_ When using a resistor value beyond the specified range, the output current will automatically be set to the minimum value (resistor value too big), respectively to the maximum value (resistor value too small)

## Website

<http://www.tridonic.com/28001110>



## Ordering data

| Type                      | Article number | Colour | Marking | Current  | Resistor value   | Packaging, bag | Weight per pc. |
|---------------------------|----------------|--------|---------|----------|------------------|----------------|----------------|
| I-SELECT 2 PLUG 350MA BL  | 28001110       | Blue   | 0350 mA | 350 mA   | 14.30 k $\Omega$ | 10 pc(s).      | 0.001 kg       |
| I-SELECT 2 PLUG 375MA BL  | 28001111       | Blue   | 0375 mA | 375 mA   | 13.30 k $\Omega$ | 10 pc(s).      | 0.001 kg       |
| I-SELECT 2 PLUG 400MA BL  | 28001112       | Blue   | 0400 mA | 400 mA   | 12.40 k $\Omega$ | 10 pc(s).      | 0.001 kg       |
| I-SELECT 2 PLUG 425MA BL  | 28001251       | Blue   | 0425 mA | 425 mA   | 11.80 k $\Omega$ | 10 pc(s).      | 0.001 kg       |
| I-SELECT 2 PLUG 450MA BL  | 28001113       | Blue   | 0450 mA | 450 mA   | 11.00 k $\Omega$ | 10 pc(s).      | 0.001 kg       |
| I-SELECT 2 PLUG 475MA BL  | 28001252       | Blue   | 0475 mA | 475 mA   | 10.50 k $\Omega$ | 10 pc(s).      | 0.001 kg       |
| I-SELECT 2 PLUG 500MA BL  | 28001114       | Blue   | 0500 mA | 500 mA   | 10.00 k $\Omega$ | 10 pc(s).      | 0.001 kg       |
| I-SELECT 2 PLUG 525MA BL  | 28001960       | Blue   | 0525 mA | 525 mA   | 9.53 k $\Omega$  | 10 pc(s).      | 0.001 kg       |
| I-SELECT 2 PLUG 550MA BL  | 28001115       | Blue   | 0550 mA | 550 mA   | 9.09 k $\Omega$  | 10 pc(s).      | 0.001 kg       |
| I-SELECT 2 PLUG 600MA BL  | 28001116       | Blue   | 0600 mA | 600 mA   | 8.25 k $\Omega$  | 10 pc(s).      | 0.001 kg       |
| I-SELECT 2 PLUG 650MA BL  | 28001117       | Blue   | 0650 mA | 650 mA   | 7.68 k $\Omega$  | 10 pc(s).      | 0.001 kg       |
| I-SELECT 2 PLUG 700MA BL  | 28001118       | Blue   | 0700 mA | 700 mA   | 7.15 k $\Omega$  | 10 pc(s).      | 0.001 kg       |
| I-SELECT 2 PLUG 750MA BL  | 28001119       | Blue   | 0750 mA | 750 mA   | 6.65 k $\Omega$  | 10 pc(s).      | 0.001 kg       |
| I-SELECT 2 PLUG 800MA BL  | 28001120       | Blue   | 0800 mA | 800 mA   | 6.19 k $\Omega$  | 10 pc(s).      | 0.001 kg       |
| I-SELECT 2 PLUG 850MA BL  | 28001121       | Blue   | 0850 mA | 850 mA   | 5.90 k $\Omega$  | 10 pc(s).      | 0.001 kg       |
| I-SELECT 2 PLUG 900MA BL  | 28001122       | Blue   | 0900 mA | 900 mA   | 5.62 k $\Omega$  | 10 pc(s).      | 0.001 kg       |
| I-SELECT 2 PLUG 950MA BL  | 28001123       | Blue   | 0950 mA | 950 mA   | 5.23 k $\Omega$  | 10 pc(s).      | 0.001 kg       |
| I-SELECT 2 PLUG 1000MA BL | 28001124       | Blue   | 1000 mA | 1,000 mA | 4.99 k $\Omega$  | 10 pc(s).      | 0.001 kg       |
| I-SELECT 2 PLUG 1050MA BL | 28001125       | Blue   | 1050 mA | 1,050 mA | 4.75 k $\Omega$  | 10 pc(s).      | 0.001 kg       |
| I-SELECT 2 PLUG MAX BL    | 28001099       | Blue   | MAX     | MAX      | 0.00 k $\Omega$  | 10 pc(s).      | 0.001 kg       |

## 1. Standards

EN 55015  
 EN 61000-3-2  
 EN 61000-3-3  
 EN 61347-1  
 EN 61347-2-13  
 EN 62384  
 EN 61547

According to EN 50172 for use in central battery systems

According to EN 60598-2-22 suitable for emergency lighting installations

## 2. Thermal details and lifetime

### 2.1 Expected lifetime

| Expected lifetime              |                  |          |             |             |             |             |          |          |
|--------------------------------|------------------|----------|-------------|-------------|-------------|-------------|----------|----------|
| Type                           | Output current   | ta       | 40 °C       | 50 °C       | 55 °C       | 60 °C       | 65 °C    | 70 °C    |
|                                | < 500 mA         | tc       | 55 °C       | 65 °C       | 70 °C       | 75 °C       | 80 °C    | 85 °C    |
|                                |                  | Lifetime | > 100,000 h | > 100,000 h | > 100,000 h | > 100,000 h | 95,000 h | 70,000 h |
| LC 50W 350-1050mA flexC Ip EXC | 500 – 700 mA     | tc       | 60 °C       | 70 °C       | 75 °C       | 80 °C       | 85 °C    | –        |
|                                |                  | Lifetime | > 100,000 h | > 100,000 h | > 100,000 h | > 100,000 h | 80,000 h | –        |
|                                | > 700 – 1,050 mA | tc       | 65 °C       | 75 °C       | 80 °C       | 85 °C       | –        | –        |
|                                |                  | Lifetime | > 100,000 h | > 100,000 h | > 100,000 h | 75,000 h    | –        | –        |

The LED driver is designed for a lifetime stated above under reference conditions and with a failure probability of less than 10 %.

The relation of tc to ta temperature depends also on the luminaire design.

If the measured tc temperature is approx. 5 K below tc max., ta temperature should be checked and eventually critical components (e.g. ELCAP) measured. Detailed information on request.

## 3. Installation / wiring

### 3.1 Circuit diagram

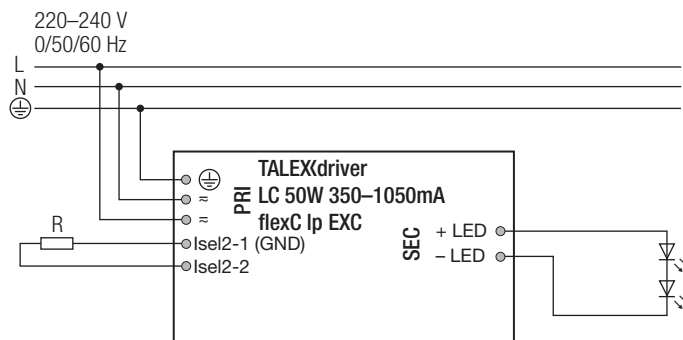

### 3.2 Wiring type and cross section

For wiring use solid wire from 0.5 – 1.5 mm<sup>2</sup>.

Strip 8 – 9 mm of insulation from the cables to ensure perfect operation of terminals.

LED module/LED driver/supply

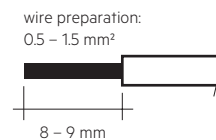

### 3.3 Loose wiring

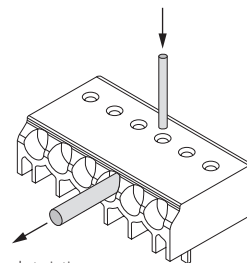

Loosen wire through twisting and pulling or using a Ø 1 mm release tool

3.4 Wiring guidelines

- The cables should be run separately from the mains connections and mains cables to ensure good EMC conditions.
- The LED wiring should be kept as short as possible to ensure good EMC. The max. secondary cable length is 2 m (4 m circuit).
- Secondary switching is not permitted.
- The LED driver has no inverse-polarity protection on the secondary side. Wrong polarity can damage LED modules with no inverse-polarity protection.
- Wrong wiring of the LED driver can lead to malfunction or irreparable damage.
- To avoid damage of the Driver, the wiring must be protected against short circuits to earth (sharp edged metal parts, metal cable clips, louver, etc.).

3.5 Hot plug-in

Hot plug-in is not supported due to residual output voltage of > 0 V. When connecting an LED load, restart the device to activate the LED output. This can be done via mains reset.

3.6 Earth connection

The earth connection is conducted as protection earth (PE). If the LED driver will be earthed, protection earth (PE) has to be used. There is no earth connection required for the functionality of the LED driver. Earth connection is recommended to improve following behaviour:

- Electromagnetic interferences (EMI)
- Transmission of mains transients to the LED output

In general it is recommended to earth the LED driver if the LED module is mounted on earthed luminaire parts respectively heat sinks and thereby representing a high capacity against earth.

3.7 I-SELECT 2 resistors connected via cable

For details see: [http://www.tridonic.com/com/en/download/technical/LCA\\_PRE\\_LC\\_EXC\\_ProductManual\\_en.pdf](http://www.tridonic.com/com/en/download/technical/LCA_PRE_LC_EXC_ProductManual_en.pdf).

4. Electrical values

4.1 Operating window

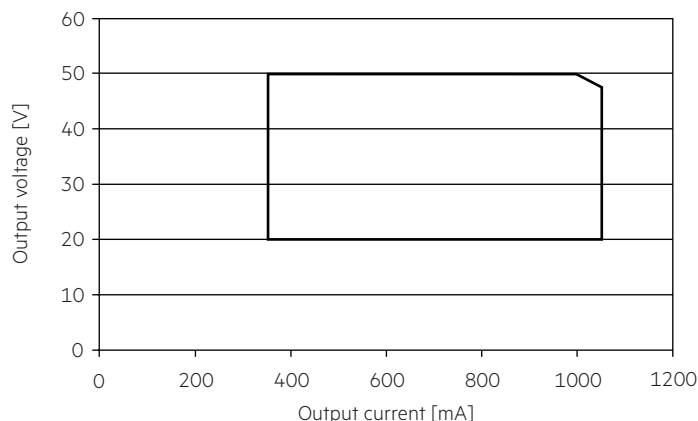

Make sure that the LED driver is operated within the given window under all operating conditions. Coming below the specified minimum output voltage of the LED driver may cause the device to shut-down.

4.2 Efficiency vs load

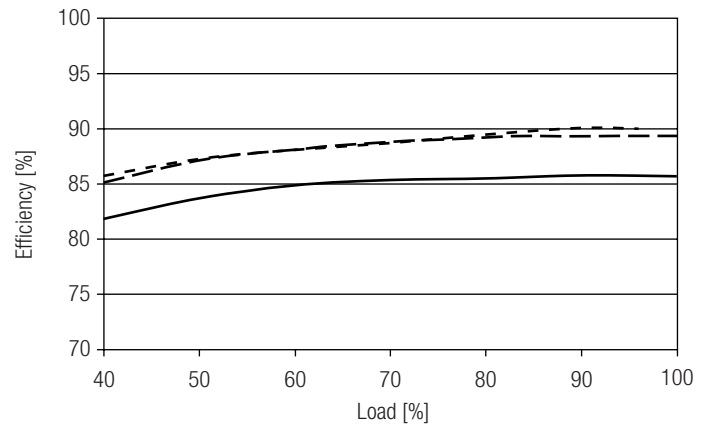

4.3 Power factor vs load

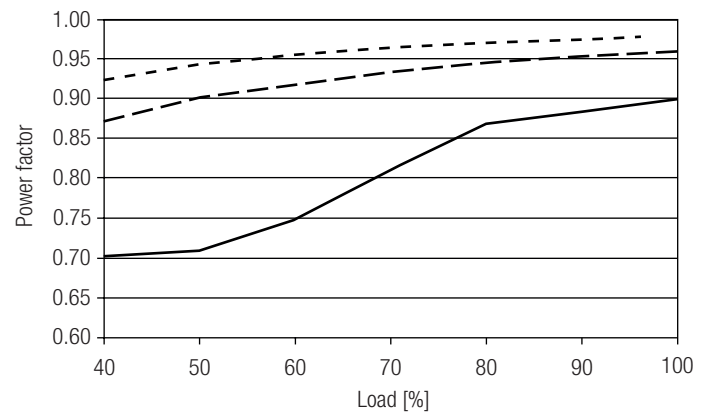

4.4 THD vs load (without harmonic < 5 mA or 0.6 % of the input current)

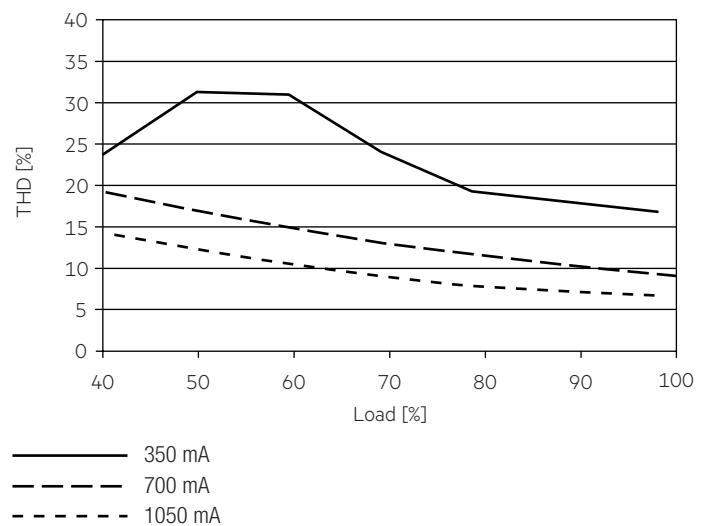

100 % load corresponds to the max. output power (full load) according to the table on page 2.

#### 4.5 Maximum loading of automatic circuit breakers in relation to inrush current

| Automatic circuit breaker type        | C10                 | C13                 | C16                 | C20                 | B10                 | B13                 | B16                 | B20                 | Inrush current |        |
|---------------------------------------|---------------------|---------------------|---------------------|---------------------|---------------------|---------------------|---------------------|---------------------|----------------|--------|
| Installation Ø                        | 1.5 mm <sup>2</sup> | 1.5 mm <sup>2</sup> | 2.5 mm <sup>2</sup> | 2.5 mm <sup>2</sup> | 1.5 mm <sup>2</sup> | 1.5 mm <sup>2</sup> | 2.5 mm <sup>2</sup> | 2.5 mm <sup>2</sup> | $I_{max}$      | time   |
| <b>LC 50W 350-1050mA flexC Ip EXC</b> | 23                  | 30                  | 38                  | 46                  | 14                  | 18                  | 23                  | 28                  | 31 A           | 175 µs |

These are max. values calculated out of inrush current! Please consider not to exceed the maximum rated continuous current of the circuit breaker. Calculation uses typical values from ABB series S200 as a reference. Actual values may differ due to used circuit breaker types and installation environment.

#### 4.6 Harmonic distortion in the mains supply (at 230 V / 50 Hz and full load) in %

|                                       | THD | 3.  | 5.  | 7.  | 9.  | 11. |
|---------------------------------------|-----|-----|-----|-----|-----|-----|
| <b>LC 50W 350-1050mA flexC Ip EXC</b> | < 8 | < 5 | < 2 | < 3 | < 3 | < 2 |

## 5. Interfaces / communication

### 5.1 Configuration input ready2mains (L, N)

The digital ready2mains protocol is modulated onto the mains signal which is wired to the mains terminal (L and N).

## 6. Functions

### 6.1 Function: adjustable current

The output current of the LED driver can be adjusted in a certain range. For adjustment there are two options available.

#### Option 1: I-SELECT 2

By inserting a suitable resistor or third party resistor into the I-SELECT 2 interface, the current value can be adjusted. The relationship between output current and resistor value can be found in the chapter "Accessories I-SELECT 2 Plugs".



Please note that the resistor values for I-SELECT 2 are not compatible with I-SELECT (generation 1). Installation of an incorrect resistor may cause irreparable damage to the LED module(s).

Resistors for the main output current values can be ordered from Tridonic (see accessories).

#### Option 2: ready2mains

Adjustment is done by the ready2mains programmer and the corresponding configuration software (see ready2mains documentation).



Current adjustment can only be done five times over ready2mains. To program the LED driver a connected load is necessary that is within the operating window of the LED driver.

The priority for current adjustment methods is I-SELECT 2 followed by ready2mains (lowest priority).

### 6.2 ready2mains – configuration

The ready2mains interface enables the configuration of the mostly used parameters via the mains wiring. In the case of EXC LED driver, it is the LED output current as well as an optional lockbit to prevent any accidental configuration at a later stage.

The configuration is done via the ready2mains Programmer, either directly at the Programmer itself or via a respective software tool. For details on the configuration via ready2mains see the technical information of the Programmer and its tools.

### 6.3 Short-circuit behaviour

In case of a short-circuit at the LED output the LED output is switched off. After restart of the LED driver the output will be activated again. The restart can be done via mains reset.

### 6.4 No-load operation

The LED driver will not be damaged in no-load operation. The output will be deactivated and is therefore free of voltage. If a LED load is connected the device has to be restarted before the output will be activated again.

### 6.5 Overload protection

If the maximum load is exceeded by a defined internal limit, the LED driver turns off the LED output. After restart of the LED driver the output will be activated again. The restart can be done via mains reset.

### 6.6 Overtemperature protection

The LED driver is protected against temporary thermal overheating. If the temperature limit is exceeded the output current of the LED module(s) is reduced. The temperature protection is activated above  $t_{c max}$ . The activation temperature differs depending on the LED load. On DC operation this function is deactivated to fulfill emergency requirements.

### 6.7 DC emergency operation

The LED driver is designed to operate on DC voltage and pulsed DC voltage.

Light output level in DC operation (EOFx): 95 % (cannot be adjusted).

The voltage-dependent input current of Driver incl. LED module is depending on the used load.

The nominal voltage-dependent no-load current of Driver (without or defect LED module) is for:

AC: < 21.3 mA (at 230 V, 50 Hz)

DC: 14 – 23 mA (at 275 – 186 V, 0 Hz)

## 7. Miscellaneous

### 7.1 Insulation and electric strength testing of luminaires

Electronic devices can be damaged by high voltage. This has to be considered during the routine testing of the luminaires in production.

According to IEC 60598-1 Annex Q (informative only!) or ENEC 303-Annex A, each luminaire should be submitted to an insulation test with 500 V<sub>DC</sub> for one second. This test voltage should be connected between the interconnected phase and neutral terminals and the earth terminal. The insulation resistance must be at least 2 MΩ.

As an alternative, IEC 60598-1 Annex Q describes a test of the electrical strength with 1500 V<sub>AC</sub> (or 1.414 x 1500 V<sub>DC</sub>). To avoid damage to the electronic devices this test must not be conducted.

### 7.2 Conditions of use and storage

Humidity: 5 % up to max. 85 %,  
not condensed  
(max. 56 days/year at 85 %)

Storage temperature: -40 °C up to max. +80 °C

The devices have to be acclimatised to the specified temperature range (ta) before they can be operated.

The LED driver is declared as inbuilt LED controlgear, meaning it is intended to be used within a luminaire enclosure.

If the product is used outside a luminaire, the installation must provide suitable protection for people and environment (e.g. in illuminated ceilings).

### 7.3 Maximum number of switching cycles

All LED driver are tested with 50,000 switching cycles.  
The actually achieved number of switching cycles is significantly higher.

### 7.4 Additional information

Additional technical information at [www.tridonic.com](http://www.tridonic.com) → Technical Data

Lifetime declarations are informative and represent no warranty claim.  
No warranty if device was opened.