

**Driver LC 34W 500-800mA flexC T SNC4**

essence in-track series (1-phase system)



Black (RAL 9005)



White (RAL 9003)



Grey (RAL 7035)

**Product description**

- \_ Constant current / in-track LED driver
- \_ Accessory ACU ALU NIPPLE M10x1 for mounting the luminaire head included, but not pre-assembled
- \_ Compatible 1-phase system in-tracks, see data sheet chapter 3.8
- \_ For luminaires of protection class II
- \_ Temperature protection as per EN 61347-2-13 C5e
- \_ Selectable fixed output current via DIP switch 500, 600, 700 and 800 mA (pre-selected current 500 mA)
- \_ Max. output power 33.6 W
- \_ Up to 88 % efficiency
- \_ Nominal lifetime up to 100,000 h
- \_ BIS approval mark for art. no.: 87501162 and 87501165
- \_ 5 years guarantee (Conditions at <https://www.tridonic.com/en/int/services/manufacturer-guarantee-conditions>)

**Housing properties**

- \_ Casing: polycarbonate, black, white or grey
- \_ Type of protection IP20

**Functions**

- \_ Overload protection
- \_ Short-circuit protection
- \_ No-load protection

**Typical applications**

- \_ For spot light in retail and hospitality application

**Website**

<http://www.tridonic.com/87501162>



Linear



High bay



Decorative



Downlights



Spotlights



Free-standing



Area



Floor | Wall



Street

## Driver LC 34W 500-800mA flexC T SNC4

essence in-track series (1-phase system)

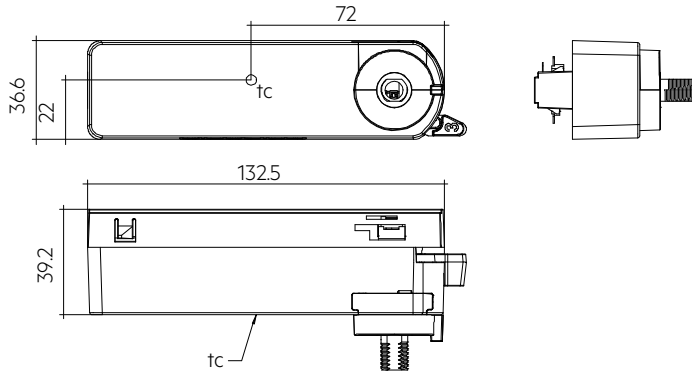

## Ordering data

Type	Article number	Colour	Packaging, carton	Packaging, low volume	Packaging, high volume	Weight per pc.
LC 34/500-800/42 flexC T-B SNC4	87501162	Black	50 pc(s).	400 pc(s).	1,200 pc(s).	0.100 kg
LC 34/500-800/42 flexC T-W SNC4	87501165	White	50 pc(s).	400 pc(s).	1,200 pc(s).	0.101 kg
LC 34/500-800/42 flexC T-G SNC4	87501168	Grey	50 pc(s).	400 pc(s).	1,200 pc(s).	0.101 kg

## Technical data

Rated supply voltage	220 – 240 V
AC voltage range	198 – 264 V
Max. input current (at 230 V, 50 Hz, full load)	0.225 A
Leakage current (at 230 V, 50 Hz, full load)	< 450 $\mu$ A
Mains frequency	50 / 60 Hz
Overvoltage protection	320 V AC, 2 h
Typ. power consumption (at 230 V, 50 Hz, full load)	37.5 W
Min. output power	15 W
Max. output power	33.6 W
Typ. efficiency (at 230 V, 50 Hz, full load)	88 %
$\lambda$ over full operating range (max.)	0.98
$\lambda$ over full operating range (min.)	0.9C
Output current tolerance <sup>①</sup>	$\pm$ 7.5 %
Max. output current peak <sup>②</sup>	896 mA
Max. output voltage (U-OUT)	59 V
THD (at 230 V, 50 Hz, full load)	< 12 %
Output LF current ripple (< 120 Hz)	$\pm$ 5 %
Output P_ST_LM (at full load)	$\leq$ 1
Output SVM (at full load)	$\leq$ 0.4
Starting time (at 230 V, 50 Hz, full load)	< 0.5 s
Turn off time (at 230 V, 50 Hz, full load)	$\leq$ 0.5 s
Hold on time at power failure (output)	0 s
Ambient temperature $t_a$ (at lifetime 100,000 h)	25 °C
Storage temperature $t_s$	-25 ... +80 °C
Mains surge capability (between L - N)	1 kV
Mains surge capability (between L/N - PE)	2 kV
Surge voltage at output side (against PE)	< 3 kV
Lifetime	up to 100,000 h
Guarantee (conditions at <a href="http://www.tridonic.com">www.tridonic.com</a> )	5 Year(s)
Dimensions L x W x H	140.6 x 36.6 x 59.8 mm

## Approval marks



## Standards

EN 55015, EN 61000-3-2, EN 61000-3-3, EN 61347-1, EN 61347-2-13, EN 61547, EN 61000-4-4, EN 61000-4-5

## Specific technical data

Type	Output current <sup>①</sup>	Min. output voltage	Max. output voltage	Max. output power	Typ. power consumption (at 230 V, 50 Hz, full load)	Typ. current consumption (at 230 V, 50 Hz, full load)	tc point max.	Ambient temperature ta	I-out select
LC 34/500-800/42 flexC T-B SNC4	500 mA	30 V	42 V	21.0 W	23.7 W	106 mA	65 °C	-20 ... +35 °C	1=off / 2=off
LC 34/500-800/42 flexC T-B SNC4	600 mA	30 V	42 V	25.2 W	28.3 W	126 mA	65 °C	-20 ... +35 °C	1=off / 2=on
LC 34/500-800/42 flexC T-B SNC4	700 mA	30 V	42 V	29.4 W	33.4 W	149 mA	65 °C	-20 ... +35 °C	1=on / 2=off
LC 34/500-800/42 flexC T-B SNC4	800 mA	30 V	42 V	33.6 W	37.5 W	167 mA	70 °C	-20 ... +35 °C	1=on / 2=on
LC 34/500-800/42 flexC T-W SNC4	500 mA	30 V	42 V	21.0 W	23.7 W	106 mA	65 °C	-20 ... +35 °C	1=off / 2=off
LC 34/500-800/42 flexC T-W SNC4	600 mA	30 V	42 V	25.2 W	28.3 W	126 mA	65 °C	-20 ... +35 °C	1=off / 2=on
LC 34/500-800/42 flexC T-W SNC4	700 mA	30 V	42 V	29.4 W	33.4 W	149 mA	65 °C	-20 ... +35 °C	1=on / 2=off
LC 34/500-800/42 flexC T-W SNC4	800 mA	30 V	42 V	33.6 W	37.5 W	167 mA	70 °C	-20 ... +35 °C	1=on / 2=on
LC 34/500-800/42 flexC T-G SNC4	500 mA	30 V	42 V	21.0 W	23.7 W	106 mA	65 °C	-20 ... +35 °C	1=off / 2=off
LC 34/500-800/42 flexC T-G SNC4	600 mA	30 V	42 V	25.2 W	28.3 W	126 mA	65 °C	-20 ... +35 °C	1=off / 2=on
LC 34/500-800/42 flexC T-G SNC4	700 mA	30 V	42 V	29.4 W	33.4 W	149 mA	65 °C	-20 ... +35 °C	1=on / 2=off
LC 34/500-800/42 flexC T-G SNC4	800 mA	30 V	42 V	33.6 W	37.5 W	167 mA	70 °C	-20 ... +35 °C	1=on / 2=on

① Output current is mean value.

② Test result at 25 °C.

## 1. Standards

EN 55015  
 EN 61000-3-2  
 EN 61000-3-3  
 EN 61347-1  
 EN 61347-2-13  
 EN 61547  
 EN 61000-4-4  
 EN 61000-4-5

### 1.1 Glow-wire test

according to EN 61347-1 with increased temperature of 850 °C passed.

## 2. Thermal details and lifetime

### 2.1 Expected lifetime

#### Expected lifetime

Type	ta	25 °C	35 °C
LC 34/500-800/42 flexC T SNC4	Lifetime	> 100,000 h	50,000 h

<sup>①</sup> Test result at max. output voltage.

The LED drivers are designed for a lifetime stated above under reference conditions and with a failure probability of less than 10 %.

Temperatures were measured with Tracktype PRO-310 from manufacturer powergear. Temperatures can deviate with tracks from other manufacturers.

## 3. Installation / wiring

### 3.1 Circuit diagram

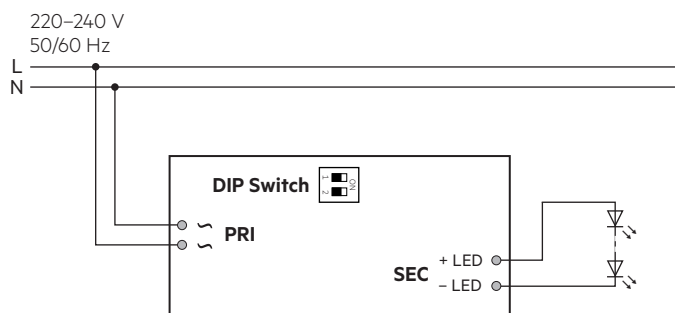

### 3.2 Wiring type and cross section

For wiring use solid wire from 0.2–0.75 mm<sup>2</sup>.  
 Strip 7–9 mm of insulation from the cables to ensure perfect operation of the push-wire terminals.  
 Use one wire for each terminal connector only.

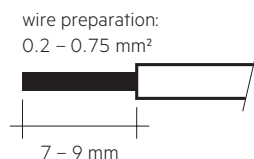

Inserting stranded wires / removing wires by lightly pressing on the push button.

### 3.3 Fixing conditions

Dry, acidfree, oilfree, fatfree. It is not allowed to exceed the maximum ambient temperature (ta) stated on the device.

### 3.4 Wiring guidelines

- All connections must be kept as short as possible to ensure good EMI behaviour.
- Max. length of output wires is 20 cm.
- Secondary switching is not permitted.
- Incorrect wiring can damage LED modules.
- To avoid damage of the Driver, the wiring must be protected against short circuits to earth (sharp edged metal parts, metal cable clips, louver, etc.).

### 3.5 Replace LED module

1. Mains off
2. Remove LED module
3. Wait for 10 seconds
4. Connect LED module again

Hot plug-in or secondary switching of LEDs is not permitted and may cause a very high current to the LEDs.

### 3.6 Mounting luminaire

Max. allowed weight of complete luminaire: 5 kg (50 N)

### 3.7 Compatible 1-phase tracks

Subject to be changed without notice.

Manufacturer	Type	Casing colour
powergear	PRO-0310-W	white (RAL 9010)
powergear	PRO-0310-S	silver (RAL7040)
powergear	PRO-0310-B	black (RAL9011)
SAL	STR4800/1 WH	1M TRACK, white
SAL	STR4800/1 BK	1M TRACK, black
SAL	STR4800/2 WH	2M TRACK, white
SAL	STR4800/2 BK	2M TRACK, black

Tests have been done with in-tracks taken from the market in the first half of 2018.



Tridonic has no control or responsibility on any future or past possible changes made by different manufactures that could affect the compatibility between tracks and adapters.

### 3.8 Mounting into the track

Insert the guide rail head into the track so that one side (B) of the copper plate in the guide rail head matches the groove (A) in the track. Rotate the handle lever (C) about 90° until it reaches the locking position. Open and rotate the lever in the opposite direction.

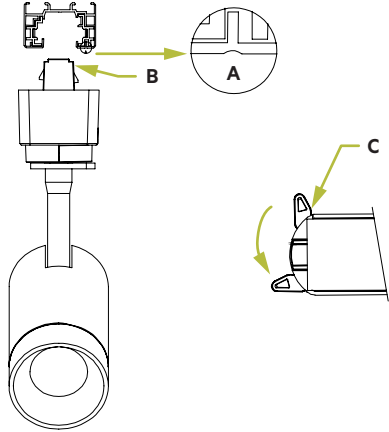

1. Take out the box.

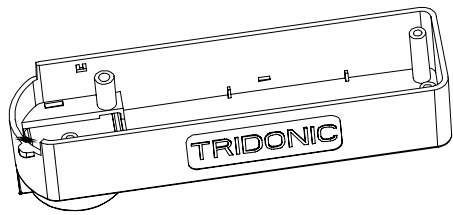

2. Install the PCB board.

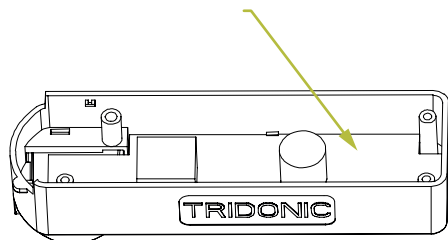

3. Install the base assembly.



4. The nipple is twisted into the lamp body bracket.

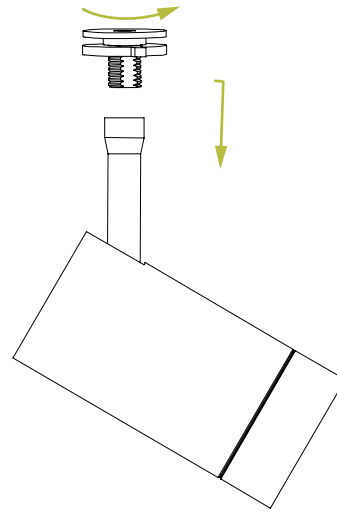

5. Put the twisted tooth tube into the guide rail box slot.

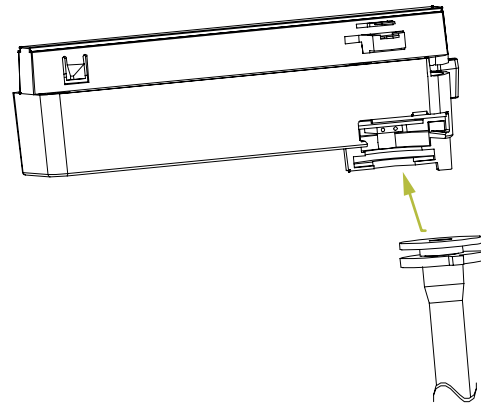

6. Install the side cover.

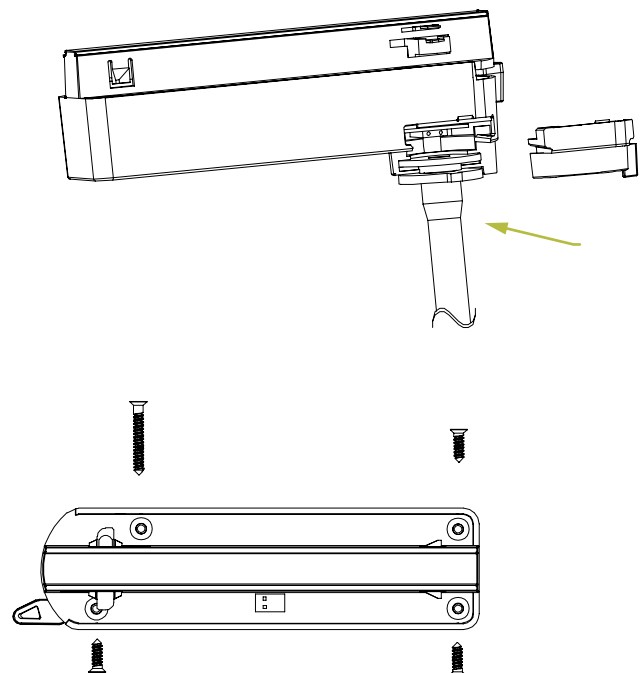

7. Installation completed.

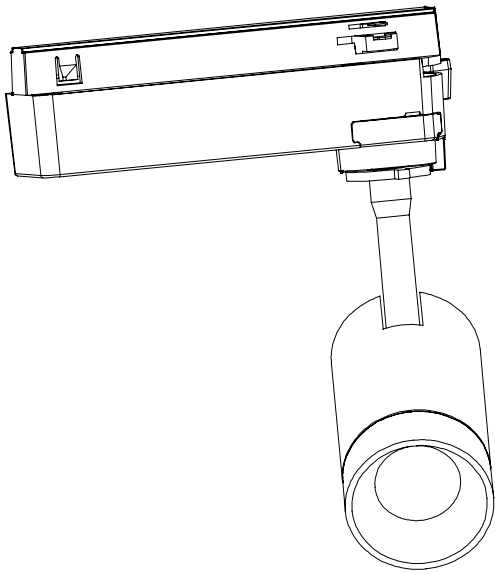

#### 4. Electrical values

##### 4.1 Efficiency vs load

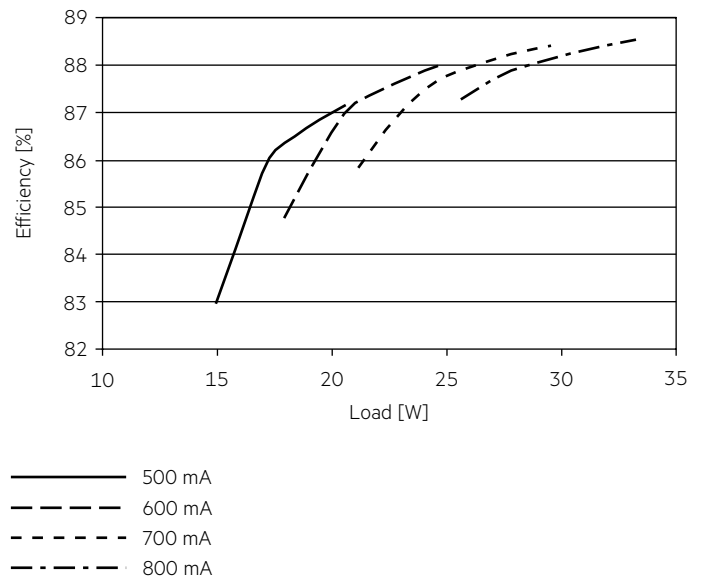

##### 4.2 Power factor vs load

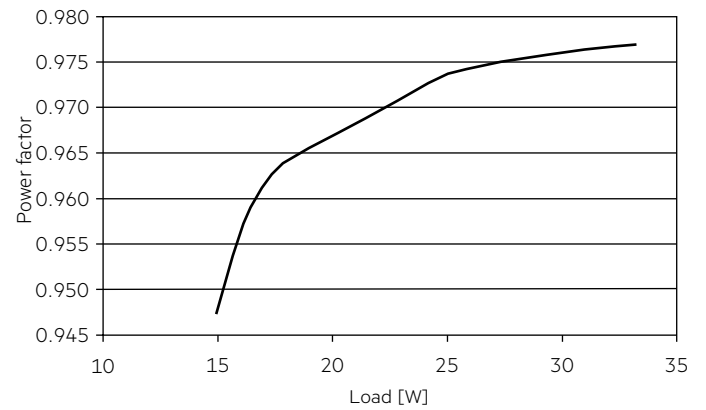

##### 4.3 THD vs load

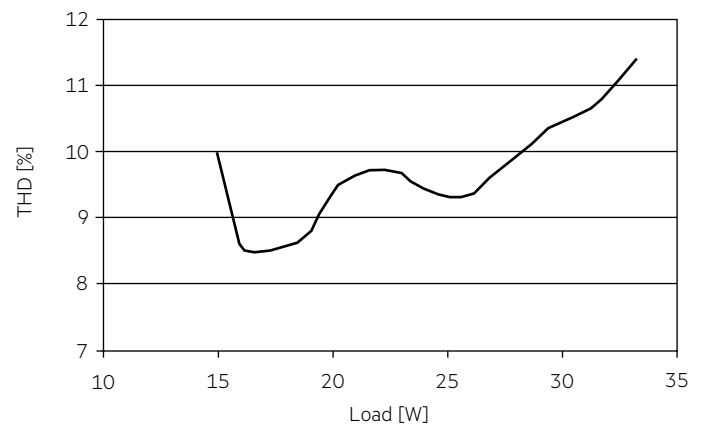

#### 4.4 Maximum loading of automatic circuit breakers in relation to inrush current

Automatic circuit breaker type	C10	C13	C16	C20	B10	B13	B16	B20	Inrush current	
Installation Ø	1.5 mm <sup>2</sup>	1.5 mm <sup>2</sup>	2.5 mm <sup>2</sup>	2.5 mm <sup>2</sup>	1.5 mm <sup>2</sup>	1.5 mm <sup>2</sup>	2.5 mm <sup>2</sup>	2.5 mm <sup>2</sup>	I <sub>max</sub>	Time
<b>LC 34/500-800/42 flexC T SNC4</b>	39	49	61	79	24	30	37	48	16.7 A	160 µs

These are max. values calculated out of inrush current! Please consider not to exceed the maximum rated continuous current of the circuit breaker. Calculation uses typical values from ABB series S200 as a reference. Actual values may differ due to used circuit breaker types and installation environment.

#### 4.5 Harmonic distortion in the mains supply (at 230 V / 50 Hz and full load) in %

	THD	3.	5.	7.	9.	11.
<b>LC 34/500-800/42 flexC T SNC4</b>	< 12	< 15	< 10	< 7	< 5	< 3

## 5. Functions

### 5.1 Short-circuit behaviour

In case of a short circuit on the secondary side (LED) the LED driver switches off. After elimination of the short-circuit fault the LED driver will recover automatically.

### 5.2 No-load operation

The LED driver works in burst working mode to provide a constant output voltage regulation which allows the application to be able to work safely when LED string opens due to a failure.

### 5.3 Overload protection

If the maximum load is exceeded by a defined internal limit, the LED driver will protect itself and LED may flicker. After elimination of the overload the nominal operation will recover automatically.

## 6. Miscellaneous

### 6.1 Insulation and electric strength testing of luminaires

Electronic devices can be damaged by high voltage. This has to be considered during the routine testing of the luminaires in production.

According to IEC 60598-1 Annex Q (informative only!) or ENEC 303-Annex A, each luminaire should be submitted to an insulation test with 500 V<sub>DC</sub> for 1 second. This test voltage should be connected between the interconnected phase and neutral terminals and the earth terminal. The insulation resistance must be at least 2 MΩ.

As an alternative, IEC 60598-1 Annex Q describes a test of the electrical strength with 1500 V<sub>AC</sub> (or 1.414 x 1500 V<sub>DC</sub>). To avoid damage to the electronic devices this test must not be conducted.

### 6.2 Conditions of use and storage

Humidity: 5% up to max. 95%,  
not condensed  
(max. 56 days/year at 95%)

Storage temperature: -25 °C up to max. +80 °C

The devices have to be within the specified temperature range (t<sub>a</sub>) before they can be operated.

### 6.3 Maximum number of switching cycles

All LED driver are tested with 50,000 switching cycles.

### 6.4 Additional information

Additional technical information at [www.tridonic.com](http://www.tridonic.com) → Technical Data

Lifetime declarations are informative and represent no warranty claim. No warranty if device was opened.