

Driver LC 28W 450–650mA 42V stepDIM R SNC3

essence round series

**Product description**

- _ LED Constant current LED driver for luminaire installation
- _ LED driver with sensor (included in delivery).
- _ For luminaires of protection class II
- _ Selectable fixed output current 450, 500, 600 and 650 mA (pre-selected current 450 mA)
- _ Max. output power 28 W
- _ Up to 87 % efficiency
- _ Nominal lifetime up to 100,000 h
- _ 5 years guarantee (conditions at <https://www.tridonic.com/en/int/services/manufacturer-guarantee-conditions>)

Housing properties

- _ Casing: polycarbonate, white
- _ Type of protection IP20

Functions

- _ Overload protection
- _ Overtemperature protection
- _ Short-circuit protection
- _ No-load protection

Typical applications

- _ For spot light, track light and wall light in retail and hospitality application

Website

<http://www.tridonic.com/28006369>

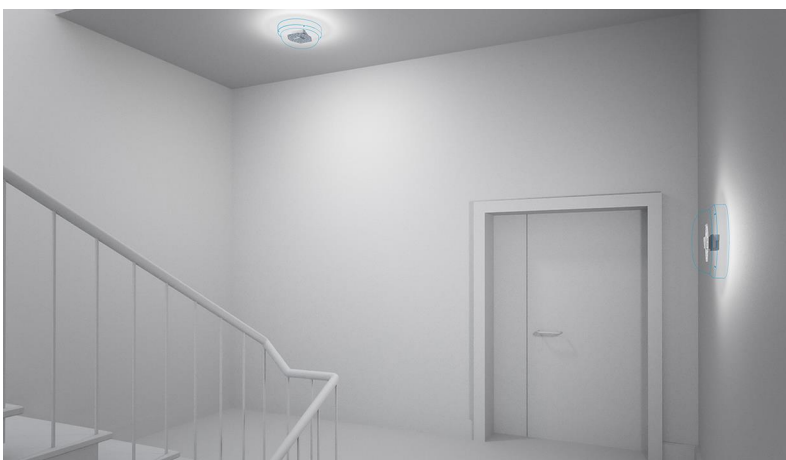

Linear



High bay



Decorative



Downlights



Spotlights



Free-standing



Area



Floor | Wall



Street

Driver LC 28W 450–650mA 42V stepDIM R SNC3

essence round series

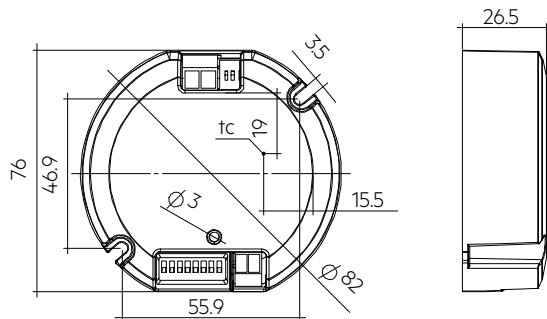

Ordering data

Type	Article number	Packaging, carton	Packaging, pallet	Weight per pc.
LC 28/450-650/42 stepDIM R SNC3	28006369	24 pc(s).	2,592 pc(s).	0.094 kg

Technical data

Rated supply voltage	220 – 240 V
AC voltage range	198 – 264 V
Max. input current (at 230 V, 50 Hz, full load)	0.16 A
Leakage current (at 230 V, 50 Hz, full load)	< 500 µA
Mains frequency	50 / 60 Hz
Overvoltage protection	320 V AC, 2 h
Typ. power consumption on stand-by	< 0.5 W
Max. output power	27 W
Output power range	14 – 27 W
Typ. efficiency (at 230 V, 50 Hz, full load) ^{①②}	87 %
λ over full operating range (max.)	0.9C
λ over full operating range (min.)	0.75C
Output current tolerance ^③	± 5 %
Max. output voltage (U-OUT)	55 V
THD (at 230 V, 50 Hz, full load) ^④	< 12 %
Max. peak output current at full load ^①	717 mA
Output LF current ripple (< 120 Hz) at full load	± 5 %
Output P_ST_LM (at full load)	≤ 1
Output SVM (at full load)	≤ 0.4
Starting time (at 230 V, 50 Hz, full load)	< 1.5 s
Turn off time (at 230 V, 50 Hz, full load)	≤ 0.1 s
Hold on time at power failure (output)	< 0.5 s
Frequency	5.8 GHz (± 75 MHz)
Detection angle	30 – 150°
Transmission power	< 0.2 mW
Max. detection area	ø 6 m
Max. mounting height	5 m
Ambient temperature t _a (at lifetime 50,000 h)	50 °C
Storage temperature t _s	-30 ... +85 °C
Mains burst capability	1 kV
Mains surge capability (between L - N)	1 kV
Mains surge capability (between L/N - PE)	2 kV
Surge voltage at output side (against PE)	0.5 kV
Lifetime	up to 100,000 h
Guarantee (conditions at www.tridonic.com)	5 Year(s)
Dimensions L x W x H	82 x 76 x 26.5 mm

Approval marks



Standards

EN 55015, EN 61000-3-2, EN 61000-3-3, EN 61347-1, EN 61347-2-13, EN 61547, EN 62384

Specific technical data

Type	Output current ^①	Min. output voltage	Max. output voltage	Max. output power	Typ. power consumption (at 230 V, 50 Hz, full load)	Typ. current consumption (at 230 V, 50 Hz, full load)	tc point max.	Ambient temperature T _a	I-out select
LC 28/450-650/42 stepDIM R SNC3	450 mA	30 V	42 V	19 W	22.2 W	100 mA	80 °C	-20 ... +50 °C	1=off / 2=off
LC 28/450-650/42 stepDIM R SNC3	500 mA	30 V	42 V	21 W	24.7 W	120 mA	80 °C	-20 ... +50 °C	1=on / 2=off
LC 28/450-650/42 stepDIM R SNC3	600 mA	30 V	42 V	25 W	29.6 W	140 mA	85 °C	-20 ... +50 °C	1=off / 2=on
LC 28/450-650/42 stepDIM R SNC3	650 mA	30 V	42 V	27 W	31.7 W	160 mA	85 °C	-20 ... +50 °C	1=on / 2=on

① Test result at 600 mA.

② Efficiency is with the supplied sensor, not only the LED-driver.

③ Test result at 25 °C.

④ Output current is mean value.

1. Standards

EN 55015
 EN 61000-3-2
 EN 61000-3-3
 EN 61347-1
 EN 61347-2-13
 EN 61547
 EN 62384

1.1 Glow-wire test

according to EN 61347-1 with increased temperature of 850 °C passed.

2. Thermal details and lifetime

2.1 Expected lifetime

Expected lifetime				
Type	ta	25 °C	35 °C	50 °C
450 - 500 mA	tc	55 °C ^①	65 °C ^①	80 °C ^①
	Lifetime	> 100,000 h	> 100,000 h	50,000 h
LC 28/450-650/42 stepDIM R SNCS 600 - 650 mA	tc	60 °C ^①	70 °C ^①	85 °C ^①
	Lifetime	100,000 h	100,000 h	50,000 h

^① Test result at max. output voltage.

The LED drivers are designed for a lifetime stated above under reference conditions and with a failure probability of less than 10 %.

The relation of tc to ta temperature depends also on the luminaire design. If the measured tc temperature is approx. 5 K below tc max., ta temperature should be checked and eventually critical components (e.g. ELCAP) measured. Detailed information on request.

3. Installation / wiring

3.1 Circuit diagram

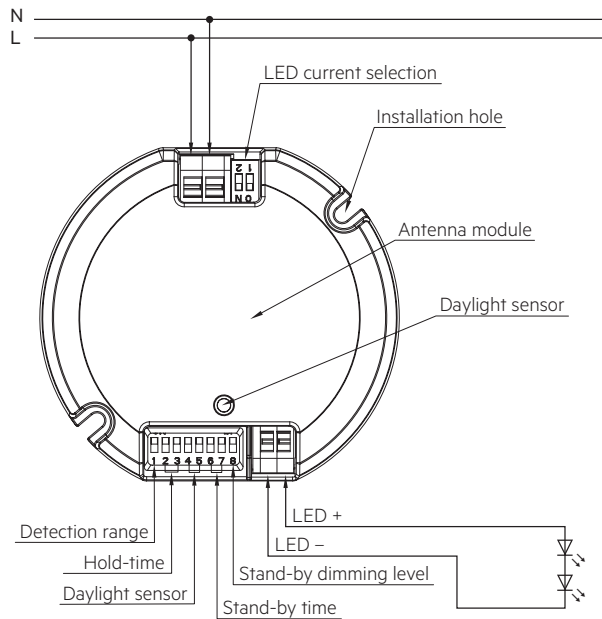

3.2 Adjustable dip switch setting

Setting the detection area (1. sensitivity)

1	Sensitivity
●	100 %
○	50 %



Sensitivity can be adjusted by selecting the combination on the DIP switches for different application.

Setting the hold time (2. and 3. hold time)

2	3	Hold time
●	●	5 s
●	○	90 s
○	●	3 min
○	○	10 min



Hold-time refers to the time period that the light remains 100% on if no more movement is detected.

Setting the daylight threshold (4. and 5. daylight threshold)

4	5	Daylight threshold
●	●	disable
●	○	50 Lux
○	●	10 Lux
○	○	2 Lux



Different daylight threshold can be preset on DIP switches. Light will always turn on upon movement if daylight sensor is disabled.

Setting the second-order delay (6. and 7. stand-by time)

6	7	Stand-by time
●	●	0 s
●	○	10 s
○	●	10 min
○	○	+∞

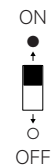

This is the time period that the light remains at a low level before it is completely turned off.

Setting the standby dimming (8. stand-by dimming level)

8	Stand-by dimming level
●	10 %
○	30 %



Light can be dimmed to different levels after hold-time.

3.3 Wiring type and cross section

Input

For wiring use stranded wire with ferrules or solid wire from 0.75–1.5 mm². Strip 7–8 mm of insulation from the cables to ensure perfect operation of the push-wire terminals.

Use one wire for each terminal connector only.

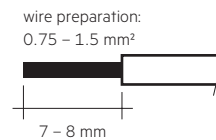

Output

For wiring use stranded wire with ferrules or solid wire from 0.5–1.5 mm². Strip 7–8 mm of insulation from the cables to ensure perfect operation of the push-wire terminals.

Use one wire for each terminal connector only.

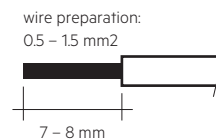

3.4 Release of the wiring

Press down the "push button" and remove the cable from front.

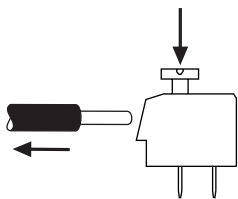

3.5 Wiring guidelines

- All connections must be kept as short as possible to ensure good EMI behaviour.
- Mains leads should be kept apart from LED driver and other leads (ideally 5 – 10 cm distance)
- Max. length of output wires is 2 m.
- The secondary wires (LED module) should be routed in parallel to ensure good EMC performance.
- Secondary switching is not permitted.
- Incorrect wiring can damage LED modules.
- To avoid damage of the Driver, the wiring must be protected against short circuits to earth (sharp edged metal parts, metal cable clips, louver, etc.).

3.6 Replace LED module

1. Mains off
2. Remove LED module
3. Wait for 30 seconds
4. Connect LED module again

Hot plug-in or secondary switching of LEDs is not permitted and may cause a very high current to the LEDs.

3.7 Detection pattern

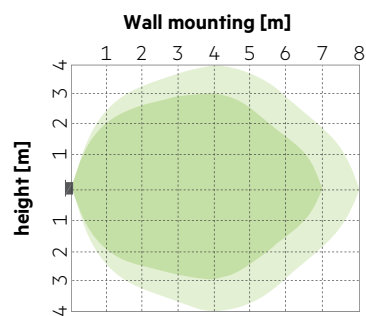
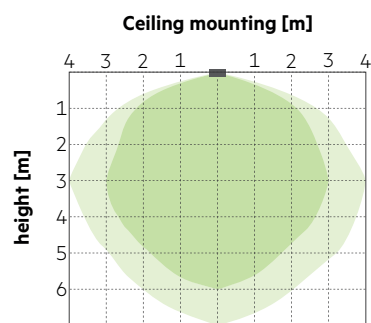

- high sensitivity area
- low sensitivity area

3.8 Assembly

Sensor module
Antenna module
Do not cover the converter surface with conductive material, like metal sheets.
Do not cover light sensing element with untransparent material.



3.9 Application examples

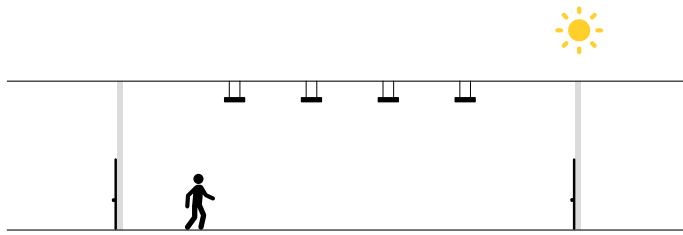

The light keeps off during daytime even when movement is detected. (Ambient lux level is above preset daylight threshold)

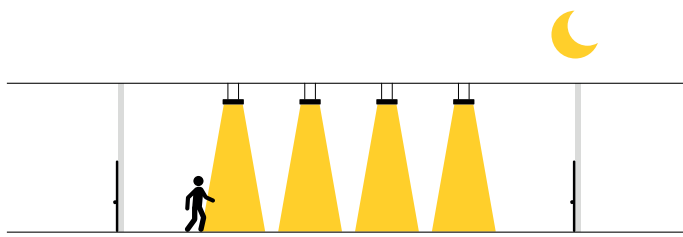

With movement and insufficient ambient lux level, the light is triggered on 100% by the detector.

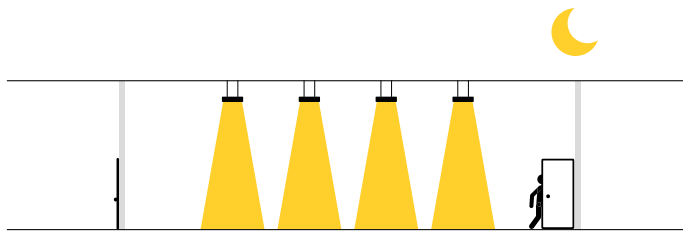

If there is no more movement, the light dims to stand-by dimming level after hold-time.

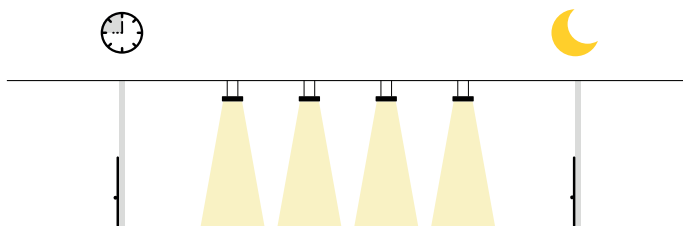

The light turns off automatically after stand-by time.

3.10 Current setting



Set the current by DIP switch after mains off. Use of DIP switch only after mains off.

450 mA: Switch 1 = Off, Switch 2 = Off

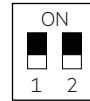

500 mA: Switch 1 = On, Switch 2 = Off



600 mA: Switch 1 = Off, Switch 2 = On



650 mA: Switch 1 = On, Switch 2 = On

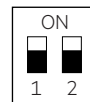

3.11 Passing by the sensor

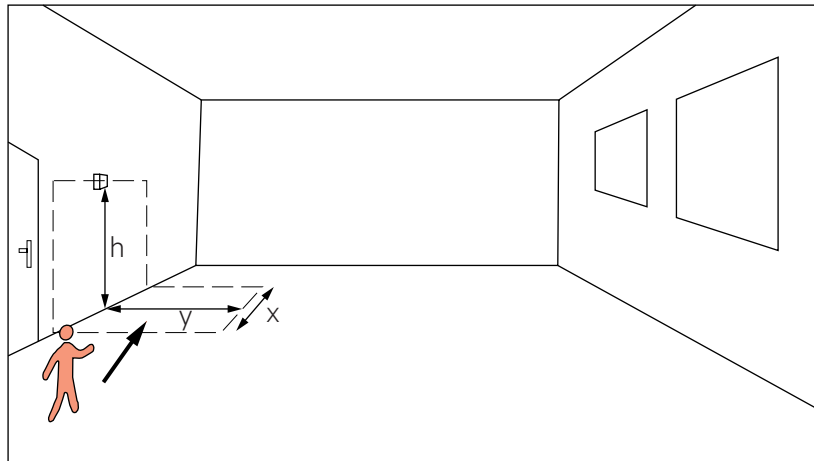
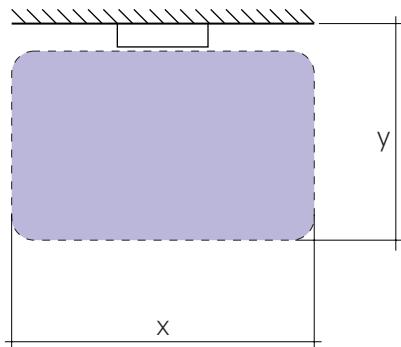

x	y	h	sensitivity
6.0 m	6.0 m	1.8 m	100 %
4.0 m	5.0 m	1.8 m	50 %

3.12 Towards the sensor

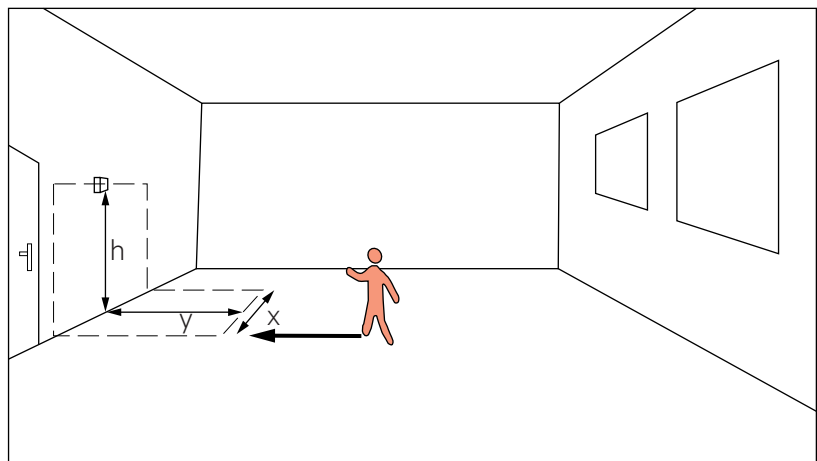
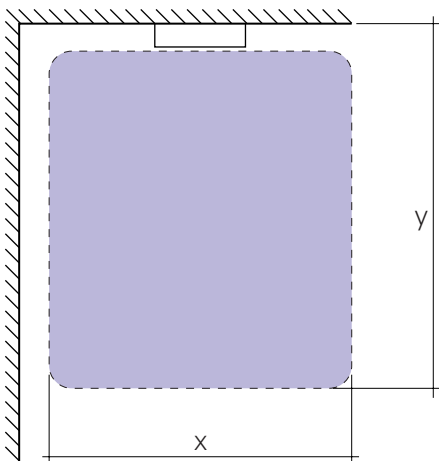

x	y	h	sensitivity
6.0 m	8.0 m	1.8 m	100 %
4.0 m	5.0 m	1.8 m	50 %

3.13 Ceiling mounted

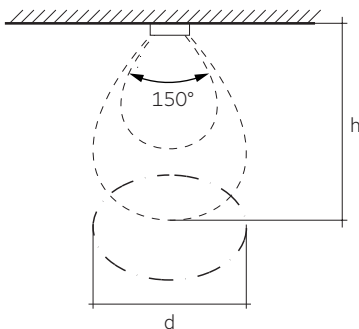

x	d	
	100 %	50 %
2.0 m	5.0 m	2.5 m
2.5 m	5.5 m	3.0 m
3.0 m	6.0 m	3.0 m
3.5 m	5.5 m	3.0 m
4.0 m	5.0 m	2.5 m
4.5 m	4.0 m	2.0 m
5.0 m	3.0 m	1.5 m

The table shows the diameter of the detection cone as a function of height at maximum detection area without considering objects in the room. Stationary objects (walls, tables, floor-standing luminaires, etc.) located in the direct view of the sensor change the characteristics of the detection area. The mentioned values are typical minimum values. Depending on the environment and application the detection area may increase.

4. Electrical values

4.1 Diagrams

4.1.1 Efficiency vs load

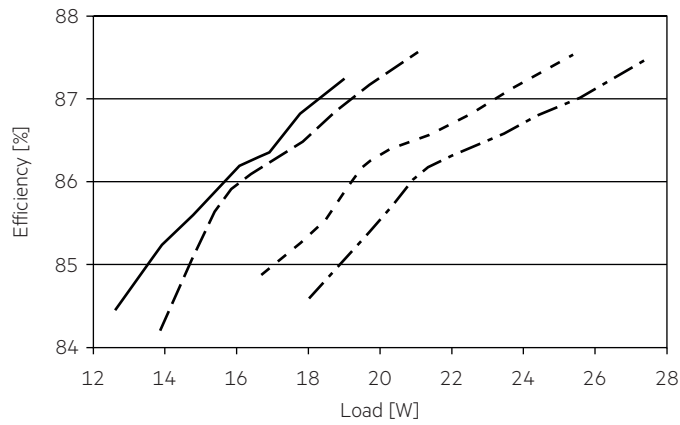

Efficiency is with the supplied sensor, not only the LED-driver.

4.1.3 THD vs load

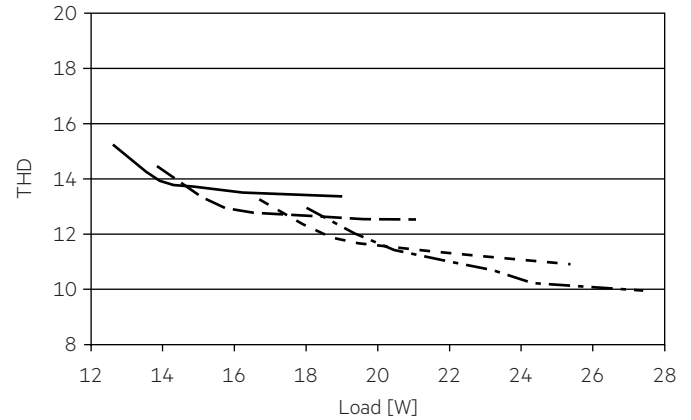

4.1.2 Power factor vs load

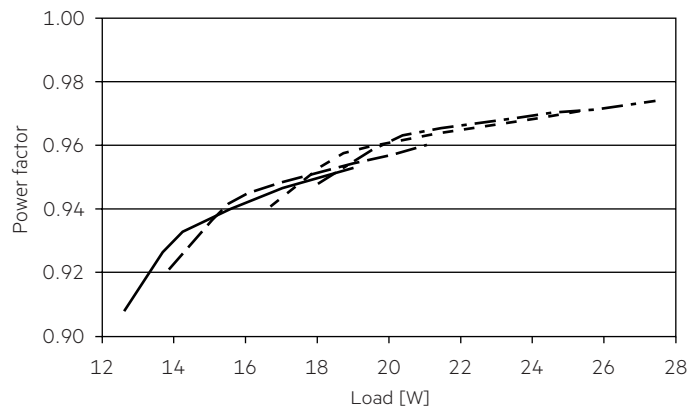

— 450 mA
 - - - 500 mA
 - - - 600 mA
 - - - 650 mA

4.2 Maximum loading of automatic circuit breakers in relation to inrush current

Automatic circuit breaker type	C10	C13	C16	C20	B10	B13	B16	B20	Inrush current
Installation Ø	1.5 mm ²	1.5 mm ²	1.5 mm ²	2.5 mm ²	1.5 mm ²	1.5 mm ²	1.5 mm ²	2.5 mm ²	I _{max} Time
LC 28/450-650/42 stepDIM R SNC3	62	81	100	125	56	73	90	112	9,56 A 151 µs

These are max. values calculated out of inrush current! Please consider not to exceed the maximum rated continuous current of the circuit breaker. Calculation uses typical values from ABB series S200 as a reference. Actual values may differ due to used circuit breaker types and installation environment.

4.3 Harmonic distortion in the mains supply (at 230 V / 50 Hz and full load) in %

	THD	3.	5.	7.	9.	11.
LC 28/450-650/42 stepDIM R SNC3	< 12	< 10	< 8	< 7	< 5	< 3

5. Functions

5.1 Short-circuit behaviour

In case of a short circuit on the secondary side (LED) the LED driver switches off. After elimination of the short-circuit fault the LED driver will recover automatically.

5.2 No-load operation

The LED driver works in burst working mode to provide a constant output voltage regulation which allows the application to be able to work safely when LED string opens due to a failure.

5.3 Overload protection

If the maximum load is exceeded by a defined internal limit, the LED driver will protect itself and the output current will decrease till LED flicker. After elimination of the overload, the nominal operation is restored automatically.

5.4 Overtemperature protection

The controlgear is protected against temporary thermal overheating. If the temperature limit is exceeded the controlgear will switch off. It restarts automatically.

The temperature protection is activated typically 10 °C above T_c max.

6. Miscellaneous

6.1 Insulation and electric strength testing of luminaires

Electronic devices can be damaged by high voltage. This has to be considered during the routine testing of the luminaires in production.

According to IEC 60598-1 Annex Q (informative only!) or ENEC 303-Annex A, each luminaire should be submitted to an insulation test with 500 V_{DC} for 1 second. This test voltage should be connected between the interconnected phase and neutral terminals and the earth terminal. The insulation resistance must be at least 2 MΩ.

As an alternative, IEC 60598-1 Annex Q describes a test of the electrical strength with 1500 V_{AC} (or 1.414 x 1500 V_{DC}). To avoid damage to the electronic devices this test must not be conducted.

6.2 Conditions of use and storage

Humidity: 5 % up to max. 95 %,
not condensed
(max. 56 days/year at 95 %)

Storage temperature: -30 °C up to max. +85 °C

The devices have to be within the specified temperature range (t_a) before they can be operated.

The LED driver is declared as inbuilt LED controlgear, meaning it is intended to be used within a luminaire enclosure.

If the product is used outside a luminaire, the installation must provide suitable protection for people and environment (e.g. in illuminated ceilings).

6.3 Maximum number of switching cycles

All LED driver are tested with 50,000 switching cycles.

6.4 Additional information

Additional technical information at www.tridonic.com → Technical Data

Lifetime declarations are informative and represent no warranty claim. No warranty if device was opened.