

Driver LC 25W 600mA fixC T SNC

essence in-track series (1-phase system)



Black (RAL 9005)



White (RAL 9010)



Grey (RAL 7035)

Product description

- _ Constant current / in-track LED driver
- _ Accessory ACU ALU NIPPLE M10x1 for mounting the luminaire head included, but not pre-assembled
- _ Compatible 1-phase system in-tracks, see data sheet chapter 3.8
- _ For luminaires of protection class II
- _ Temperature protection as per EN 61347-2-13 C5e
- _ Max. output power 25 W
- _ Up to 88 % efficiency
- _ Nominal lifetime up to 100,000 h
- _ 5 years guarantee (conditions at <https://www.tridonic.com/en/int/services/manufacturer-guarantee-conditions>)

Housing properties

- _ Casing: polycarbonate, black, white or grey
- _ Type of protection IP20

Functions

- _ Overload protection
- _ Short-circuit protection
- _ No-load protection

Typical applications

- _ For spot light in retail and hospitality application

Website

<http://www.tridonic.com/28003361>



Linear



High bay



Decorative



Downlights



Spotlights



Free-standing



Area



Floor | Wall



Street

Driver LC 25W 600mA fixC T SNC

essence in-track series (1-phase system)

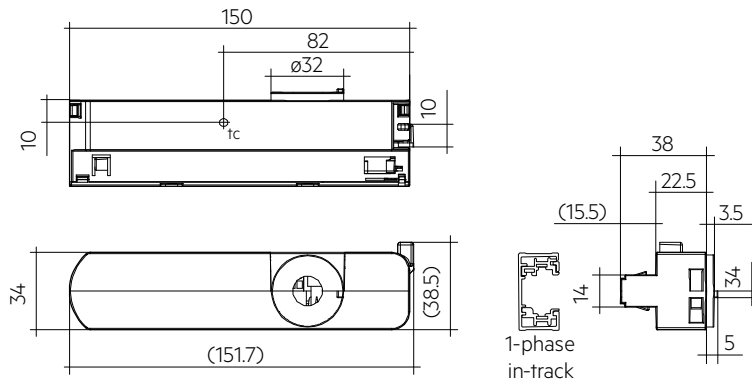
**Ordering data**

Type	Article number	Colour	Packaging, carton	Packaging, low volume	Weight per pc.
LC 25/600/42 fixC T-B SNC	28003361	Black	50 pc(s).	1,200 pc(s).	0.1 kg
LC 25/600/42 fixC T-W SNC	28003356	White	50 pc(s).	1,200 pc(s).	0.1 kg
LC 25/600/42 fixC T-G SNC	28003366	Grey	50 pc(s).	1,200 pc(s).	0.1 kg

Technical data

Rated supply voltage	220 – 240 V
AC voltage range	198 – 264 V
Max. input current (at 230 V, 50 Hz, full load)	0.15 A
Leakage current (at 230 V, 50 Hz, full load)	< 50 μ A
Mains frequency	50 / 60 Hz
Overvoltage protection	320 V AC, 48 h
Max. input power	30 W
Typ. power consumption (at 230 V, 50 Hz, full load)	28.6 W
Min. output power	18 W
Max. output power	25 W
Typ. efficiency (at 230 V, 50 Hz, full load)	88 %
λ (at 230 V, 50 Hz, full load)	0.95
Output current tolerance ^①	\pm 7.5 %
Max. output current peak ^②	677 mA
Max. output voltage (U-OUT)	50 V
THD (at 230 V, 50 Hz, full load)	< 15 %
Output LF current ripple (< 120 Hz)	\pm 5 %
Output P_ST_LM (at full load)	\leq 1
Output SVM (at full load)	\leq 0.4
Starting time (at 230 V, 50 Hz, full load)	< 0.5 s
Turn off time (at 230 V, 50 Hz, full load)	\leq 0.7 s
Hold on time at power failure (output)	0 s
Ambient temperature t_a (at lifetime 100,000 h)	35 °C
Storage temperature t_s	-40 ... +80 °C
Mains surge capability (between L - N)	1 kV
Mains surge capability (between L/N - PE)	2 kV
Surge voltage at output side (against PE)	< 0.5 kV
Lifetime	up to 100,000 h
Guarantee (conditions at www.tridonic.com)	5 Year(s)
Dimensions L x W x H	150 x 34 x 38 mm

Approval marksIP20 SELV       **Standards**

EN 55015, EN 61000-3-2, EN 61000-3-3, EN 61347-1, EN 61347-2-13, EN 61547, EN 61000-4-4, EN 61000-4-5

Specific technical data

Type	Output current ^①	Min. output voltage	Max. output voltage	Max. output power	Typ. power consumption (at 230 V, 50 Hz, full load)	Typ. current consumption (at 230 V, 50 Hz, full load)	tc point max.	Ambient temperature ta
LC 25/600/42 fixC T-B SNC	600 mA	30 V	42 V	25 W	28.6 W	150 mA	78 °C	-20 ... +35 °C
LC 25/600/42 fixC T-W SNC	600 mA	30 V	42 V	25 W	28.6 W	150 mA	78 °C	-20 ... +35 °C
LC 25/600/42 fixC T-G SNC	600 mA	30 V	42 V	25 W	28.6 W	150 mA	78 °C	-20 ... +35 °C

① Output current is mean value.

② Test result at 25 °C.

1. Standards

EN 55015
 EN 61000-3-2
 EN 61000-3-3
 EN 61347-1
 EN 61347-2-13
 EN 61547
 EN 61000-4-4
 EN 61000-4-5

1.1 Glow-wire test

according to EN 61347-1 with increased temperature of 850 °C passed.

2. Thermal details and lifetime

2.1 Expected lifetime

Expected lifetime

Type	ta	30 °C	35 °C
LC 25/600/42 fixC T SNC	Lifetime	> 125,000 h	90,000 h

^① Test result at max. output voltage.

The LED drivers are designed for a lifetime stated above under reference conditions and with a failure probability of less than 10 %.

Temperatures were measured with Tracktype PRO-310 from manufacturer powergear. Temperatures can deviate with tracks from other manufacturers.

3. Installation / wiring

3.1 Circuit diagram

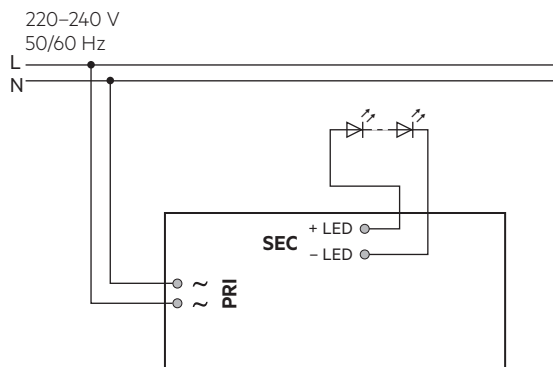

3.2 Wiring type and cross section

The wiring can be in stranded wires with ferrules or solid with a cross section of 0.5–1.5 mm². Strip 8.5–9.5 mm of insulation from the cables to ensure perfect operation of the push-wire terminals. Use one wire for each terminal connector only.

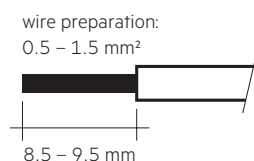

3.3 Release of the wiring

Press down the “push button” and remove the cable from front.

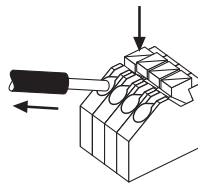

3.4 Fixing conditions

Dry, acidfree, oilfree, fatfree. It is not allowed to exceed the maximum ambient temperature (ta) stated on the device.

3.5 Wiring guidelines

- All connections must be kept as short as possible to ensure good EMI behaviour.
- Max. length of output wires is 20 cm.
- Secondary switching is not permitted.
- Incorrect wiring can damage LED modules.
- To avoid the damage of the Driver, the wiring must be protected against short circuits to earth (sharp edged metal parts, metal cable clips, louver, etc.).

3.6 Replace LED module

1. Mains off
2. Remove LED module
3. Wait for 10 seconds
4. Connect LED module again

Hot plug-in or secondary switching of LEDs is not permitted and may cause a very high current to the LEDs.

3.7 Mounting luminaire

Max. allowed weight of complete luminaire: 5 kg (50 N)

3.8 Compatible 1-phase tracks

Subject to be changed without notice.

Manufacturer	Type	Casing colour
powergear	PRO-0310-W	white (RAL 9010)
powergear	PRO-0310-S	silver (RAL7040)
powergear	PRO-0310-B	black (RAL9011)
SAL	STR4800/1 WH	1M TRACK, white
SAL	STR4800/1 BK	1M TRACK, black
SAL	STR4800/2 WH	2M TRACK, white
SAL	STR4800/2 BK	2M TRACK, black

Tests have been done with in-tracks taken from the market in the first half of 2018.



Tridonic has no control or responsibility on any future or past possible changes made by different manufactures that could affect the compatibility between tracks and adapters.

3.9 Adapter mounting into the track

Insert the adapter into the track, so that the copper connection (B) in the adaptor matches the groove (A) in the track. Rotate of about 90° the lever of the cam (C) until it reaches the locking position. To open rotate the lever the opposite direction.

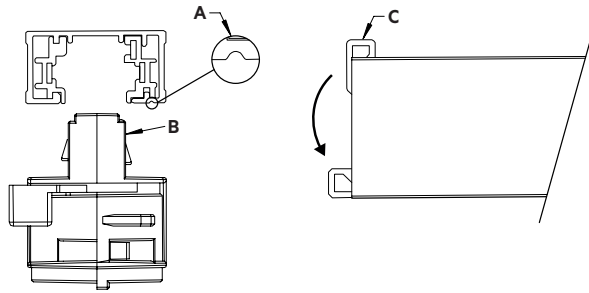

3.10 Nipple installation

1. Nipple is locked in the rod.

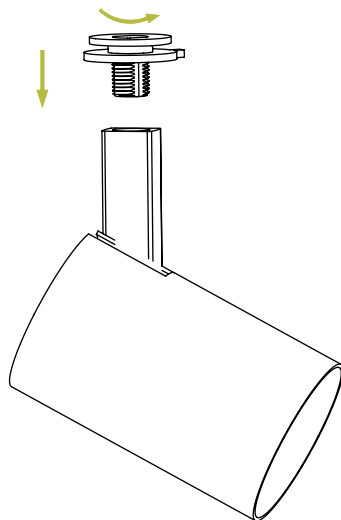

2. Install the nipple into driver.

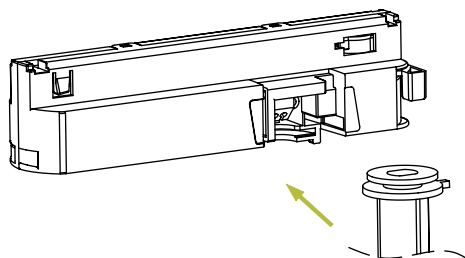

3. Assemble the side lock cover.

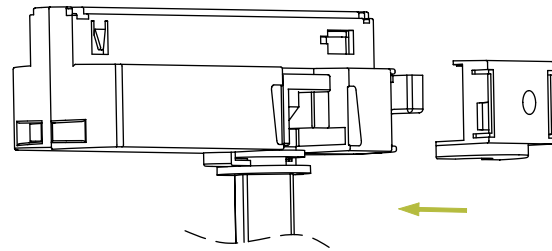

4. Lock screw.

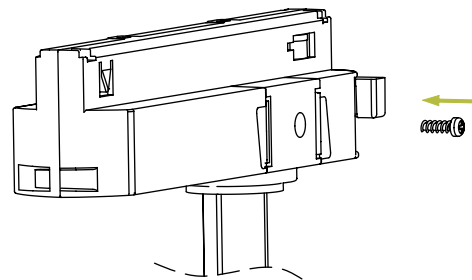

5. Installation is finished.

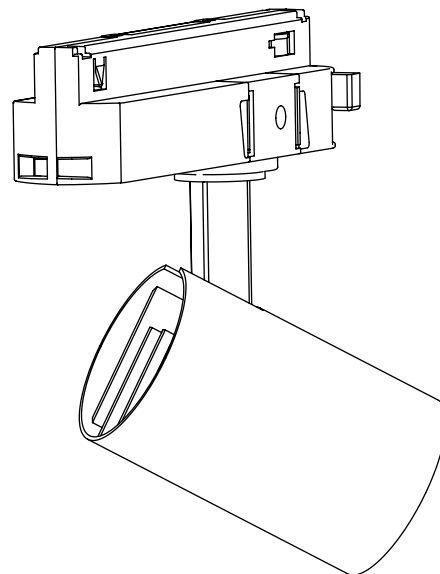

4. Electrical values

4.1 Efficiency vs load

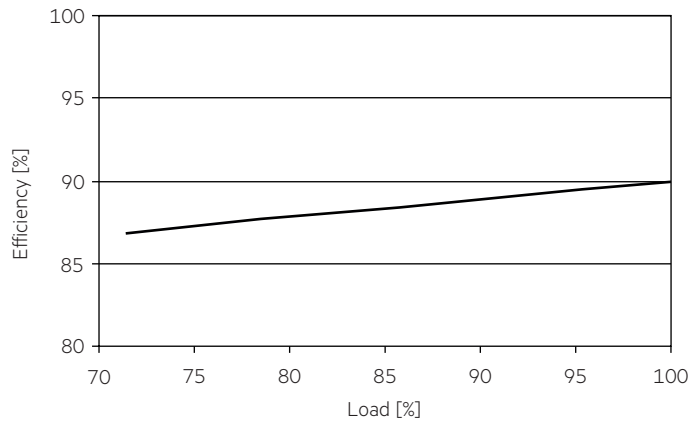

4.4 Input current vs load

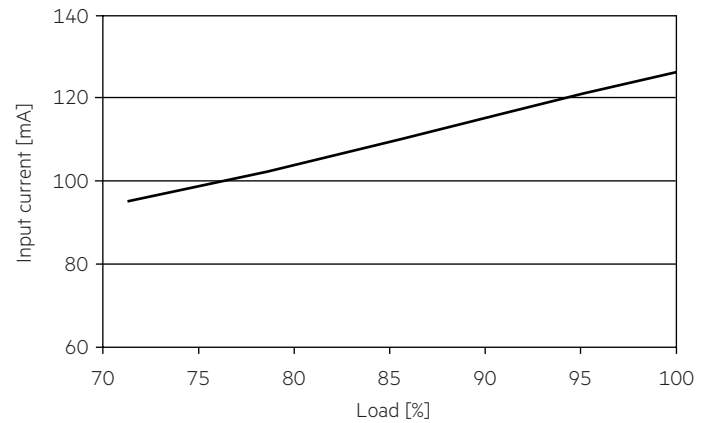

4.2 Power factor vs load

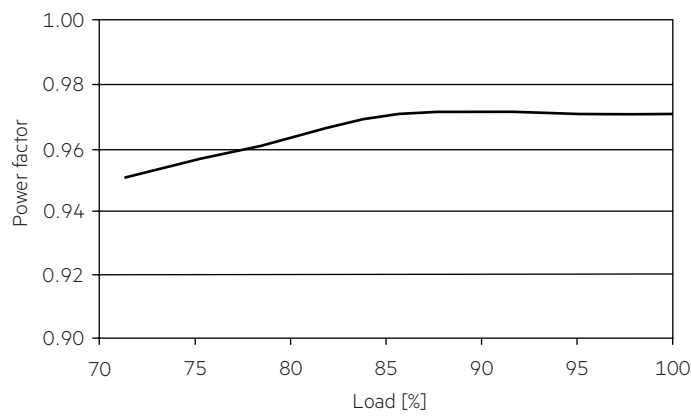

4.5 THD vs load

THD without harmonic < 5 mA (0.6 %) of the input current:

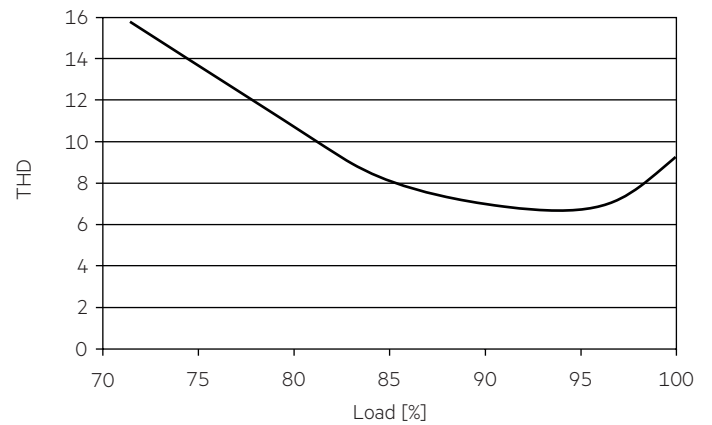

4.3 Input power vs load

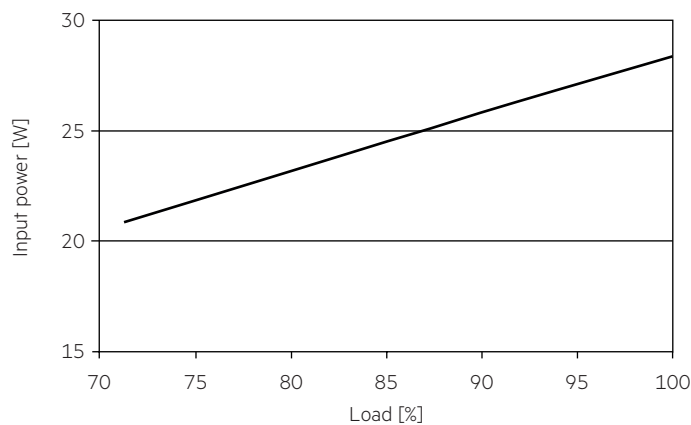

4.6 Maximum loading of automatic circuit breakers in relation to inrush current

Automatic circuit breaker type	C10	C13	C16	C20	B10	B13	B16	B20	Inrush current	
Installation Ø	1.5 mm ²	1.5 mm ²	2.5 mm ²	2.5 mm ²	1.5 mm ²	1.5 mm ²	2.5 mm ²	2.5 mm ²	I _{max}	Time
LC 25/600/42 fixC T SNC	68	85	101	118	41	51	61	71	13 A	129 µs

These are max. values calculated out of inrush current! Please consider not to exceed the maximum rated continuous current of the circuit breaker. Calculation uses typical values from ABB series S200 as a reference. Actual values may differ due to used circuit breaker types and installation environment.

4.7 Harmonic distortion in the mains supply (at 230 V / 50 Hz and full load) in %

	THD	3.	5.	7.	9.	11.
LC 25/600/42 fixC T SNC	< 15	< 12	< 7	< 5	< 4	< 3

Acc. to 6100-3-2. Harmonics < 5 mA or < 0.6 % (whatever is greater) of the input current are not considered for calculation of THD.

5. Functions

5.1 Short-circuit behaviour

In case of a short circuit on the secondary side (LED) the LED driver switches off. After elimination of the short-circuit fault the LED driver will recover automatically.

5.2 No-load operation

The LED driver works in burst working mode to provide a constant output voltage regulation which allows the application to be able to work safely when LED string opens due to a failure.

5.3 Overload protection

If the maximum load is exceeded by a defined internal limit, the LED driver will protect itself and LED may flicker. After elimination of the overload the nominal operation will recover automatically.

6. Miscellaneous

6.1 Insulation and electric strength testing of luminaires

Electronic devices can be damaged by high voltage. This has to be considered during the routine testing of the luminaires in production.

According to IEC 60598-1 Annex Q (informative only!) or ENEC 303-Annex A, each luminaire should be submitted to an insulation test with 500 V_{DC} for 1 second. This test voltage should be connected between the interconnected phase and neutral terminals and the earth terminal. The insulation resistance must be at least 2 MΩ.

As an alternative, IEC 60598-1 Annex Q describes a test of the electrical strength with 1500 V_{AC} (or 1.414 x 1500 V_{DC}). To avoid damage to the electronic devices this test must not be conducted.

6.2 Conditions of use and storage

Humidity: 5 % up to max. 95 %, not condensed (max. 56 days/year at 95 %)

Storage temperature: -40 °C up to max. +80 °C

The devices have to be within the specified temperature range (t_a) before they can be operated.

6.3 Maximum number of switching cycles

All LED driver are tested with 50,000 switching cycles.

6.4 Additional information

Additional technical information at www.tridonic.com → Technical Data

Lifetime declarations are informative and represent no warranty claim. No warranty if device was opened.