

Driver LCU 48V 150W DC-STR DIM Ip
Dimming



Product description

- _ Dimmable DC-String constant voltage built-in LED driver
- _ Compatible with other DC-String components
- _ DALI bridge with DC powerline communication (PLC)
- _ one4all interface (corridorFUNCTION, switchDIM, DALI, DSI)
- _ Max. output power 150 W
- _ Up to 92.5 % efficiency
- _ Nominal lifetime up to 50,000 h
- _ For luminaires of protection class I and protection class II
- _ Temperature protection as per EN 61347-2-13 C5e
- _ 5 years guarantee (conditions at <https://www.tridonic.com/en/int/services/manufacturer-guarantee-conditions>)

Housing properties

- _ Low profile metal casing with white cover
- _ Type of protection IP20

Functions

- _ DC-String compatible
- _ Intelligent Temperature Guard (overtemperature protection)
- _ Short-circuit protection
- _ Overload protection

Website

<http://www.tridonic.com/28001235>



Linear



High bay



Decorative



Downlights



Spotlights



Free-standing



Area



Floor | Wall



Street

Driver LCU 48V 150W DC-STR DIM Ip

Dimming

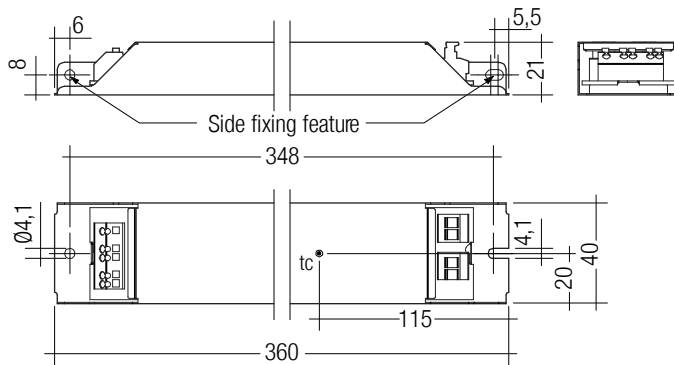

Ordering data

Type	Article number	Packaging, carton	Packaging, pallet	Weight per pc.
LCU 48V 150W DC-STR DIM Ip	28001235	20 pc(s).	600 pc(s).	0.354 kg

Technical data

Rated supply voltage	220 – 240 V
AC voltage range	198 – 264 V
Mains frequency	50 / 60 Hz
Typ. rated current (at 230 V, 50 Hz, full load)	710 mA
Leakage current (at 230 V, 50 Hz, full load)	< 500 μ A
Max. input power	162 W
Output power range (P _{rated})	1 – 150 W
Typ. efficiency (at 230 V, 50 Hz, full load)	92.5 %
λ over full operating range (max.)	0.99
λ over full operating range (min.)	0.26C
Typ. input current in no-load operation	69 mA
Typ. input power in no-load operation	3.6 W
In-rush current (peak / duration)	57.7 A / 202 μ s
THD (at 230 V, 50 Hz, full load)	< 5 %
Output voltage tolerance	-1 / +5 %
Output LF current ripple (< 120 Hz)	\pm 2 %
Max. output voltage (U-OUT)	50.5 V
Max. cable length secondary	Refer to data sheet
Mains surge capability (between L - N)	1 kV
Mains surge capability (between L/N - PE)	2 kV
Surge voltage at output side (against PE)	< 450 V
Ambient temperature t _a	-25 ... +50 °C
Max. casing temperature t _c	80 °C
Lifetime	up to 50,000 h
Guarantee (conditions at www.tridonic.com)	5 Year(s)
Dimensions L x W x H	360 x 40 x 21 mm

Approval marks



Standards

EN 55015, EN 61000-3-2, EN 61000-3-3, EN 61347-1, EN 61347-2-13, EN 62384, EN 61547

1. Standards

EN 55015
 EN 61000-3-2
 EN 61000-3-3
 EN 61347-1
 EN 61347-2-13
 EN 62384
 EN 61547

2. Thermal details and lifetime

2.1 Expected lifetime

Expected lifetime					
Type	ta	40 °C	45 °C	50 °C	Load
	tc	70 °C	75 °C	80 °C	75 – 100 %
		90,000 h	75,000 h	55,000 h	75 – 100 %
LCU 48V 150W DC-STR DIM Ip	Lifetime	>100,000 h	90,000 h	65,000 h	50 – 74 %
		>100,000 h	>100,000 h	85,000 h	25 – 49 %
		>100,000 h	>100,000 h	>100,000 h	0 – 24 %

The LED control gear is designed for a lifetime stated above under reference conditions and with a failure probability of less than 10 %.

The relation of tc to ta temperature depends also on the luminaire design.

If the measured tc temperature is approx. 5 K below tc max., ta temperature should be checked and eventually critical components (e.g. ELCAP) measured. Detailed information on request.

3. Installation / wiring

3.1 Circuit diagram

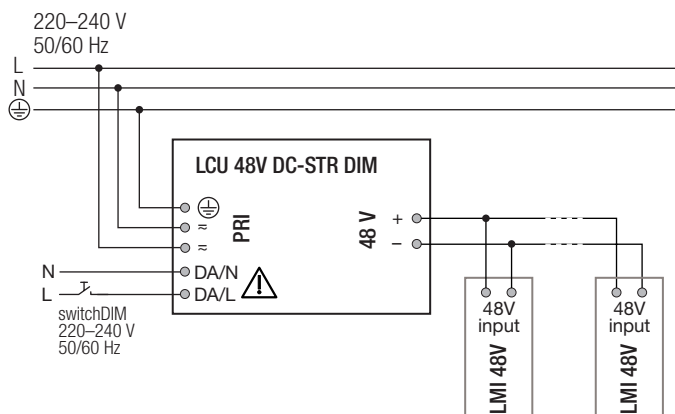
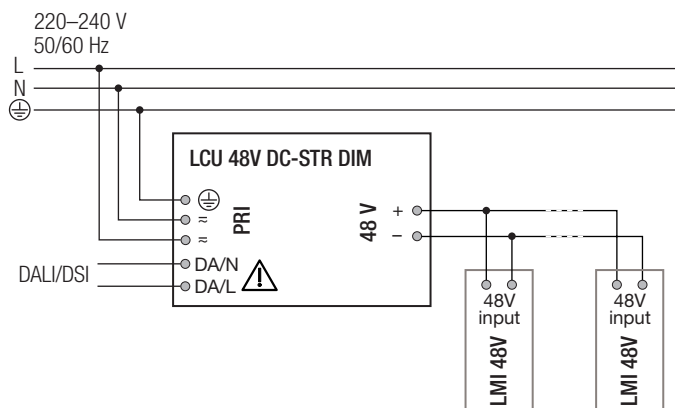

3.2 Mains supply wiring

For wiring use stranded wire with ferrules or solid wire from 0.2 – 1.5 mm².
 For perfect function of the push-wire terminals (WAGO 250) the strip length should be 8.5 – 9.5 mm.

DC power supply

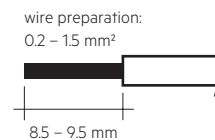

3.3 Output wiring (48 V bus)

For wiring use stranded wire with ferrules or solid wire from 0.2 – 2.5 mm².
 Strip 9 – 10 mm of insulation from the cables to ensure perfect operation of the push-wire terminals.

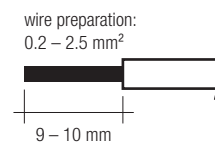

Use one wire for each terminal connector only.
 Use each strain relief channel for one cable only.

3.4 Loose wiring

Input terminal

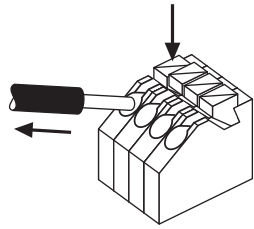

Output terminal

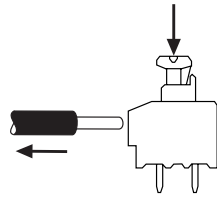

Release of the wiring

Press down the "push button" and remove the cable from front.

3.5 Wiring guidelines

- The 48 V cables should be run separately from the mains connections and mains cables to ensure good EMC conditions.
- The 48 V DC output wiring should be kept as short as possible to ensure good EMC.

When using an unshielded standard cable:

No additional measures are required for cable lengths of up to 5 meters.

The use of a ferrite is recommended for cable lengths between 5 and 20 meters (e.g. Wuerth 742 727 33).

When using a shielded cable with grounded shield:

No additional measures are required for cable lengths of up to 15 meters.

The use of a ferrite is recommended for cables longer than 15 meters (e.g. Wuerth 742 727 33).

- The max. secondary cable length is 30 m (60 m circuit) till beginning of a grounded metal track light. If track light is not grounded or made of plastic, cable length including track light is 30 m. Inside the track light cable length is limited by voltage drop that last LMI 48V in the track light is still supplied with minimum 46 V.
- Secondary switching is not permitted.
- To avoid damage of the Driver, the wiring must be protected against short circuits to earth (sharp edged metal parts, metal cable clips, louver, etc.).
- Additional systems or lines can compromise or disrupt the PLC communication in the DC string system. Therefore do not install any other systems or cables parallel to the DC string system cables.

3.6 Hot plug-in

Configured parameters of DC/DC-LED driver (LMI DIM) are not saved if they are unplugged.

For saving parameters a mains reset of the DC power supply is necessary. A delays of 5 seconds is also mandatory before turning power on afterwards. Maximum number of LMI LED drivers is limited by 20.

3.7 Function of the earth terminal ⊕

The device has to be earthed to fulfill EMI requirements.

3.8 Control terminals



There is a risk of electric shock when touching these terminals in case of failure.

4. Electrical values

4.1 Efficiency vs. load

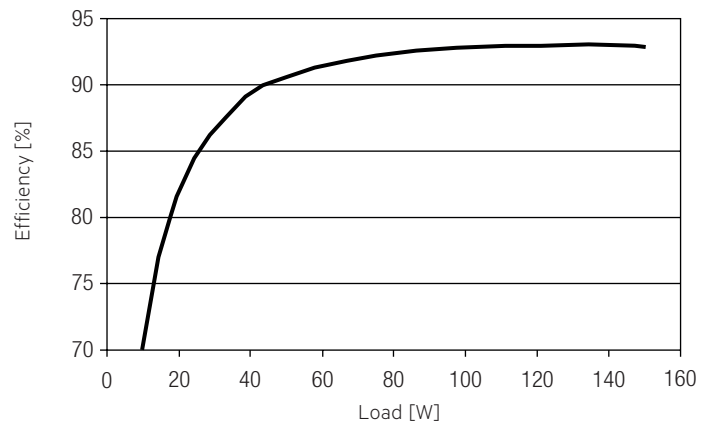

4.2 Power factor vs. Load

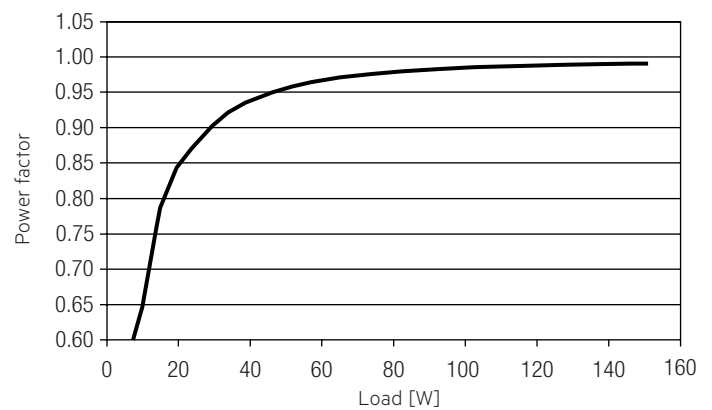

4.3 Input power vs. Load

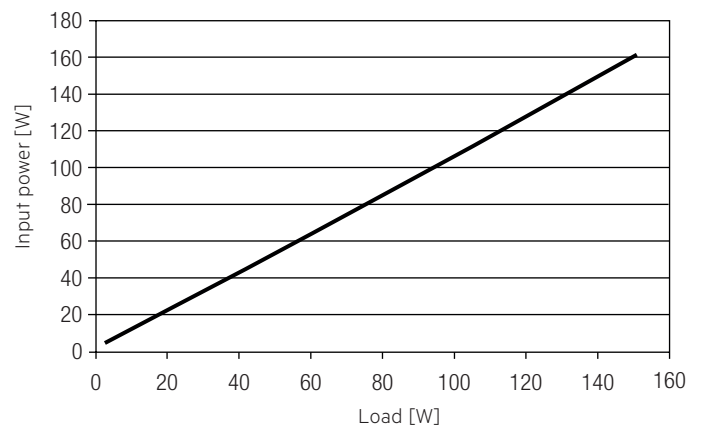

4.4 Input current vs. Load

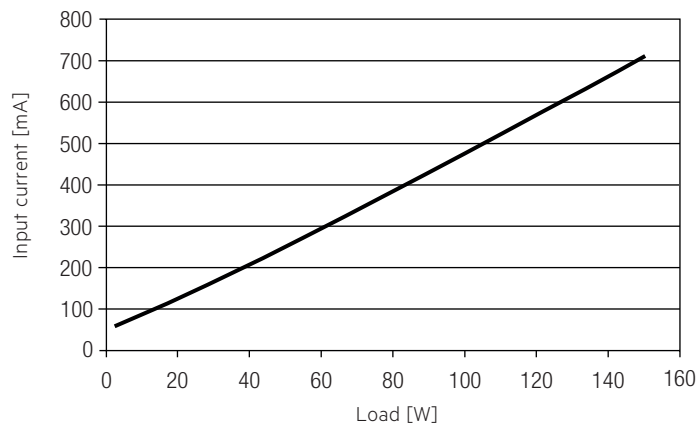

4.5 THD vs. Load

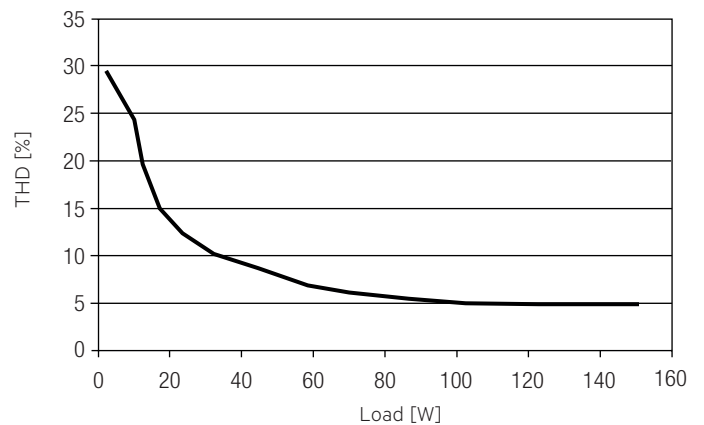

4.6 Maximum loading of automatic circuit breakers in relation to inrush current

Automatic circuit breaker type	C10	C13	C16	C20	B10	B13	B16	B20	Inrush current	
Installation Ø	1.5 mm ²	1.5 mm ²	2.5 mm ²	2.5 mm ²	1.5 mm ²	1.5 mm ²	2.5 mm ²	2.5 mm ²	I_{max}	time
LCU 48V 150W DC-STR DIM Ip	8	12	16	18	5	6	8	9	51 A	238 µs

These are max. values calculated out of inrush current! Please consider not to exceed the maximum rated continuous current of the circuit breaker.

Calculation uses typical values from ABB series S200 as a reference.

Actual values may differ due to used circuit breaker types and installation environment.

4.7 Harmonic distortion in the mains supply (at 230 V / 50 Hz and full load) in %

	THD	3.	5.	7.	9.	11.
LCU 48V 150W DC-STR DIM Ip	5	3	1	1	1	1

4.8 Dimming

Dimming range 70 mA to 100 % of nominal current

Digital control with:

Programmable parameter:

Minimum dimming level

Maximum dimming level

Default minimum = depending on nominal current level

Default maximum = 100 %

Dimming curve is adapted to the eye sensitiveness.

Dimming is realized by amplitude dimming.

4.9 Dimming characteristics

Digital dimming value

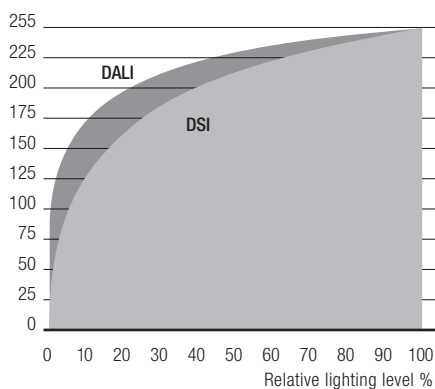

Dimming characteristics as seen by the human eye

5. Interfaces / communication

5.1 Control input (DA/N, DA/L)

Digital DALI signal or switchDIM can be wired on the same terminals (DA/N and DA/L).

The control input is non-polar for digital control signals (DALI, DSI). The control signal is not SELV. Control cable has to be installed in accordance to the requirements of low voltage installations.

Different functions depending on each module.

5.2 switchDIM

Integrated switchDIM function allows a direct connection of a pushbutton for dimming and switching.

Brief push (< 0.6 s) switches LED control gear ON and OFF. The dimm level is saved at power-down and restored at power-up.

When the pushbutton is held, LED modules are dimmed. After repush the LED modules are dimmed in the opposite direction.

In installations with LED control gears with different dimming levels or opposite dimming directions (e.g. after a system extension), all LED control gears can be synchronized to 50 % dimming level by a 10 s push. Use of pushbutton with indicator lamp is not permitted.

5.3 PowerLineCommunication (PLC)

The communication between the LED control gear and the LMI DC/DC-LED Driver is done over power line. The DALI signal will be modulated by the LED control gear and will be sent over the 48 V DC signal to the DC/DC-LED driver.

6. Functions

6.1 Short-circuit behaviour

In case of a short-circuit at the output the output is switched off. After restart of the DC power supply the output will be activated again. The restart can be done via mains reset.

6.2 No-load operation

The DC power supply will not be damaged in no-load operation.

6.3 Overload protection

If the output power range is exceeded by a defined internal limit, the DC power supply will give a signal to the DC/DC-LED driver, it will blink 5 times. After a break of 30 seconds, it will check again:

- If there is no overload anymore, the device will switch back to normal operation.
- If there is still overload, the device will blink again 5 times.

6.4 Overtemperature protection

The DC power supply will blink 3 times, after 30 s break, it checks again, if:

- there is no overtemperature, then the device will go in normal operation.
- there is still overtemperature, then the device will blink again 3 times.

6.5 corridorFUNCTION

Is set in the DC/DC-LED driver.

6.6 Software / programming

With appropriate software and a interface different functions can be activated and various parameters can be configured in the LED control gear. To do so, a DALI-USB programmer and the software (masterCONFIGURATOR) are required.

6.7 masterCONFIGURATOR

From version 2.8:

For programming functions (power-up fading, corridorFUNCTION) and device settings (fade time, ePowerOnLevel etc.). For further information see masterCONFIGURATOR manual.

7. Miscellaneous

7.1 Insulation and electric strength testing of luminaires

Electronic devices can be damaged by high voltage. This has to be considered during the routine testing of the luminaires in production.

According to IEC 60598-1 Annex Q (informative only!) or ENEC 303-Annex A, each luminaire should be submitted to an insulation test with 500 V_{DC} for 1 second. This test voltage should be connected between the interconnected phase and neutral terminals and the earth terminal.

The insulation resistance must be at least 2 MΩ.

As an alternative, IEC 60598-1 Annex Q describes a test of the electrical strength with 1500 V_{AC} (or 1.414 x 1500 V_{DC}). To avoid damage to the electronic devices this test must not be conducted.

7.2 Conditions of use and storage

Humidity: 5% up to max. 85%,
not condensed
(max. 56 days/year at 85%)

Storage temperature: -40 °C up to max. +80 °C

The devices have to be acclimatised to the specified temperature range (ta) before they can be operated.

The LED driver is declared as inbuilt LED controlgear, meaning it is intended to be used within a luminaire enclosure.

If the product is used outside a luminaire, the installation must provide suitable protection for people and environment (e.g. in illuminated ceilings).

7.3 Additional information

Additional technical information at www.tridonic.com → Technical Data

Lifetime declarations are informative and represent no warranty claim. No warranty if device was opened.