

**Driver LCI 15W 350/500/700mA stepDIM Ip**

advanced series

**Product description**

- \_ Constant current LED driver for luminaire installation
- \_ Implemented stepDIM function
- \_ 10 or 30 % dimming level settable
- \_ Output dimmed analogue (current amplitude)
- \_ Can be used with a standard motion detector (Simple CORRIDOR FUNCTION)
- \_ Type of protection IP20
- \_ Push-in terminals
- \_ Connecting cable, wire cross-section 0.5 – 1.5 mm<sup>2</sup>
- \_ SELV
- \_ 350, 500 or 700 mA output current
- \_ Output power 15/16/16.5 W
- \_ Nominal lifetime of 50,000 h (at ta max. with a failure rate ≤ 0.2 % per 1,000 h)
- \_ 5 years guarantee (conditions at <https://www.tridonic.com/en/int/services/manufacturer-guarantee-conditions>)

**Properties**

- \_ Casing: polycarbonate, white
- \_ Compact dimensions
- \_ Overload protection
- \_ Short-circuit protection
- \_ No-load protection

**Website**

<http://www.tridonic.com/89800277>



Linear



High bay



Decorative



Downlights



Spotlights



Free-standing



Area



Floor | Wall



Street

## Driver LCI 15W 350/500/700mA stepDIM Ip

advanced series

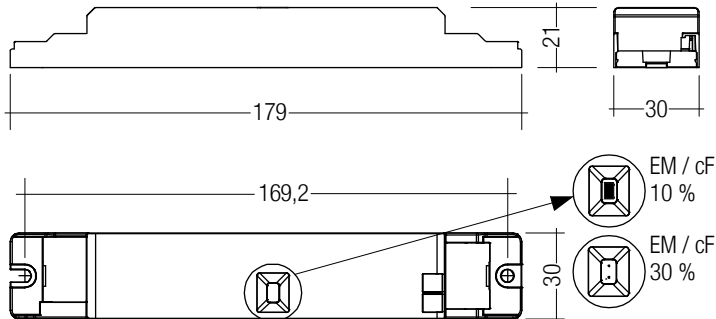

## Ordering data

Type	Article number	Packaging, carton	Packaging, pallet	Weight per pc.
LCI 15W 350mA stepDIM Ip	89800277	10 pc(s).	800 pc(s).	0.064 kg
LCI 15W 500mA stepDIM Ip	89800278	10 pc(s).	800 pc(s).	0.066 kg
LCI 15W 700mA stepDIM Ip	89800279	10 pc(s).	800 pc(s).	0.065 kg

## Technical data

Rated supply voltage	220 – 240 V
AC voltage range	198 – 264 V
DC voltage range	176 – 280 V
Mains frequency	0 / 50 / 60 Hz
Output current tolerance (normal operation 100 %) <sup>①</sup>	± 7,5 %
Typ. current ripple (at 230 V, 50 Hz, full load)	± 15 %
Max. output current peak (repetitive)	≤ output current + 24 %
Max. non-repetitive output peak current	≤ output current + 24 %
λ at full load	0.99
λ over full operating range (min.)	0.97
Starting time (at 230 V, 50 Hz, full load)	≤ 0.1 s
Turn off time (at 230 V, 50 Hz, full load)	≤ 0.1 s
Hold on time at power failure (output)	0 s
Storage temperature t <sub>s</sub>	-40 ... +85 °C
Max. output voltage (U-OUT)	60 V
Lifetime	up to 50,000 h
Guarantee (conditions at <a href="http://www.tridonic.com">www.tridonic.com</a> )	5 Year(s)
Dimensions L x W x H	179 x 30 x 21 mm

## Approval marks



## Standards

EN 55015, EN 61000-3-2, EN 61000-3-3, EN 61347-1, EN 61347-2-13, EN 61547, EN 62384

## Specific technical data

Type	Typ. output current	Output current tolerance	Min. output voltage	Max. output voltage	Typ. output power	Typ. power consumption	Typ. current consumption	tc point max.	Ambient temperature ta
<b>Normal operation 100 % (LCI 15W 350mA)</b>									
LCI 15W 350mA stepDIM Ip	350 mA	± 7,5 %	21.0 V	46.0 V	16.0 W	20.0 W	89 mA	90 °C	-25 ... +50 °C
<b>Operation cF / EM 30 % (LCI 15W 350mA)</b>									
LCI 15W 350mA stepDIM Ip	105 mA	± 25 %	21.0 V	46.0 V	4.8 W	6.2 W	60 mA	90 °C	-25 ... +50 °C
<b>Operation cF / EM 10 % (LCI 15W 350mA)</b>									
LCI 15W 350mA stepDIM Ip	35 mA	± 25 %	21.0 V	46.0 V	1.6 W	2.7 W	19 mA	90 °C	-25 ... +50 °C
<b>Normal operation 100 % (LCI 15W 500mA)</b>									
LCI 15W 500mA stepDIM Ip	500 mA	± 7,5 %	13.5 V	33.5 V	16.5 W	20.5 W	86 mA	85 °C	-25 ... +55 °C
<b>Operation cF / EM 30 % (LCI 15W 500mA)</b>									
LCI 15W 500mA stepDIM Ip	150 mA	± 25 %	13.5 V	33.5 V	4.9 W	6.3 W	57 mA	85 °C	-25 ... +55 °C
<b>Operation cF / EM 10 % (LCI 15W 500mA)</b>									
LCI 15W 500mA stepDIM Ip	50 mA	± 25 %	13.5 V	33.5 V	1.7 W	3.0 W	20 mA	85 °C	-25 ... +55 °C
<b>Normal operation 100 % (LCI 15W 700mA)</b>									
LCI 15W 700mA stepDIM Ip	700 mA	± 7,5 %	10.0 V	21.5 V	15.0 W	19.0 W	84 mA	85 °C	-25 ... +55 °C
<b>Operation cF / EM 30 % (LCI 15W 700mA)</b>									
LCI 15W 700mA stepDIM Ip	210 mA	± 25 %	10.0 V	21.5 V	4.5 W	5.8 W	51 mA	85 °C	-25 ... +55 °C
<b>Operation cF / EM 10 % (LCI 15W 700mA)</b>									
LCI 15W 700mA stepDIM Ip	70 mA	± 25 %	10.0 V	21.5 V	1.5 W	3.0 W	21 mA	85 °C	-25 ... +55 °C

① Output current is mean value.

**Standards**

EN 55015  
 EN 61000-3-2  
 EN 61000-3-3  
 EN 61347-1  
 EN 61347-2-13  
 EN 61547  
 EN 62384

**Overload protection**

If the maximum load is exceeded by a defined internal limit, the LED Driver reduces the LED output current.  
 After elimination of the overload the nominal operation is restored automatically.

**Short-circuit behaviour**

In case of a short circuit on the secondary side (LED) the LED Driver switches into hic-cup mode. After the removal of the short-circuit fault the LED Driver will recover automatically.

**No-load operation**

The LED Driver works in constant current mode. In no-load operation there is the max. output voltage at the output (see page 1).

**Installation instructions**

Note the requirements set out in the document  
 LED\_driver\_installation\_advice.pdf  
 (<http://www.tridonic.com/com/en/technical-data.asp>).

Hot plug-in or secondary switching of LEDs is not permitted and may cause a very high current to the LEDs.

**Glow wire test**

according to IEC 60695-2-11 with increased of 850 °C passed.

**Maximum loading of automatic circuit breakers in relation to inrush current**

Automatic circuit breaker type									Inrush current	
	C10	C13	C16	C20	B10	B13	B16	B20	I <sub>max</sub>	Time
Installation Ø	1.5 mm <sup>2</sup>	1.5 mm <sup>2</sup>	1.5 mm <sup>2</sup>	2.5 mm <sup>2</sup>	1.5 mm <sup>2</sup>	1.5 mm <sup>2</sup>	1.5 mm <sup>2</sup>	2.5 mm <sup>2</sup>		
<b>LCI 15W 350mA stepDIM Ip</b>	50	65	80	100	50	65	80	100	2 A	70 µs
<b>LCI 15W 500mA stepDIM Ip</b>	50	65	80	100	50	65	80	100	2 A	70 µs
<b>LCI 15W 700mA stepDIM Ip</b>	50	65	80	100	50	65	80	100	2 A	70 µs

This are max. values calculated out of inrush current! Please consider not to exceed the maximum rated continuous current of the circuit breaker.  
 Calculation uses typical values from ABB series S200 as a reference.  
 Actual values may differ due to used circuit breaker types and installation environment.

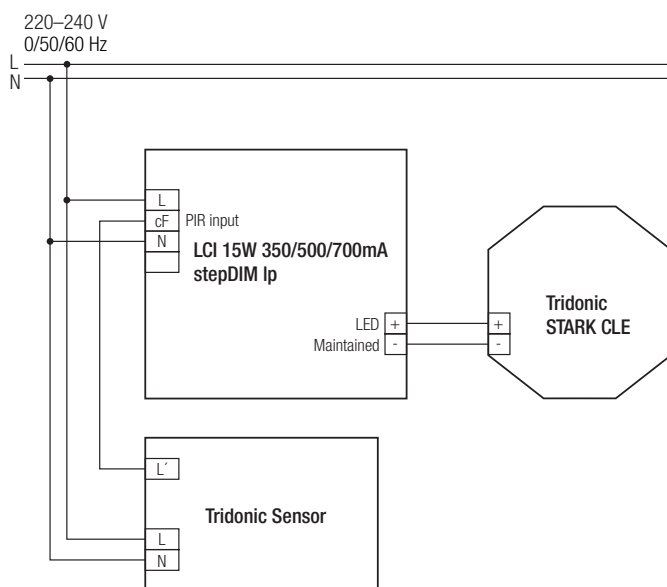
**Wiring diagram with sensor****Switching behaviour:**

L	cF	Jumper	Output LED
off	off	set / not set	off
off	on	set / not set	off
on	off	set	10 %
on	off	not set	30 %
on	on	set / not set	100 %

**DC operation behaviour:**

Emergency level at 10 %

The sensor is not active in DC operation.

## Wiring diagram normal operation with EM mode

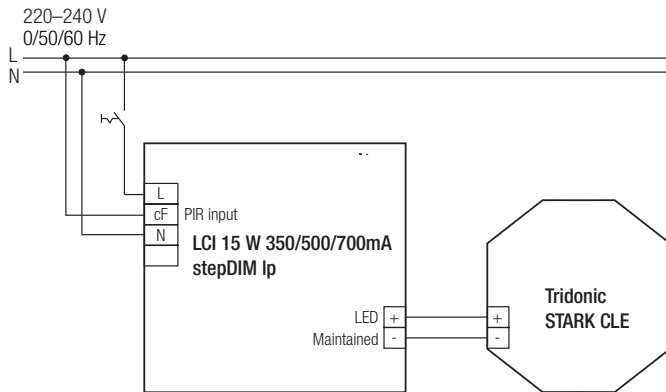

PIR input 230 V

The mains power must be removed before changing the LED load.

Secondary switching of LEDs is not allowed and may cause damage to the LEDs.

## Electrical connections

## Wiring

LED module/LED Driver/supply

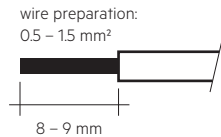

Loosen wire through twisting and pulling or using a  $\varnothing$  1 mm release tool

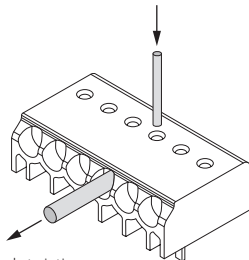

## Wiring type and cross section

Solid wire with a cross section of 0.5 – 1.5 mm<sup>2</sup>. Strip 8 – 9 mm of insulation from the cables to ensure perfect operation of terminals.

## Mounting of device

Max. torque for fixing: 0.5Nm/M4

## DC operation behaviour:

The emergency level (10 % or 100 %) depends on the polarity of the DC voltage.

L	+	-	+	-
N	-	+	-	+
CF	+	-	-	+
Emergency level	100 %	10 / 30 %*	10 / 30 %*	100 %

\* depending on the jumper setting (set: 10 %, not set: 30 %)

## Wiring guidelines

- All connections must be kept as short as possible to ensure good EMI behaviour.
- Mains leads should be kept apart from LED Driver and other leads (ideally 5 – 10 cm distance)
- Max. length of output wires is 30 cm.
- Incorrect wiring can damage LED modules.
- To avoid the damage of the Driver, the wiring must be protected against short circuits to earth (sharp edged metal parts, metal cable clips, louver, etc.).

## Insulation and electric strength testing of luminaires

Electronic devices can be damaged by high voltage. This has to be considered during the routine testing of the luminaires in production.

According to IEC 60598-1 Annex Q (informative only!) or ENEC 303-Annex A, each luminaire should be submitted to an insulation test with 500 V<sub>DC</sub> for 1 second. This test voltage should be connected between the interconnected phase and neutral terminals and the earth terminal. The insulation resistance must be at least 2 M $\Omega$ .

As an alternative, IEC 60598-1 Annex Q describes a test of the electrical strength with 1500 V<sub>AC</sub> (Or 1.414 x 1500 V<sub>DC</sub>). To avoid damage to the electronic devices this test must not be conducted.

## Conditions of use

The LED Driver is declared as inbuilt LED controlgear, meaning it is intended to be used within a luminaire enclosure.

If the product is used outside a luminaire, the installation must provide suitable protection for people and environment (e.g. in illuminated ceilings).

## Maximum number of switching cycles

All LED Driver are tested with 50,000 switching cycles.

## Additional information

Additional technical information at [www.tridonic.com](http://www.tridonic.com) → Technical Data

Lifetime declarations are informative and represent no warranty claim. No warranty if device was opened.