

Driver LCBU 25W 12V BASIC phase-cut SR

advanced series

**Product description**

- _ Dimmable via leading edge and trailing edge phase dimmers
- _ Dimming range typ. 5 to 100 % (depending on dimmer)
- _ Type of protection IP20
- _ Screw terminal
- _ Connecting cable, wire cross-section 0.5 – 2.5 mm²
- _ SELV
- _ 12 V DC output voltage
- _ Output power 25 W
- _ Nominal lifetime of 50,000 h (at max ta 50 °C with a failure rate ≤ 0.2 % per 1,000 h)
- _ 5 years guarantee (Conditions at <https://www.tridonic.com/en/int/services/manufacture-guarantee-conditions>)

Properties

- _ Casing: polycarbonate, white
- _ Compact dimensions
- _ Overload protection
- _ Short-circuit protection
- _ No-load protection

Website

<http://www.tridonic.com/89800290>



Linear



High bay



Decorative



Downlights



Spotlights



Free-standing



Area



Floor | Wall



Street

Driver LCBU 25W 12V BASIC phase-cut SR

advanced series

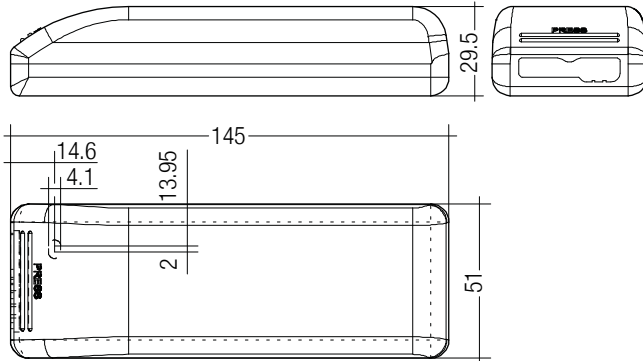

Ordering data

Type	Article number	Packaging, carton	Packaging, pallet	Weight per pc.
LCBU 25W 12V BASIC phase-cut SR	89800290	10 pc(s).	600 pc(s).	0.117 kg

Technical data

Rated supply voltage	220 – 240 V
AC voltage range	198 – 264 V
Mains frequency	50 / 60 Hz
Typ. rated current (at 230 V, 50 Hz, full load)	135 mA
λ at full load	0.97
λ over full operating range (min.)	0.75C
Typ. current ripple (at 230 V, 50 Hz, full load)	$\pm 30\%$
Output P _{ST_LM} (at full load)	≤ 1
Output SVM (at full load)	≤ 0.4
Starting time (at 230 V, 50 Hz, full load)	≤ 0.1 s
Turn off time (at 230 V, 50 Hz, full load)	≤ 0.1 s
Hold on time at power failure (output)	0 s
Ambient temperature t_a	-25 ... +50 °C
Ambient temperature t_a (at lifetime 50,000 h)	50 °C
Max. casing temperature t_c	75 °C
Storage temperature t_s	-40 ... +85 °C
Lifetime	up to 50,000 h
Guarantee (conditions at www.tridonic.com)	5 Year(s)
Dimensions L x W x H	145 x 51 x 29.5 mm

Approval marks



Standards

EN 55015, EN 61000-3-2, EN 61000-3-3, EN 61347-1, EN 61347-2-13, EN 61547, EN 62384

Specific technical data

Type	Efficiency η at full load	Efficiency η at min. load	Output current	Output voltage DC	Max. output voltage DC	Max. input power	Output power range
LCBU 25W 12V BASIC phase-cut SR	83 %	77 %	2,100 mA	11 – 15 V	15 V	30 W	8 – 25 W

① Test result at 230 V, 50 Hz.

1. Standards

- EN 55015
- EN 61000-3-2
- EN 61000-3-3
- EN 61347-1
- EN 61347-2-13
- EN 61547
- EN 62384

1.1 Glow wire test

according to IEC 60695-2-11 with increased temperature of 850 °C passed.

2. Installation / wiring

2.1 Circuit diagram

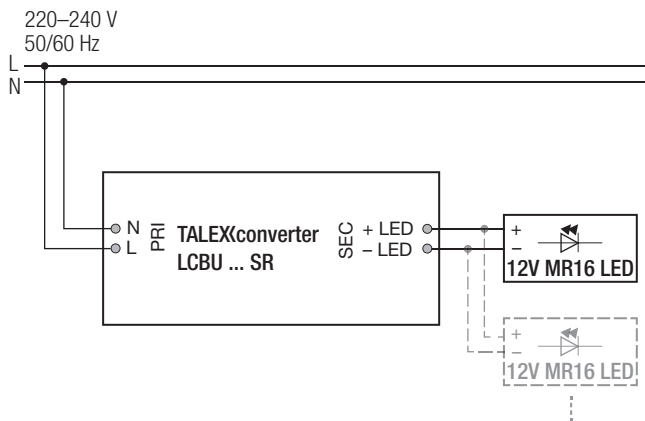

! Recommendation to check glowing at standby in combination with class I luminaires.

2.2 Wiring type and cross section

For wiring use stranded wire with ferrules or solid wire. For perfect function of the cage clamp terminals the strip length should be 4 – 5 mm for the input terminal. The max. torque at the clamping screw (M3) is 0.2 Nm.

Input terminal (D2)

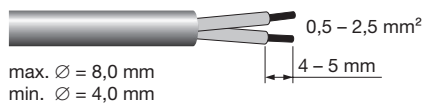

Output terminal (D1)

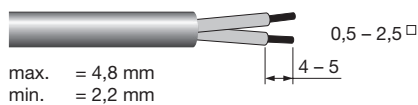

To get a proper working strain relief it is recommended that the cable jacket diameter of the side D2 is compared to the side D1 terminal according to the value table. (This can vary if the used cable jacket material varies from side D2 to D1 in pinching property).

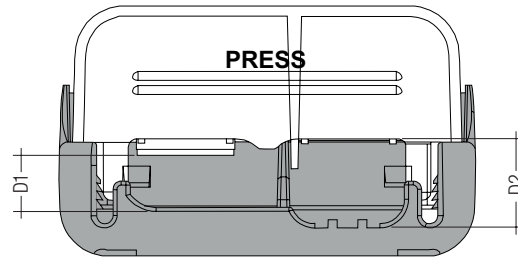

Depending on the used flaps of the terminal following cable jacket diameter difference between the side D2 and D1 terminals is recommended:

Side D1		Side D2		Difference D2 - D1
Housing bottom		Cover terminal		
With flap	Without flap	With flap	Without flap	
x	-	x	-	3.5 mm
x	-	x	-	5.5 mm
x	-	-	x	3.5 mm
-	x	x	-	3.5 mm
-	x	-	x	1.5 mm
x	-	-	x	1.5 mm
-	x	x	-	1.5 mm
-	x	-	x	-0.5 mm

2.3 Wiring instructions

The secondary leads should be separated from the mains connections and wiring for good EMC performance. Maximum lead length on secondary side is 3 x 2 m (parallel wiring of 12 V modules). For a good EMC performance keep the the LED wiring as short as possible. To comply with the EMC regulations run the secondary wires (LED module) in parallel. Through wiring is not possible.

To avoid damage of the Driver, the wiring must be protected against short circuits to earth (sharp edged metal parts, metal cable clips, louver, etc.).

2.4 Compatibility between LED driver and light source

The compatibility between LED driver and light source should be strictly checked in advance in a test.

2.5 Fixing conditions when using as independent Driver

Dry, acidfree, oilfree, fatfree. It is not allowed to exceed the maximum ambient temperature (ta) stated on the device. Minimum distances stated below are recommendations and depend on the actual luminaire. Device is not suitable for fixing in corner.

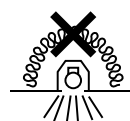
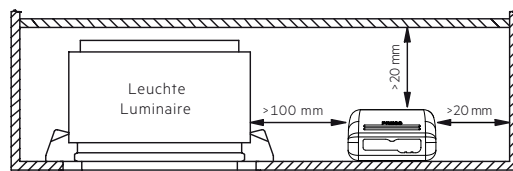

Device not suitable for covering with thermally insulating material according to IEC 60598-1 Ed.9

3. Electrical values

3.1 Maximum loading of automatic circuit breakers in relation to inrush current

Automatic circuit breaker type	C10	C13	C16	C20	B10	B13	B16	B20	Inrush current	
									Installation Ø	Installation Ø
LCBU 25W 12V basic phase-cut SR	35	45	55	70	35	45	55	70	1.7 A	40 µs

These are max. values calculated out of inrush current! Please consider not to exceed the maximum rated continuous current of the circuit breaker.

Calculation uses typical values from ABB series S200 as a reference.

Actual values may differ due to used circuit breaker types and installation environment.

4. Functions

4.1 Overload protection

If the maximum load is exceeded by a defined internal limit, the LED driver reduces the LED output current. After elimination of the overload the nominal operation is restored automatically.

4.2 Short-circuit behaviour

In case of a short circuit on the secondary side (LED) the LED driver switches into hic-cup mode. After the removal of the short-circuit fault the LED driver will recover automatically.

4.3 No-load operation

The LED driver works in constant current mode. In no-load operation there is the max. output voltage at the output (see page 1).

5.3 Maximum number of switching cycles

All LED driver are tested with 50,000 switching cycles.

5.4 Additional information

Additional technical information at www.tridonic.com → Technical Data

Lifetime declarations are informative and represent no warranty claim. No warranty if device was opened.

5. Miscellaneous

5.1 Insulation and electric strength testing of luminaires

Electronic devices can be damaged by high voltage. This has to be considered during the routine testing of the luminaires in production.

According to IEC 60598-1 Annex Q (informative only!) or ENEC 303-Annex A, each luminaire should be submitted to an insulation test with 500 V_{DC} for 1 second. This test voltage should be connected between the interconnected phase and neutral terminals and the earth terminal. The insulation resistance must be at least 2 MΩ.

As an alternative, IEC 60598-1 Annex Q describes a test of the electrical strength with 1500 V_{AC} (or 1.414 x 1500 V_{DC}). To avoid damage to the electronic devices this test must not be conducted.

5.2 Installation instructions

Note the requirements set out in the document
LED_driver_installation_advise.pdf
(<http://www.tridonic.com/com/en/technical-docs.asp>).

Hot plug-in or secondary switching of LEDs is not permitted and may cause a very high current to the LEDs.