

DSI-A/D

Converter for 1...10 V into DSI signal 1-channel for installation in luminaire

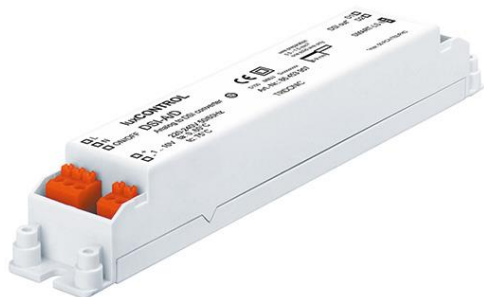

Product description

- _ Converter for converting analogue signals into DSI signals
- _ For connecting DSI devices in 1...10 V control systems
- _ For a maximum of 50 DSI devices
- _ Constant lighting control possible via terminal for SMART LS II
- _ On/off switching via separate switch input
- _ 5 years guarantee (conditions at

<https://www.tridonic.com/manufacturer-guarantee-conditions>)

Website

<http://www.tridonic.com/>



DSI-A/D

Converter for 1...10 V into DSI signal 1-channel for installation in luminaire

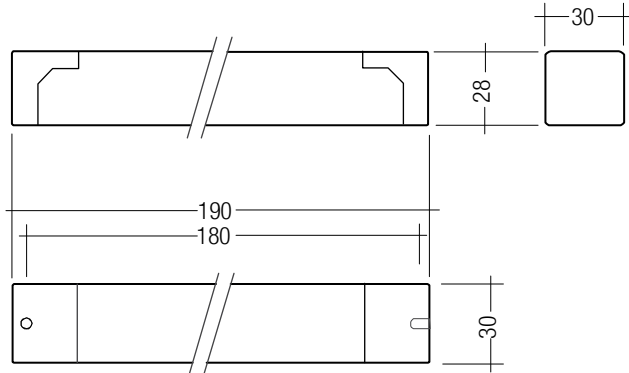

Approval marks





DSI-A/D
Control with a 1–10 V signal / ON/OFF with light switches

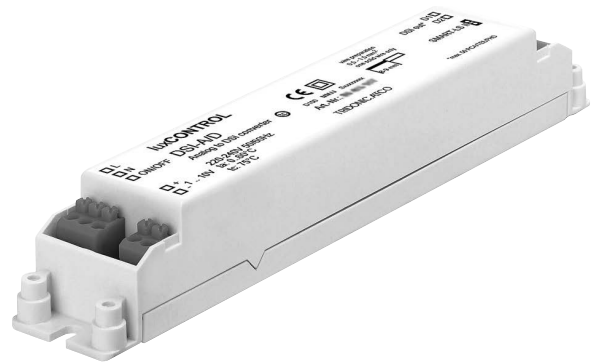
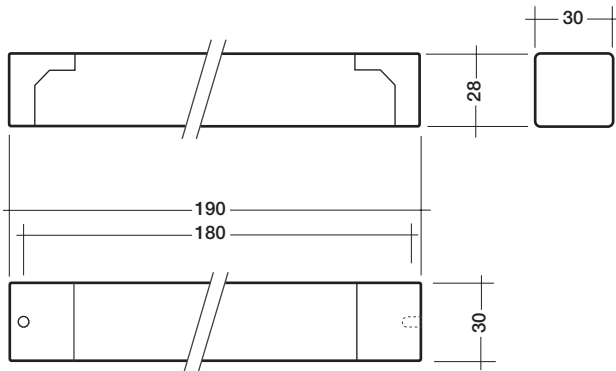

The DSI-A/D module converts an analogue 1–10 V signal into the digital DSI control signal. This enables PCA/TE one4all/PCD digital devices to be integrated in existing analogue control systems.

Operating devices connected can be adjusted for constant light by connecting a SMART LS II.

By connecting a SMART LS II the DSI-A/D can be used as a constant light control module.

This operation mode deactivates the analogue 1–10 V input. ON/OFF switching via the ON/OFF input is possible.

- terminal cover and strain relief enclosed
- 5-year guarantee

Packaging:
single packaged
box of 10

type		DSI-A/D	
article number:		28000850	
electrical supply:	voltage	V	230/240
	frequency	Hz	50/60
	max. load	VA	4
input:	dimming	V	1–10
	dimming potentiometer *	kΩ	47 (≥ 47 ≤ 100)
	ON/OFF push to make switches (220–240 V)	–	1
	ambient light sensor	–	1
output:	digital DSI control signal	–	1
	signal	–	digital/serial
	voltage	V	12 ± 10 %
	data rate	Bd	1 200
	max. number of	PCA/TE one4all/PCD	50
	max. cable length	m	100
temperature:	permitted ambient temperature	°C	0 → +60

* see page 2. Potentiometer with linear characteristics. Optimal 47 kΩ, 47–100 kΩ possible, load ≥ 0.5 W

Glow-wire test
according to EN 61347-1 passed.

If the 1-10 V input is open (unconnected) the lighting is set to maximum.

Control with passive potentiometers

To accurately adjust light levels it is recommended that you use a 47 kΩ potentiometer. If a 100 kΩ potentiometer is already in use, then install a resistor in parallel (68 kΩ, ≥ 0.5 W). Connect the 47 kΩ potentiometer only with a DSI A/D. The parallel wiring of the potentiometer is not allowed.

Control with a 1–10 V voltage source

The 1–10 V input is supplying a control current for operation with passive potentiometers. In the event of using an active voltage source please be aware that this source has to be able to sink a current of 2 mA to enable correct adjustment.

If the voltage source is not able to sink a 2 mA current it is possible to set a resistor (470 Ω, ≥ 0.5 W) in parallel. In this case the voltage source has to supply a minimum current of 20 mA to reach the maximum needed output voltage of +10 V.

Lamp power vs. 1–10 V control voltage

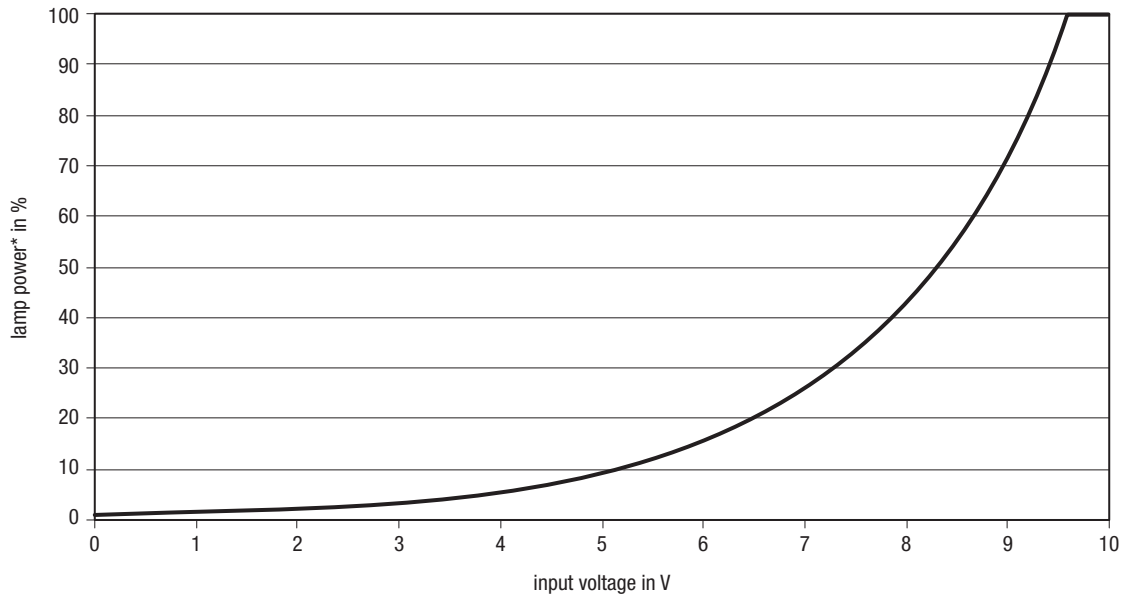

* The lamp power changes logarithmic to dim according the eye sensitivity.

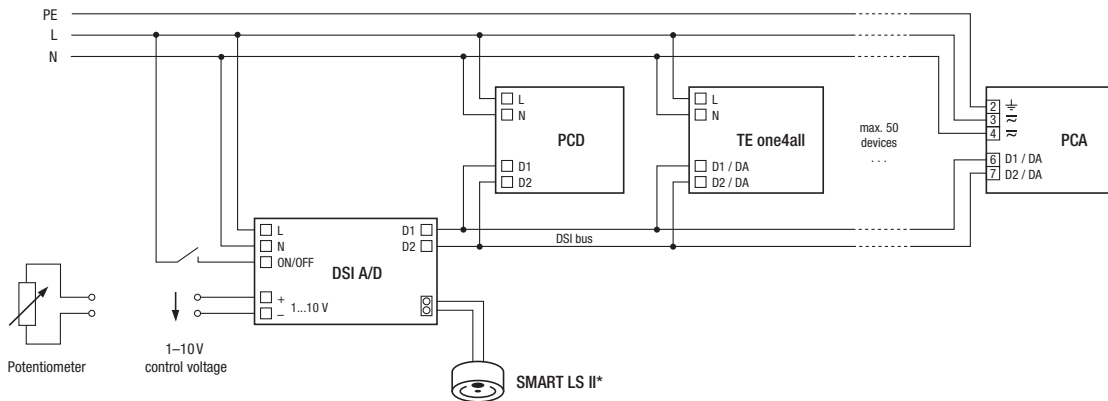

* is a SMART LS II sensor connected, the 1–10 V function is disabled.