

DLE G2 premium system

DLE premium system



Product description

- _ Tunable White system for Downlights with adjustable colour temperature from 2,700 to 6,500 K at constant luminous flux
- _ Precalibrated set to ensure light quality and high colour consistency, consisting of compact LED driver and LED module ①
- _ High colour rendering index CRI > 90
- _ Outstanding system colour tolerance
- _ High system efficiency up to 100 lm/W at $t_p = 65\text{ }^\circ\text{C}$
- _ LED module for Downlight applications with 2,000 or 3,000 lm
- _ Dimming range 1 – 100 % without change of colour temperature
- _ Long lifetime of 50,000 h and 5 years system guarantee (conditions at <https://www.tridonic.com/en/int/services/manufacturer-guarantee-conditions>)

Interfaces

- _ one4all (DALI DT8, DSI, switchDIM, corridorFUNCTION V2)
- _ colourSWITCH
- _ Push terminals for quick and simple wiring

Functions

- _ Constant light output function (CLO)
- _ colourSWITCH with predefined colours
- _ switchDIM and colourSWITCH with memory function
- _ Power-up fading and fade2zero
- _ Configurable via DALI
- _ Protective features (overtemperature, short-circuit, overload, no-load, reduced surge amplification)
- _ Suitable for emergency escape lighting systems acc. to EN 50172

Typical applications

- _ Downlight for retail and corridor applications
- _ Tunable white application

① Mixing of components from different sets is not allowed due to the pre-calibration of the system.



Website

<http://www.tridonic.com/89603257>



Linear



High bay



Decorative



Downlights



Spotlights



Free-standing



Area



Floor | Wall



Street

DLE G2 premium system
DLE premium system

Ordering data

Type	Article number	System components
DLE G2 60mm 2000lm 927-965 SR PRE KIT	89603257	LCA 38W PRE + 1 LED module DLE 2,000 lm
DLE G2 60mm 3000lm 927-965 SR PRE KIT	89603258	LCA 38W PRE + 1 LED module DLE 3,000 lm

Specific technical data

Type	Useful luminous flux at $T_p = 25^\circ\text{C}$ ②	Expected luminous flux at T_p rated ②	Power consumption P_{tot} at $T_p = 25^\circ\text{C}$ ③	Colour rendering index CRI	Energy classification
DLE G2 60mm 2000lm 927-965 SR PRE KIT	2,200 lm	2,000 lm	20.1 W	>90	A+
DLE G2 60mm 3000lm 927-965 SR PRE KIT	3,300 lm	3,000 lm	31.2 W	>90	A+

② Tolerance range for optical data over the CCT range: $\pm 5\%$ at dimming level 100 – 10 % / $\pm 10\%$ at dimming level <10 %.

③ Tolerance range for electrical data: $\pm 5\%$.

Module DLE G2 premium

Product description

1. Standards

EN 61000-4-6
 EN 61347-1
 EN 61547
 EN 62031
 EN 62471
 EN 62778

1.1 Photometric code

Key for photometric code, e. g. 930 / 349

1 st digit	2 nd + 3 rd digit	4 th digit	5 th digit	6 th digit
Code CRI	Colour temperature in Kelvin x 100	MacAdam initial	MacAdam after 25% of the life-time (max.6000h)	Luminous flux after 25% of the life-time (max.6000h)
7 70 – 79				Code Luminous flux
8 80 – 89				7 ≥ 70 %
9 ≥ 90				8 ≥ 80 % 9 ≥ 90 %

2. Thermal details

2.1 tc point, ambient temperature and life-time

The temperature at tp reference point is crucial for the light output and life-time of a LED product.

For DLE a tp temperature of 65°C has to be complied in order to achieve an optimum between heat sink requirements, light output and life-time.

Compliance with the maximum permissible reference temperature at the tc point must be checked under operating conditions in a thermally stable state. The maximum value must be determined under worst-case conditions for the relevant application.

The tc and tp temperature of LED modules from Tridonic are measured at the same reference point.

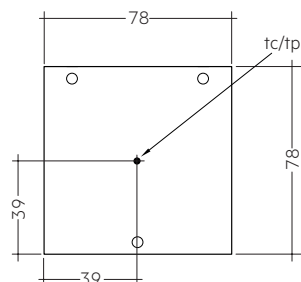

2.2 Storage and humidity

Storage temperature	-30...+80 °C
---------------------	--------------

Operation only in non condensing environment.
 Humidity during processing of the module should be between 30 to 70 %.

2.3 Thermal design and heat sink

The rated life of LED products depends to a large extent on the temperature. If the permissible temperature limits are exceeded, the life of the DLE will be strongly reduced or even destroyed.

2.4 Thermal design and heat sink

The rated life of LED products depends to a large extent on the temperature. If the permissible temperature limits are exceeded, the life of the DLE will be greatly reduced or the DLE may be destroyed.

2.5 Heat sink values

DLE G2 60mm 2000lm 927-965 SR PRE KIT

ta	tp	R ^{th, hs-a}
25°C	65°C	4.14 K/W
35°C	65°C	3.10 K/W
40°C	65°C	2.58 K/W
45°C	65°C	2.07 K/W
50°C	65°C	1.55 K/W
55°C	65°C	1.03 K/W
60°C	65°C	0.51 K/W

DLE G2 60mm 3000lm 927-965 SR PRE KIT

ta	tp	R ^{th, hs-a}
25°C	65°C	2.47 K/W
35°C	65°C	1.85 K/W
40°C	65°C	1.54 K/W
45°C	65°C	1.23 K/W
50°C	65°C	0.92 K/W
55°C	65°C	0.61 K/W
60°C	65°C	0.30 K/W

Notes

The actual cooling can differ because of the material, the structural shape, outside influences and the installation situation. A thermal connection between DLE and heat sink with heat-conducting paste or heat conducting adhesive film is absolutely necessary.

Additionally the DLE has to be fixed on the heat sink with M4 screws to optimise the thermal connection.

Use of thermal interface material with thermal conductivity of $\lambda > 1$ W/mK and layer thickness of interface material with max. 50 μm or a similar interface material where the quotient of layer thickness and thermal conductivity $b < 50$ $\mu\text{mmK/W}$.

3. Installation / wiring

3.1 Electrical supply/choice of LED Driver

DLE modules must be operated with SELV LED Drivers.



DLE modules are basic insulated up to 60 V SELV against ground and can be mounted directly on earthed metal parts of the luminaire. If the max. output voltage of the LED Driver (also against earth) is above 60 V SELV, an additional insulation between LED module and heat sink is required (for example by insulated thermal pads) or by a suitable luminaire construction.

At voltages > 60 V an additional protection against direct touch (test finger) to the light emitting side of the module has to be guaranteed. This is typically achieved by means of a non removable light distributor over the module.

3.2 Wiring

Wiring diagram for switchDIM and colourSWITCH for DLE premium

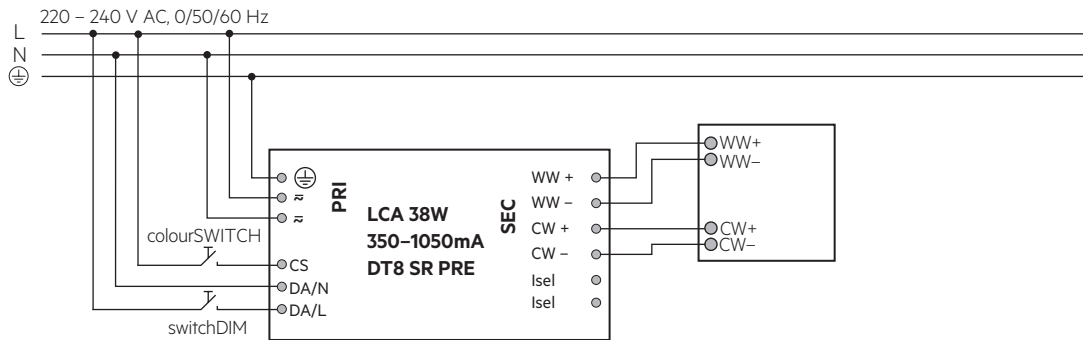

Wiring diagram for DALI for DLE premium

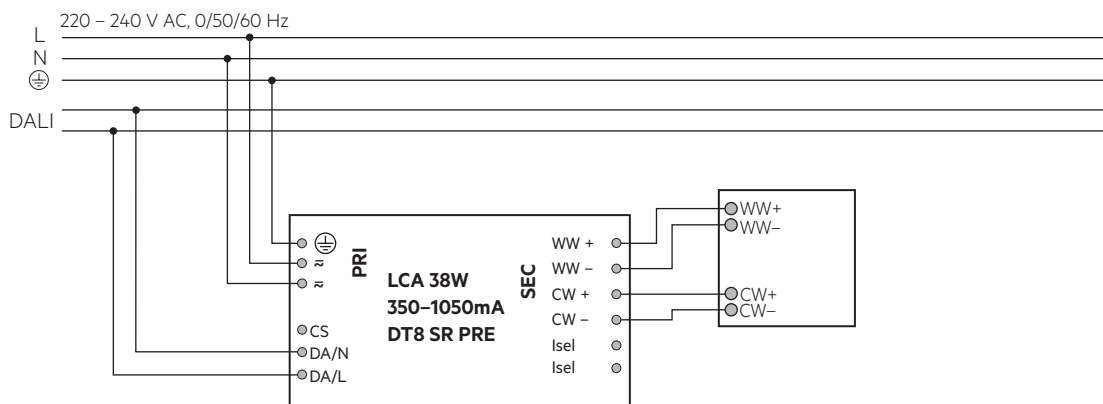

Wiring diagram for emergency

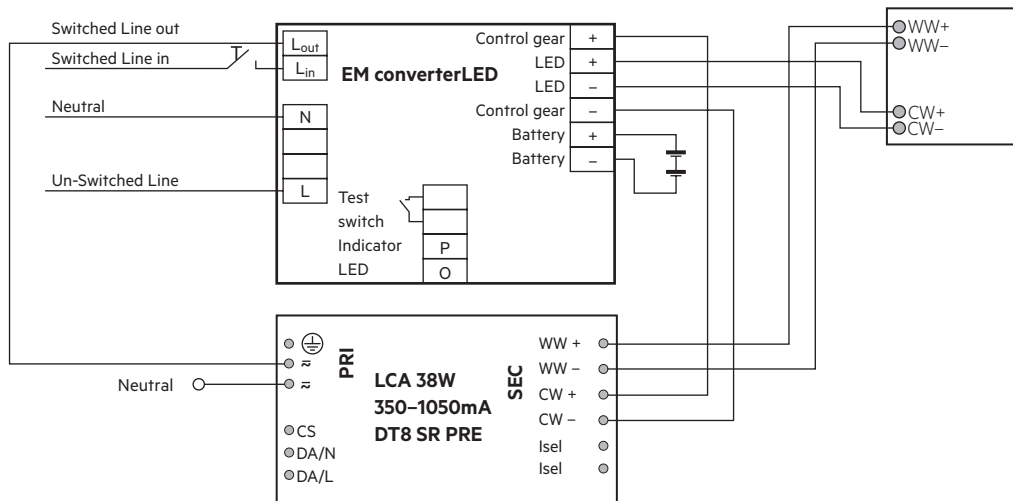

! Mixing of components from different sets is not allowed due to the pre-calibration of the system.

3.3 Wiring type and cross section

The wiring can be solid cable with a cross section of 0.25 to 0.75 mm². For the push-wire connection you have to strip the insulation (7–9 mm).

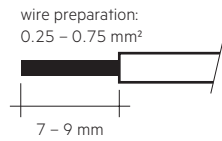

Inserting stranded wires / removing wires by lightly pressing on the push button.

3.4 Mounting instruction



None of the components of the DLE (substrate, LED, electronic components etc.) may be exposed to tensile or compressive stresses.

Max. torque for fixing: 0.5 Nm.

The LED modules are mounted with 4 screws per module. In order not to damage the modules only rounded head screws and an additional plastic flat washer should be used.



Chemical substance may harm the LED module. Chemical reactions could lead to colour shift, reduced luminous flux or a total failure of the module caused by corrosion of electrical connections.

Materials which are used in LED applications (e.g. sealings, adhesives) must not produce dissolver gas. They must not be condensation curing based, acetate curing based or contain sulfur, chlorine or phthalate.

Avoid corrosive atmosphere during usage and storage.

3.5 EOS/ESD safety guidelines



The device / module contains components that are sensitive to electrostatic discharge and may only be installed in the factory and on site if appropriate EOS/ESD protection measures have been taken. No special measures need be taken for devices/modules with enclosed casings (contact with the pc board not possible), just normal installation practice. Please note the requirements set out in the document EOS / ESD guidelines (Guideline_EOS_ESD.pdf) at: <http://www.tridonic.com/esd-protection>

4. Life-time

4.1 Life-time, lumen maintenance and failure rate

The light output of an LED module decreases over the life-time, this is characterized with the L value.

L70 means that the LED module will have 70 % of its initial luminous flux after the stated operating time. This value is always related to the number of operation hours and therefore defines the life-time of an LED module.

As the L value is a statistical value the lumen maintenance may vary over the delivered LED modules.

The B value defines the amount of modules which are below the specific L value, e.g. L70B10 means 10 % of the LED modules are below 70 % of the initial luminous flux, respectively 90 % will be above 70 % of the initial value.

In addition the percentage of failed modules (fatal failure) is characterized by the C value.

The F value is the combination of the B and C value. That means for F degradation and complete failures are considered, e.g. L70F10 means 10 % of the LED modules may fail or be below 70 % of the initial luminous flux.

Life-time declarations are informative and represent no warranty claim.

4.2 Lumen maintenance for DLE

Forward current	tp temperature	L90 / F10	L90 / F50	L80 / F10	L80 / F50	L70 / F10	L70 / F50
700 mA	45 °C	>50,000 h	>50,000 h	>50,000 h	>50,000 h	>50,000 h	>50,000 h
	50 °C	45,000 h	>50,000 h	>50,000 h	>50,000 h	>50,000 h	>50,000 h
	55 °C	39,000 h	>50,000 h	>50,000 h	>50,000 h	>50,000 h	>50,000 h
	60 °C	34,000 h	>50,000 h	>50,000 h	>50,000 h	>50,000 h	>50,000 h
	65 °C	29,000 h	46,000 h	>50,000 h	>50,000 h	>50,000 h	>50,000 h
	70 °C	25,000 h	40,000 h	>50,000 h	>50,000 h	>50,000 h	>50,000 h
	75 °C	22,000 h	34,000 h	>50,000 h	>50,000 h	>50,000 h	>50,000 h
	80 °C	19,000 h	29,000 h	44,000 h	>50,000 h	>50,000 h	>50,000 h
	85 °C	17,000 h	25,000 h	38,000 h	>50,000 h	>50,000 h	>50,000 h

5. Photometric characteristics

5.1 Coordinates and tolerances according to CIE 1931

The specified colour coordinates are integral measured by a current impulse of 750 mA / 2,700 K and 600 mA / 6,500 K and a duration of 100 ms. The ambient temperature of the measurement is $t_a = 25^\circ\text{C}$. The measurement tolerance of the colour coordinates are ± 0.01 .

2,700 K

	x0	y0
Centre	0.4578	0.4101

MacAdam ellipse: 3SDCM

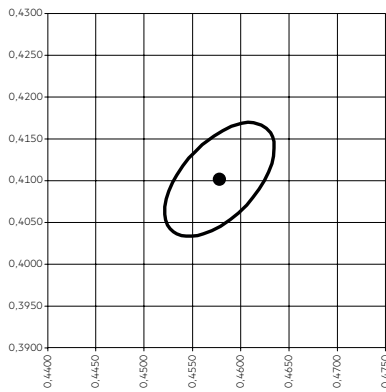

6,500 K

	x0	y0
Centre	0.3123	0.3282

MacAdam ellipse: 3SDCM

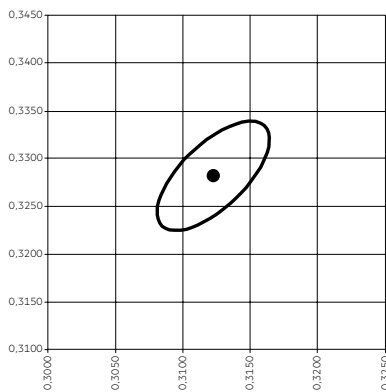

Colour spectrum at different colour temperatures

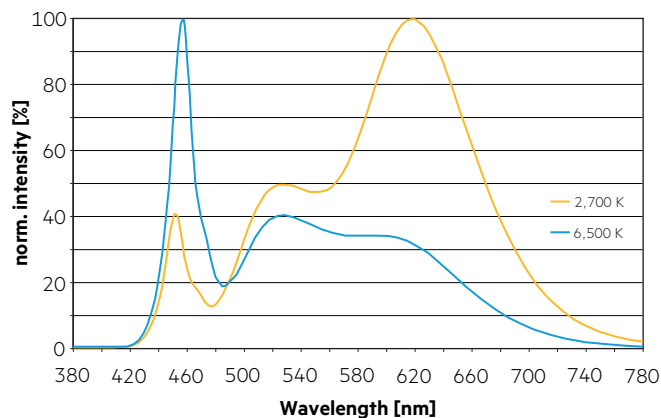

5.2 Light distribution

The optical design of the DLE product line ensures optimum homogeneity for the light distribution.



The colour temperature is measured integral over the complete module.

To ensure an ideal mixture of colours and a homogeneous light distribution a suitable optic (e. g. PMMA diffuser) and a sufficient spacing between module and optic (typ. 6 cm) should be used.

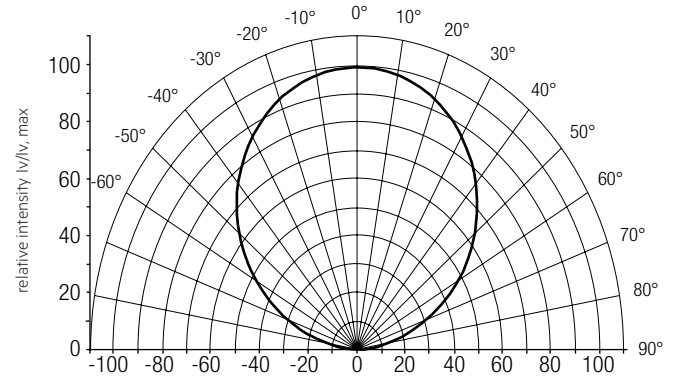

For further information see Design-in Guide, 3D data and photometric data on www.tridonic.com or on request.

5.3 Relative luminous flux vs. operating temperature

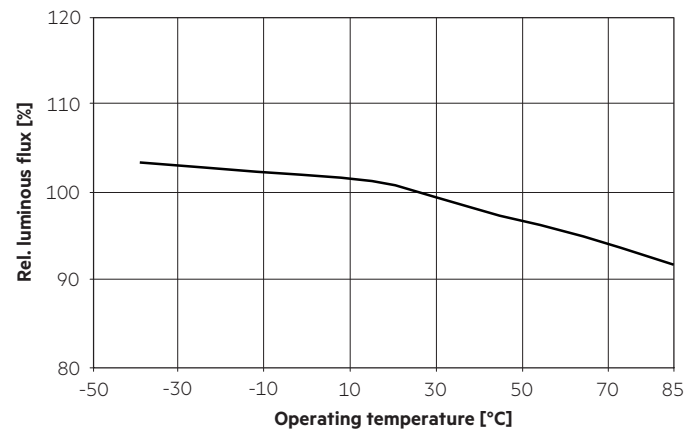

The diagrams are based on statistic values.

6. Miscellaneous

6.1 Additional information

Additional technical information Design-in Guide, 3D data, photometric data and Guarantee conditions at www.tridonic.com

7. Photometric characteristics system

7.1 Coordinates and tolerances according to CIE 1931

The specified colour coordinates are integral measured by a current impulse of 100 ms.

The ambient temperature of the measurement is $t_a = 25\text{ }^\circ\text{C}$.

The measurement tolerance of the colour coordinates are ± 0.01 .

	2,700 K		3,000 K		3,500 K		4,000 K		4,500 K		5,000 K		5,500 K		6,000 K		6,500 K	
	x0	y0	x0	y0	x0	y0	x0	y0	x0	y0	x0	y0	x0	y0	x0	y0	x0	y0
Centre	0.4578	0.4101	0.4335	0.3964	0.4013	0.3783	0.3778	0.3651	0.3596	0.3548	0.3448	0.3465	0.3324	0.3395	0.3220	0.3336	0.3123	0.3282
MacAdam ellipse 100 – 50 % dimming level	3 SDCM																	
MacAdam ellipse 50 – 10 % dimming level	4 SDCM																	
MacAdam ellipse 10 – 3 % dimming level	6 SDCM																	
MacAdam ellipse 10 – 3 % dimming level	not specified																	

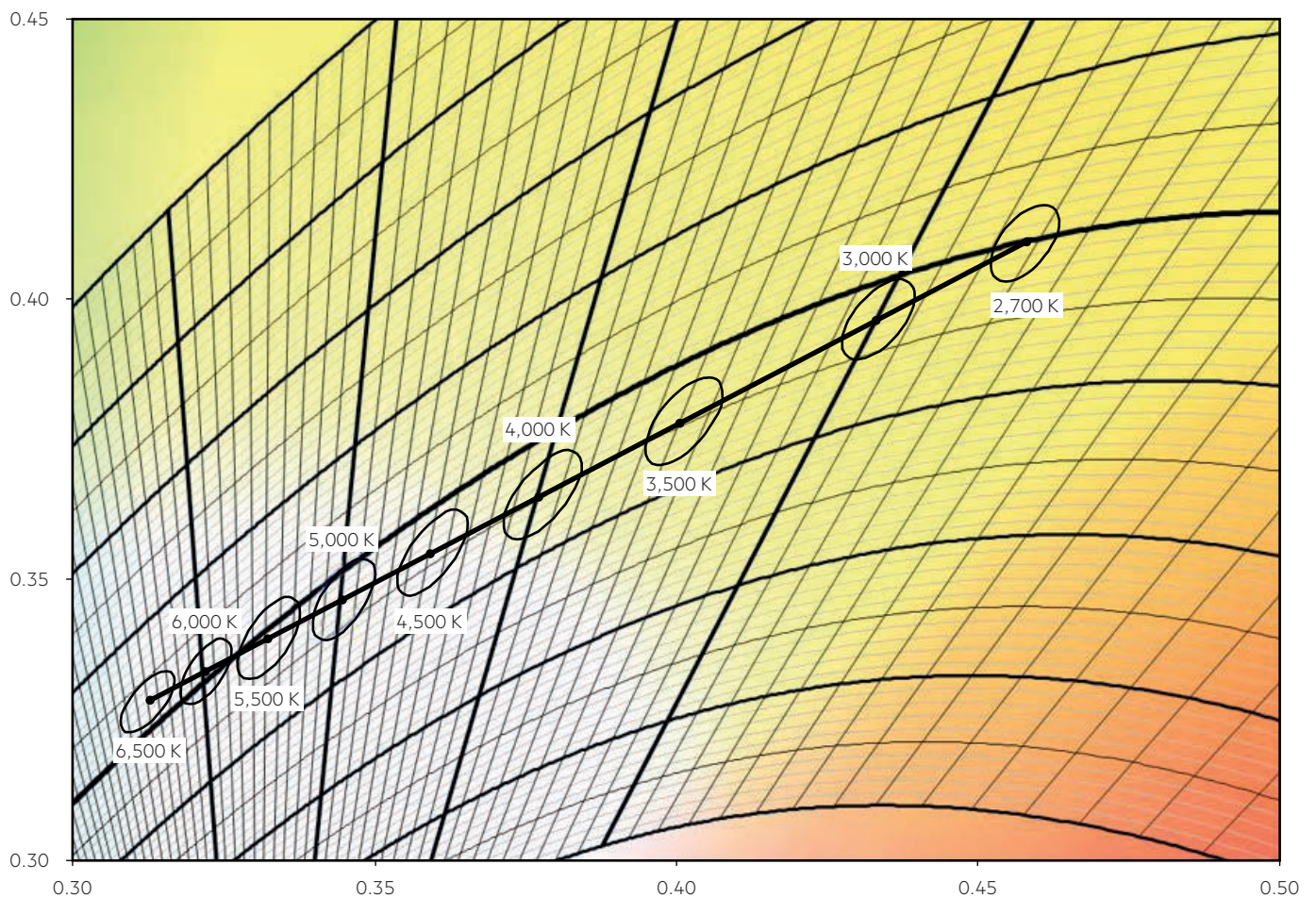

7.2 Colour spectrum at different colour temperatures

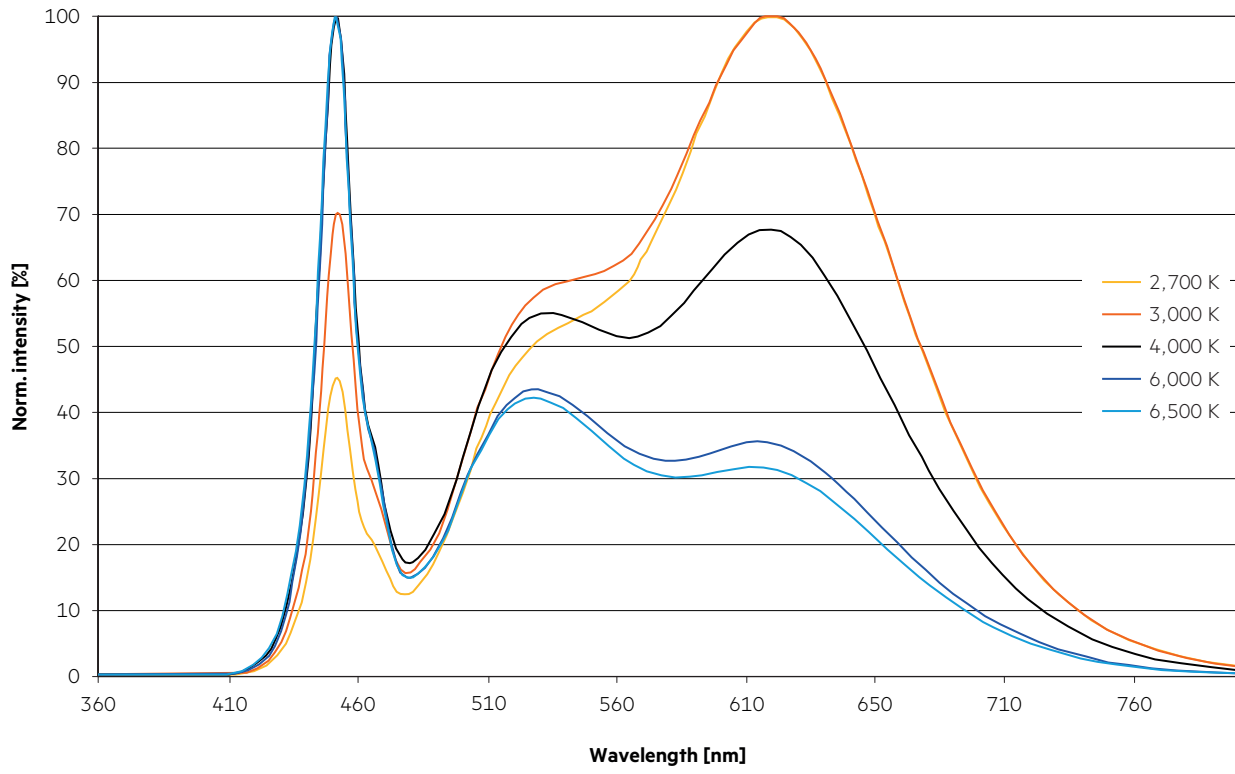

Driver LCA 38W 350–1050mA DT8 SR PRE

Product description

1. Standards

EN 55015
 EN 61000-3-2
 EN 61000-3-3
 EN 61347-1
 EN 61347-2-13
 EN 62384
 EN 61547
 EN 62386-101 (according to DALI standard V2)
 EN 62386-102
 EN 62386-207
 According to EN 50172 for use in central battery systems
 According to EN 60598-2-22 suitable for emergency lighting installations

2. Thermal details and life-time

2.1 Expected life-time

Expected life-time									
Type	Output current	ta	30 °C	35 °C	40 °C	45 °C	50 °C	55 °C	60 °C
LCA 38W 350-1050mA DT8 SR PRE	350 mA	tc	50 °C	53 °C	58 °C	60 °C	65 °C	70 °C	75 °C
		Life-time	> 100,000 h	> 100,000 h	> 100,000 h	> 100,000 h	> 100,000 h	90,000 h	65,000 h
	350 – 700 mA	tc	55 °C	58 °C	60 °C	65 °C	70 °C	75 °C	–
		Life-time	> 100,000 h	> 100,000 h	> 100,000 h	> 100,000 h	80,000 h	55,000 h	–
700 – 1,050 mA	tc	60 °C	63 °C	65 °C	70 °C	75 °C	–	–	
	Life-time	> 100,000 h	> 100,000 h	> 100,000 h	80,000 h	55,000 h	–	–	

The LED Driver is designed for a life-time stated above under reference conditions and with a failure probability of less than 10 %.

The relation of tc to ta temperature depends also on the luminaire design.

If the measured tc temperature is approx. 5 K below tc max., ta temperature should be checked and eventually critical components (e.g. ELCAP) measured. Detailed information on request.

3. Installation / wiring

3.1 Wiring type and cross section

Mains supply wires

Stranded wire or solid wire from 0.5 to 2.5 mm² may be used for wiring.
 Strip 10–11 mm of insulation from the cables to ensure perfect operation of the push terminals.

Use one wire for each terminal connector only.

Use each strain relief channel for one cable only.

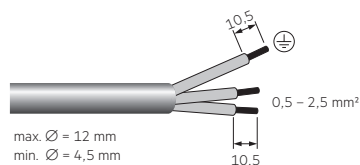

Secondary wires (LED module)

The wiring can be in stranded wires with ferrules or solid with a cross section of 0.2–1.5 mm².

Strip 8.5–9.5 mm of insulation from the cables to ensure perfect operation of the push-wire terminals.

Use one wire for each terminal connector only.

Use each strain relief channel for one cable only.

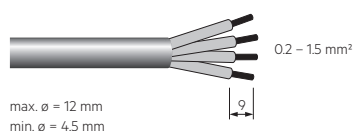

3.3 Loose wiring

Press down the “push button” and remove the cable from front.

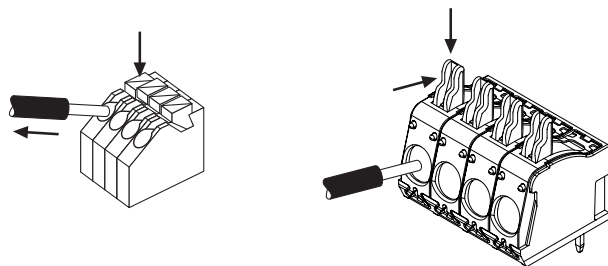

3.4 Fixing conditions

Dry, acidfree, oilfree, fatfree. It is not allowed to exceed the maximum ambient temperature (t_a) stated on the device. Minimum distances stated below are recommendations and depend on the actual luminaire. Is not suitable for fixing in corner.

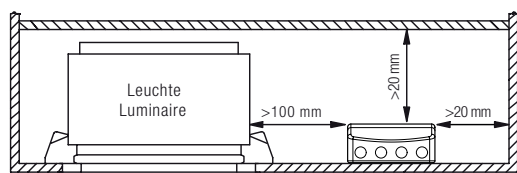

3.5 Wiring guidelines

- The cables should be run separately from the mains connections and mains cables to ensure good EMC conditions.
- The LED wiring should be kept as short as possible to ensure good EMC. The max. secondary cable length is 2 m (4 m circuit), this applies for LED output as well as for I-SELECT 2.
- Secondary switching is not permitted.
- The LED Driver has no inverse-polarity protection on the secondary side. Wrong polarity can damage LED modules with no inverse-polarity protection.
- Wrong wiring of the LED Driver can lead to malfunction or irreparable damage.
- Through wiring of mains is for connecting additional LED Driver only. Max. permanent current of 16 A may not be exceeded.

3.5 Hot plug-in

Hot plug-in is not supported due to residual output voltage of > 0 V. If a LED load is connected the device has to be restarted before the output will be activated again. This can be done via mains reset or via interface (DALI, DSI, switchDIM).

3.6 Earth connection

The earth connection is conducted as protection earth (PE). The LED Driver can be earthed via earth terminal. If the LED Driver will be earthed, protection earth (PE) has to be used. There is no earth connection required for the functionality of the LED Driver.

Earth connection is recommended to improve following behaviour:

- Electromagnetic interferences (EMI)
- LED glowing at stand-by
- Transmission of mains transients to the LED output

In general it is recommended to earth the LED Driver if the LED module is mounted on earthed luminaire parts respectively heat sinks and thereby representing a high capacity against earth.

3.7 I-SELECT 2 resistors connected via cable

For details see:

http://www.tridonic.com/com/en/download/technical/LCA_PRE_LC_EXC_ProductManual_en.pdf

4. Electrical values

4.1 Operating window

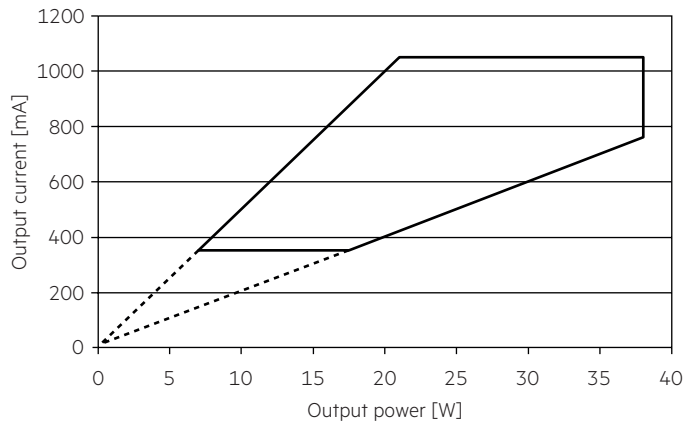
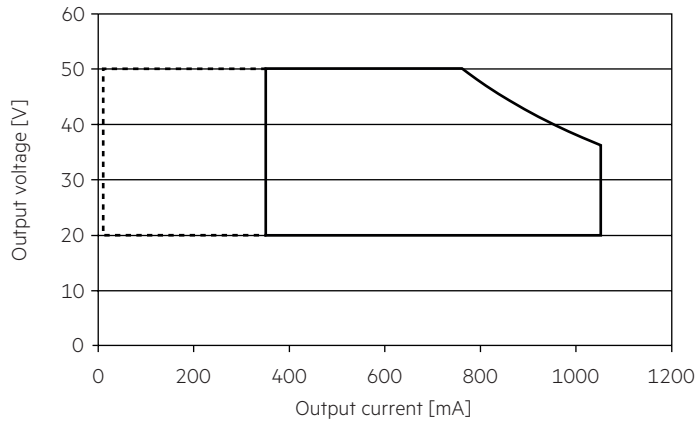

— Operating window 100 %
 - - - - - Operating window dimmed

Make sure that the LED Driver is operated within the given window under all operating conditions. Special attention needs to be paid at dimming and DC emergency operation as the forward voltage of the connected LED modules varies with the dimming level, due to the implemented amplitude dimming technology. Coming below the specified minimum output voltage of the LED Driver may cause the device to shut-down. See chapter "6.9 Light level in DC operation" for more information.

4.2 Efficiency vs load

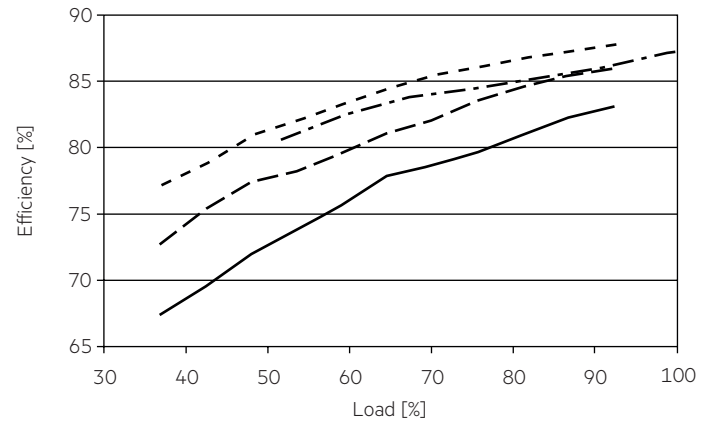

4.3 Power factor vs load

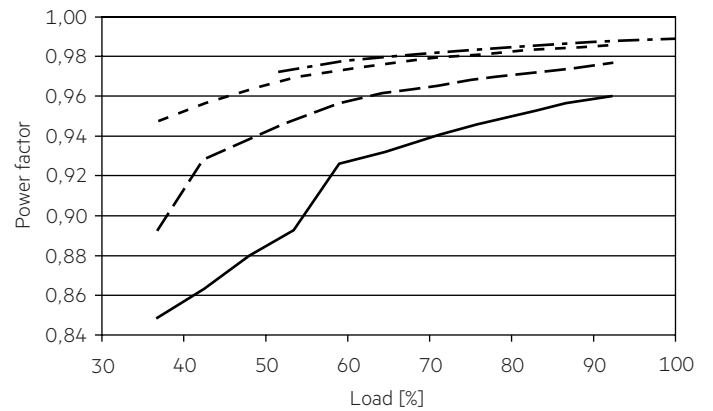

4.4 THD vs load

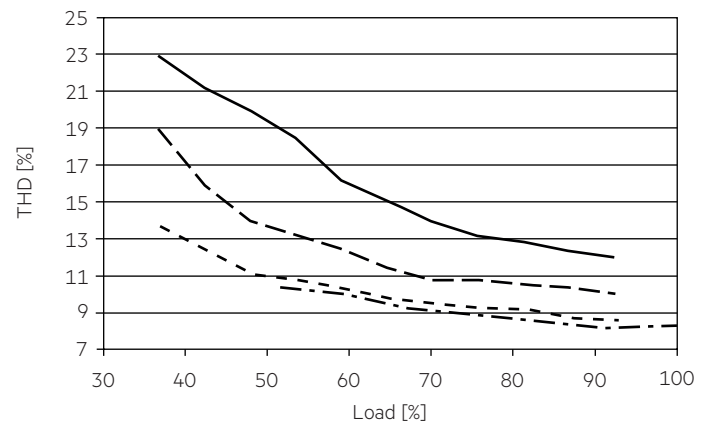

— 350 mA
 - - - - - 500 mA
 - · - · - 700 mA
 - - - - - 1050 mA

100 % load corresponds to the max. output power (full load) according to the table on page 2.

4.5 Maximum loading of automatic circuit breakers

Automatic circuit breaker type	C10	C13	C16	C20	B10	B13	B16	B20	Inrush current	
Installation \varnothing	1.5 mm ²	1.5 mm ²	2.5 mm ²	4 mm ²	1.5 mm ²	1.5 mm ²	2.5 mm ²	4 mm ²	I_{max}	time
LCA 38W 350-1050mA DT8 SR PRE	16	21	26	33	10	13	16	20	26 A	224 μ s

Calculation uses typical values from ABB series S200 as a reference.
Actual values may differ due to used circuit breaker types and installation environment.

4.6 Harmonic distortion in the mains supply (at 230 V / 50 Hz and full load) in %

	THD	3.	5.	7.	9.	11.
LCA 38W 350-1050mA DT8 SR PRE	< 10	< 10	< 3	< 3	< 2	< 2

4.7 Dimming

Dimming range 1% to 100 %

Digital control with:

- DSI signal: 8 bit Manchester Code
Speed 1% to 100% in 1.4 s
 - DALI signal: 16 bit Manchester Code
Speed 1% to 100% in 0.2 s
- Programmable parameter:
- Minimum dimming level
 - Maximum dimming level
 - Default minimum = 1%
 - Programmable range $1\% \leq \text{MIN} \leq 100\%$
 - Default maximum = 100%
 - Programmable range $100\% \geq \text{MAX} \geq 1\%$

Dimming curve is adapted to the eye sensitiveness.
Dimming is realized by amplitude dimming.

4.8 Dimming characteristics

Digital dimming value

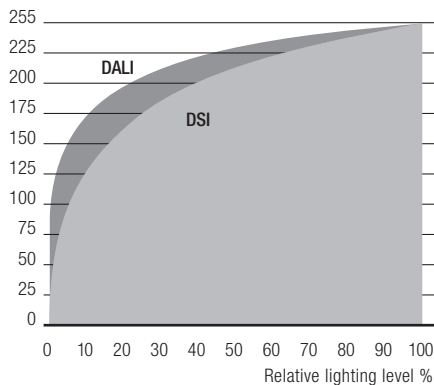

Dimming characteristics as seen by the human eye

5. Interfaces / communication

5.1 Control input (DA/N, DA/L)

Digital DALI signal or switchDIM can be wired on the same terminals (DA/N and DA/L).

The control input is non-polar for digital control signals (DALI, DSI). The control signal is not SELV. Control cable has to be installed in accordance to the requirements of low voltage installations.
Different functions depending on each module.

5.2 switchDIM

Integrated switchDIM function allows a direct connection of a pushbutton for dimming and switching.

Brief push (< 0.6 s) switches LED Driver ON and OFF. The dim level is saved at power-down and restored at power-up.

When the pushbutton is held, LED modules are dimmed. After releasing and pushing the LED modules are dimmed in the opposite direction.

In installations with LED Drivers with different dimming levels or opposite dimming directions (e.g. after a system extension), all LED Drivers can be synchronized to 50% dimming level by a 10 s push.

Use of pushbutton with indicator lamp is not permitted.

5.3 colourSWITCH

A conventional pushbutton can be used to control the system via colourSWITCH.

Use of pushbutton with indicator lamp is not permitted.

If the device is controlled via DALI/DSI, colourSWITCH is not available.

For control via a pushbutton different settings can be made:

- Short press: Setting the colour temperature via colourSWITCH mode with 9 values between 2,700 and 6,500 K.
- Long press (> 1 s): Stepless setting of colour temperature. After completion the colour temperature direction will be inverted.
- These values can be changed via masterCONFIGURATOR.
- Alternatively the colour temperature could be changed via DALI device type 8 control system.

In installations with LED Drivers with different colour temperature or opposite colour temperature directions (e.g. after a system extension), all LED Drivers can be synchronized to 4,500 K by a 10 s push.

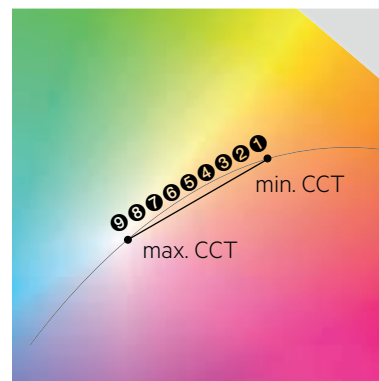

6. Functions

6.1 Function: adjustable current

The output current of the LED Driver can be adjusted in a certain range. For adjustment there are two options available.

Option 1: DALI

Adjustment is done by masterCONFIGURATOR (see masterCONFIGURATOR documentation).

Adjustment can be done for each channel individually.

Option 2: I-SELECT 2

By inserting a suitable resistor into the I-SELECT 2 interface, the current value can be adjusted. The relationship between output current and resistor value can be found in the chapter "Accessories I-SELECT 2 Plugs".



Please note that the resistor values for I-SELECT 2 are not compatible with I-SELECT (generation 1). Installation of an incorrect resistor may cause irreparable damage to the LED module(s). The I-SELECT 2 adjustment will be taken for all channels.

Resistors for the main output current values can be ordered from Tridonic (see accessories).

The priority for current adjustment methods is DALI (highest priority), I-SELECT 2 (lowest priority).

6.2 Short-circuit behaviour

In case of a short-circuit at the LED output the LED output is switched off. After restart of the LED Driver the output will be activated again. The restart can either be done via mains reset or via interface (DALI, DSI, switchDIM).

6.3 No-load operation

The LED Driver will not be damaged in no-load operation. The output will be deactivated and is therefore free of voltage. If a LED load is connected the device has to be restarted before the output will be activated again.

6.4 Overload protection

If the output voltage range is exceeded the LED Driver turns off the LED output. After restart of the LED Driver the output will be activated again. The restart can either be done via mains reset or via interface (DALI, DSI, switchDIM).

6.5 Overtemperature protection

The LED Driver is protected against temporary thermal overheating. If the temperature limit is exceeded the output current of the LED module(s) is reduced. The temperature protection is activated approx. +5 °C above $t_{c\ max}$ (see page 2). On DC operation this function is deactivated to fulfill emergency requirements.

6.6 corridorFUNCTION

The corridorFUNCTION can be programmed in two different ways.

To program the corridorFUNCTION by means of software a DALI-USB interface is needed in combination with a DALI PS. The software can be the masterCONFIGURATOR.

To activate the corridorFUNCTION without using software a voltage of 230 V has to be applied for five minutes at the switchDIM connection.

The unit will then switch automatically to the corridorFUNCTION.

Note:

If the corridorFUNCTION is wrongly activated in a switchDIM system (for example a switch is used instead of pushbutton), there is the option of installing a pushbutton and deactivating the corridorFUNCTION mode by five short pushes of the button within three seconds.

switchDIM and corridorFUNCTION are very simple tools for controlling gears with conventional pushbuttons or motion sensors.

To ensure correct operation a sinusoidal mains voltage with a frequency of 50 Hz or 60 Hz is required at the control input.

Special attention must be paid to achieving clear zero crossings. Serious mains faults may impair the operation of switchDIM and corridorFUNCTION.

6.7 Constant light output (CLO)

The luminous flux of a LED decreases constantly over the life-time.

The CLO function ensures that the emitted luminous flux remains stable.

For that purpose the LED current will increase continuously over the LED life-time. In masterCONFIGURATOR it is possible to select a start value (in percent) and an expected life-time.

The LED Driver adjusts the current afterwards automatically.

6.8 Power-up/-down fading

The power-up/-down function offers the opportunity to modify the on-/off behaviour. The time for fading on or off can be adjusted in a range of 0.2 to 16 seconds. According to this value, the device dims either from 0 % up to the power-on level or from the current set dim level down to 0 %.

This feature applies while operating via switchDIM and when switching the mains voltage on or off.

By factory default no fading time is set (= 0 seconds).

6.9 Light level in DC operation

The LED Driver is designed to operate on DC voltage and pulsed DC voltage. For a reliable operation, make sure that also in DC emergency operation the LED Driver is run within the specified conditions as stated in chapter "4.1 operating window".

Light output level in DC operation: programmable 1 – 100 % (EOFi = 0.13).
 Default setting: 15 %
 Programming by DALI.
 In DC operation dimming mode can be activated.

Colour temperature in DC operation: programmable 2,700 – 6,500 K
 Default setting: 6,500 K
 Programming by DALI.

The voltage-dependent input current of Driver incl. LED module is depending on the used load.

The voltage-dependent no-load current of Driver (without or defect LED module) is for:
 AC: 22 mA (at 230 V, 50 Hz)
 DC: 6 – 10 mA (at 275 – 186 V, 0 Hz)

6.10 Software / programming

With appropriate software and an interface different functions can be activated and various parameters can be configured in the LED Driver. To do so, a DALI-USB and the software (masterCONFIGURATOR) are required.

6.11 masterCONFIGURATOR

From version 2.8:
 For programming functions (CLO, I-SELECT 2, power-up fading, corridorFUNCTION, colourSWITCH) and device settings (fade time, ePowerOnLevel, DC level, etc.).
 For further information see masterCONFIGURATOR manual.

6.12 deviceCONFIGURATOR

PC (windows) based software application to transfer parameters into our drivers.
 Workflow optimised for the use in OEM production line.
 For further information see deviceCONFIGURATOR manual.

7. Miscellaneous

7.1 Insulation and electric strength testing of luminaires

Electronic devices can be damaged by high voltage. This has to be considered during the routine testing of the luminaires in production.

According to IEC 60598-1 Annex Q (informative only!) or ENEC 303-Annex A, each luminaire should be submitted to an insulation test with 500 V_{DC} for 1 second. This test voltage should be connected between the interconnected phase and neutral terminals and the earth terminal.
 The insulation resistance must be at least 2 MΩ.

As an alternative, IEC 60598-1 Annex Q describes a test of the electrical strength with 1500 V_{AC} (or 1.414 x 1500 V_{DC}). To avoid damage to the electronic devices this test must not be conducted.

7.2 Conditions of use and storage

Humidity: 5% up to max. 85%,
 not condensed
 (max. 56 days/year at 85%)

Storage temperature: -40 °C up to max. +80 °C

The devices have to be acclimatised to the specified temperature range (ta) before they can be operated.

7.3 Additional information

Additional technical information at www.tridonic.com → Technical Data

Guarantee conditions at www.tridonic.com → Services

Life-time declarations are informative and represent no warranty claim.
 No warranty if device was opened.