

**DALI MSensor SFI 40 HF 5DP bDW**

Casambi Ready wireless sensor



DALI MSensor SFI 40 HF 5DP bDW



DALI MSensor SFI 40 HF 5DP bDW S

**Product description**

- \_ Can be integrated in Casambi systems (Casambi Ready)
- \_ Wireless controllable with an Android / iOS smart device
- \_ No need for an external gateway device
- \_ Forms automatically a wireless communication network with up to 250 nodes
- \_ Digital output: Standalone DALI (compatible)
- \_ Integrated switchable DALI power supply with 20 mA
- \_ Motion detector for luminaire installation
- \_ Motion detection through glass and thin materials (except metal)
- \_ 2 light sensor modes available, threshold mode for bright out control and closed loop regulation if threshold is disabled
- \_ Bright-out function: luminaire is not switched on if there is adequate brightness
- \_ Delay time, detection range and light value for the bright-out function can be set via 4remoteBT App
- \_ Max. installation height 5 m
- \_ Variable detection area (100 – 10 %)
- \_ Zero cross switching supported
- \_ 5 years guarantee (conditions at <https://www.tridonic.com/en/int/services/manufacturer-guarantee-conditions>)
- \_ We will provide security updates for the next five years after the date of purchase of this product

**Website**

<http://www.tridonic.com/28005971>



**DALI MSensor SFI 40 HF 5DP bDW**  
Casambi Ready wireless sensor

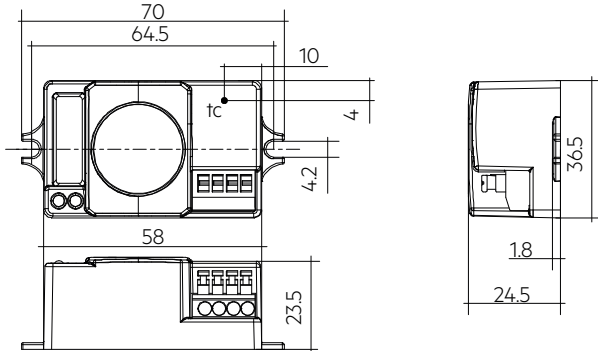

DALI MSensor SFI 40 HF 5DP bDW

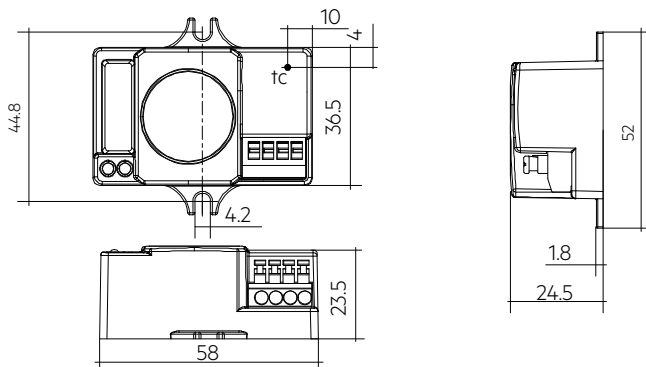

DALI MSensor SFI 40 HF 5DP bDW S

**Ordering data**

Type	Article number	Dimensions L x W x H	Packaging, carton	Weight per pc.
DALI MSensor SFI 40 HF 5DP bDW	28005971	70 x 36.5 x 24.5 mm	5 pc(s).	0.04 kg
DALI MSensor SFI 40 HF 5DP bDW S	28005972	58 x 52.0 x 24.5 mm	5 pc(s).	0.04 kg

**Technical data**

Rated supply voltage	220 – 240 V
Mains frequency	50 / 60 Hz
Max. mains current	6 mA
Power	< 12 W
Typ. power consumption <sup>①</sup>	0.7 W
Radio transceiver operating frequencies	2.4 – 2.483 GHz
Max. output power radio transceiver (E.I. R.P.) <sup>②</sup>	< + 20 dBm
Frequency	5.8 GHz (± 75 MHz)
Transmission power	< 0.2 mW
Radio protocol	Bluetooth 4.0 or 5.0 Low Energy (BLE)
Capable for mesh network	Up to 250 nodes / Standard networks and Long Range
Output	DALI (compatible)
Number of DALI addresses <sup>③</sup>	4
Guaranteed output current, DALI	20 mA
Max. output current, DALI	250 mA
Max. DALI wiring length	5 m at 1 mm <sup>2</sup>
Detection angle	30 – 150°
Max. detection area	ø 6 m
Max. mounting height	5 m
Max. casing temperature t <sub>c</sub>	70 °C
Ambient temperature t <sub>a</sub>	-20 ... +60 °C
Storage temperature t <sub>s</sub>	-20 ... +70 °C
Humidity	min. 5 ... max. 85 % at 30 °C
Type of protection	IP20
Protection class	II
Housing material	PC, halogen-free
Housing colour	RAL 9016 (white)
Lifetime	up to 50,000 h
Guarantee (conditions at <a href="http://www.tridonic.com">www.tridonic.com</a> )	5 Year(s)

**Approval marks****Standards**

EN 55015, EN 61000-3-2, EN 61000-3-3, EN 61547, EN 61347-1, EN 61347-2-11, EN 300 440, EN 301 489-1, EN 301 489-3, EN 301 489-17, EN 62479, EN 300 328, EN 62493, EN 62386-101, EN 62386-103

<sup>①</sup> Depending on the number of connected DALI loads.

<sup>②</sup> E.I.R.P.: Equivalent Isotropically Radiated Power.

<sup>③</sup> Assignment of max. 4 single / group addresses, depending on the device profile.

1. Standards

- EN 55015
- EN 61000-3-2
- EN 61000-3-3
- EN 61547
- EN 61347-1
- EN 61347-2-11
- EN 300 440
- EN 301 489-1
- EN 301 489-3
- EN 301 489-17
- EN 62479
- EN 300 328
- EN 62493
- EN 62386-101
- EN 62386-103

 Built-in electronic controlgear marked with this symbol provide double or reinforced insulation between hazardous live parts and all parts of the enclosure (complete or partial) that can come in contact with the luminaire body when incorporated.

 WARNING: FELV terminals marked "Risk of electric shock" are not safe to touch. Circuits connected to any FELV control terminal shall be insulated from the LV supply voltage of the control gear. Any terminals connected to the FELV circuit shall be protected against accidental contact.

1.1 Glow-wire test according to EN 60598-1

850 °C passed

2. Common

The MSensor SFI 40 HF 5DP bDW provides simple, cost-effective and wireless motion detection in combination with a Tridonic electronic dimmable control gear. If the user-definable light value at the integrated light sensor is exceeded the control gear remains switched off. With a light guide, the sensor can also be used for daylight control. High-frequency technology enables the sensor to be installed in completely enclosed luminaires. All basicDIM Wireless devices can be controlled with the Tridonic 4remote BT app. The app is available free of charge from the Apple App Store and Google Play Store.

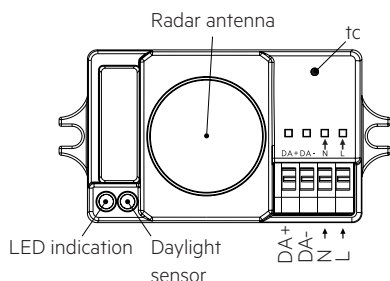

2.1 Operation

The MSensor SFI 40 HF 5DP bDW is fully compatible with networks which support up to 250 nodes (Evolution networks). If the sensor is used with different types of basicDIM Wireless devices in an Evolution network, check their compatibility in advance. The MSensor SFI 40 HF 5DP bDW is not compatible with classic networks.

Multiple devices automatically form a mesh network that is controllable from any point. These networks communicate wireless directly with the smartphone or tablet. Therefore an external gateway or wireless LAN network is not needed.

MSensor SFI 40 HF 5DP bDW devices have an integrated 2.4 GHz Bluetooth antenna. For optimal RF performance when integrated into a luminaire, special attention is required. See chapter 4.4 Placement for further instructions. Configure the settings and operating modes using the 4remote BT app.

3. Thermal details and lifetime

3.1 Expected lifetime

Expected lifetime		
Type	ta	60 °C
MSensor SFI 40 HF 5DP bDW	tc	70 °C
	Lifetime	50,000 h

The device is designed for a lifetime stated above under reference conditions and with a failure probability of less than 10 %.

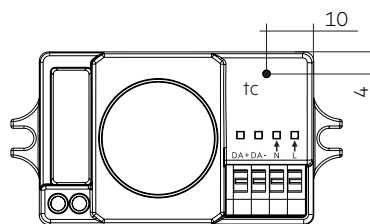

#### 4. Installation



- The sensor must protrude over the light sources.
- Disconnect the power supply before installation.
- Suitable for installation only in indoor luminaires (e.g. corridors and closed parking garage) without vibration.
- Opening angle of the sensor: must be at least 45 %.
- Motion detection: only possible through thin housing material (e.g. plastic or glass), do not use metal housing.
- Light sensor: must be able to detect reflected artificial light and reflected daylight.
- Reflected HF waves (e.g. of walls, floors, ceilings or furniture) from other transmitters affect motion detection.
- Avoid direct illumination of the light source on the sensor including housing.

#### 4.1 Wiring diagram

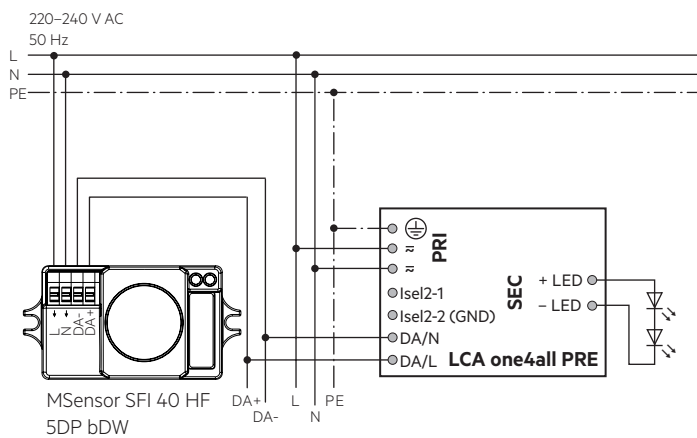

#### 4.2 Wiring type and cross section

For wiring use stranded wire with ferrules or solid wire from 0.5 to 1.5 mm<sup>2</sup>. Strip 8 mm of insulation from the cables to ensure perfect operation of the push-in terminals. Use one wire for each terminal connector only.

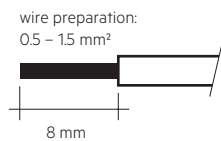

#### 4.3 Minimum spacing for further sensors

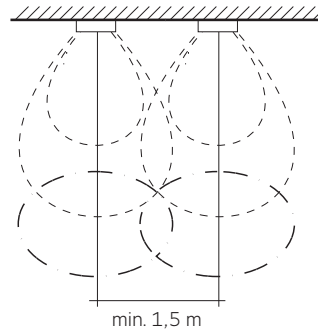

#### 4.4 Placement

The MSensor SFI 40 HF 5DP bDW has an integrated Bluetooth antenna for easy integration. In order to maximize the range in every direction consider the following design guidelines:

- The Bluetooth antenna is located at the end of the enclosure.
- When mounting the device on a metal plate (e.g. frame of a luminaire), it may efficiently block the radio frequency signal. In this case a cut-out underneath the Bluetooth antenna is may be needed for the RF signal to exit the structure. The cut-out area should be as large as possible.
- Place the device as far away as possible from any vertical metal structures.

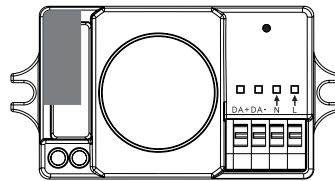

■ Bluetooth antenna position



The range of the communication signal is depending on the environment e.g. luminaire, construction of the building, furnitures or humans and needs to be tested and approved in the installation.



To ensure a good radio connection and function do not cover the MSensor SFI 40 HF 5DP bDW completely with metal!

## 5. Functions

### 5.1 Setting up

#### Setting the detection area

To avoid unnecessary switching on of the lighting system due to an excessively large detection area, this can be limited.

The detection area indicates the diameter within motion is detected.

Set this value with the 4remote BT app.

Sensitivity
100 % (default)
50 %
30 %
10 %

#### Setting the switch-off delay

To avoid unnecessary switching on and off of the lighting system it is possible to set a switch-off delay. The delay starts after the last motion in the detection area. With the detection of further motion during this delay it is retriggered. At the end of the delay the light will be switched off.

Set this value with the 4remote BT app.

#### Setting the daylight threshold value

To avoid unnecessary switching on of the lighting system when there is adequate illuminance, a threshold value can be set. The threshold value indicates up to which illuminance value detected movement cause the lighting system to switch on.

Set this value with the 4remote BT app.

Daylight sensor
Disable (default)
50 Lux
20 Lux
5 Lux
2 Lux

#### Daylight sensor with light guide

If the daylight threshold is disabled the Sensor can be used in closed loop applications.

It is important to ensure that the light sensor does not measure reflected light behind the diffuser (use a light guide) or that the sensor is placed outside the diffuser.

### 5.3 Start up behaviour

20 seconds after mains is connected, the sensor is ready and indicates this by flashing on the green LED.

5.4 Motion detection

Ceiling mounted:

Sensitivity				
h	100 %	50 %	30 %	10 %
	d			
0.5 m	-	-	-	-
1.0 m	-	-	-	-
1.5 m	-	-	-	-
2.0 m	5.0 m	3.0 m	1.5 m	1.0 m
2.5 m	6.0 m	3.0 m	1.5 m	1.0 m
3.0 m	6.0 m	3.0 m	1.5 m	1.0 m
3.5 m	6.0 m	3.0 m	1.5 m	-
4.0 m	5.0 m	2.5 m	1.0 m	-
4.5 m	4.5 m	2.0 m	-	-
5.0 m	4.0 m	2.0 m	-	-

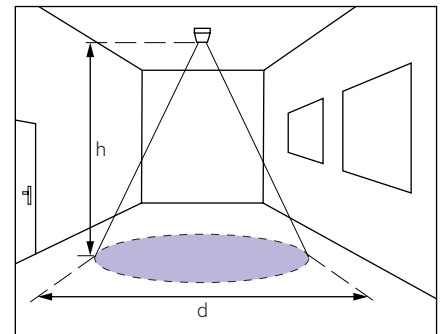
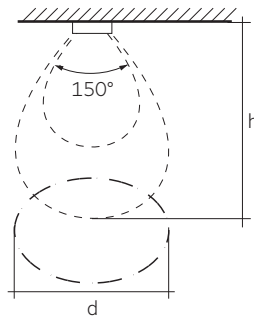

Wall mounted – passing by:

x	y	h	Sensitivity
5.0 m	5 m	1.8 m	100 %
1.5 m	4 m	1.8 m	50 %
1.0 m	3 m	1.8 m	30 %
0.5 m	2 m	1.8 m	10 %

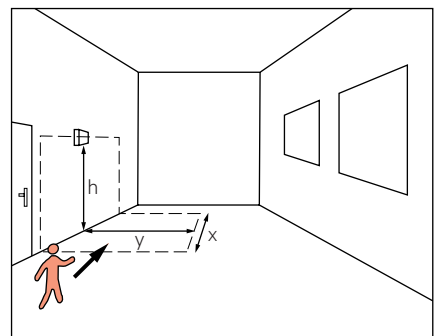
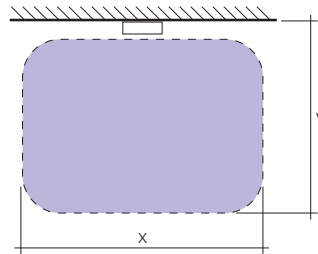

Wall mounted – moving towards:

x	y	h	Sensitivity
3 m	8 m	1.8 m	100 %
3 m	4 m	1.8 m	50 %
2.5 m	1.5 m	1.8 m	30 %
2 m	1 m	1.8 m	10 %

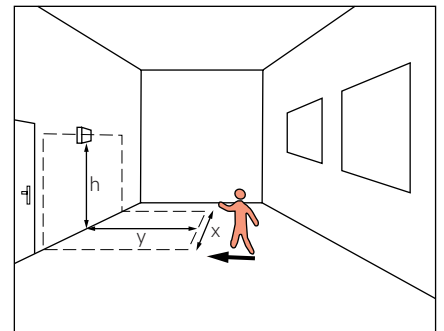
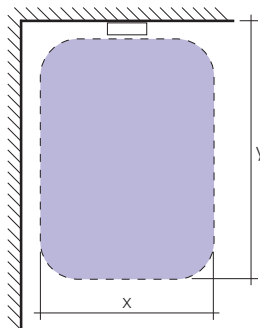

The table shows the diameter of the detection cone as a function of height at maximum detection area without considering objects in the room. Stationary objects (walls, tables, floor-standing luminaires, etc.) located in the direct view of the sensor change the characteristics of the detection area. The mentioned values are typical minimum values. Depending on the environment and application the detection area may increase.

5.5 Detection sensitivity

Optimized for detection of pedestrians with a speed of 0.5 – 1.5 m/s corresponds to 1.8 – 5.4 km/h.

Depending on the application and environmental conditions the maximum detectable speed of object may vary.

## 6. Miscellaneous

### 6.1 Disposal of equipment



Return old devices in accordance with the WEEE directive to suitable recycling facilities.

### 6.2 Conditions of use and storage

Environmental conditions: 5% up to max. 85%,  
not condensed

Storage temperature: -20 °C up to max. +70 °C

The devices have to be acclimatised to the specified temperature range (ta) before commissioning.

### 6.3 Additional information

The Bluetooth® word mark and logos are registered trademarks owned by the Bluetooth SIG, Inc. and any use of such marks by Zumtobel Group AG is under license.

Tridonic GmbH & Co. KG is a subsidiary of Zumtobel Group AG.

Additional technical information at [www.tridonic.com](http://www.tridonic.com) → Technical Data

Guarantee conditions at [www.tridonic.com](http://www.tridonic.com) → Services

Lifetime declarations are informative and represent no warranty claim.  
No warranty if device was opened.