

DALI MSensor G3 PIR 10DPI WH

DALI-2 multi-sensor



Product description

- _ Sensor developed to work with the latest DALI specification
- _ Monitoring of ambient light and occupancy detection
- _ Remote control interface allowing infrared remote control interaction
- _ Individual adjustment of the parameters with configuration software
- _ Power supply via DALI line
- _ Shutter for preventing occupancy detection in one direction included
- _ Small dimensions allowing easy and inconspicuous integration in luminaries
- _ Wide range of accessories allowing extended application range
- _ SSM version (28002879) = pre-configured bundle of SFI sensor (28002119) and ACU IP20 housing (28001874)
- _ 5 years guarantee (conditions at <https://www.tridonic.com/manufacture-guarantee-conditions>)

DALI MSensor G3 SFI 30 PIR 10DPI WH



Housing properties

- _ Casing: polycarbonate, white
- _ Type of protection up to IP66

Note

- _ Tridonic DALI MSensor G3 family sensors are developed according to DALI Standard EN 62386-101 Ed.2, also known as DALI-2. To be able to use the sensor in such installation, an application controller is necessary.
- _ List of approved application controller can be found on our WEB page in "Downloads" in document "Application_controllers_MSensor_G3.pdf".

DALI MSensor G3 SSM 30 10DPI WH

Website

<http://www.tridonic.com/28002119>



DALI MSensor G3 PIR 10DPI WH

DALI-2 multi-sensor

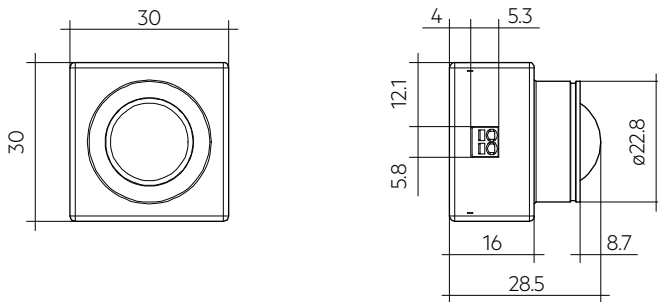

DALI MSensor G3 SFI 30 PIR 10DPI WH

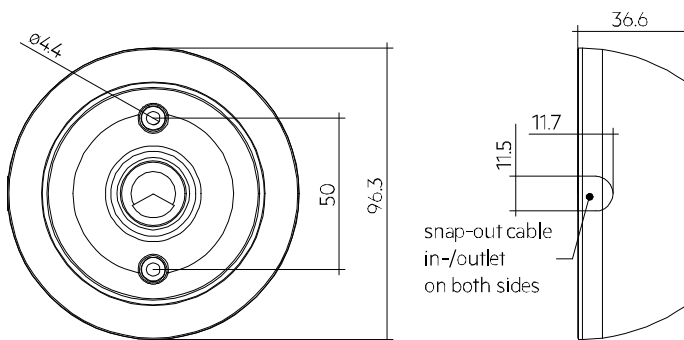

DALI MSensor G3 SSM 30 10DPI WH

Ordering data

Type	Article number	Suitable for	Dimensions L x W x H	Packaging, carton	Weight per pc.
MSensor G3 SFI 30 PIR 10DPI WH	28002119	Luminaire installation	30.0 x 30.0 x 28.5 mm	10 pc(s).	0.013 kg
MSensor G3 SSM 30 10DPI WH	28002879	Remote installation	96.3 x 96.3 x 36.6 mm	30 pc(s).	0.077 kg

Technical data

Sensor type	PIR sensor
Supply via	DALI cable
Supply voltage ^①	9.5 – 22.5 V
Current draw	6 mA from DALI
Current consumption (no LED)	≤ 8 mA
Current consumption (with LED)	≤ 9 mA
Supported operating modes	0 or 128 (default)
Mounting height	5 – 10 m
Mounting hole diameter	23 mm
Housing thickness of the luminaire	0.75 – 4 mm
Detection angle for PIR detection (tagential / radial)	72° / 44°
Detection angle for light measurement	30° – 40°
Detection range for light measurement ^②	0.5 – 2,000 lx
Min. temperature difference between ambient temperature and detected object	± 4 °C
Ambient temperature t_a	-20 ... +50 °C
tc point	60 °C
Storage temperature t_s	-25 ... +60 °C
Housing material body	PC polycarbonate
Housing material lens	PE polyethylene
Housing colour body	White (similar to RAL 9016)
Housing colour lens	White
Type of protection ^③	Up to IP66
Lifetime	up to 50,000 h
Guarantee (conditions at www.tridonic.com)	5 Year(s)

Approval marks**Standards**

EN 61347-2-11, EN 55015, EN 61000-3-2, EN 61000-3-3, EN 61547, EN 62386-101, EN 62386-103, EN 62386-301, EN 62386-303, EN 62386-304, EN 62386-332

① U_{in} acc. IEC 62386-101.

② The measured value at the sensor head corresponds to approx. 3 to 6,300 lux on the surface measured.

③ Depending on the installation type up to IP66 for more details see data sheet chapter 3.7.

Sensor mounting kit ACU 033 IP66 WH

Accessory



Product description

- _ Easy to mount circlip locking, compatible with industry standard circlip pliers (size 19 – 60 mm)
- _ Corrosion resistant circlip made from stainless steel
- _ Appealing plastic cover ring, allowing to mount the sensor in luminaires in an easy and visual attractive way
- _ Fulfills the impact energy requirements of freestanding luminaires of 0.5 J
- _ Includes 2 gaskets offering flexible installation in luminaires
- _ Plastic cover passed glow wire test with 750 °C in according to EN 61347-1
- _ In combination with the DALI MSensor G3 SFI 30 PIR 4DPI WDA WH, a maximum of IP54 is possible
- _ In combination with the basicDIM ILD G2 4DPI WDA, a maximum of IP54 is possible

Website

<http://www.tridonic.com/28004207>



Ordering data

Type	Article number	Packaging, carton	Weight per pc.
Sensor mounting kit ACU 033 IP66 WH	28004207	20 pc(s).	0.006 kg

Sensor mounting kit ACU 030 IP66 WH

Accessory



Product description

- _ Mounting ring allowing to mount the sensor into a luminaire in easy and visual attractive way
- _ Including three different gaskets 3, 5 and 8 mm
- _ For more details see data sheet chapter 3.5 (mounting ring) and 3.6 (gasket)
- _ Mounting ring passed glow wire test with 750 °C according to EN 61347-1
- _ In combination with the DALI MSensor G3 SFI 30 PIR 4DPI WDA WH, a maximum of IP54 is possible

Website

<http://www.tridonic.com/28002459>



Ordering data

Type	Article number	Packaging, carton	Weight per pc.
Sensor mounting kit ACU 030 IP66 WH	28002459	20 pc(s).	0.006 kg

REMOTECONTROL IR6

Accessory



Product description

- _ Optional infra-red remote control
- _ Switching on and off (On/Off button)
- _ Dimming (Up/Down button)
- _ Activation of automatic lighting control (Automatic button)
- _ Setting the threshold control point (Set button)
- _ IR range up to 20 m

Website

<http://www.tridonic.com/28000647>



Ordering data

Type	Article number	Dimensions L x W x H	Packaging, carton	Weight per pc.
REMOTECONTROL IR6	28000647	86.5 x 40.5 x 7.2 mm	500 pc(s).	0.019 kg

Sensor housing ACU 031 IP20 WH

Accessory



Product description

- _ Mounting frame for wired DALI MSensor G3 SFI 30 PIR 10DPI WH sensors allowing direct mounting to the ceiling
- _ Easy „click in“ installation of the sensor
- _ IP20
- _ Casing: polycarbonate, white
- _ UV stabilized plastic
- _ DALI MSensor G3 SFI 30 PIR 10DPI WH is powered via DALI circuit
- _ Mounting kit with screws and decorative plugs
- _ 0.5 mm² wiring for the sensor
- _ Two 3 x 1.5 mm² clamps with cable management (2 entry points on opposite sides)
- _ Including gasket for ideal IP protection
- _ Casing passed glow wire test with 850 °C according to EN 61347-1

Website

<http://www.tridonic.com/28001874>



DALI MSensor G3 SSM 30 10DPI WH

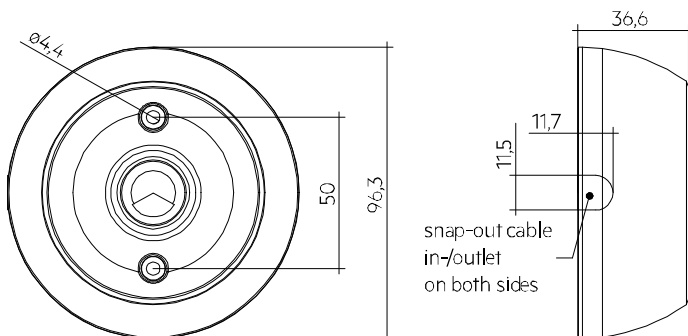

Ordering data

Type	Article number	Packaging, carton	Weight per pc.
Sensor housing ACU 031 IP20 WH	28001874	81 pc(s).	0.054 kg

Sensor housing ACU 032 IP66 WH

Accessory

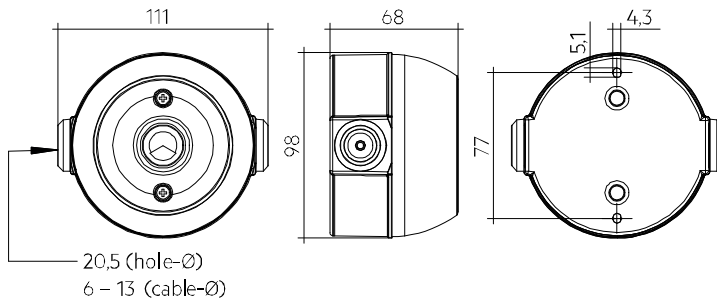

Product description

- _ Mounting frame for wired DALI MSensor G3 SFI 30 PIR 10DPI WH sensors allowing direct mounting to the ceiling
- _ Easy „click in“ installation of the sensor
- _ Housing provides IP 66, but in combination with the DALI MSensor G3 SFI 30 PIR 4DPI WDA WH a maximum of IP54 is possible
- _ Casing: polycarbonate, white
- _ UV stabilized plastic
- _ DALI MSensor G3 SFI 30 PIR 10DPI WH is powered via DALI circuit
- _ Optional shutter for reduction of occupancy detection area allowing to decrease the occupancy detection area from 360° to 240°
- _ Mounting kit with screws and decorative plugs
- _ Including gasket for ideal IP protection
- _ Casing passed glow wire test with 850 °C according to EN 61347-1

Website

<http://www.tridonic.com/28001873>



Ordering data

Type	Article number	Packaging, carton	Weight per pc.
Sensor housing ACU 032 IP66 WH	28001873	26 pc(s).	0.105 kg

1. Standards

EN/IEC 61347-2-11:2001
 EN 55015:2013
 EN 61000-3-2:2014 Part 3-2
 EN 61000-3-3:2013 Part 3-3
 EN 61547:2009
 EN 62386-101 Ed.2
 EN 62386-103 Ed.1
 EN 62386-301
 EN 62386-303
 EN 62386-304
 EN 62386-351

1.1 DALI note



Sensor is only applicable for DALI-2 installations according to EN 62386-101 Ed.2.

List of approved application controller can be found on our WEB page „[Application_controllers_MSensor_G3.pdf](#)“

Following table shows the instances and which values they provide.

DALI instances	
Instance number	Explanation
0	Occupancy sensor DALI Part 303
1	Light sensor DALI Part 304
2 – 19 ^①	Push button DALI Part 301

^① Sensors produced before 25.07.23 do provide 13 instances and do not support Tridonic IR6+ remote control.

1.2 D4i note

D4i luminaire-mounted control devices (part 351) = Type B

1.3 Glow wire test

according to EN 61347-2-11 passed for temperatures up to 750°C.

2. Common

DALI MSensor G3 SFI 30 PIR 10DPI WH is one of the new generation of Tridonic sensors.

With this Sensor, the customer gets a small sized sensor for medium height applications and a protection against environmental influence up to IP66.

This sensor provides measurement of ambient light, occupancy detection via PIR sensor and IR remote control input as well as a LED output for signalisation.

DALI MSensor G3 SFI 30 PIR 10DPI WH is created for following main applications:

Medium height buildings such as

- Factory buildings
- Storage buildings and warehouses
- Corridors, passages und Garages
- Outdoor applications

3. Installation

- The DALI MSensor must not be connected to the mains. It is supplied directly via the DALI power supply.
- DALI is not SELV.
The installation instructions for mains voltage therefore apply.
- Please ensure that the detection range of the sensor lies in the lighting area of the controlled luminaires.
- Please ensure that the detection ranges of the sensors do not overlap. This may have influence to the lighting control.
- When installed at a height other than the recommended installation height, the sensor might show different characteristics.
When mounted at a higher level, its sensitivity is reduced.
If mounted at a lower level, its range is reduced.
- Heaters, fans, printers and copiers located in the detection zone may cause incorrect occupancy detection.
- Avoid direct illumination of the light source on the sensor including housing.

3.1 Wiring

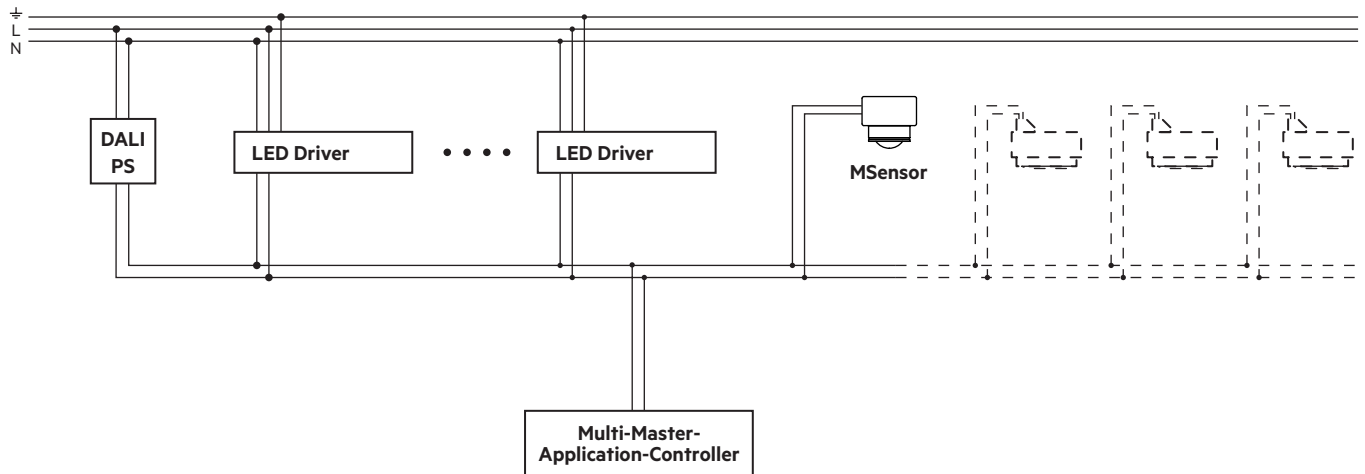

3.2 Wiring type and cross section

For wiring use stranded wire with ferrules from 0.2 to 0.5 mm² or solid wire from 0.14 to 0.5 mm².

0.14 – 0.5 mm² solid or
0.2 – 0.5 mm² stranded wire

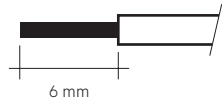

3.3 Mounting variants luminaire installation sensor:

3.3.1 Installation in luminaire

To ensure the right IP protection please read chapter 3.6 Gasket.

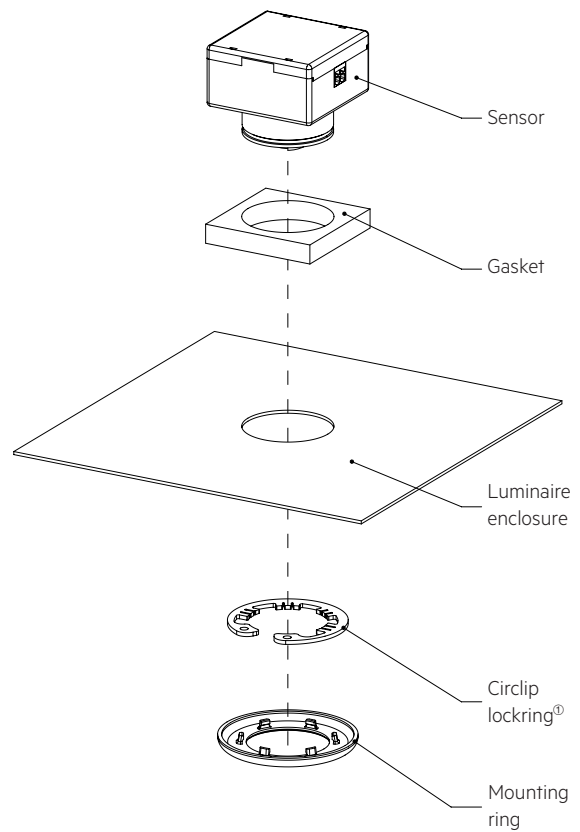

[®] Not included in kit ACU 030.

3.3.2 Installation in Sensor housing ACU 032 IP66 WH

To ensure the right IP protection please read chapter 3.6 Gasket.

Step 1: Cover placed on base plate

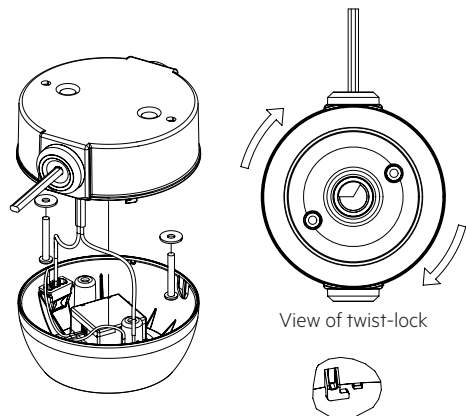

Step 2: Cover locked

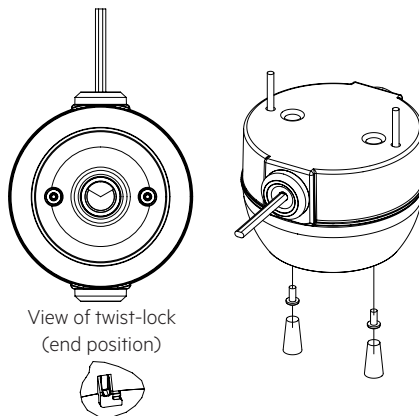

Mount base plate. Feed cable (cable diameter: 6 – 13 mm) of the lateral grommets into the installation terminals.

After the cover is loosely mounted on the base plate, insert and tighten the 2 screws. In the last step insert in the sealing plugs.

3.3.3 Installation in Sensor housing ACU 031 IP20 WH

To ensure the right IP protection please read chapter 3.6 Gasket.

Exploded view

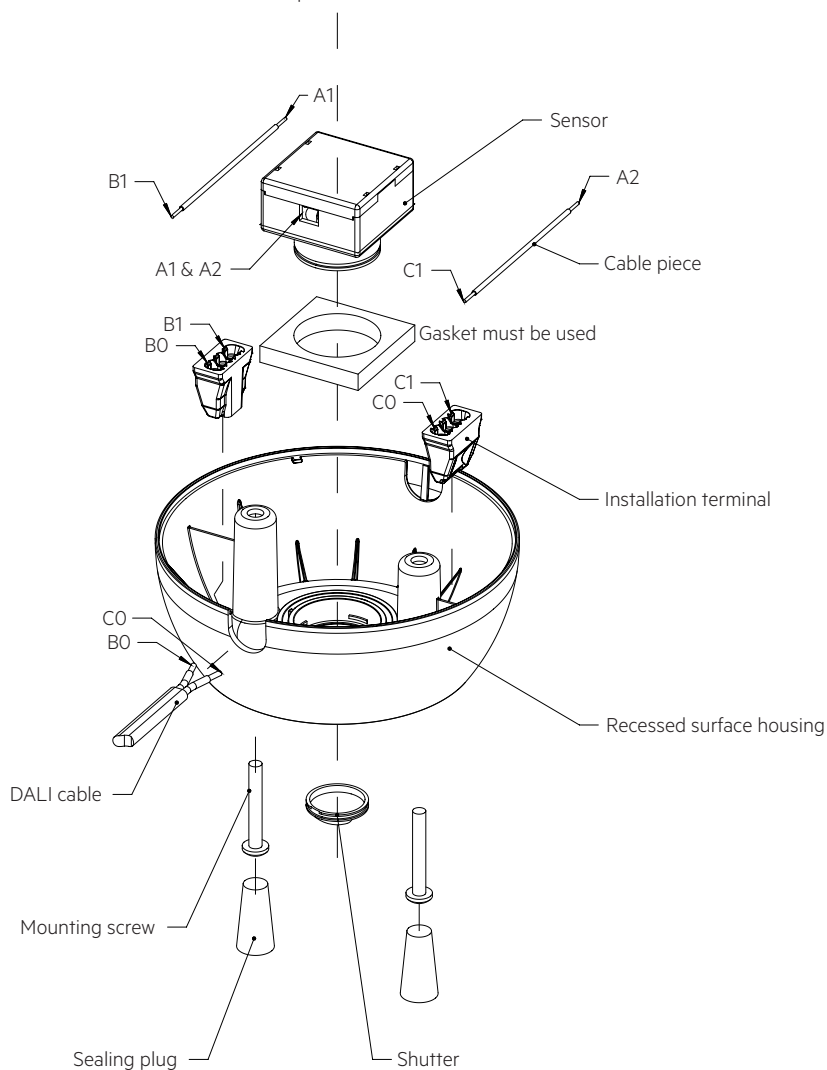

Top view

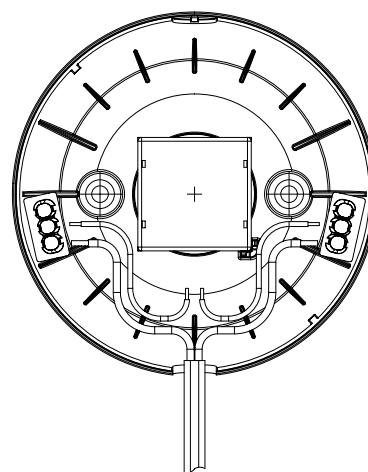

3.4 Detection area covers

Included in each Sensor 10DPI 23f there are two detection area covers. Each of these cover can be attached to the front of the sensor. The 120° cover offers the possibility to reduce the detection area of PIR Sensor by 120° or 1/3 of its detection area. There is no influence of detection area of light measurement or IR receiver by this cover. 0° cover is made only for aesthetical reasons to give the sensor a flush surface. It is not needed for proper operation of the sensor.

Type of material: PC polycarbonate
 Colour: transparent
 Surface finish: polished

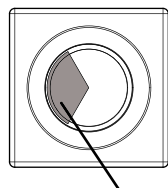
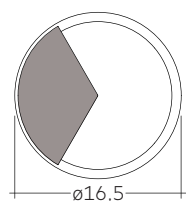
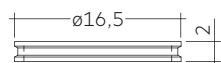

Attach the detection area cover to the sensor by inserting it into the corresponding groove at the front of the sensor.

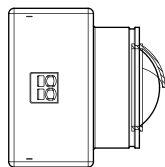

Area which is masked by the shutter:

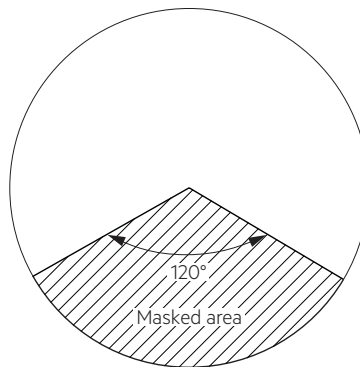
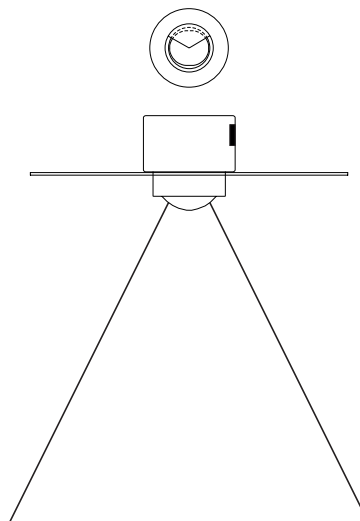

3.5 Mounting ring

Included in each Sensor mounting kit ACU 030 IP66 WH and kit ACU 033 IP66 WH is a mounting ring. This Ring allows to mount the sensor into a luminaire in an easy and visual attractive way.

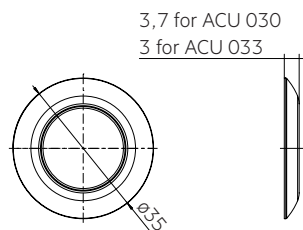

3.6 Gasket

To fulfill ingress protection different gaskets are included in the Mounting Kit. The gaskets are necessary to ensure ingress protection as well as proper mounting of the sensor in luminaire.

Sensor can be inserted into luminaires with a cover size from 0.75 up to 4.0 mm.

According to the size of luminaire cover in certain application, one of the gaskets must be used and mounted between the front of the sensor and the luminaire housing. It is not allowed to use a combination of e.g. two gaskets, because this will not provide the right amount of sealing and you may run in to a risk to not reach the IP66 requirements.

 Use maximum possible size for your application to ensure a proper fit and protection.

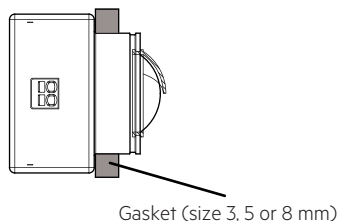

Sensor mounting kit ACU 030 IP66 WH

Distance between Sensor and luminaire	Final size of gasket after assembly	Use gasket
2.0 – 2.4 mm	2.0 – 2.4 mm	3 mm
2.5 – 4.0 mm	2.5 – 4.0 mm	5 mm
4.0 – 5.9 mm	4.0 – 5.9 mm	8 mm

Sensor mounting kit ACU 033 IP66 WH

Distance between Sensor and luminaire	Final size of gasket after assembly	Use gasket
2.7 – 4.0 mm	2.7 – 4.0 mm	5 mm
4.0 – 5.9 mm	4.0 – 5.9 mm	8 mm

3.7 Ingress protection

This device contains IP-protection to use it also in applications with the need of protection against dust and water ingress. IP66 protection applies to the front of the sensor whereas the back of the sensor is IP20 rated.

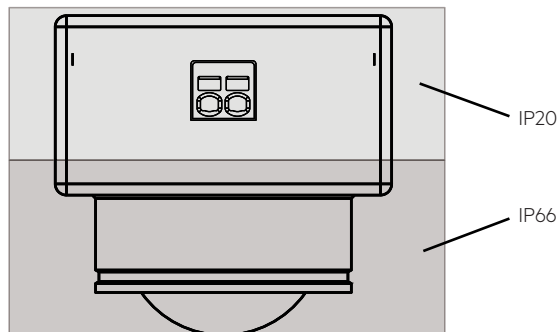

3.8 Mounting in class II luminaire

The Sensor provides basic insulation as required by IEC 62386-101 and defined in IEC 61347-1.

If the sensor is built in to a class II luminaire which has to provide double or reinforced insulation it has to be considered that the Sensor is not a class II device. Still the Sensor can be used for such projects as the most part of the sensor is tested to fulfil the class II requirements for double or reinforced insulation. Basic insulation is illustrated in the graphic below and covers an area 2,5 mm around the terminal. The rest of the sensor fulfils class II requirements.

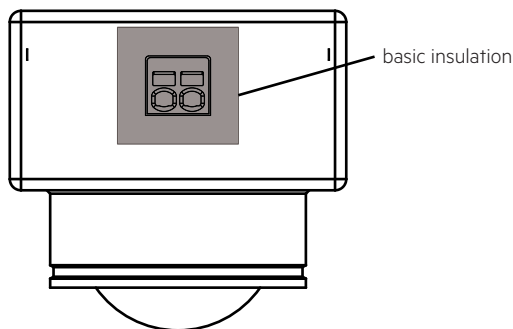

4. Sensor function

4.1 Occupancy / motion detection

For occupancy detection PIR technology is used. PIR Lens is made to detect moving people in working areas such as warehouses, storage buildings and similar working areas with the following performance criteria:

- Ceiling height from 5 up to 10 m
- Movement of human body (increment ≥ 1.5 m), no slight motion (no sitting person)
- Movement ≥ 1.0 m/s for mounting heights up to 7.5 m
- Movement ≥ 1.5 m/s for mounting heights up to 10.0 m

4.2 Detection area

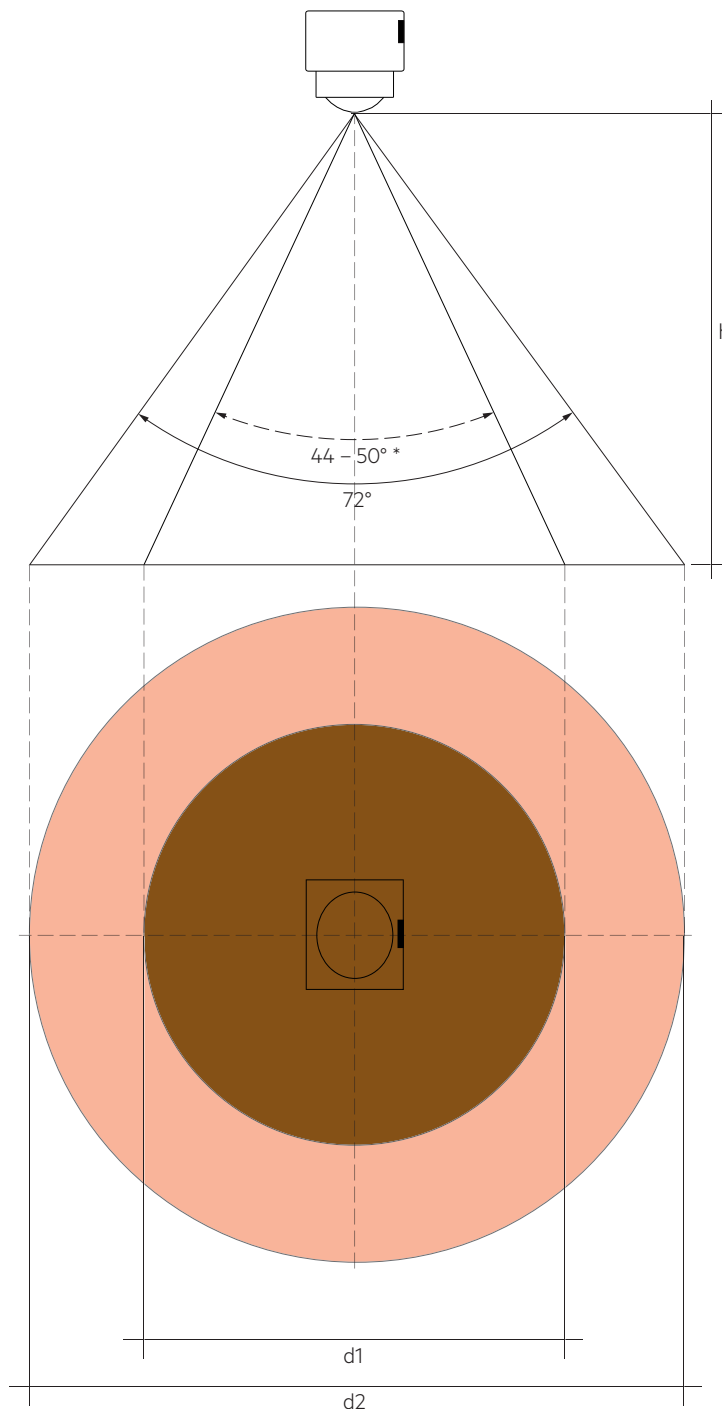

Reaction time of the sensor (time between occupancy detected and event information send to DALI Bus) is ≤ 25 ms.

The reaction time of the system can be extended by factors such as the amount of data on the bus, the number of connected devices or the control device used (Application Controller).

The point at which the light responds must therefore not be equated with the outer detection range.

h = Height	d1 = Radial	Radial detection angle	d2 = Tangential (72°)
5 m	4.6 m	50°	7.0 m
6 m	5.6 m	50°	8.4 m
7 m	6.6 m	50°	9.8 m
8 m	7.4 m	50°	11.2 m
9 m	7.2 m	44°	12.6 m
10 m	8.0 m	44°	14.0 m

Schematic illustration of radial / tangential movements:

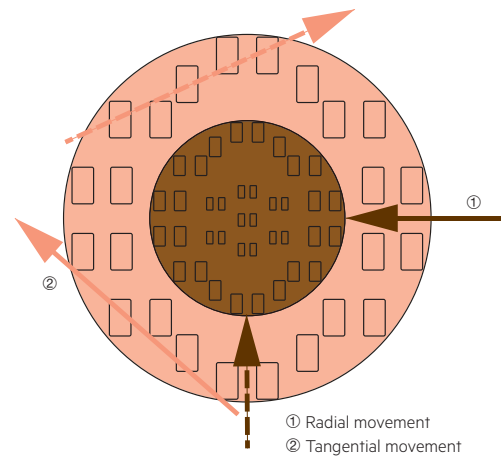

* The detection angle for the radial movement varies with the different mounting height between 44 and 50°.

Detection example at 5 m mounting height:

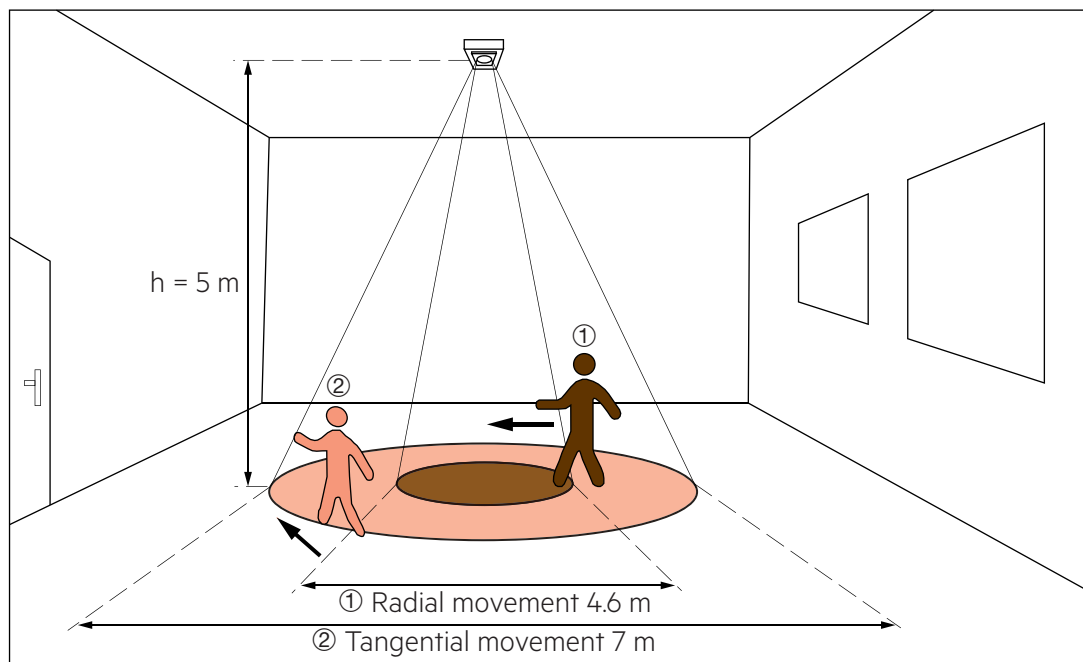

4.3 Light measurement

The light measurement has a cone-shaped detection area with a half angle of approximately 20° in x-direction and 15° in y-direction.

The measurement range is between 0.5 and 2000 lx. Measured at the sensor head.

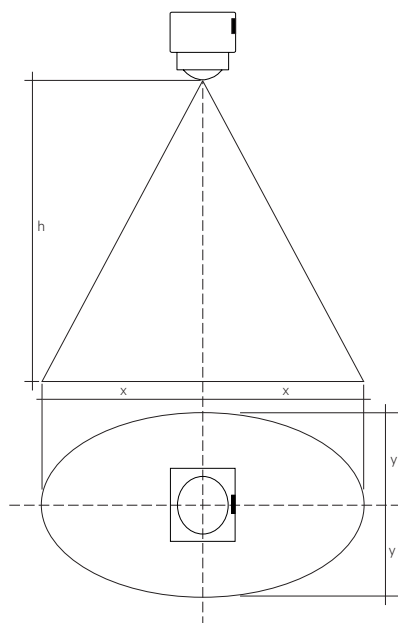

h	dx	dy
5.0 m	3.6 m	2.7 m
7.5 m	5.5 m	4.0 m
10.0 m	7.2 m	5.4 m



To be able to measure values < 5 lx in an accurate way it is needed to change integration time of light sensor to 800 ms. Integration time of light sensor is set to 100 ms by default. For values > 5 lx there is no difference in between these measurements.

4.4 Status LED's

There is a LED built in to indicate different status information to the user.

Event	Blinking sequence	LED Color
DALI command „identify device“	500 ms on / 500 ms off for 10 s	Red
Motion detection ^①	Default deactivated but can be activated by the application controller. If active, 1000 ms on every time Motion is detected.	Red
IR-Signal received ^①	Double blinking (150 ms on / 150 ms off) on every received IR-command.	Red

Light measurement priority

① By default, these blinking patterns are interrupted by the light measurement, because the light measurement has a higher priority. This behavior can be changed via the application controller, i.e. it can be configured that the blinking patterns are carried out, regardless of an ongoing light measurement. Consequently, the accuracy of the light measurement will become worse, because the brightness of the LED distorts the measurement.

4.3.1 Light value format

The default operating mode is 128.

In this mode the user is able to choose from fixed point and floating point values for the light measurement. The default setting are floating point values.

In addition to operation mode 128 also operating mode 0 is implemented. In operating mode 0 the fixed point values are supported for the light measurement values.

Resolution for fixed point and floating point = 1/64 Lux

5. Configuration

Optimized for the operation in conjunction with the Tridonic application controller sceneCOM S.

For commissioning and configuration the App „sCS commissioning“ (sceneCOM S) is provided by Tridonic. App can be installed on iOS and Android devices. Compatible with Android 6.0 / iOS 10 or later, devices with a min. screen size of 20 cm diagonal and a min. resolution of 1024 x 768 pixels.

Android:



iOS:



6. Miscellaneous

6.1 Disposal of equipment



Return old devices in accordance with the WEEE directive to suitable recycling facilities.

6.2 Additional information

Additional technical information at www.tridonic.com → Technical Data

Guarantee conditions at www.tridonic.com → Services

Lifetime declarations are informative and represent no warranty claim. No warranty if device was opened.